

# CARBURETOR PARTS

Homelite Chain Saw

Assembly Number  
A-59427-A

Service Replacement  
for A-58360, A-58360-A

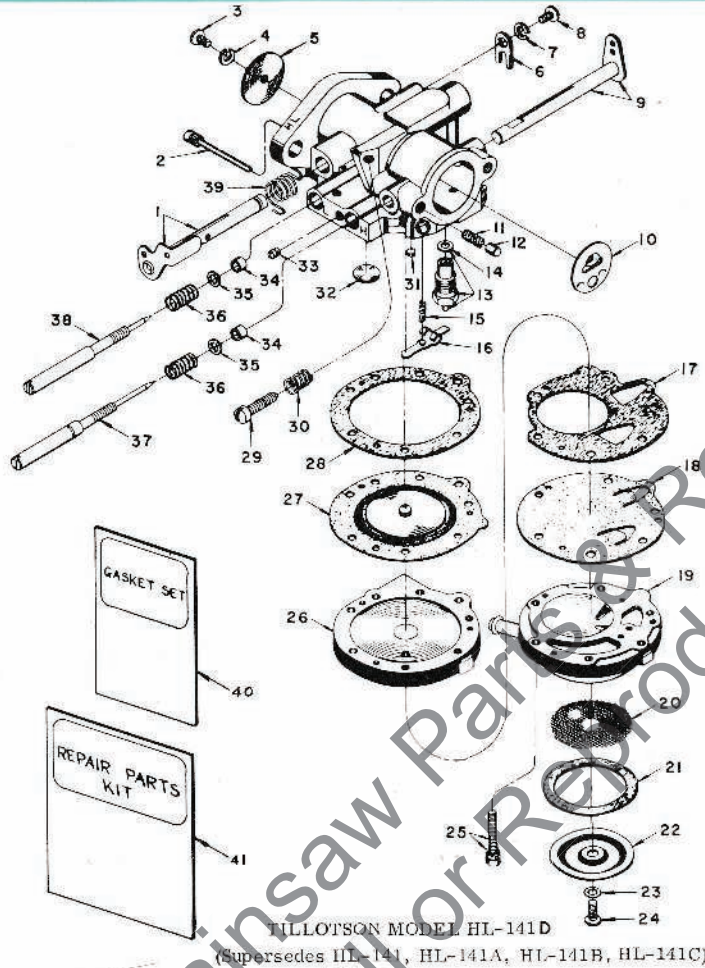

Index No.	Part No.	Description	No. Required
1	A-58531	THROTTLE SHAFT & LEVER.....	1
2	*A-55762	PIN - fulcrum.....	1
3	*80591	SCREW - rd. hd., 4 - 40 x 1/4".....	1
4	*83008	WASHER - lock, #4.....	1
5	75532	SHUTTER - throttle.....	1
6	73086	CLIP - throttle shaft.....	1
7	83000	WASHER - lock, #8.....	1
8	73088	SCREW - flat hd., 8 - 32 x 5/16".....	1
9	A-58532	CHOKE SHAFT & LEVER.....	1
10	77427	SHUTTER - choke.....	1
11	73264	SPRING - choke friction.....	1
12	71494	PLUNGER.....	1
13	*A-58524	INLET NEEDLE & SEAT.....	1
14	55344	Includes GASKET.....	1
15	*55759	SPRING - tension.....	1
16	*55747	LEVER - inlet control.....	1
17	58529	GASKET - fuel pump.....	1
18	*58193	DIAPHRAGM - fuel pump.....	1
19	59265	† BODY - fuel pump (HL-141C, -141D)	1
	58530	† BODY - (HL-141, -141A, -141B)	1
20	*58527	SCREEN - strainer.....	1

Index No.	Part No.	Description	No. Required
21	55751	GASKET - strainer.....	1
22	58526	COVER - strainer.....	1
23	28098	GASKET - cover screw.....	1
24	*58525	SCREW - cover retaining.....	1
25	55316	SCREW - fil. hd., 6-32 x 13/16"....	6
		w/lock washer	
26	A-58533	COVER - diaphragm.....	1
27	*57829	DIAPHRAGM - main.....	1
28	57824	GASKET - diaphragm cover.....	1
29	*71509	†† SCREW - idle stop, see Note.....	1
30	*28064	†† SPRING - idle stop screw, see Note	1
31	*55763	PLUG - cup.....	1
32	*30818	PLUG - Welch.....	1
33	73067	SCREW PLUG - drain.....	1
34	75733	PACKING - adjusting needle.....	2
35	75735	WASHER - adjusting needle.....	2
36	*73075	SPRING - adjusting needle.....	2
37	*58536	NEEDLE - main adjusting.....	1
38	*58650	NEEDLE - idle adjusting.....	1
39	59268	SPRING - throttle return (HL-141C, -D)	1
40	*58534	GASKET SET.....	1
41	58681	REPAIR PARTS KIT.....	1

\*Included in REPAIR PARTS KIT

† Fuel pump body not interchangeable, check carburetor model.

†† Service replacement carburetor #A-59427-A supplied with idle stop screw (#29) and spring (#30) which must be removed when an external idle adjustment is used. When old fuel line fitting is on choke lever side adapt fuel line to new outlet location by cutting approximately 2 1/2" from end so that line is not restricted.

# HOMELITE