

# HOMELITE

## CHAIN SAW



**XL-660**  
**AUTOMATIC**

**PARTS LIST**

# HOMELITE **XL-660** AUTOMATIC CHAIN SAW

FIGURE 1

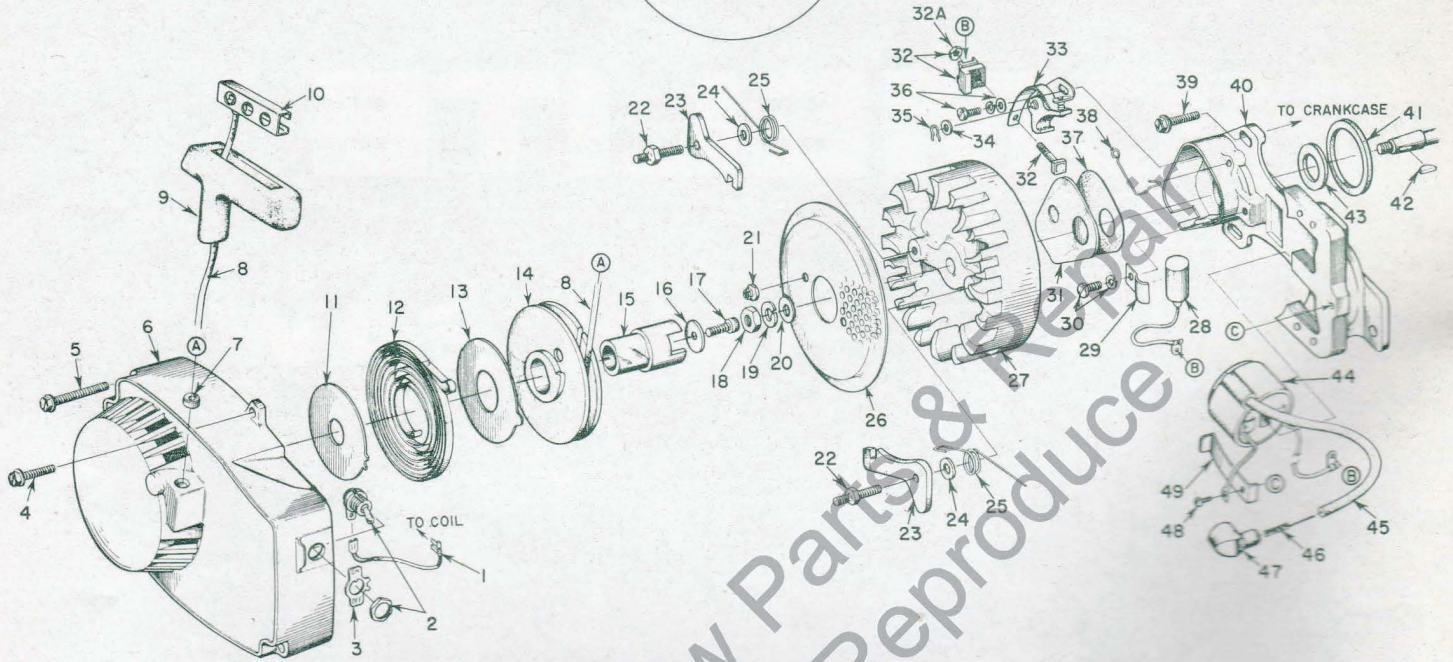
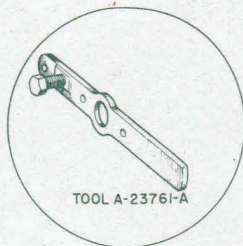
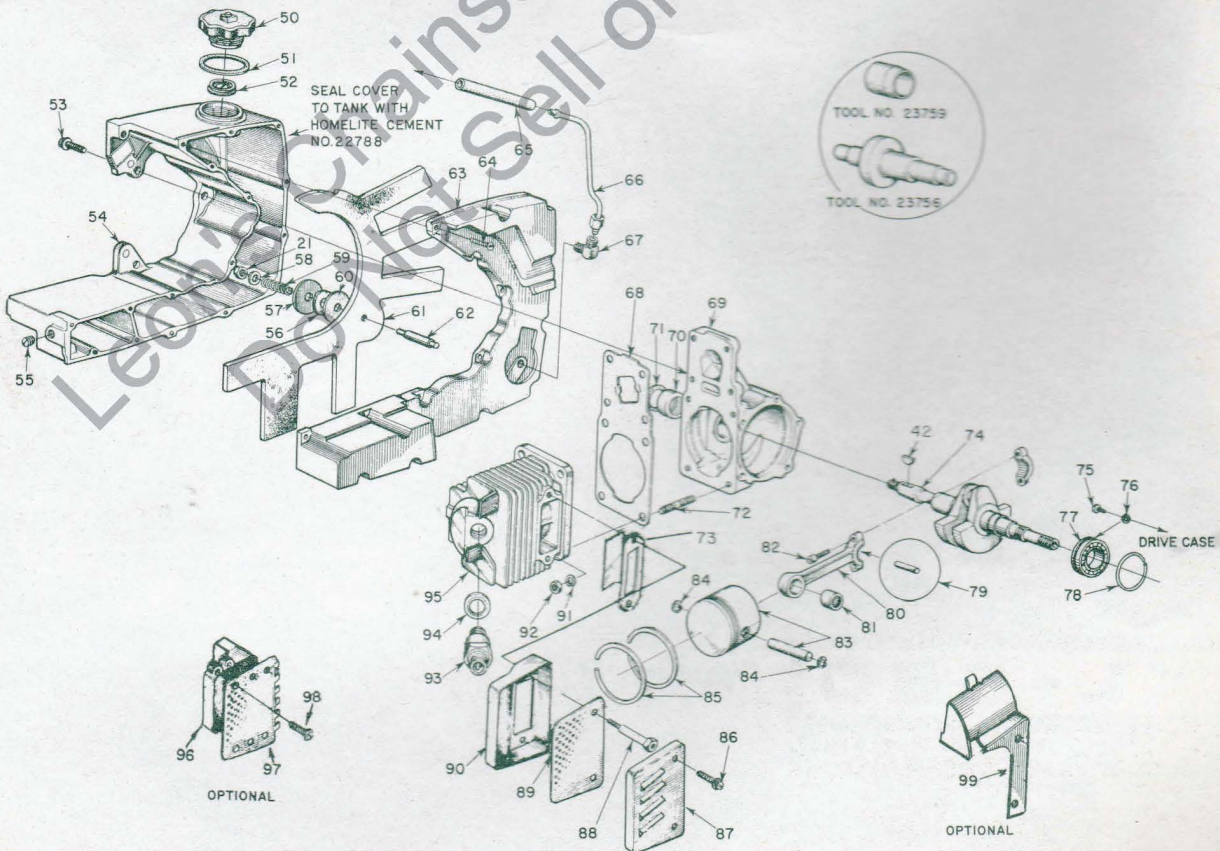

FIGURE 2



# HOMELITE XL-680 AUTOMATIC CHAIN SAW

No.	Description	Part No.	Qty.	No.	Description	Part No.	Qty.
1	LEAD - ground w/term.	A-59031	1	47	BOOT - spark plug	58918	1
2	SWITCH - w/nut	A-57650-3	1	48	SCREW - coil clip "W"	58872	1
3	PLATE - "ON-OFF"	72085-A	1		"P"	55977	1
4	SCREW - hex, 12-24 x 5/8	80676	1	49	CLIP - coil retaining "W"	58873	1
5	SCREW - hex, 12-24 x 1 11/16	58963	3		"P"	59863	1
6	FAN HOUSING	A-59824	1	50	CAP - fuel filler	A-59956	1
7	Includes: BUSHING - rope	59313	1	51	Includes: GASKET	58957	1
8	ROPE - starter	58806	1	52	VALVE	58685	1
9	GRIP - rope	58915	1	53	SCREW - hex, 12-24 x 3/4	80867	3
10	INSERT	58847	1	54	TANK - fuel	58732	1
11	SHIELD - spring (inner)	59638-A	1	55	PLUG - pipe, 1/16-27	59571	1
12	SPRING - recoil	58764	1	56	GASKET	58865	1
13	SHIELD - spring (outer)	59639-A	1	57	WASHER - wick	58866	1
14	PULLEY - starter	58759-A	1	58	WASHER - flat, #10	84003-1	1
15	CUP - starter	58760	1	59	SPRING - compression	58867	1
16	WASHER - retaining	58763	1	60	WASHER - felt	59457	1
17	SCREW - socket, 10-32 x 1/2	80492	1	61	WICK - fuel pick-up	58862	1
18	NUT - hex, 5/16-24	81117	1	62	STUD - wick	58519	1
19	WASHER - lock, 5/16	83002	1	63	COVER - tank	59693	1
20	WASHER - flat, 5/16	84056	1	64	SCREW - rd., #6 x 1/2	80513	16
21	NUT - lock, 10-32	81109	3	65	LINE - fuel, flexible	59828	1
22	STUD - shoulder	58757-A	2	66	LINE - fuel, formed	A-59814	1
23	FINGER - starter	58756	2	67	ELBOW - fuel line	58995	1
24	WASHER	58851	2	68	GASKET	59771	1
25	SPRING - starter finger	58758	2	69	CRANKCASE	A-59801	1
26	SCREEN - starter	58765	1	70	Includes: BEARING	58956	1
27	ROTOR - magneto "W"	58809	1	71	SEAL	58688-A	1
	"P"	59857	1	72	STUD	55871	4
28	CONDENSER "W"	63250	1	73	DEFLECTOR - air	63033	1
	w/clamp "P"	59862	1	74	CRANKSHAFT	59731	1
29	CLAMP - condenser "W"	59622	1	75	SCREW - bearing retaining	59704	2
30	SCREW GROUP - condenser "W"	30261	1	76	WASHER - lock	59705	2
	"P"	57750	1	77	BEARING - ball	58190-S	1
31	COVER - breaker box "W"	58811	1	78	RING - retaining	59319-A	1
	"P"	59864	1	79	ROLLERS - set (28)	A-58864	1
32	TERMINAL BLOCK GROUP "W"	A-58984	1	80	CONNECTING ROD	A-58769	1
32A	NUT (only) - terminal "P"	55982	1	81	Includes: BEARING	58724	1
33	POINT SET - w/felt "W"	A-58914	1	82	SCREW - socket, 8-36 x 1/2	80889	2
34	Includes: WASHER - point "W"	28028	1	83	PISTON & PIN - 2"	A-63095	1
35	CLIP - post "W"	28008	1	84	Includes: RING - retaining	75120	2
33	POINT SET w/felt & term. block "P"	A-59861	1	85	PISTON RING	55038	2
36	SCREW GROUP - points "W"	76421	1	86	SCREW - hex, 10-32 x 9/16	80825	2
	"P"	57749	1	87	CAP - muffler	A-63246	1
37	GASKET - cover "W"	58810	1	88	STUD	59891-A	2
	"P"	59865	1	89	BAFFLE	63064	1
38	SPRING - cover (clip) "W"	76413	1	90	BODY - muffler	A-59895	1
	"P"	59866	1	91	WASHER - lock, 1/4	83009	4
39	SCREW - hex, 12-24 x 9/16	80899	3	92	NUT - 1/4-28	81065-2	4
40	PLATE & CORE "W"	58875-A	1	93	SPARK PLUG	58917-S	1
41	GASKET	59538	1		optional - platinum	59558-S	1
42	KEY - rotor	75078	1	94	Includes: GASKET	25038	1
43	SEAL - felt	59760	1	95	CYLINDER - 2" bore	59458-A	1
44	COIL "W"	58874	1	96	NOISE SUPPRESSOR	A-63080	1
	"P"	59860	1	97	Includes: BAFFLE	A-63081	1
45	LEAD - hi-tension	58966	1	98	SCREW (8-32-3/8)	80939	4
46	SPRING - contact	58919	1	99	EXCHANGER - heat	A-63321	1

NOTE: Ignition Type - "W" indicates Wico, "P" indicates Phelon  
DO NOT INTERCHANGE PARTS

# HOMELITE XL-660 AUTOMATIC CHAIN SAW

No.	Description	Part No.	Qty.	No.	Description	Part No.	Qty.
1	GASKET - spacer	59274	2	38	PLUG	59798	1
2	SPACER	59718	1	39	GASKET	59799	1
3	SEAT - reed valve	59677	1	40	SPRING - plunger	59293	1
4	VALVE - reed	59678-A	4	41	PLUNGER - oil pump	A-57834-10	1
5	SPRING - valve	59679	4	42	Includes: "O" RING - plunger shaft	59074	1
6	SCREW - pan, 4-40 x 18	80918	8	43	"O" RING - plunger	74388	1
7	LINE - fuel (flexible)	58958	1	44	TUBE - oil line	59325	1
8	GASKET - carburetor	59722	1	45	"O" RING	59765	2
9	CARBURETOR - See NOTE	A-58767-B	1	46	LINE - oil	59674	1
10	HOUSING & HANDLE	A-59931	1	47	FILTER - oil	A-58828	1
11	Includes: GASKET	58884	1	48	SCREW - rd. #6 x 1/2	80513	9
	(not shown) COTTER PIN	86301	1	49	COVER - oil reservoir	59649	1
	(not shown) FELT - pin	63290	1	50	GASKET - cover	59710	1
12	COTTER PIN	86324	1	51	"O" RING	58785	1
13	PLATE - instruction	59221	1	52	LINE - oil (discharge)	A-59806	1
14	COVER - air filter	58773	1	53	CAP - filler	A-56580	1
15	NUT - cover	A-58882	1	54	Includes: GASKET	56607	1
16	RING - retaining	58319-A	1	55	DRIVECASE	A-59930	1
17	FILTER ELEMENT	58774-1	1	56	Includes: STUD - guide bar	59674-A	2
18	GASKET - mounting stud	58392-1	1	57	INSERT - threaded	59896	2
19	BRACKET - mounting	A-59822	1	58	SEAL	58308	1
20	ROD - choke	A-59826	1	59	COTTER PIN	86301	1
21	ROD - throttle	59763	1	60	SCREW - pin, 1/4-20 x 2	63225	1
22	SCREW - hex, 12-24 x 7/8	80891	5	61	PIN - bar adjusting	58783	1
23	SCREW - idle, See NOTE	59916	1	62	NUT - lock, 1/4-20	81108	1
24	BOOT - throttle rod	58348	1	63	SCREW - hex, 12-24 x 9/16	80899	4
25	WASHER - lock, #10	83046	2	64	SCREW - hex, 12-24 x 1	80864	1
26	SCREW - hex, 10-32 x 2 11/16	80921	2	65	SCREW - cam	59737	1
27	PIN - throttle lock	58924	1	66	GASKET	59736	1
28	SPRING - lock	58405	1	67	"O" RING	90872	2
29	COVER - handle	A-59213	1	68	SEAL - felt	59926	1
	Includes: BUSHING - pin	59064	1	69	GEAR - worm	59675	1
30	SCREW - pan, 8-32 x 1/2	80560	2	70	SCREW - hex, 6-32 x 3/4	80950	3
31	RING - retaining	58409	1	71	HOUSING - oil pump	A-59810	1
32	THROTTLE - trigger	58859	1	72	PLUNGER & GEAR	59689	1
33	GROMMET	58362	1	73	BEARING - flanged	59719	1
34	BUTTON	57289-1	1	74	SCREW - pan, 4-40 x 1/4	80919	2
35	VALVE - check "IN"	A-59818	1	75	FILTER - oil w/connector	A-59804	1
36	VALVE - check "OUT", 90°	A-59011	1	76	LINE - oil (intake)	A-59819	1
37	GROMMET	59770	1	77	Includes: GROMMET	59794	1

NOTE: Service replacement carburetor #A-58767-B supplied with idle stop screw and spring (used in units with internal adjustment); remove these parts, use external adjustment screw (Index #23).

Refer to Carburetor Parts List #23766-B.  
Use Repair Parts Kit #58972, Gasket Set #58971.

### SPECIAL TOOLS (available on order)

Part No.	Description	Part No.	Description
22808	COMBINATION WRENCH	23800	TOOL-seal assembly (crank and drivecases)
22828	PLIERS - piston snap ring	A-23858	TOOL-crankcase to drivecase assembly
23528	WRENCH - socket screw (conn. rod)	23844	SLEEVE - crankcase assembly
23756	BEARING ASSEMBLY & REMOVAL - conn. rod	23843	SLEEVE - drivecase assembly
23757	BEARING ASSEMBLY & REMOVAL drive and crankcases	23845	PLUG - drivecase assembly
23819	PLUG - needle bearing (sprocket)	23846	ANVIL - crankshaft installation
23758	SEAL ASSEMBLY - drive and crankcases	23136	BODY - jackscrew
23759	SLEEVE - crankshaft assembly	A-23137	JACKSCREW
A-23761-A	REMOVER AND LOCKING BRACKET - rotor	22820-1	COLLAR - bearing
A-23696	REMOVER - threaded spider	23884	SLEEVE - crankshaft installation
		A-23841	WRENCH - insert (guide bar stud)
			PAINT
		22771	SPRAY CAN - red
		23343	SPRAY CAN - green
		23560	SPRAY CAN - white

# HOMELITE **XL-660** AUTOMATIC CHAIN SAW

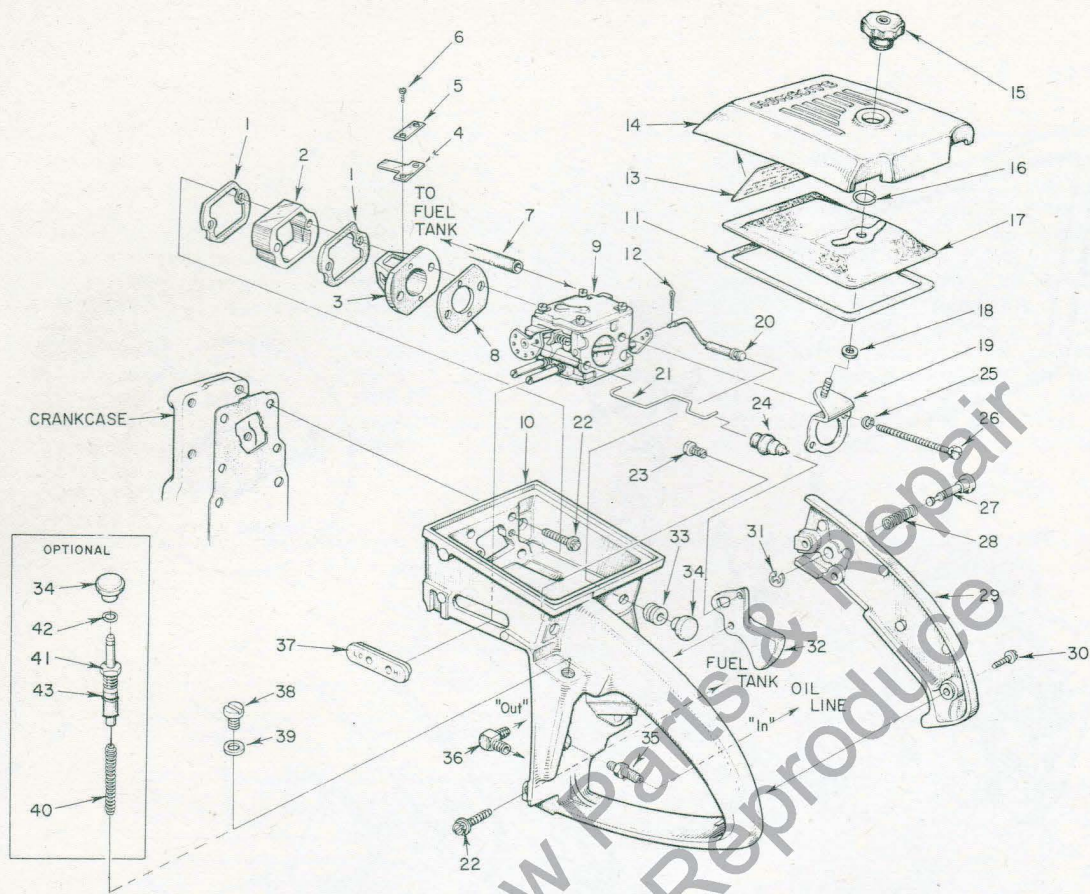

FIGURE 3

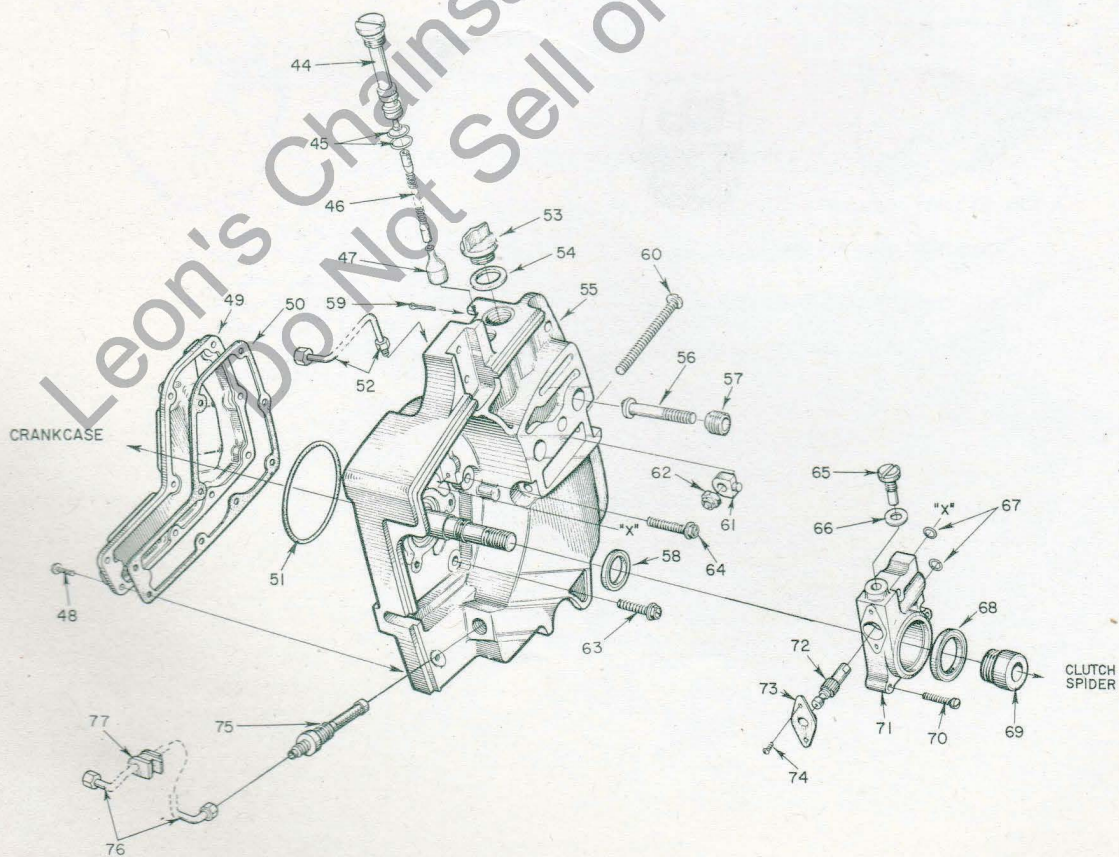
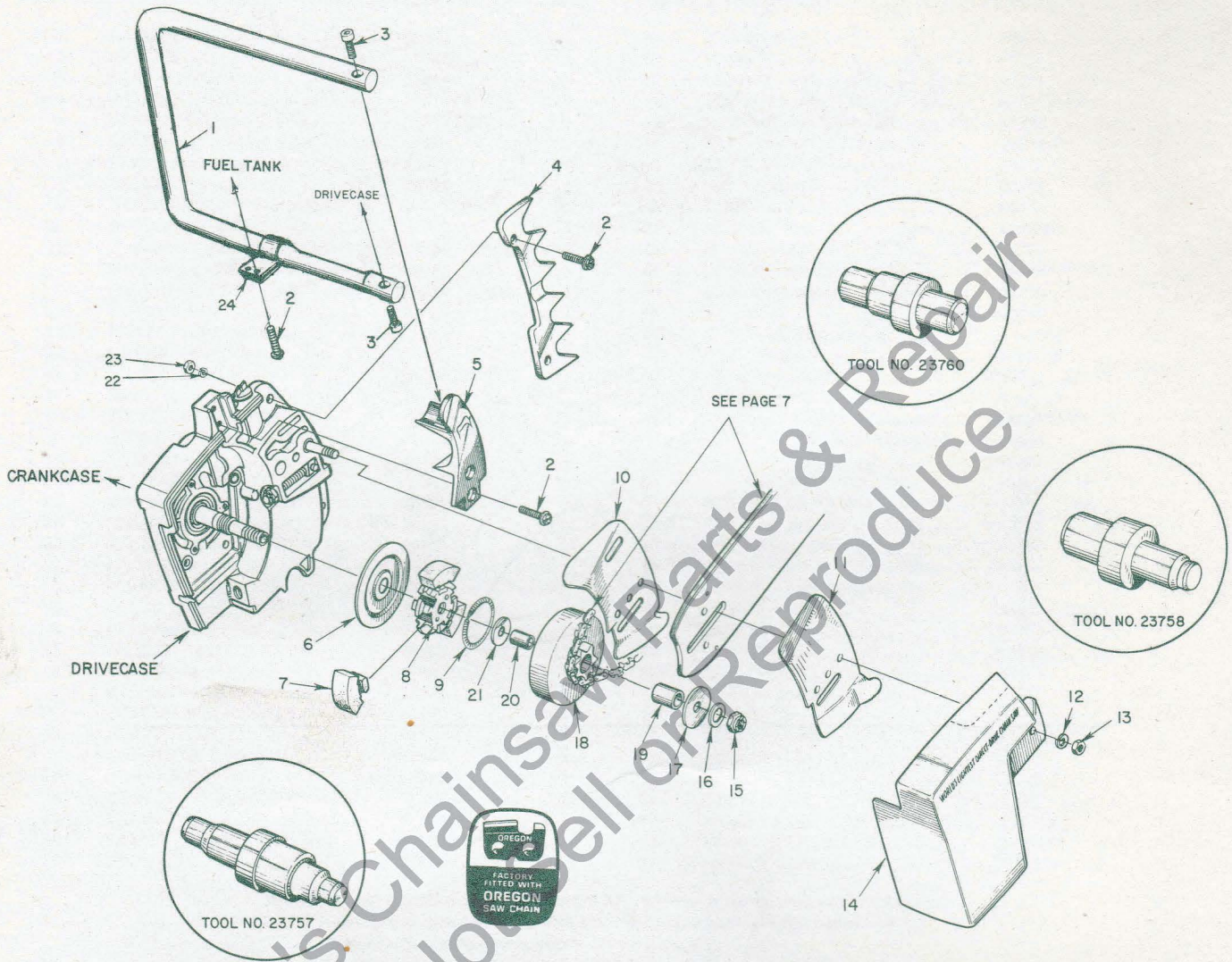

FIGURE 4

# HOMELITE **XL-660** CHAIN SAW AUTOMATIC

FIGURE 5



# HOMELITE XL-660 AUTOMATIC CHAIN SAW

No.	Description	Part No.	Qty.	No.	Description	Part No.	Qty.
1	HANDLE BAR.....	A-63276-2	1	14	COVER - drive case.....	58750-2	1
2	SCREW - hex, 12-24 x 3/4 ....	80867	6	15	NUT - lock, 3/8-24.....	81192	1
3	SCREW - socket.....	80428	2	16	WASHER - flat, 3/8.....	84010-1	1
4	BUMPER PLATE.....	58961	1	17	WASHER - thrust (outer).....	58926	1
5	BRACKET - handle bar.....	59651-2	1	18	SPROCKET & DRUM - See NOTE.		
6	COVER - clutch.....	58751	1		standard - 7 tooth, 3/8" pitch....	A-59552	1
7	SHOE - clutch.....	58928	6		optional - 7 tooth, .404 pitch....	A-59555	1
8	SPIDER - clutch.....	58927-1	1	19	Includes: BEARING - needle.....	72311	1
9	SPRING - clutch.....	55123-C	2	20	RACE - inner.....	55584	1
10	PLATE - inner guide bar.....	58781	1	21	WASHER - thrust (inner).....	58833	1
11	PLATE - outer guide bar.....	58782	1	22	WASHER - lock, #12.....	83056	2
12	WASHER - lock, 5/16.....	83002	2	23	NUT - 12-24.....	81068	2
13	NUT - hex, 5/16-18.....	81196	2	24	CLAMP - handle.....	63291	1

NOTE: Standard 3/8" pitch sprockets used with 3/8" pitch chain, optional .404 pitch sprockets require .404 pitch chain. See below.

GUIDE BARS - .050 gauge					.050 gauge CHAIN 3/8" pitch		
Hard Track		Perma-Hard Tip		≠ Roller Nose			
Part No.	Size	Part No.	Size	Part No.	Size	Part No.	Loop Links
HT-1250	12"	GW-1250	12"			72D-48E	12" 48
		GW-1650	16"	RN-1650	16"	72D-59E	16" 59
		GW-2050	20"	RN-2050	20"	72D-69E	20" 69
		GW-2450	24"	RN-2450	24"	72D-81E	24" 81
		GW-3050	30"	RN-3050	30"	72D-108E	30" 108
≠ #A-59925 - Roller Guide & Rivet Kit - includes three #59344 rivets.							
						.063 gauge CHAIN .404 pitch	
						52AC3-73E 14" 73 (14" Bow Guide)	

### ACCESSORIES (available on order)

- #A-52971-A BOW GUIDE - includes #59194 CHAIN GUARD, #59324 SPUR with parts listed below. Use #72D-81E CHAIN.
- #A-52972-A UTILITY GUIDE - includes #59103 CHAIN GUARD, #59343 SPUR with parts listed below. Use #72D-69E CHAIN.
- #A-52994-A CLEARING GUIDE - includes #59103 CHAIN GUARD, #59343 SPUR with parts listed below. Use #72D-81E CHAIN.
- #A-53024-A BOW GUIDE, 14", .063 - includes #59194 CHAIN GUARD, #59324 SPUR with parts listed below. Use #52AC3-73E CHAIN.

#### GUIDE ATTACHMENT PARTS:

#75729	SPACER - spur.....	1
#80546	SCREW - hex hd., 5/16 x 1-1/4 ....	2
#81112	NUT - hex 5/16.....	2
#80676	SCREW - hex hd., 12-24 x 5/8 ....	2
#83056	WASHER - lock, #12.....	2
#81068	NUT - hex #12.....	2

**You'll  
SPEED WORK  
and make  
MORE MONEY  
with...**

# HOMELITE

**SELF-PRIMING PUMPS**



**DEPENDABLE GENERATORS**



**POWERFUL ONE-MAN CHAIN SAWS**



**ONE-MAN CONCRETE VIBRATORS**



**ELECTRIC BUILDER'S HAMMERS**



Printed in United States of America  
Part No. 23905

## HOMELITE

A **Textron** DIVISION

PORT CHESTER, N. Y.