

PRICE.25

PARTS LIST
REV.6

HOMELITE®

XL-1



Leon's Chainsaw Parts & Repair
Do Not Sell or Reproduce



PART NO. 24323T
REV. 6/74

TERRY INDUSTRIES
A DIVISION OF **textron** CANADA LIMITED

180 Labrosse Ave., Pointe Claire, Que.



Homelite XL-1

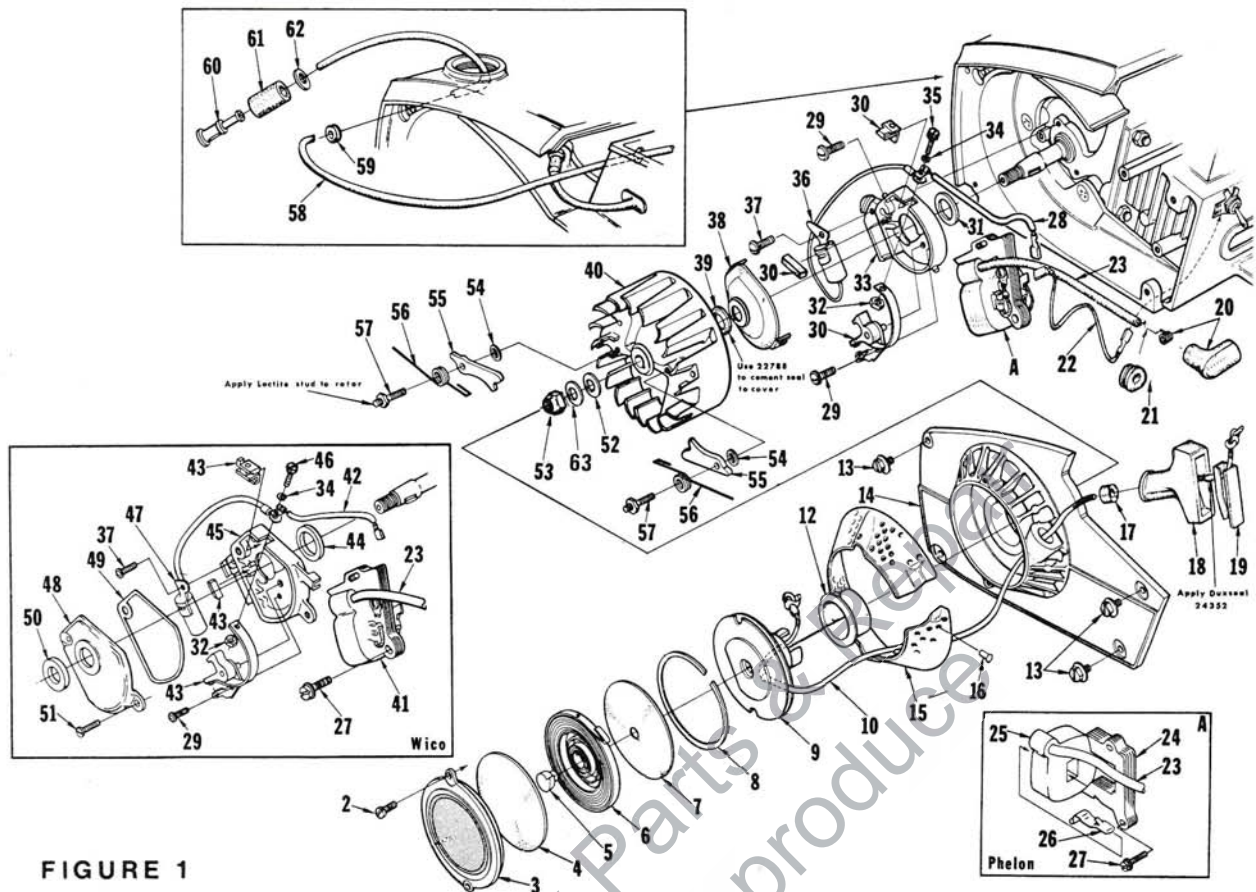

FIGURE 1

No.	Description	Part No.	Qty.	No.	Description	Part No.	Qty.
2	SCREW-pan, 8-32 x 3/8	80577	2	34	WASHER-lock, #6	83004-1	1
3	COVER-starter	65095-2	1	35	SCREW-hex, 6-32 x 7/16	(P) 67628	1
4	SHIELD-spring (inner)	65113	1	36	CONDENSER	(P) 65286	1
5	LOCK-spring	65102	1	37	SCREW-pan, 6-32 x 1/2	80630	1
6	SPRING-rewind	65107	1	38	COVER-breaker box	(P) A-65210-A	1
7	SHIELD-spring (outer)	65114	1	39	Includes: SEAL-felt	(P) 65211	1
8	RING-retaining	65125	1	40	ROTOR-magneto		1
9	PULLEY & CUP	A-65170	1		ROTOR-magneto	(W) 68701	1
10	ROPE-starter, 46"	65118	1	41	COIL & CORE	(W) 68716	1
12	BUSHING-starter cup	68244	1	42	LEAD GROUP-primary	(W) 68712	1
13	SCREW-hex, 10-32 x 5/8	80704	4	43	POINTS-breaker	(W) A-68710	1
14	HOUSING-rewind starter	A-65222-T	1		Includes:		
	Includes:			44	SEAL-felt	(W) 68705	1
15	SCREEN-air inlet	65189	1		WASHER-thrust (not shown)	(W) 28028	as req'd
16	STUD-drive #2	67191	3		LOCK-breaker arm (not shown)	(W) 28008	1
17	BUSHING-starter rope	65185	1	45	BOX-breaker	(W) 69508	1
18	GRIP-starter rope	65183	1	46	SCREW-hex, 6-32 x 1/2	(W) 68700	1
19	INSERT-rope retaining	68837-T	1	47	CONDENSER	(W) 68711	1
20	TERMINAL-spark plug	A-33055	1	48	COVER-breaker box	(W) A-69507	1
21	GROMMET-hi-tension lead	75036	1		Includes:		
22	LEAD-ground	A-63939	1	49	GASKET-breaker box cover	(W) 69512	1
23	LEAD-hi-tension	65205	1	50	SEAL-felt	(W) 68773-1	1
24	CORE-coil	(P) 68255	1	51	SCREW-cover mounting	(W) 68715	2
25	COIL-ignition	(P) 68256	1	52	WASHER-flat, 5/16	84065-1	1
26	RETAINER-coil	(P) 68257	1	53	NUT-hex, 5/16-24	81117	1
27	SCREW-coil core	82248	2	54	WASHER-Lock	83046	2
28	LEAD GROUP-primary	(P) 65291	1	55	PAWL-starter	65108	2
29	SCREW-pan, 6-32 x 3/8	80571	2	56	SPRING-starter pawl	65120	2
30	POINTS-breaker	(P) A-65203-A	1	57	STUD-starter pawl	65109	2
31	Includes: SEAL-felt	(P) 65209	1	58	LINE-fuel	A-68053-A	1
32	NUT	65207	1	59	Includes: GROMMET	68046	1
33	BOX-breaker	(P) 65206-A	1	60	FILTER-fuel	A-63920	1
				61	Includes: FILTER-felt	64083-1	1
				62	WASHER	64182	1
						(P) Phelon (W) Wico	
				63	WASHER-lock	83002	1

Complete magneto must be either Wico or Phelon. Phelon and Wico parts are not individually interchangeable.

Homelite XL-1

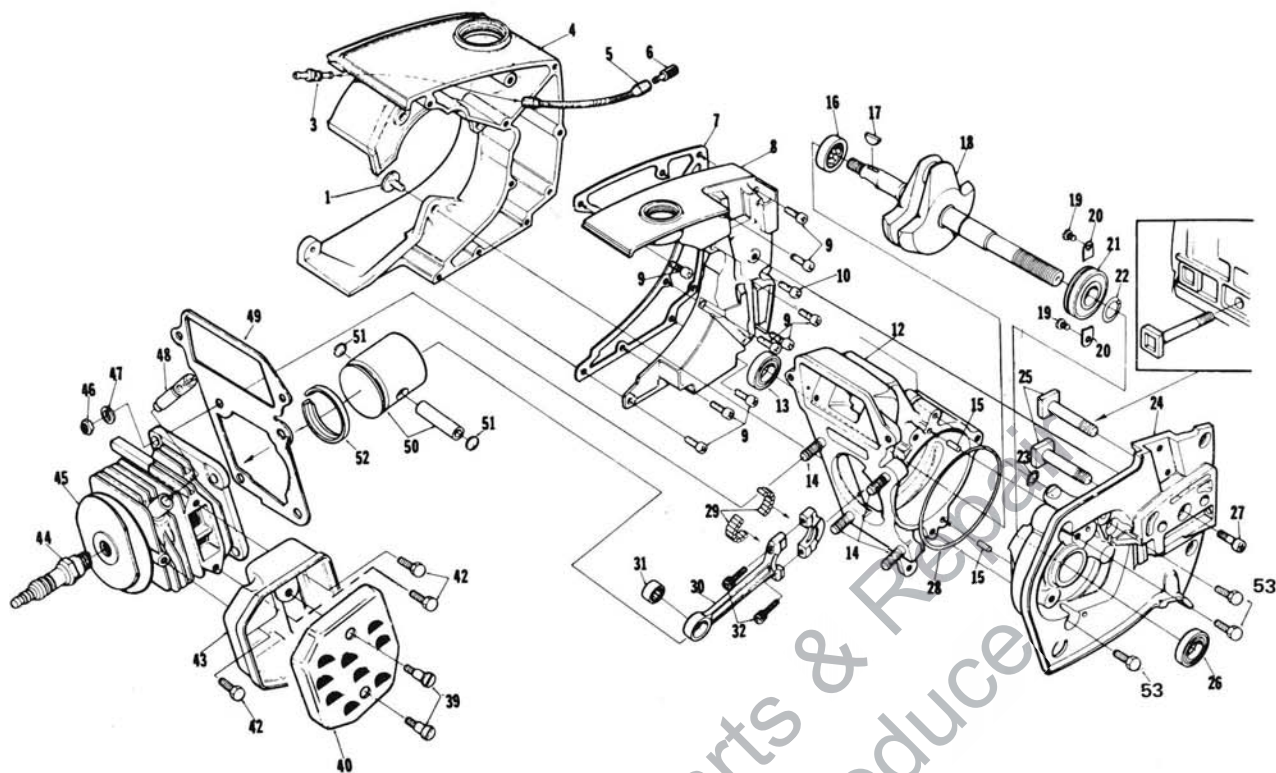

FIGURE 2

No.	Description	Part No.	Qty.	No.	Description	Part No.	Qty.
1	SCREW - retaining	65321	3	24	DRIVECASE	A-65200BT	1
3	FITTING - oil line	65138	1	25	Includes: BOLT - guide bar	65025	2
4	TANK - fuel and oil	A-122400	1	26	SEAL	65019	1
5	LINE - oil (pickup)	58340-B	1	27	SCREW - fil., drivecase retainer	65157	1
6	FILTER - oil	A-65172	1	28	"O" RING	65127	1
7	GASKET - fuel and oil tank	65046	1	29	BEARING - needle (set of 28)	A-65009	1
8	COVER - fuel and oil tank	65115-2T	1	* 30	ROD - connecting	A-68051	1
* 9	SCREW - fil., # 8 x 5/8	122228	9	* 31	Includes: BEARING - needle	68512	1
* 10	SCREW - fil., # 8 x 1-1/2	122399	1	32	SCREW - socket, 8-32 x 9/16	80805	2
* 12	CRANKCASE	A-69260	1	39	SCREW - shoulder	64133-A	2
13	Includes: SEAL	65019	1	40	CAP - muffer	68253-1	1
14	STUD - cylinder	55871	4	42	SCREW - hex, 10-32 x 1/2	80648	3
15	PIN - dowel	65153	2	43	BODY - muffer	A-65152-2	1
16	BEARING - roller	65179	1	* 44	SPARK PLUG	65130-S	1
17	KEY - woodruff	65126	1	* 45	CYLINDER - (1-9/16" dia.)	A-122327	1
18	CRANKSHAFT	65006-2	1	46	NUT - hex, 1/4-28	81065-2	4
19	SCREW - bearing retaining	59704	2	47	WASHER - lock, 1/4	83009	4
20	WASHER - lock special	63905	2	48	VALVE - compression release	A-65184	1
21	BEARING - ball	65044-S	1	49	GASKET - cylinder	65018	1
22	RING - retaining	65045	1	* 50	PISTON & PIN - (1-9/16" dia.)	A-68487	1
23	"O" RING	59074	1	* 51	Includes: RING - piston pin retain.	64813	2
				* 52	PISTON RING	68508	2
				53	SCREW - Hex. Hd., 12-24 x 5/8	80676	3

* Denotes new parts

ALWAYS FURNISH SAW MODEL AND SERIAL NUMBER WHEN ORDERING PARTS.

Homelite XL-1

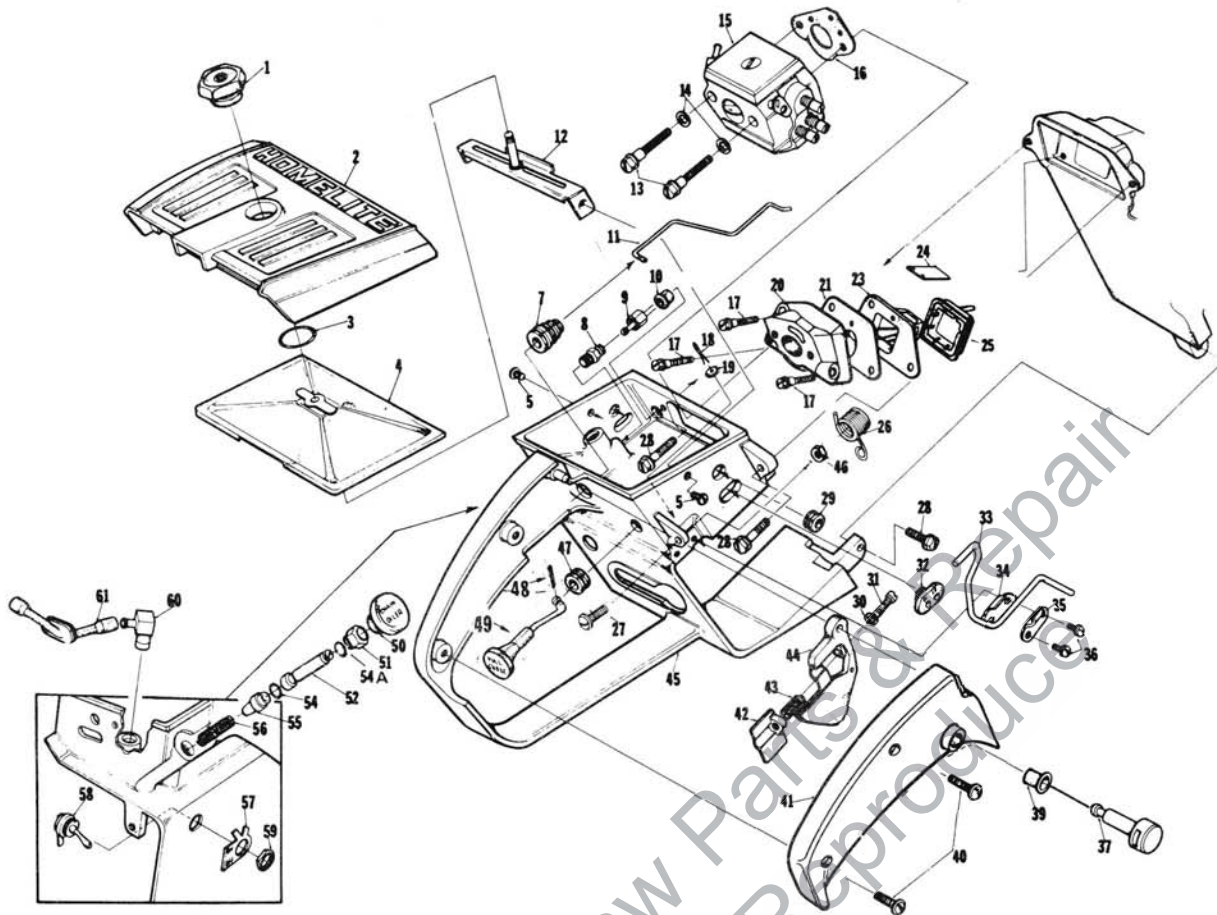

FIGURE 3

No.	Description	Part No.	Qty.	No.	Description	Part No.	Qty.
1	NUT - cover mounting	A-65272	1	32	GROMMET - "Hi - Lo"	68196	1
2	COVER - air filter	65096-3	1	33	LEVER - release	65173	1
3	RING - retaining	58319-A	1	34	PLATE - lever	65092	1
4	FILTER ELEMENT - air	A-65178	1	35	CLAMP - lever	65093	1
5	SCREW - pan, 8-32 x 3/8	80577	2	36	SCREW - pan, 6-32 x 3/8	80571	2
7	BOOT - throttle rod	67694	1	37	PIN - trigger latch	65171-A	1
8	VALVE - check	A-65077-T	1	39	BUSHING	67752	1
9	LINE - oil	A-65214	1	40	SCREW - pan, 8-32 x 1/2	80560	2
10	GROMMET - oil line	65085	1	41	COVER - throttle handle	65042-2B	1
11	ROD - throttle	65056	1	42	STOP - throttle adjustment	65147-A	1
12	BRACKET - air filter cover	A-65123	1	43	SPRING - throttle stop	65188	1
13	SCREW - hex, 10-32 x 1-5/8	82165	2	44	TRIGGER - throttle	65031	1
14	WASHER - lock, #10	83046	2	45	HANDLE - throttle (see note)	A-65215-ET	1
15	CARBURETOR	A-68415	1	46	NUT, Hex (#10 - 32)	81010	1
16	GASKET - carburetor	65016	1	47	GROMMET	64862	1
17	SCREW - shoulder	64349-A	3	48	PIN - cotter	86324	1
18	PIN - cotter	86301	1	49	ROD - choke	65072-1	1
19	WASHER - felt	63290	1	50	BUTTON	57289-1	1
20	SPACER - reed valve	A-65154-1A	1	51	NUT - plunger	121293	1
21	GASKET - reed valve seat	65014	1	52	ROD - plunger	A-65199-T	1
22	SEAT - reed valve	65010	1	54	Includes: "O" RING	58406	1
23	SEAT - reed valve	65010	1	54A	"O" RING	59074	1
24	REED - valve	65012-A	4	55	PLUNGER - oil pump	65081-AT	1
25	RETAINER - reed valve	65011-A	1	56	SPRING - plunger	65080	1
26	SPRING - release valve	65174	1	57	PLATE - indicating "On-Off"	63910	1
27	SCREW	80040	1	58	SWITCH - grounding	A-63938	1
28	SCREW - hex, 10-24 x 5/8	80676	3	59	Includes: NUT - hex	72084-A1	1
29	GROMMET - idle adjustment	68197	1	60	VALVE - check (inlet)	A-65076	1
30	O-Ring	65260	1	61	LINE - oil	65137	1
31	SCREW - pan, hd., 6-40 x 1	82198	1				

Homelite XL-1

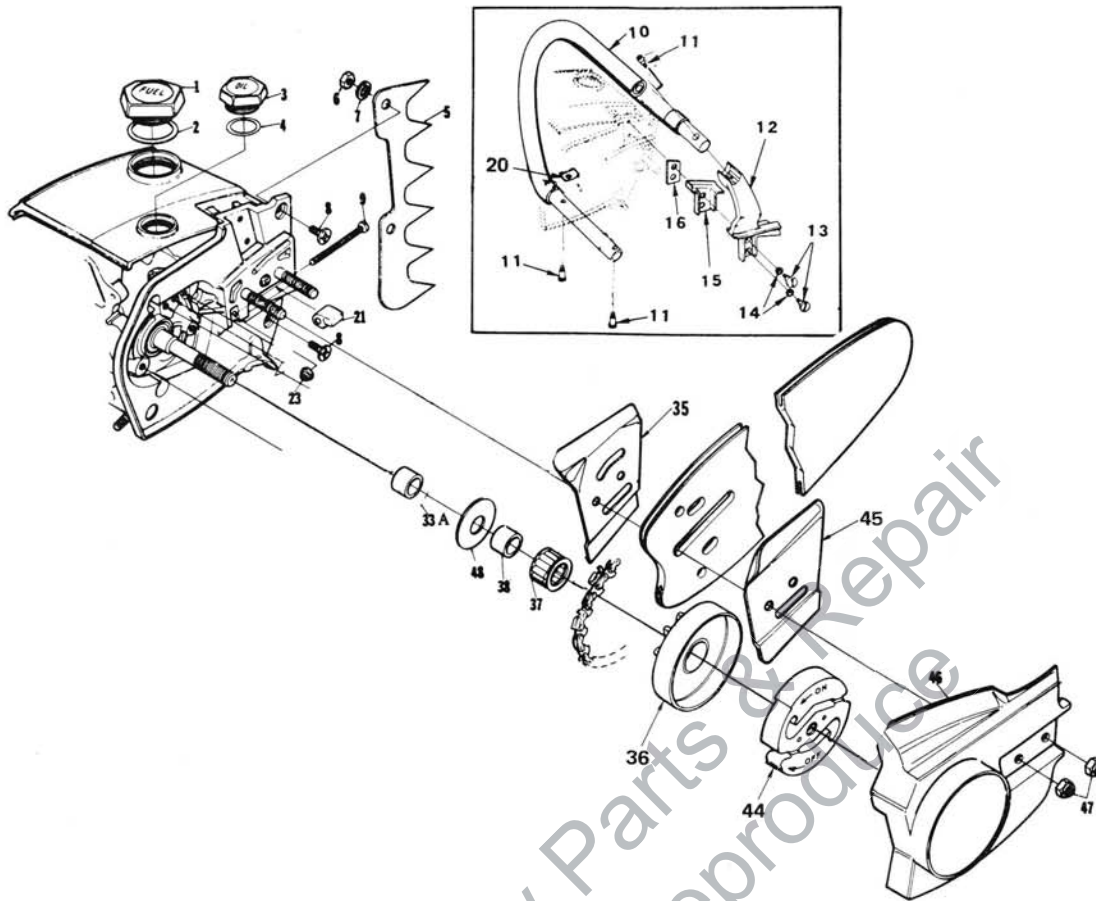

FIGURE 4

No.	Description	Part No.	Qty.	No.	Description	Part No.	Qty.
1	CAP - fuel filler, incl. VALVE - check (not shown)	A-69500 69451	1 1	20	WASHER	69890	1
2	GASKET - cap fuel filler	69501	1	21	PIN - bar adjusting	65112-1	1
3	CAP - oil filler (vented) Includes: VALVE - check (not shown)	A-65284-B 69451	1 1	23	NUT - lock, 10-32	81206	1
4	GASKET	69834	1	33-A	SPACER	121286	1
† 5	KIT - spiked bumper	A-65181	1	35	PLATE - guide bar (inner)	63638-B	1
† 6	Includes: NUT - hex, 10-32	81010-1	2	36	SPROCKET & DRUM	A-121505	1
† 7	WASHER - lock, #10	83006-1	2	37	Incl. BEARING - needle	64333	1
† 8	SCREW - flat, 10-32 x 5/8	80035	2	38	RACE - inner	69423	1
9	SCREW - guide bar adjusting	65175-A	1	44	Clutch "S" Type	68362-1	1
10	HANDLE BAR - flush cut Incl.	A-122370	1	45	PLATE - guide bar (outer)	63639-A	1
11	SCREW - Fil., 10-32 x 1	80041	3	46	COVER - drivecase	65131-1T	1
12	BRACKET - handle bar	65035-2	1	47	NUT - hex, 5/16-18	81196	2
13	SCREW - shoulder	64613-A	2	48	WASHER - thrust (outer)	65064	1
14	GROMMET - handle bar	64473	2				
15	MOUNT - shock	65111	1				
16	PLATE - handle bar bracket	65032	1				

† Optional



Homelite XL-1

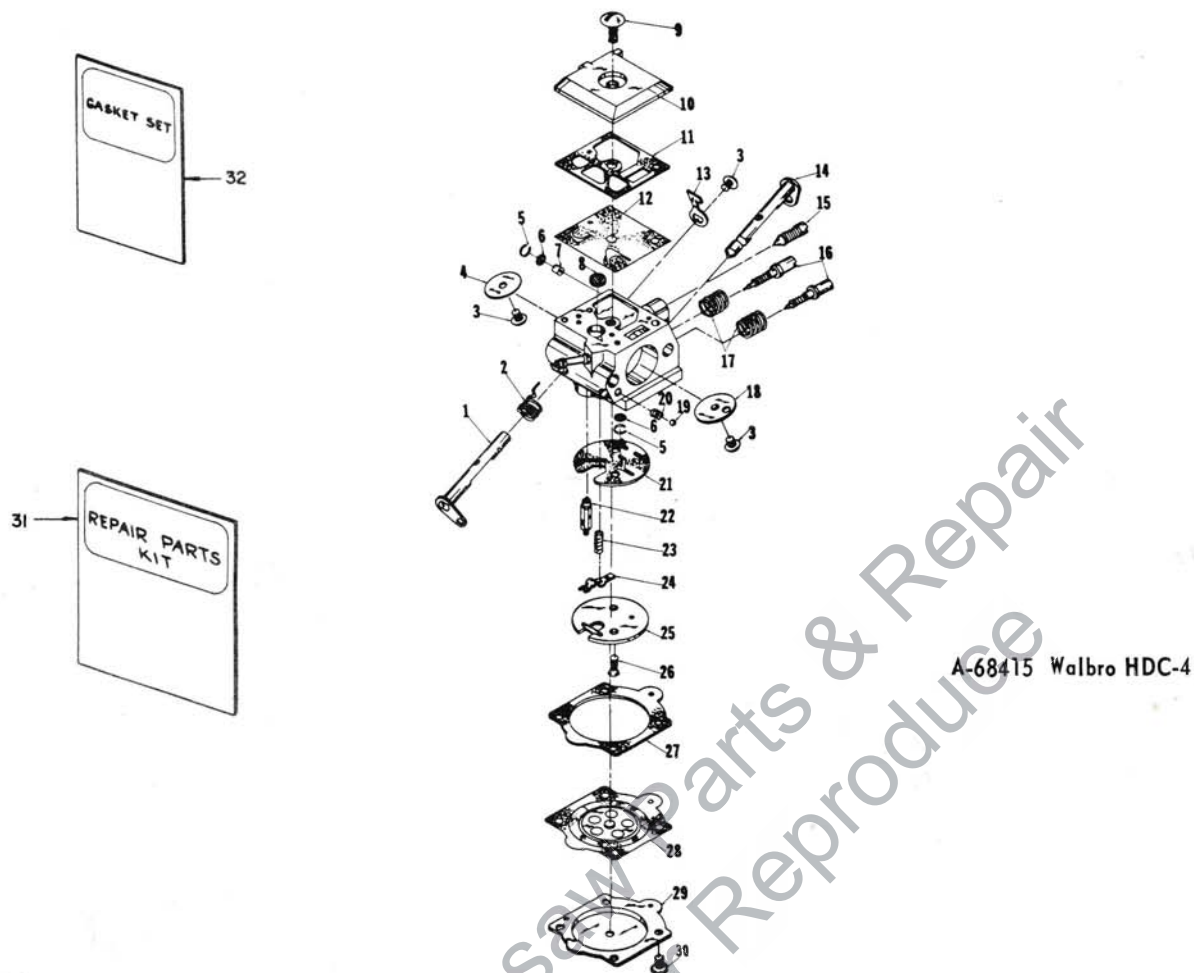

No.	Part No.	Description	Qty.	No.	Part No.	Description	Qty.
1	67362	SHAFT - throttle	1	17	67377 †	SPRING - needle adjusting	2
2	67376 †	SPRING - throttle return	1	18	67365	VALVE - choke	1
3	67372 †	SCREW - valve	3	19	60051 †	BALL - choke friction	1
4	67363	VALVE - throttle	1	20	64238 †	SPRING - choke friction	1
5	67360 †	RING - screen retaining	2	21	67367A ‡	GASKET - circuit	1
6	67381 †	SCREEN - check valve	2	22	64229 †	VALVE - inlet needle	1
7	68461	JET - limiting	1	23	67378 †	SPRING - metering lever	1
8	64243 †	SCREEN - fuel inlet	1	24	67383 †	LEVER - metering	1
9	67374	SCREW - fuel pump cover	1	25	67382	PLATE - circuit	1
10	67361	COVER - fuel pump	1	26	67375	SCREW - circuit plate	2
11	67368 ‡	GASKET - fuel pump	1	27	64231 ‡	GASKET - metering diaphragm	1
12	67370 †	DIAPHRAGM - fuel pump	1	28	67371 †	DIAPHRAGM - metering	1
13	67366	STOP - throttle	1	29	64224	COVER - metering diaphragm	1
*14	67364	SHAFT - choke	1	30	64689	SCREW - metering cover	4
*15	67373	SCREW - idle adjustment	1	31	67384	REPAIR KIT	1
*16	67379 †	NEEDLE - idle adjustment	2	32	67369A †	GASKET SET	1
					65386	REPAIR KIT - check valve	1

†Indicates contents of Repair Kit #67384

‡Indicates contents of Gasket Set

*Denotes new parts

TOOLS

24299	ANVIL - crankshaft installation		23136-1	BODY - fixture	
24300	SLEEVE - crankshaft bearing	24320	BIT - #3 pozidriv	24295	COLLAR - bearing
24294	PLUG - needle bearing assembly	A-24284-T	WRENCH - combination	A-24309	JACKSCREW
24292	PLUG - seal removal	A-24290	BRACKET - rotor remover	24291	SLEEVE - seal (drivecase)
24298	PLUG - bearing and seal	*A-23696	WRENCH - clutch (spanner)	24297	SLEEVE - seal (crankcase)

PAINT

24101 SPRAY CAN - Blue

ALWAYS FURNISH SAW MODEL AND SERIAL NUMBER WHEN ORDERING PARTS.