

# **HOMELITE®**

**XL-123**

**XL-123-2**

**CHAIN SAW**

**HOMELITE®**

**A textron  
DIVISION**



# XL-123 XL-123-2

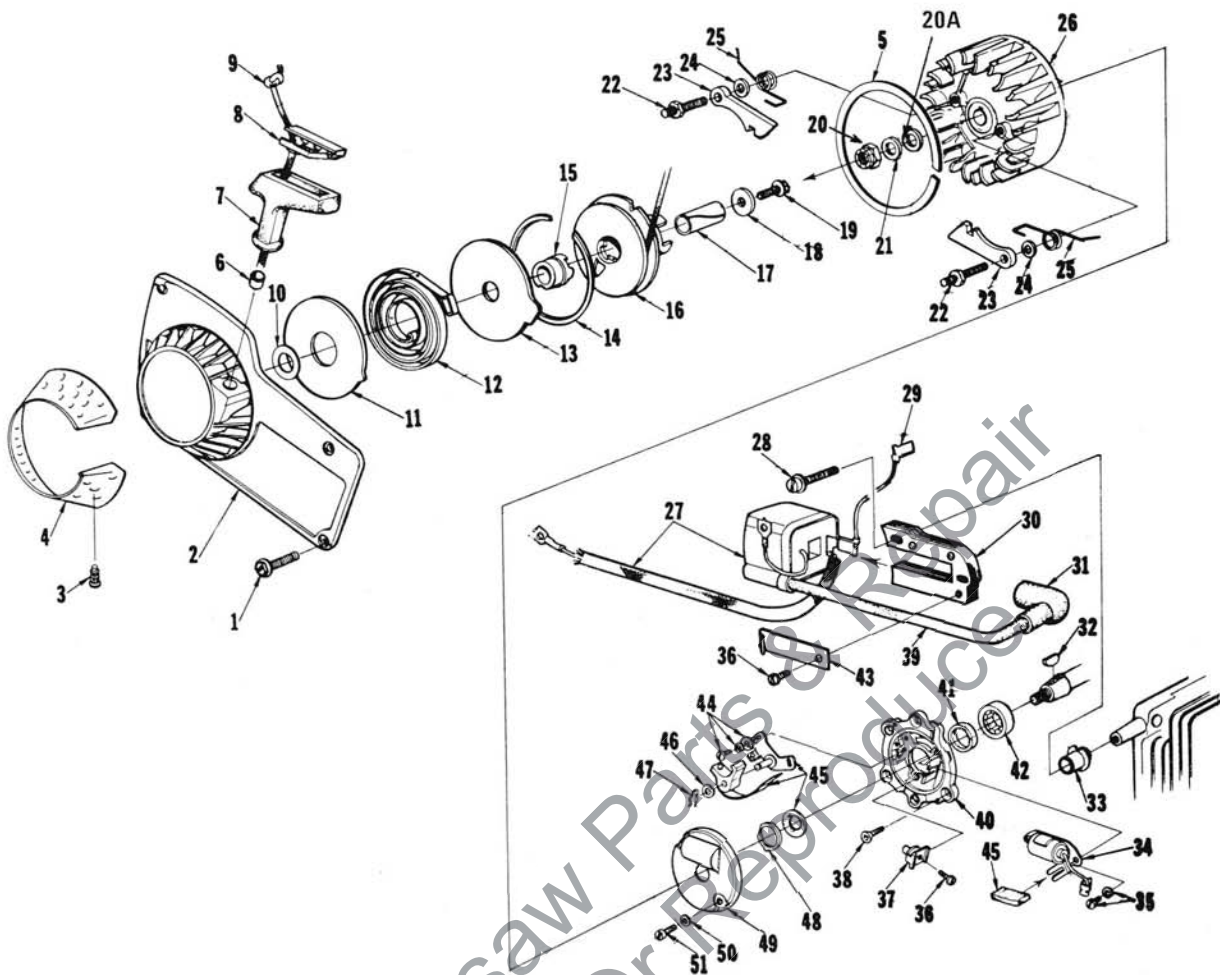
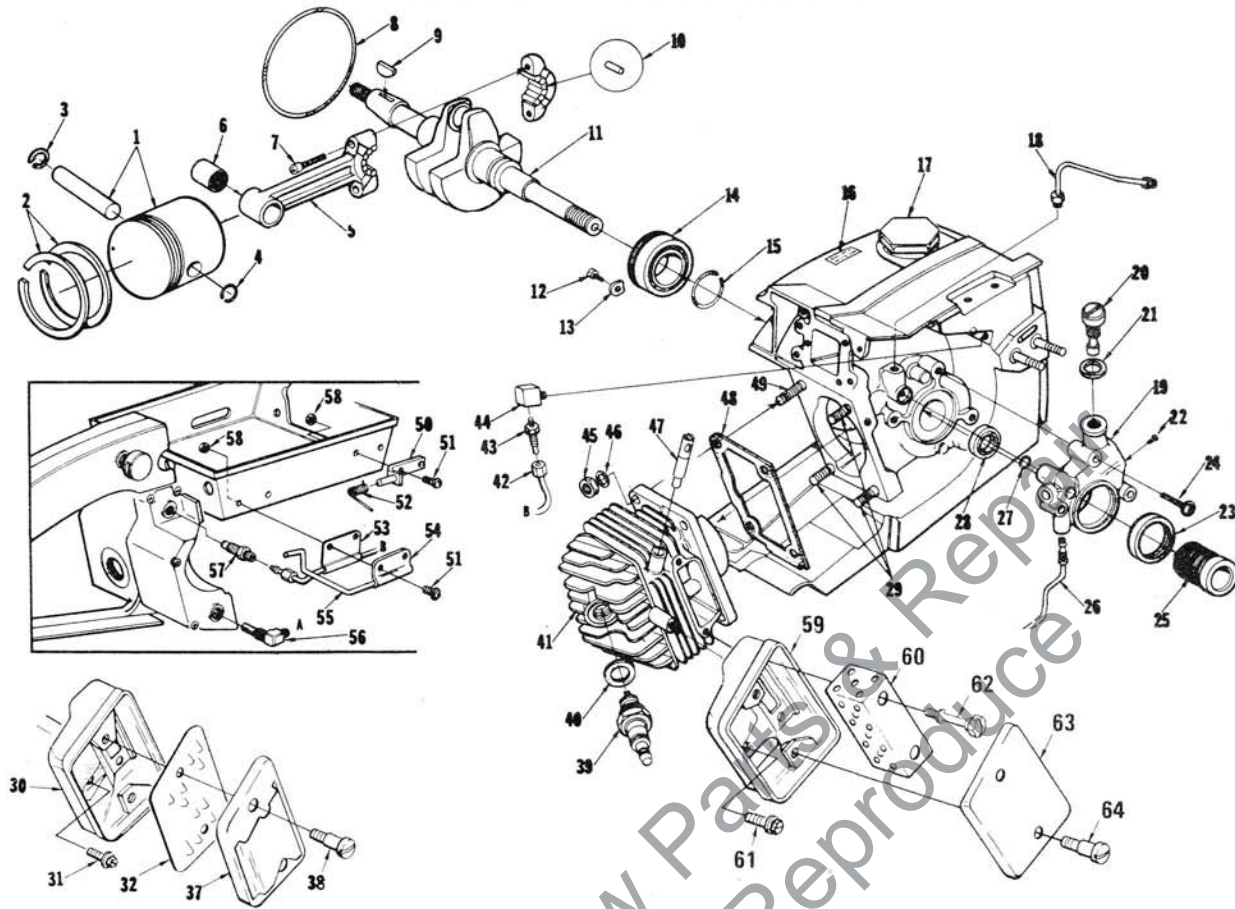

**FIGURE 1**

No.	Description	Part No.	Qty.	No.	Description	Part No.	Qty.
1	SCREW-hex, 10-32 x 1/2	80648	4	27	COIL-ignition	64091	1
2	HOUSING-fan	A-67192-A	1	28	SCREW-coil core	64021	2
3	Includes: STUD-drive	67191	4	29	LEAD-ground to switch	A-63939	1
4	SCREEN-fan housing	65491	1	30	CORE-coil	54422	1
5	RING-air flow	67222	1	31	TERMINAL-spark plug	A-33055	1
6	BUSHING-starter rope	67177	1	32	KEY-woodruff	75078	1
7	GRIP-starting rope	64155-A	1	33	RETAINER-lead	64301	1
8	INSERT-rope retaining	68837	1	34	CONDENSER & CLAMP	64086	1
9	ROPE-starter	63869	1	35	SCREW-condenser clamp	55411	2
10	WASHER	67185	1	36	SCREW	64090	2
11	SHIELD-spring (inner)	63713	1	37	BLOCK-terminal	64088	1
12	SPRING-rewind	63870	1	38	SCREW-back plate retainer	65321	5
13	SHIELD-spring (outer)	63714	1	39	LEAD-high tension	58966	1
14	RING-shield retaining	63875	1	*40	PLATE-back	A-68142	1
15	LOCK-spring	64948	1	41	Includes: SEAL	58688-A	1
16	PULLEY & CUP ASSEMBLY	A-63952-B	1	42	BEARING-roller	67395	1
17	BUSHING-starter post	64374	1	43	CLIP-coil retaining	54423	1
18	WASHER-retaining	63606	1	44	SCREW-breaker clamp	76421	2
19	SCREW-hex, 10-32 x 1/2	80648	1	45	POINT-set w/felt	A-64087	1
20	NUT, 5/16-24	81117	1	46	Includes: WASHER-post	28028	1
20A	WASHER, lock	83002	1	47	CLIP-post	28008	1
21	WASHER-flat, 5/16	84065-1	1	48	RETAINER-felt	64089	1
22	STUD-shoulder	63877-A	2	49	COVER-breaker box	A-63928	1
23	PAWL-starter	64442	2	50	WASHER-flat #6	84018	2
24	WASHER-lock	83056	2	51	SCREW-cover	64085	2
25	SPRING-starter pawl	65375-1	2				
26	ROTOR-magneto	63637	1				

\*Denotes new parts

# XL-123 XL-123-2



To service older units

FIGURE 2

No.	Description	Part No.	Qty.	No.	Description	Part No.	Qty.
* 1	PISTON & PIN Includes:	A-68438	1	30	BODY-muffler	A-64130-2	1
2	PISTON RING	59436	2	31	SCREW-hex, 12-24 x 1/2	80821	3
3	RING-retaining	75120	1	32	BAFFLE-muffler	68472	1
4	RING-piston pin retaining	64813	1	37	CAP-muffler	A-68951-1	1
* 5	ROD-connecting	A-68498-A	1	38	SCREW -shoulder	64133-A	2
6	Includes: BEARING-needle	67408	1	39	SPARK PLUG	63547-S	1
7	SCREW	80541	2	40	Includes: GASKET	25038	1
* 8	"O" RING	58785	1	*41	CYLINDER	A-65795-1A	1
9	KEY-woodruff	75078	1	42	LINE-oil (manual)	A-67079	1
*10	ROLLER-needle (set of 25)	A-69050	1	43	FITTING-straight	65696	1
*11	CRANKSHAFT	68730	1	44	CONNECTOR-elbow	31734	1
12	SCREW-bearing retainer	59704	2	45	NUT-hex, 1/4-28	81065-2	4
13	WASHER-special	63905	2	46	WASHER-lock, 1/4	83009	4
14	BEARING-ball	63865-S	1	47	PIN-compression release	A-67482	1
15	RING-retaining	58319-A	1	48	GASKET-cylinder	65829	1
16	DECAL	64144	1	49	STUD-cylinder (long)	63868	1
17	CAP-fuel filler	A-65283-B	1	50	PIVOT PIN & BRACKET	A-64656-2	1
18	LINE-oil (auto. upper)	A-63919	1	51	SCREW-pan, 6-32 x 3/8	80571	4
19	PUMP-automatic oil Includes:	A-67023	1	52	SPRING-relief valve	64653	1
20	SCREW-cam	64102-A	1	53	CLAMP-oil	65949-2	1
21	GASKET	59736	1	54	CLAMP-lever	64655-2	1
22	SCREW-pan, 4-40 x 1/4	80919	2	55	LEVER-relief valve	64654-B	1
23	SEAL-felt	64393	1	56	FILTER-oil	A-64741	1
24	SCREW-pan, 8-32 x 7/8	80568	3	57	VALVE-check	A-65948	1
25	WORM-oil pump	63228	1	58	NUT-flexlock, 6-32	81126	4
26	LINE-oil (auto. lower)	A-63947	1	59	BODY-muffler	A-69231-1	1
27	"O" RING	59074	1	60	BAFFLE-muffler	69230-1	1
28	SEAL	58308-A	1	61	SCREW-hex, Hd. (†12-24 x 1/2)	80821	1
29	STUD-cylinder (short)	55871	3	62	SCREW-shoulder	68481	2
				63	CAP-muffler	69228-1	1
				64	SCREW-shoulder	64133-A	2

\*Denotes new parts



# XL-123 XL-123-2

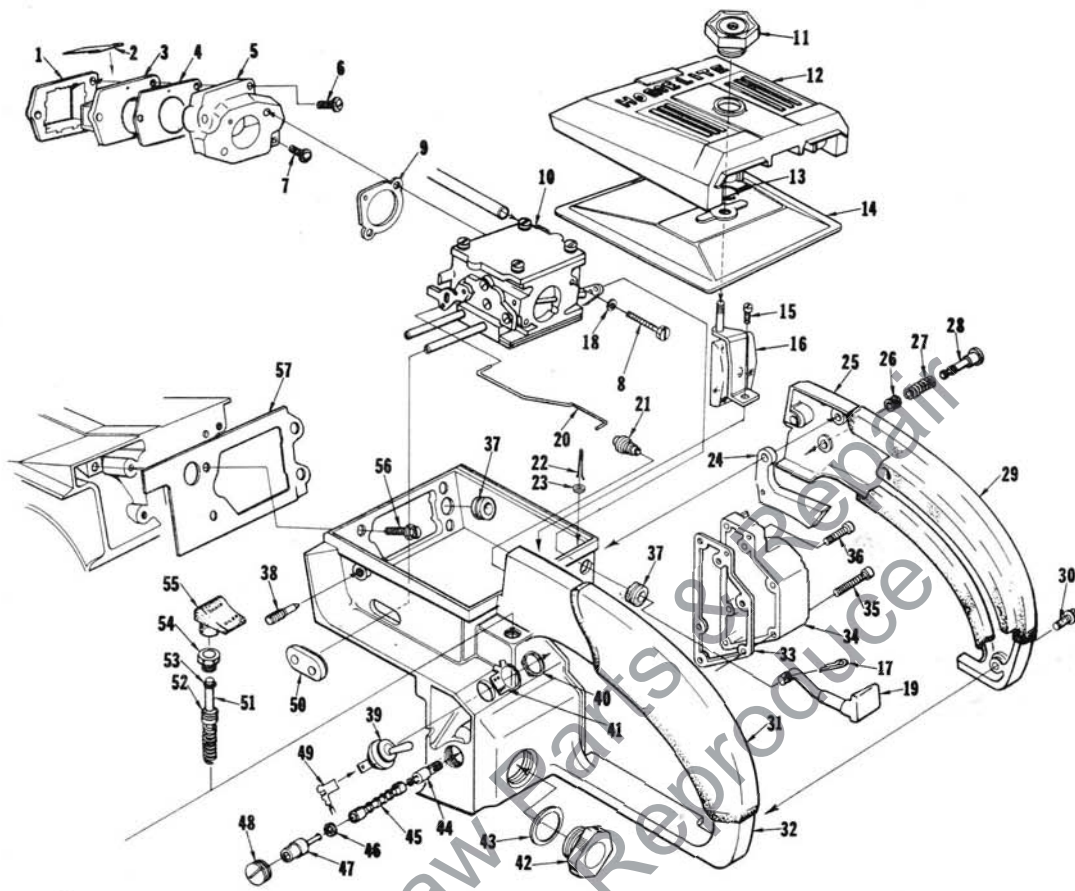

**FIGURE 3**

No.	Description	Part No.	Qty.	No.	Description	Part No.	Qty.
1	RETAINER-reed valve	64253-A	1	*32	HANDLE-throttle	A-68483	1
2	REED-valve	59678-B	4		Includes:		
3	SEAT-reed valve	64252-A	1		RIVET-accordion (not shown)	65889	4
4	GASKET-reed valve seat	64266	1	33	GASKET-oil tank	67265	1
5	MANIFOLD-intake	A-67502-A	1	34	COVER-oil tank	A-68120	1
6	Includes: SCREW-pan, 8-32 x 1-1/4	82174	2		Includes: PLUG-pipe (not shown)	59571	1
7	SCREW-pan, 8-32 x 1	82173	1	35	SCREW-fil, 8-32 x 1-5/8	82153	3
8	SCREW-hex, 10-32 x 1-7/8	82179	2	36	SCREW-fil, 8-32 x 3/4	82156	3
9	GASKET-carburetor	67631	1	37	GROMMET	64862	2
*10	CARBURETOR (SDC-31)	A-68402	1	38	SCREW-idle adjustment	65522	1
11	NUT-cover mounting	A-67627	1	39	SWITCH	A-63938	1
12	COVER-air filter	63183-4	1	40	Includes: NUT	72084-A1	1
13	RING-retaining	58319-A	1	41	PLATE-"On-Off"	63910	1
14	FILTER ELEMENT-air	A-63955-A	1	42	CAP-oil (vented)	A-65284-A	1
15	SCREW-hex, 12-24 x 1/2	80821	1	43	Includes: "O" RING	65133	1
*16	BRACKET-air filter cover	A-68056	1		VALVE-vent (not shown)	63718	1
17	PIN-cotter	86324	1	44	FILTER-oil (manual)	A-64293	1
18	WASHER-lock, #10	83046	2	45	LINE-flexible oil	64356	1
19	ROD-choke	67000-1	1	46	GASKET	59736	1
20	ROD-throttle	63896-A	1	47	FITTING-check valve	A-63936	1
21	BOOT-throttle rod	67634	1	48	SCREW-set	63113	1
22	PIN-cotter	86301	1	49	LEAD-ground	A-63939	1
23	WASHER-felt	63290	1	50	GROMMET-"Hi-Lo"	58858	1
24	TRIGGER-throttle	63212-A	1	51	PLUNGER-oil pump	A-68061-A	1
*25	COVER-throttle handle	63599-5	1	52	Includes: "O" RING	58406	1
26	BUSHING-throttle lock	64646	1	53	"O" RING	59074	1
27	SPRING-throttle lock	64677	1	54	NUT-plunger	65082	1
28	PIN-throttle lock	65592-A	1	55	BUTTON-oil pump	67386	1
*29	GRIP-throttle handle cover	68467	1	56	SCREW-hex, 12-24 x 5/8	80676	4
30	SCREW-pan, 8-32 x 1/2	80560	2	57	GASKET-throttle handle	64267	1
*31	GRIP-throttle handle	68466	1				

\* Denotes new parts

# XL-123 XL-123-2

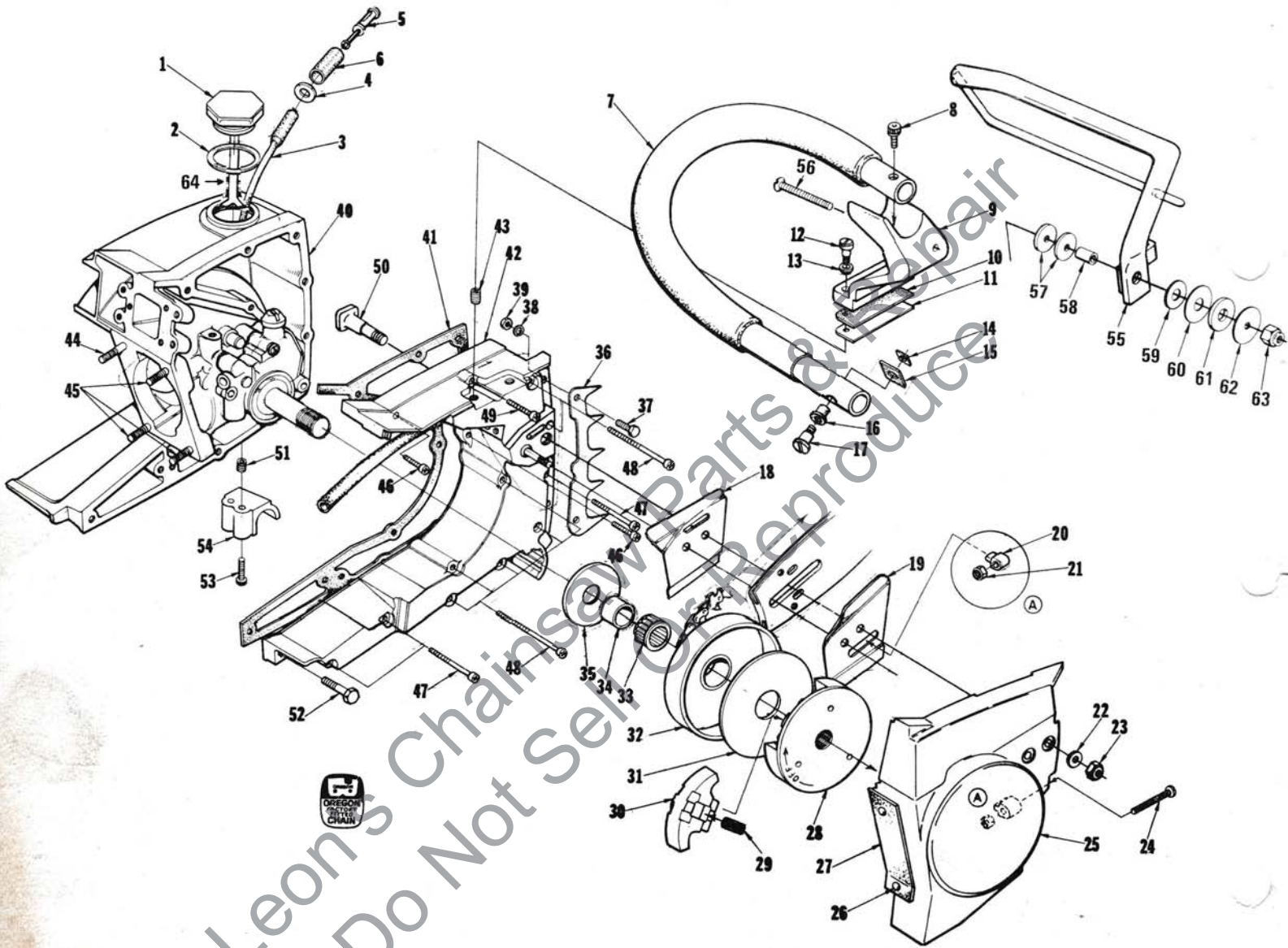

FIGURE 4



# XL-123 XL-123-2

No.	Description	Part No.	Qty.	No.	Description	Part No.	Qty.
1	CAP-fuel filler	A-65283-B	1	*32	SPROCKET & DRUM-3/8 pitch, 7 tooth	A-64908	1
2	Includes: GASKET	68961	1		SPROCKET & DRUM-See Note 1 (optional)	A-68465	1
3	LINE-fuel	63544	1		DRUM & HUB-optional (splined)	A-65988	1
4	WASHER	64182	1		SPROCKET-3/8 pitch, 7 tooth (splined)		
5	FILTER-fuel	A-63920	1		optional	OM68210	1
6	Includes: FILTER-felt	64083-1	1	33	BEARING-cage	64333	1
* 7	HANDLE BAR-flush cut	A-69033-1	1	34	RACE-inner	63990	1
8	SCREW-soc., 10-32 x 1	82126	1	35	WASHER-thrust (inner)	63860	1
* 9	BRACKET-handle bar	A-68341	1	36	BUMPER-spiked	A-64722	1
†*	" handle bar	A-68995	1	37	Includes: SCREW-hex, 12-24 x 5/8	80676	2
10	PAD-bracket	64610	1	38	WASHER-lock, #12	83056	2
11	PLATE-handle bar bracket	65586	1	39	NUT-hex, 12-24	81068	2
*12	SCREW-shoulder	68338	2	*40	CRANKCASE & TANK	A-68439-A	1
13	GROMMET-handle bar bracket	64474	2		Includes: PIN-dowel (not shown)	71430	2
14	PLATE-handle bar	65670	1		PIN-dowel (not shown)	65365	2
*15	PAD-handle bar	68394	1		SEAL-(see fig. 2, Index #28)	58308-A	1
16	GROMMET-handle bar	65122	1	41	GASKET-fuel tank	65364-A	1
*17	SCREW-shoulder	68339	1	42	COVER-fuel tank	A-68040	1
18	PLATE-guide bar (inner)	67300	1		Includes: (not shown)		
19	PLATE-guide bar (outer)	67299	1		GASKET-check valve	58338	1
20	PIN-bar adjusting	65768-1	1		CAP-check valve	58339	1
21	NUT- lock, 10-32	81211	1	43	INSERT-taplock	72489	3
22	WASHER-flat, 5/16	84032	2	44	STUD-cylinder (long)	63868	1
23	NUT-hex, 5/16-18	81196	2	45	STUD-cylinder (short)	55871	3
24	SCREW-guide bar adjusting	65175-A	1	46	SCREW-fil, 8-32 x 15/16	82151	2
25	COVER-drivecase	A-64620-1	1	47	SCREW-fil, 8-32 x 1-7/8	82154	3
26	Includes: RIVET-oval head	85061	2	48	SCREW-fil, 8-32 x 2-3/16	82155	7
27	SHIELD-sawdust	64618	1	49	SCREW-fil, 8-32 x 1-1/4	82152	1
28	PLATE-clutch	64904-1	1	50	BOLT-guide bar	67193	2
29	SPRING-clutch	65842	3	51	INSERT-taplock	72489	2
30	SHOE-clutch	64569-3	3	52	SCREW-hex, 12-24 x 7/8	80891	1
31	COVER-clutch	63671	1	53	SCREW-pan, 10-32 x 5/8	80572	2
	* Denotes new parts			54	STOP-handle bar	67506-2	1

†For XL-123-2 only.

Note 1 - Sprocket & Drum A-68465 requires the use of one (1) 65985 Inner Race and one (1) 64124 Needle Bearing for proper assembly.

†55	GUARD-anti kickback	A-68932-1	1
†56	SCREW-flat hd (#12-24 x 1-1/2)	82223	1
†57	WASHER-flat	84006-1	2
†58	BRUSHING	68934-1	1
†59	WASHER-flat	84099	1
†60	WASHER-flat	68939-1	1
†61	WASHER	68935	1
†62	WASHER-flat	68940-1	1
†63	NUT (#12-24)	81222	1
†64	RETAINER	68751	1

# XL-123 XL-123-2

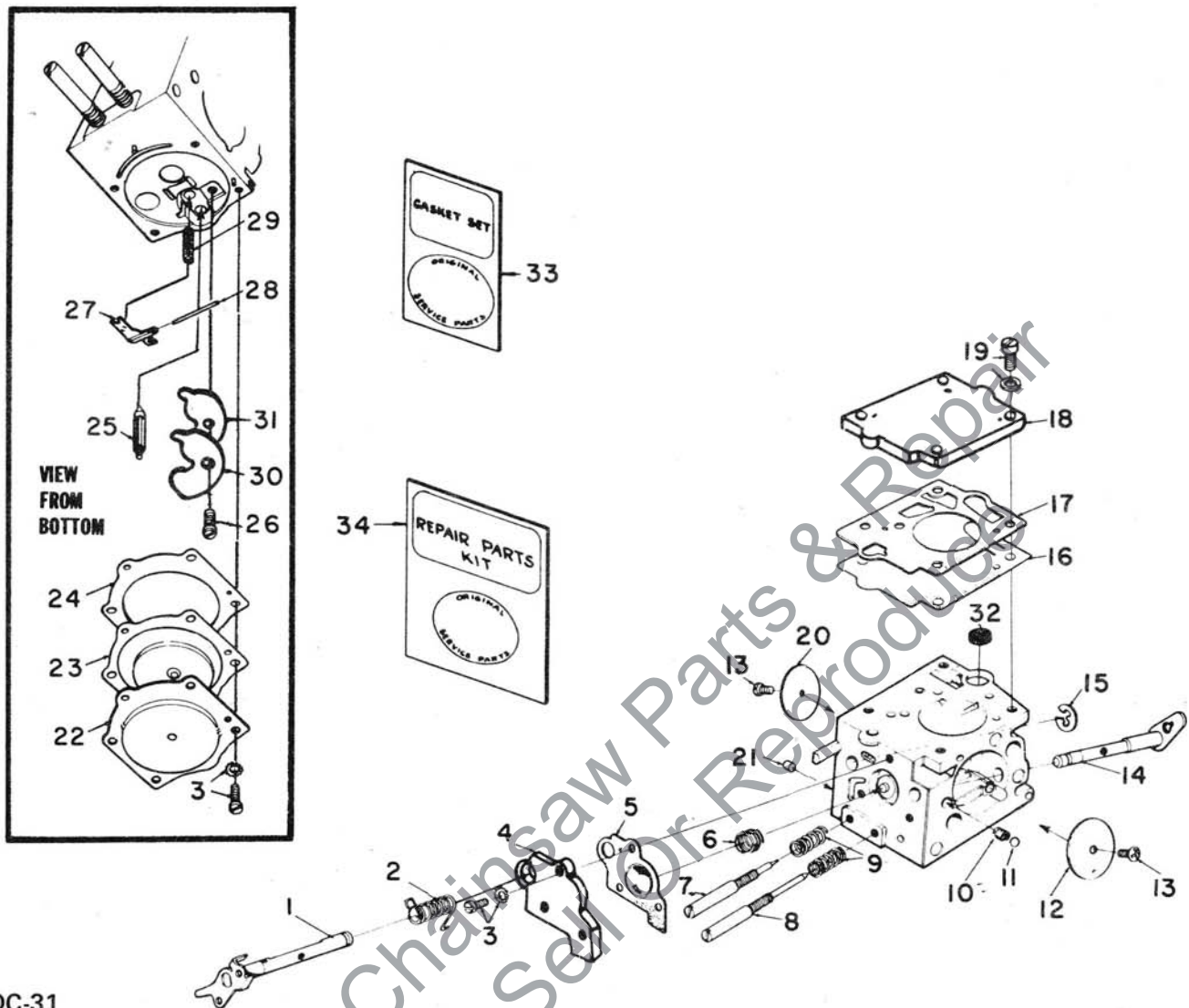

SDC-31

A-68402

No.	Description	Part No.	Qty.	No.	Description	Part No.	Qty.
1	THROTTLE SHAFT ASSEMBLY	64225	1	19	SCREW-fuel pump cover	64694	4
2	SPRING-throttle return	†67006	1	20	VALVE-throttle	67700	1
3	SCREW ASSEMBLY	64689	7	21	PLUG-limiting	64692	1
4	COVER-accelerator pump	67187	1	22	COVER-metering diaphragm	64224	1
5	DIAPHRAGM-accelerator pump	†67188	1	23	METERING DIAPHRAGM ASSEMBLY	†64235	1
6	SPRING-accelerator pump	†64240	1	24	GASKET-metering diaphragm	†64231	1
7	NEEDLE-idle	†64241	1	25	VALVE-inlet needle	†64229	1
8	NEEDLE-high speed	†64242	1	26	SCREW-metering lever pins	†64688	1
9	SPRING-needle adjusting	†64236	2	27	LEVER-metering	†64245	1
10	SPRING-choke friction	†64238	1	28	PIN-metering lever	†64244	1
11	BALL-choke friction	†60051	1	29	SPRING-metering lever	†64237	1
12	VALVE-choke	64228	1	*30	PLATE-circuit	†68780	1
13	SCREW-valve	†64693	2	*31	GASKET-circuit	†68781	1
14	CHOKE SHAFT ASSEMBLY	67109	1	32	SCREEN-fuel inlet	†64243	1
15	RING-throttle shaft retaining	64221	1	33	GASKET SET	†67019	1
16	DIAPHRAGM-fuel pump	†64233	1	34	REPAIR KIT	67197	1
17	GASKET-fuel pump	†67008	1		REPAIR KIT-check valve	65386	1
18	COVER-fuel pump	67002	1				

\* Denotes new parts

† Contained in gasket assortment

‡ Contained in repair kit index no. 34



# XL-123 XL-123-2

## Tools

A-23937-B	WRENCH-combination
22820-5	COLLAR-bearing installation (bearing to shaft)
22828	PLIERS-retaining ring
23136-1	SLEEVE-bearing & shaft installation
23528	WRENCH-socket screw (connecting rod)
23756	PLUG-needle bearing (connecting rod)
23759	SLEEVE-seal protection (back plate)
23846-2	ANVIL-roller bearing disassembly
A-23934	SPANNER-clutch
A-23949	TOOL-piston pin removal
A-23960	BRACKET-rotor removal
23972	SLEEVE-seal installation
24006-2	PLATE-shaft alignment
A-24051	JACKSCREW-(bearing to shaft to crankcase)
24054	PLUG-seal assembly (crankcase)
24055	PLUG-bearing & seal assembly (back plate)
A-24057	BEARING REMOVER-(back plate)
24076	SLEEVE-seal protecting (crankcase side)
A-24138	REAMER-compression release
24230	DRIVER-hand, pozidriv
24173	DRIVER-check valve installation
24304	BIT-pozidriv #2
23987	SHIM-plastic (magneto air gap)

## Accessories

A-68074	SPARK ARRESTER-(reed muffler)
65543-1	HEAT EXCHANGER
A-24267-A	KIT-starter rope
A-24450	KIT-guide bar plate
A-24273	KIT-ignition

## PAINT

22772	SPRAY CAN-black
23475	SPRAY CAN-red



# NUMERICAL

# XL-123 XL-123-2

# PARTS LIST

Part No.	Description	Qty.	Part No.	Description	Qty.	Part No.	Description	Qty.	Part No.	Description	Qty.
22772	Spray Can-black	1	63870	Spring-rewind	1	64688	Screw	1	67634	Boot	1
22820-5	Collar	1	63875	Ring	1	64689	Screw Assembly	7	67700	Valve-throttle	1
22828	Pliers	1	63877-A	Stud-shoulder	2	64692	Plug-limiting	1	A-67888-C	Muffler-reed	1
23136-1	Sleeve	1	63896-A	Rod-throttle	1	64693	Screw-valve	2	A-68040	Cover-fuel tank	1
23475	Spray Can-red	1	63905	Washer	2	64694	Screw	4	*A-68056	Bracket	1
23528	Wrench	1	63910	Plate-"On-Off"	1	A-64722	Bumper-spiked	1	A-68061-A	Plunger	1
23756	Plug	1	A-63919	Line-oil	1	A-64741	Filter-oil	1	A-68074	Spark Arrester	1
23759	Sleeve	1	A-63920	Filter-fuel	1	64813	Ring	1			
23846-2	Anvil	1	A-63928	Cover	1	64862	Grommet	2	A-68120	Cover-oil tank	1
A-23934	Spanner-clutch	1	A-63936	Fitting	1	64904-1	Plate-clutch	1	*A-68142	Plate-back	1
A-23937-B	Wrench	1	A-63938	Switch	1	A-64908	Sprocket & Drum	1	OM68210	Sprocket	1
A-23949	Tool	1	A-63939	Lead	1	64948	Lock-spring	1			
A-23960	Bracket	1	A-63947	Line-oil	1	65082	Nut-plunger	1	*68338	Screw-shoulder	2
23972	Sleeve	1	A-63952-B	Pulley & Cup	1	65122	Grommet	1	*68339	Screw-shoulder	1
23987	Shim-plastic	1	A-63955-A	Filter Element	1	65133	"O" Ring	1	*A-68341	Bracket	1
24006-2	Plate	1	63990	Race	1	A-65283-B	Cap-fuel filler	1	*68394	Pad-handle bar	1
A-24051	Jackscrew	1	64021	Screw	2	A-65284-A	Cap-oil (vented)	1	*A-68438	Piston & Pin	1
24054	Plug	1	64083-1	Filter-felt	1	65321	Screw	5	*A-68439-A	Crankcase & Tank	1
24055	Plug	1	64085	Screw-cover	2	65364-A	Gasket-fuel tank	1	*A-68465	Sprocket & Drum	1
A-24057	Bearing Remover	1	64086	Condenser	2	65365	Pin-dowel	2	*68466	Grip	1
24076	Sleeve	1	A-64087	Point	1	65375-1	Spring	2	*68467	Grip	1
A-24138	Reamer	1	64088	Block	1	65386	Repair Kit	1	*A-68483	Handle-throttle	1
24173	Driver	1	64089	Retainer-felt	1	65491	Screen	1			
24230	Driver	1	64090	Screw-terminal	2	65522-A	Screw	1			
A-24267-A	Kit-starter rope	1	64091	Coil-ignition	1	65543-1	Heat Exchanger	1	*A-68498-A	Rod-connecting	1
A-24273	Kit-ignition	1	64102-A	Screw-cam	1	65586	Plate	1	*68730	Crankshaft	1
24304	Bit-pozidriv #2	1	64124	Bearing-cage	1	65592-A	Pin	1	*68780	Plate-circuit	1
A-24450	Kit-guide bar plate	1	64144	Decal	1	65670	Plate-handle bar	1	*68781	Gasket-circuit	1
25038	Gasket	1				65696	Fitting-straight	1	71430	Pin-dowel	2
28008	Clip-post	1	64155-A	Grip-rope	1	65768-1	Pin-bar	1	72084-A	Nut	1
28028	Washer-post	1	64182	Washer	1	*A-65795-1A	Cylinder	1	72489	Insert-taplock	5
31734	Connector-elbow	1	64221	Ring	1	65829	Gasket-cylinder	1	75078	Key-woodruff	1
A-33055	Terminal	1	64224	Cover	1	65842	Spring-clutch	3	75120	Ring-retaining	1
54422	Core-coil	1	64225	Shaft	1	65889	Rivet-accordion	4	76421	Screw-clamp	2
54423	Clip-coil	1	64228	Valve-choke	1	A-65948	Valve-check	1	FASTENING PARTS		
55411	Screw-clamp	2	64229	Valve-needle	1	65949-2	Clamp-oil	1	80541	8-32 x 1/2	2
55871	Stud-cylinder	3	64231	Gasket	1	65985	Race-inner	1	80560	8-32 x 1/2	2
58308-A	Seal	1	64233	Diaphragm	1	A-65988	Drum & Hub	1	80568	8-32 x 7/8	3
58319-A	Ring-retaining	2	64235	Diaphragm	1	67000-1	Rod-choke	1	80571	6-32 x 3/8	4
58338	Gasket-valve	1	64236	Spring-needle	2	67002	Cover	1	80572	10-32 x 5/8	2
58339	Cap-valve	1	64237	Spring	1	67006	Spring	1			
58406	"O" Ring	1	64238	Spring	1	67008	Gasket	1	80648	10-32 x 1/2	5
58688-A	Seal	1	64240	Spring	1	67019	Gasket Set	1	80676	12-24 x 5/8	6
*58785	"O" Ring	1	64241	Needle-idle	1	A-67023	Pump	1	80821	12-24 x 1/2	4
58858	Grommet	1	64242	Needle	1	A-67079	Line-oil	1	80891	12-24 x 7/8	1
58966	Lead	1	64243	Screen	1	67109	Choke Shaft	1	80919	4-40 x 1/4	2
59074	"O" Ring	2	64244	Pin	1	67177	Bushing	1			
59436	Piston Ring	2	64245	Lever	1	67185	Washer	1	81065-2	Nut-1/4-28	4
59571	Plug-pipe	1	64252-A	Seat	1	67187	Cover	1	81068	Nut-12-24	2
59678-B	Reed-valve	4	64253-A	Retainer	1	67188	Diaphragm	1	81117	Nut-5/16-24	1
59704	Screw	2	64266	Gasket	1	67191	Stud-drive	4	81126	Nut-6-32	4
59736	Gasket	1	64267	Gasket	1	A-67192-A	Housing-fan	1	81196	Nut-5/16-18	2
60051	Ball-choke	1	A-64293	Filter-oil	1	67193	Bolt-guide bar	2	81211	Nut-10-32	1
63113	Screw-set	1	64301	Retainer-lead	1	67197	Repair Kit	1	82126	10-32 x 1	1
63183-4	Cover-air filter	1	64333	Bearing	2	67222	Ring-air flow	1	82151	8-32 x 15/16	2
63212-A	Trigger-throttle	1	64356	Line	1	67265	Gasket-oil tank	1	82152	8-32 x 1-1/4	1
63228	Worm-oil pump	1	64374	Bushing	1	67299	Plate-(outer)	1	82153	8-32 x 1-5/8	3
63290	Washer-felt	1	64393	Seal-felt	1	67300	Plate-(inner)	1	82154	8-32 x 1-7/8	3
63544	Line-fuel	1	64442	Pawl-starter	2	67386	Button	1	82155	8-32 x 2-3/16	7
63547-S	Spark Plug	1	64474	Grommet	2				82156	8-32 x 3/4	3
*63599-5	Cover	1	64569-3	Shoe-clutch	3	67395	Bearing-roller	1	82173	8-32 x 1	1
63606	Washer-retaining	1	64610	Pad-bracket	1	67408	Bearing-needle	1	82174	8-32 x 1-1/4	2
63637	Rotor	1	64618	Shield	1				82179	10-32 x 1-7/8	2
63671	Cover-clutch	1	A-64620-1	Cover	1				83002	Washer-5/16	1
63713	Shield-spring	1	64646	Bushing	1				83009	Washer-1/4	4
63714	Shield-spring	1	64653	Spring	1	A-67482	Pin	1	83046	Washer-#10	2
63718	Valve-vent	1	64654-B	Lever	1	A-67502-A	Manifold-intake	1	83056	Washer-#12	4
63865-S	Bearing-ball	1	64655-2	Clamp-lever	1				84018	Washer-#6	2
63868	Stud-cylinder	1	A-64656-2	Pivot Pin	1	67506-2	Stop-handle bar	1	84032	Washer-5/16	2
63869	Rope-starter	1	64677	Spring	1	A-67627	Nut	1	84065-1	Washer-5/16	1
						67631	Gasket	1	85061	Rivet-oval head	2
									86301	Pin-cotter	1
									86324	Pin-cotter	1

\* Denotes new parts

## ADDENDUM PARTS LIST FOR KL-123 & XL-123-2

Part No.	Description	Qty.
63860	Washer, thrust	1
A-64130-2	Body, muffler	1
64133-A	Screw-shoulder	2
65175-A	Screw	1
A-68402	Carburetor	1
68472	Baffle, muffler	1
68481	Screw-shoulder	2
68751	Retainer	1
68837	Insert	1
A-68932-1	Guard-anti kickback	1
68934-1	Bushing	1
68935	Washer	1
68939-1	Washer-flat	1
68940-1	Washer-flat	1
A-68951-1	Cap, muffler	1
68961	Gasket	1
A-68995	Bracket, handle bar	1
A-69033-1	Handle bar	1
A-69050	Roller, needle	1
69228-1	Cap-muffler	1
69230-1	Baffle-muffler	1
A-69231-1	Body-muffler	1
80821	Screw-hex hd (12-24x1/2)	1
81222	Nut (#12-24)	1
82223	Screw-flat hd (#12-24x1-1/2)	1
84006-1	Washer-flat	2
84099	Washer-flat	1

Leon's Chainsaw Parts & Repair  
Do Not Sell Or Reproduce



Leon's Chainsaw Parts & Repair  
Do Not Sell Or Reproduce



• textron  
DIVISION