

PRICE .25

XL-101
XL-102
XL-103
XL-104

PARTS LIST

PART NO. 24106-A Supersedes 24106
Rev. 1 968
Printed in U.S.A.

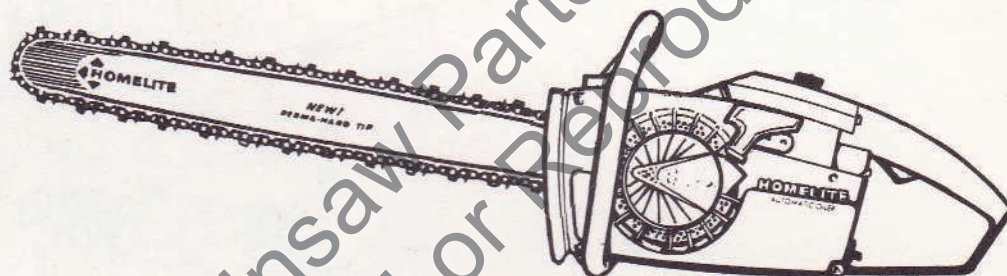

HOMELITE®

CHAIN SAW



HOMELITE XL CHAIN SAWS

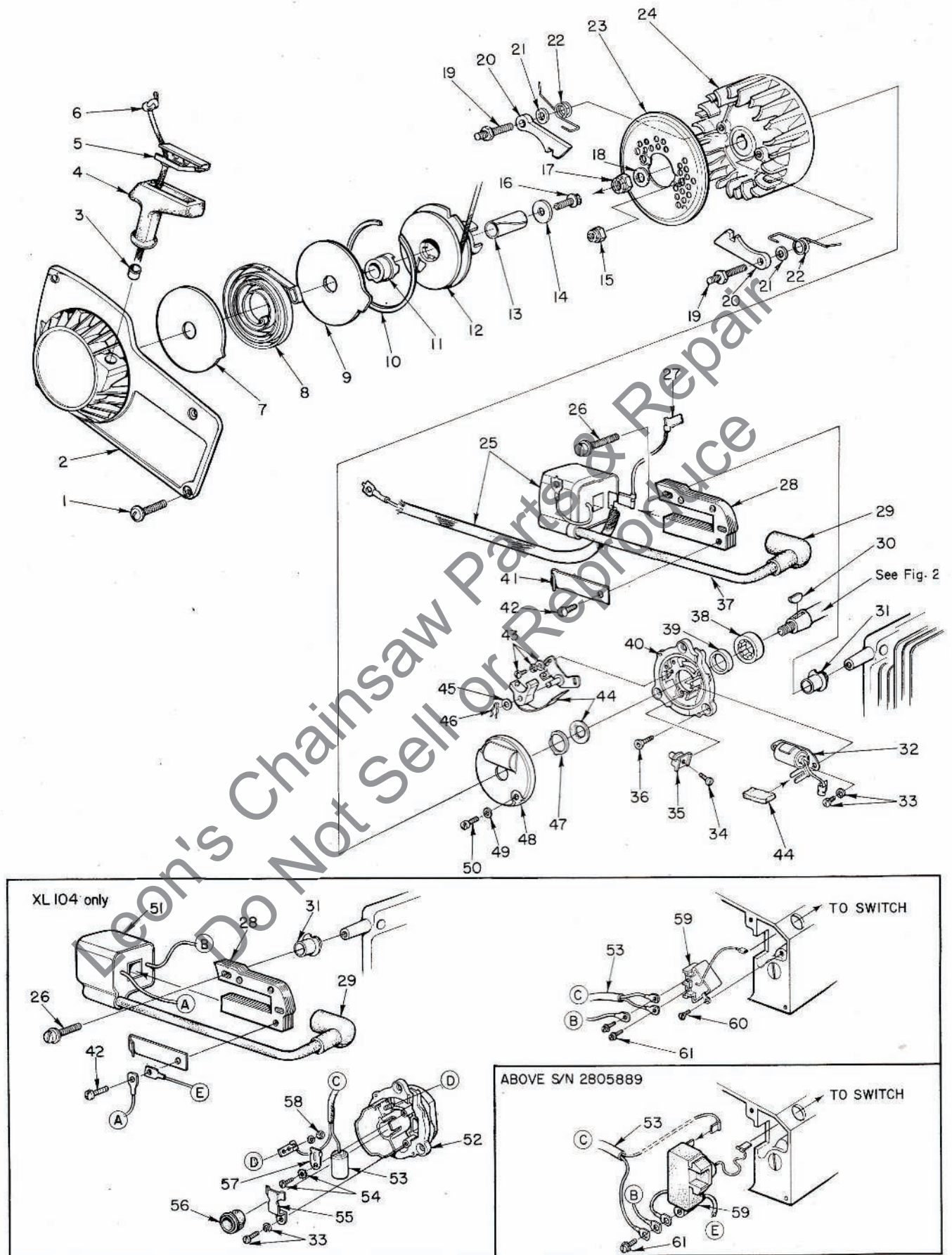

FIGURE 1

ALWAYS FURNISH MODEL AND SERIAL NUMBER WHEN ORDERING PARTS.

HOMELITE XL CHAIN SAWS

No.	Description	Part No.	XL-101	XL-102	XL-103	XL-104	Qty.
1	SCREW - pan hd., 8-32 x 1/2	80560	x	x	x	x	4
2	HOUSING - fan	A-64191-1	x	x	x	x	1
3	Includes: BUSHING - starter rope	59313	x	x	x	x	1
4	GRIP - starting rope	64155	x	x	x	x	1
5	INSERT - rope retaining	64154	x	x	x	x	1
6	ROPE - starter	63869	x	x	x	x	1
7	SHIELD - spring (inner)	63713	x	x	x	x	1
8	SPRING - rewind	63870	x	x	x	x	1
9	SHIELD - spring (outer)	63714	x	x	x	x	1
10	RING - shield retaining	63875	x	x	x	x	1
*11	LOCK - spring	64948	x	x	x	x	1
*12	PULLEY & CUP ASSEMBLY - starter	A-63952-A	x	x	x	x	1
13	BUSHING - starter post	64374	x	x	x	x	1
14	WASHER - retaining	63606	x	x	x	x	1
15	NUT - flexloc, #10-32	81109-2	x	x	x	x	2
16	SCREW - hex hd., 10-32 x 1/2	80648	x	x	x	x	1
17	NUT - lock, 5/16-24	81112	x	x	x	x	1
18	WASHER - flat, 5/16	84065-1	x	x	x	x	1
19	STUD - shoulder	63877	x	x	x	x	2
20	PAWL - starter	64442	x	x	x	x	2
21	WASHER - flat	58851	x	x	x	x	2
22	SPRING - starter pawl	58758-2	x	x	x	x	2
23	SCREEN - rotor	63219	x	x	x	x	1
24	ROTOR - magneto	63637	x	x	x	x	1
	ROTOR - magneto	† 64437				x	1
*	ROTOR - magneto	65909				x	1
25	COIL - ignition	64091	x	x	x	x	1
26	SCREW - coil core	64021	x	x	x	x	2
27	LEAD - ground to switch	A-63939	x	x	x	x	1
28	CORE - coil	54422	x	x	x	x	1
29	TERMINAL - spark plug	A-33055	x	x	x	x	1
30	KEY	75078	x	x	x	x	1
31	RETAINER - lead	64301	x	x	x	x	1
32	CONDENSER & CLAMP	64086	x	x	x	x	1
33	SCREW - condenser clamp	55411	x	x	x		2
	SCREW - condenser clamp	55411				x	1
34	SCREW - terminal	64090	x	x	x		1
35	BLOCK - terminal	64088	x	x	x		1
*36	SCREW - flat hd., 12-24 x 5/8	65321	x	x	x	x	3
37	LEAD - high tension	59966	x	x	x	x	1
38	BEARING - roller	63867	x	x	x	x	1
39	SEAL	58688-A	x	x	x	x	1
*40	BACK PLATE	63624-1A	x	x	x		1
41	CLIP - coil retaining	54423	x	x	x	x	1
42	SCREW - coil retaining clip	58872	x	x	x	x	1
43	SCREW - breaker clamp	76421	x	x	x		2
44	POINTS - set w/felt	A-64087	x	x	x		1
45	Includes: WASHER - post	28028	x	x	x		1
46	CLIP - post	28008	x	x	x		1
47	FELT RETAINER	64089	x	x	x		1
48	COVER ASSEMBLY - breaker box	A-63928	x	x	x		1
49	WASHER - flat, #6	84018	x	x	x		2
50	SCREW - cover	64085	x	x	x		2
51	COIL - ignition	64435				x	1
52	BACK PLATE & CORE	† A-64426				x	1
*	BACK PLATE & CORE	A-65908				x	1
53	CONDENSER & LEAD	† 64427				x	1
*	CONDENSER & LEAD	65913				x	1
54	SCREW - lead hold down plate	64432				x	1
55	CLAMP - condenser	63627				x	1
56	CAP - dust	64423				x	1
57	PLATE - lead hold down	64431				x	1
58	LOCKWASHER - coil lead clamp nut	64430				x	1
59	SWITCH BOX	† A-64440				x	1
*	SWITCH BOX	65911				x	1
60	SCREW - flat hd., 6-32 x 3/8	† 80451				x	1
61	SCREW GROUP	† 64734				x	2
*	SCREW GROUP	65912				x	1

† Below serial number 2805889

* Denotes new part

HOMELITE XL CHAIN SAWS

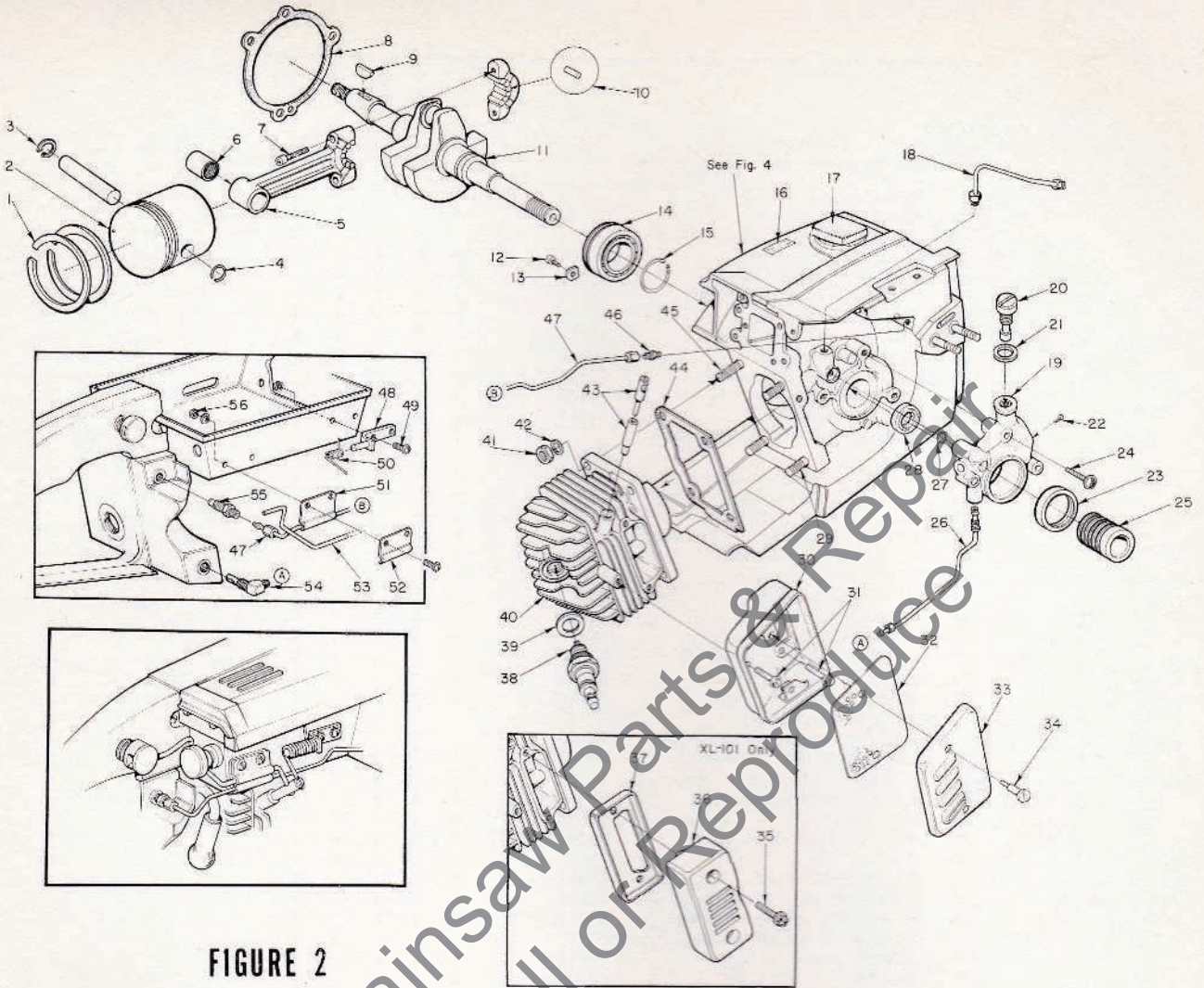

FIGURE 2

No.	Description	Part No.	Model				Qty.	No.	Description	Part No.	Model				Qty.
			XL-101	XL-102	XL-103	XL-104					XL-101	XL-102	XL-103	XL-104	
1	PISTON RING	59486	x	x	x	x	2	29	STUD - cylinder (short)	55871	x	x	x	x	3
	PISTON RING	58877		x			2	30	BODY - muffler	A-64130		x	x	x	1
2	PISTON & PIN	A-59468-B	x	x	x	x	1	31	SCREW - hex hd., 12-24x1/2	80821		x	x	x	3
	PISTON & PIN	A-58903-B		x			1	32	BAFFLE - muffler	64126		x	x	x	1
3	Includes: RING - retaining	76120	x	x	x	x	1	33	CAP - muffler	64125		x	x	x	1
4	Includes: RING - retaining	64813	x	x	x	x	1	34	SCREW - shoulder	64133-A		x	x	x	2
5	ROD - connecting	A-63790	x	x	x	x	1	35	SCREW - hex hd., 12-24x1-1/4	80994	x				2
6	Includes: BEARING - needle	58724	x	x	x	x	1	36	BODY - muffler	64131-1	x				1
7	Includes: SCREW	80889	x	x	x	x	2	37	BASE - muffler	64132	x				1
8	GASKET - crankcase	63361	x	x	x	x	1	38	SPARK PLUG	63547-5	x	x	x	x	1
9	KEY	75078	x	x	x	x	1	39	Includes: GASKET	25038	x	x	x	x	1
10	ROLLER - needle (set of 31)	A-63797-A	x	x	x	x	1	*40	CYLINDER - See NOTE 1	A-64542-2		x	x	x	1
11	CRANKSHAFT	63204-1		x	x	x	1	*	CYLINDER - See NOTE 1	63165-3	x				1
	CRANKSHAFT	63204-2	x				1	41	NUT - hex, 1/4-28	81065-2	x	x	x	x	4
12	SCREW - bearing retainer	59704	x	x	x	x	2	42	WASHER - lock, 1/4	83009	x	x	x	x	4
13	WASHER - special	63905	x	x	x	x	2	*43	PIN - compression relief - See NOTE 2	A-65767		x	x	x	1
14	BEARING - ball	63865-S	x	x	x	x	1	*44	GASKET - cylinder - See NOTE 1	65829	x	x	x	x	1
15	RING - retaining	58319-A	x	x	x	x	1	45	STUD - cylinder (long)	63868	x	x	x	x	1
16	DECAL	64144	x	x	x	x	1	46	FITTING - straight	31733-1	x	x	x	x	1
17	CAP - fuel filler	A-64375	x	x	x	x	1	*47	LINE - oil (manual) - See NOTE 3	A-63948-A	x	x	x	x	1
18	LINE - oil (auto. upper)	A-63919		x	x	x	1	48	PIVOT PIN & BRACKET ASSEMBLY	A-64656-2		x	x	x	1
*19	PUMP - automatic oil	A-67023		x	x	x	1	49	SCREW - pan hd., 6-32 x 3/8	80571		x	x	x	4
20	Includes: SCREW - cam	64102-A		x	x	x	1	50	SPRING - relief valve	64653		x	x	x	1
21	Includes: GASKET	59736		x	x	x	1	*51	CLAMP - oil	64647-2		x	x	x	1
22	Includes: SCREW - pan hd., 4-40 x 1/4	80919			x	x	2	52	CLAMP - lever	64655-2		x	x	x	1
23	SEAL - felt	64393		x	x	x	1	*53	LEVER - relief valve	64654-B		x	x	x	1
24	SCREW - pan hd., 8-32 x 7/8	80568		x	x	x	3	54	FILTER - oil	A-64741			x	x	1
25	WORM - oil pump	63228		x	x	x	1	*55	VALVE - check	A-59456-1	x	x	x	x	1
26	LINE - oil (auto. lower)	A-63947		x	x	x	1	56	NUT - flexlock, 6-32	81126		x	x	x	4
27	"O" RING	90872		x	x	x	1								
28	SEAL	58308-A	x	x	x	x	1								

* Denotes new part

HOMELITE XL CHAIN SAWS

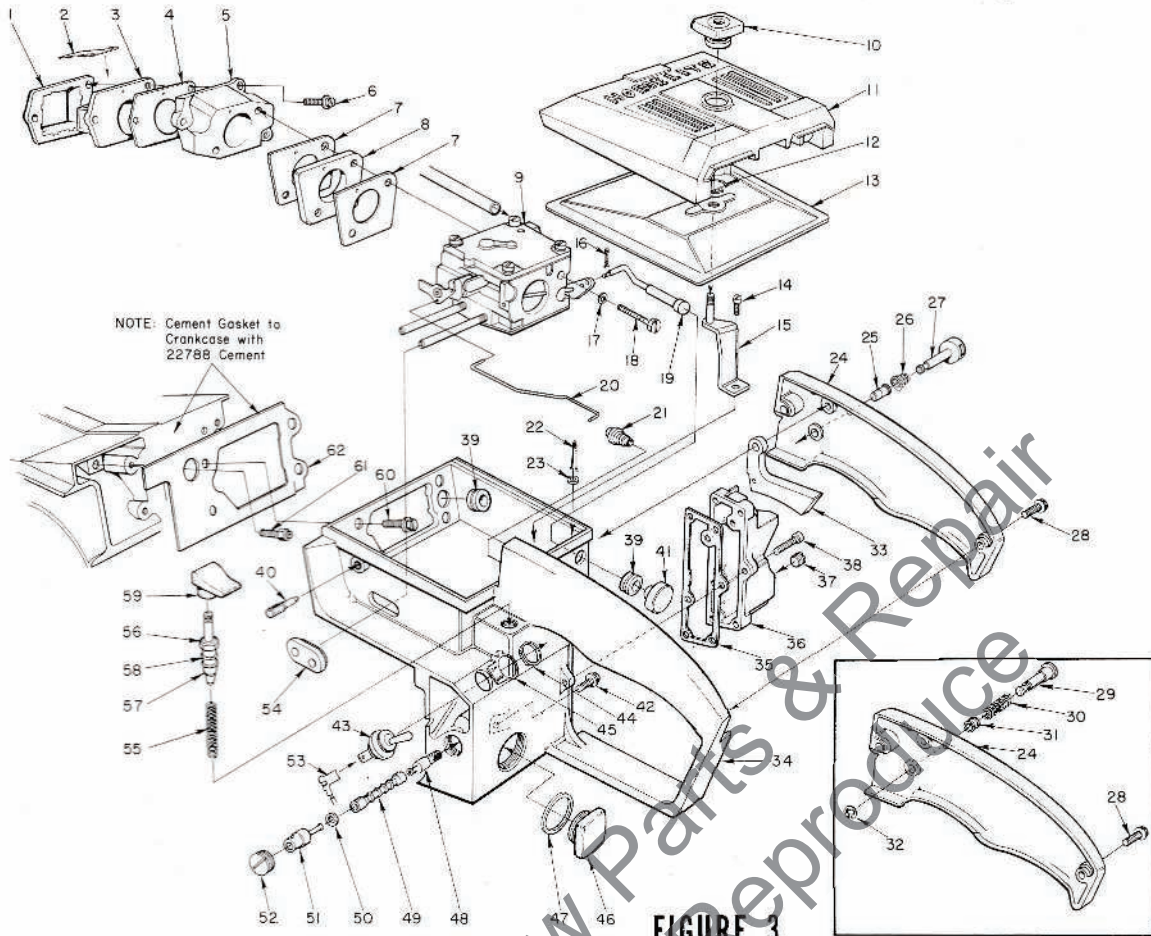

FIGURE 3

No.	Description	Part No.	XL-101	XL-102	XL-103	XL-104	Qty.	No.	Description	Part No.	XL-101	XL-102	XL-103	XL-104	Qty.
1	RETAINER - reed valve	64253	x	x	x	x	1	*	HANDLE - throttle - See NOTE 4	A-65921				x	1
2	REED - valve	59678-A	x	x	x	x	4	*35	Includes: GASKET - oil tank	65394	x	x	x	x	1
3	SEAT - reed valve	64252	x	x	x	x	1	*36	COVER - oil tank - See NOTE 4	A-65584	x	x	x	x	1
4	GASKET - reed valve seat	64266	x	x	x	x	1	37	Includes: PLUG - pipe	59571	x	x	x	x	1
5	MANIFOLD - intake	64265-1A	x	x	x	x	1	*38	SCREW - fil hd., 8-32 x 3/4	82156	x	x	x	x	6
* 6	SCREW - shoulder	64349-A	x	x	x	x	3	39	GROMMET - See NOTE 4	64862	x	x	x	x	2
7	GASKET - carburetor	64118-1	x	x	x	x	2	*40	SCREW - idle adj. - See NOTE 4	65522	x	x	x	x	1
8	SPACER - carburetor	64117-1	x	x	x	x	1	41	BUTTON - choke	57289-1	x	x	x	x	1
9	CARBURETOR	A-64196	x	x	x	x	1	42	SCREW - hex hd., 12-24 x 7/8	80891	x	x	x	x	1
10	NUT - cover mounting	A-64268	x	x	x	x	1	43	SWITCH	A-63938	x	x	x	x	1
11	COVER - air filter	63153-2	x	x	x	x	1	44	Includes: NUT	72084-A1	x	x	x	x	1
12	RING - retaining	58319-A	x	x	x	x	1	45	PLATE - "On - Off"	63910	x	x	x	x	1
13	FILTER ELEMENT - air	A-63955-A	x	x	x	x	1	46	CAP - oil, vented	A-64766	x	x	x	x	1
14	SCREW - hex hd., 12-24 x 1/2	80821	x	x	x	x	1	47	Includes: "O" RING VALVE - vent (not shown)	65323	x	x	x	x	1
15	BRACKET - air filter cover	A-63576	x	x	x	x	1	48	FILTER - oil (manual)	63718	x	x	x	x	1
16	PIN - cotter	86324	x	x	x	x	1	49	LINE - flexible oil	A-64293	x	x	x	x	1
17	WASHER - lock #10	83046	x	x	x	x	2	50	GASKET	59736	x	x	x	x	1
18	SCREW - hex hd., 10-32 x 2	80965	x	x	x	x	2	51	FITTING - check valve	A-63936	x	x	x	x	1
19	ROD - Choke - See NOTE 4	A-63942-1	x	x	x	x	1	52	SCREW - set	63113	x	x	x	x	1
20	ROD - throttle	63896-1	x	x	x	x	1	53	LEAD - ground	A-63939	x	x	x	x	1
21	BOOT - throttle rod	58348	x	x	x	x	1	54	GROMMET - "Hi-Lo"	58858	x	x	x	x	1
22	PIN - cotter	86301	x	x	x	x	1	55	SPRING - plunger	59293	x	x	x	x	1
23	WASHER - felt	63290	x	x	x	x	1	56	PLUNGER	A-57834-15	x	x	x	x	1
* 24	COVER - throttle handle	63197-2A	x	x	x	x	1	57	Includes: "O" RING	74388	x	x	x	x	1
25	BUSHING - throttle lock	64646	x	x	x	x	1	58	"O" RING	59074	x	x	x	x	1
26	SPRING - throttle lock	64677	x	x	x	x	1	59	BUTTON - oil pump	63622	x	x	x	x	1
* 27	PIN - throttle lock	65592	x	x	x	x	1	60	SCREW - hex hd., 12-24 x 5/8	80676	x	x	x	x	4
28	SCREW - pan hd., 8-32 x 1/2	80560	x	x	x	x	2	61	VENT - fuel tank	A-64311	x	x	x	x	1
29	PIN - throttle lock	58924-1	x	x	x	x	1	62	GASKET - throttle handle	64267	x	x	x	x	1
30	SPRING - throttle lock	58405	x				1								
31	BUSHING - throttle lock	59064	x				1								
32	RING - retaining	58409	x				1								
33	TRIGGER - throttle	63212-A	x	x	x	x	1								
* 34	HANDLE - throttle - See NOTE 4	A-65437	x				1								
* 35	HANDLE - throttle - See NOTE 4	A-65439		x	x		1								
* 36	HANDLE - throttle - See NOTE 4	A-65441				x	1								

† Below serial number 2805889

* Denotes new part.

ALWAYS FURNISH MODEL AND SERIAL NUMBER WHEN ORDERING PARTS.

HOMELITE XL CHAIN SAWS

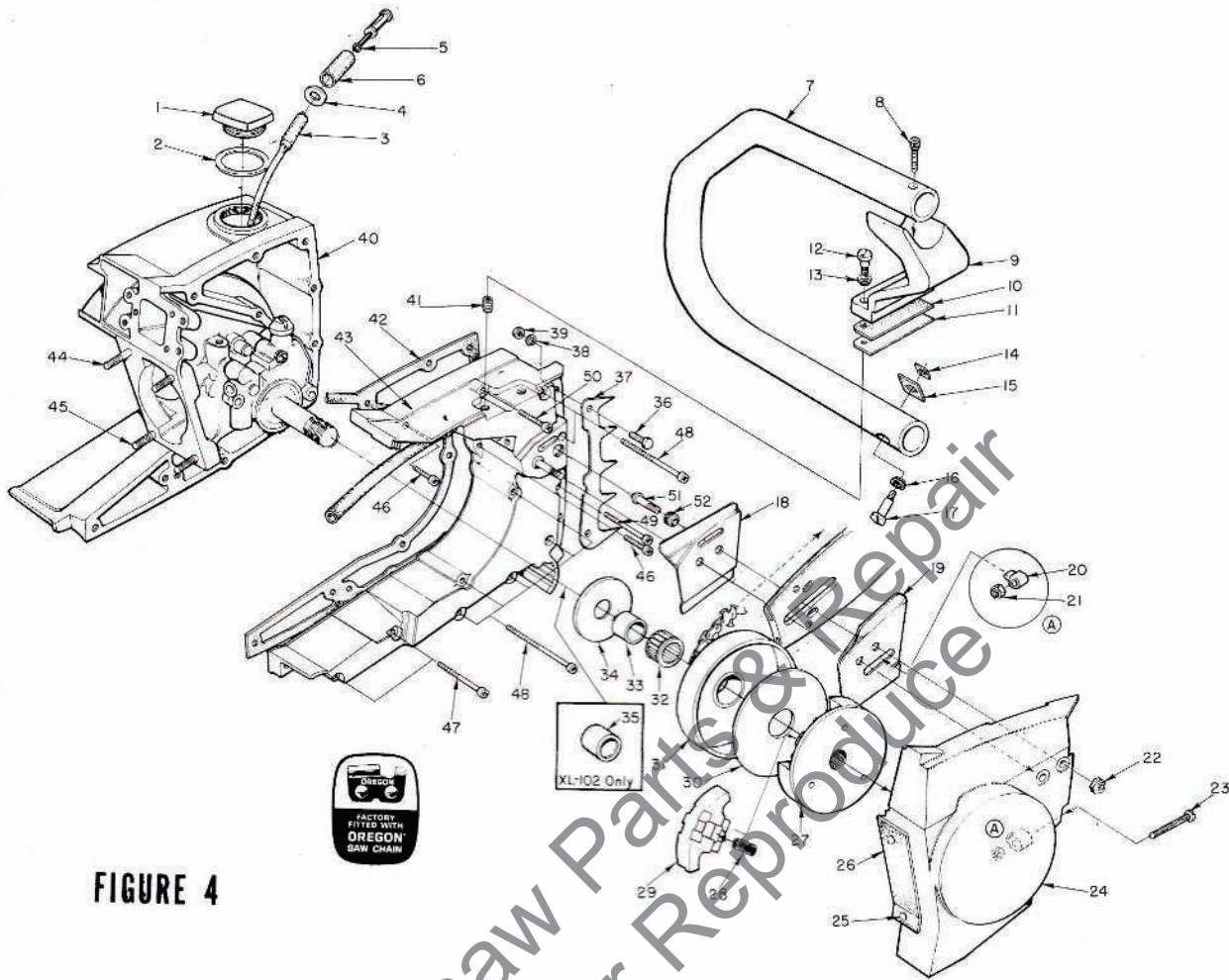
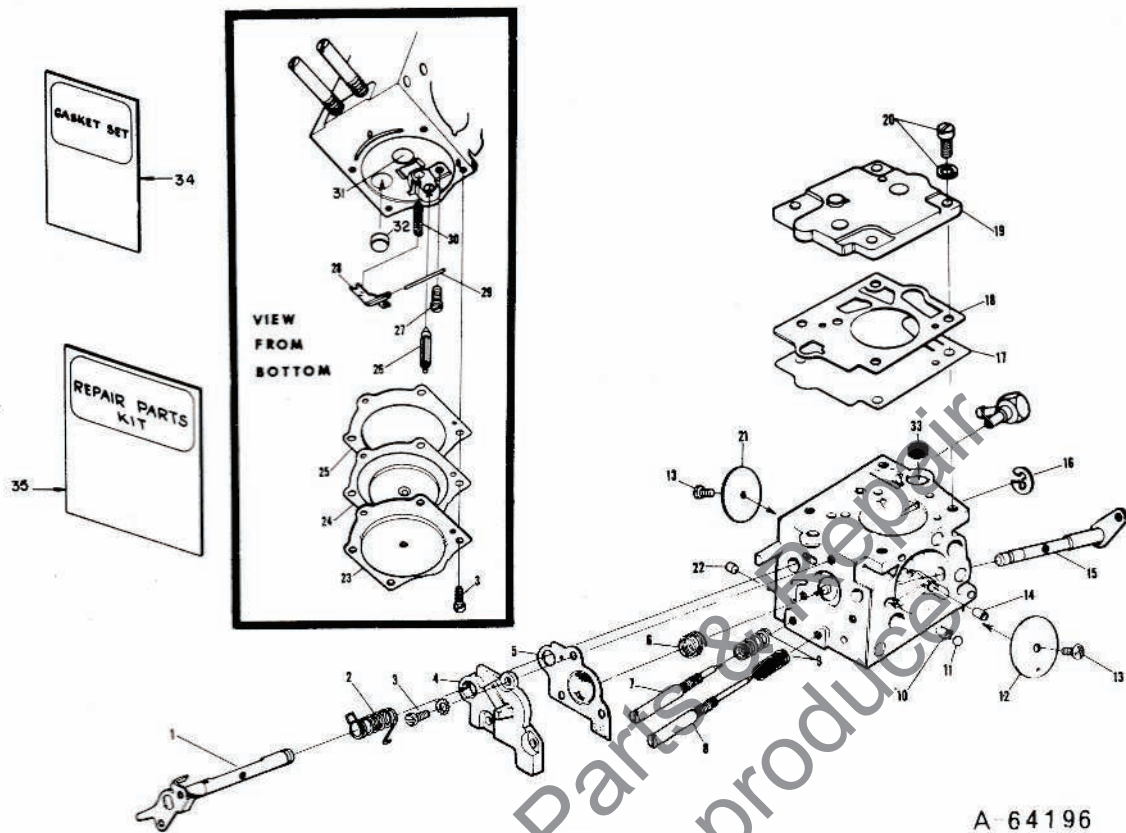

FIGURE 4

No.	Description	Part No.	XL-101	XL-102	XL-103	XL-104	Qty.	No.	Description	Part No.	XL-101	XL-102	XL-103	XL-104	Qty.
1	CAP - fuel filler	A-64375	x	x	x	x	1	* 33	RACE - inner - see NOTE 7	65985	x	x	x	x	1
2	Includes: GASKET	64659	x	x	x	x	1	* 34	WASHER - thrust - See NOTE 7	58833-1	x	x	x	x	1
3	LINE - fuel	63544	x	x	x	x	1	35	SPACER	64372	x	x	x	x	1
4	WASHER	64182	x	x	x	x	1	36	SCREW - hex hd., 12-24 x 5/8	80676	x	x	x	x	2
5	FILTER - fuel	A-63920	x	x	x	x	1	37	BUMPER - spiked (optional)	64067	x	x	x	x	1
6	Includes: FILTER - felt	64083	x	x	x	x	1	38	WASHER - lock #12	83056	x	x	x	x	2
* 7	HANDLE BAR - See NOTE 5	A-65568-2	x	x	x	x	1	39	NUT - hex. 12-24	81068	x	x	x	x	2
* 8	HANDLE BAR - See NOTE 5	A-65365-1	x	x	x	x	1	* 40	CRANKCASE & TANK - See NOTE 5	A-64790-C	x	x	x	x	1
9	SCREW - soc. hd. cap. 10-32 x 1	82126	x	x	x	x	1	* 41	CRANKCASE & TANK - See NOTE 5	A-64797-C	x	x	x	x	1
* 9	BRACKET - handle bar	A-05666-1	x	x	x	x	1	Inc: PIN - dowel (not shown)	71430	x	x	x	x	2	
10	PAD - bracket	64670	x	x	x	x	1	PIN - dowel (not shown)	65365	x	x	x	x	2	
* 11	PLATE - handle bar bracket	65586	x	x	x	x	1	* 42	SEAL (See Fig.2, Index #28)	58308-A	x	x	x	x	1
12	SCREW - shoulder	64614-A	x	x	x	x	2	43	INSERT - taplock	72489	x	x	x	x	2
13	GROMMET - handle bar	64474	x	x	x	x	2	* 44	GASKET - fuel tank	65364	x	x	x	x	1
* 14	PLATE - handle bar	65670	x	x	x	x	1	* 45	COVER - fuel tank	A-64786-1A	x	x	x	x	1
* 15	PAD - handle bar	65559	x	x	x	x	1	Inc: INSERT - taplock (not shown)	72489	x	x	x	x	3	
16	GROMMET - handle bar	64473	x	x	x	x	1	* 46	COVER - fuel tank	A-65576-A	x	x	x	x	1
* 17	SCREW - shoulder	64754	x	x	x	x	1	Inc: (not shown)	GASKET - check valve	58338	x	x	x	x	1
* 18	PLATE - guide bar (inner)	63638-B	x	x	x	x	1	47	CAP - check valve	58339	x	x	x	x	1
19	PLATE - guide bar (outer)	63639-A	x	x	x	x	1	* 48	INSERT - taplock	72489	x	x	x	x	3
* 20	PIN - bar adjusting	63768-1	x	x	x	x	1	* 49	STUD - cylinder	63868	x	x	x	x	3
21	NUT - lock, 10-32	81211	x	x	x	x	1	50	STUD - cylinder	55871	x	x	x	x	3
22	NUT - hex, 5/16-18	81196	x	x	x	x	2	* 51	SCREW - fil., 8-32 x 15/16	82151	x	x	x	x	2
* 23	SCREW - guide bar adjusting	65944	x	x	x	x	1	* 52	SCREW - fil., 8-32 x 1-7/8	82154	x	x	x	x	2
24	COVER - drivecase	A-64820-1	x	x	x	x	1	* 48	SCREW - fil., 8-32 x 1-5/8	82153	x	x	x	x	7
25	Includes: RIVET - oval head	85061	x	x	x	x	2	*	SCREW - fil., 8-32 x 2-3/16	82155	x	x	x	x	7
26	SHIELD - sawdust	64618	x	x	x	x	1	* 49	SCREW - fil., 8-32 x 1-1/4	82152	x	x	x	x	1
27	PLATE - clutch - See NOTE 6	64904-1	x	x	x	x	1	*	SCREW - fil., 8-32 x 1-7/8	82154	x	x	x	x	1
	PLATE - clutch	63669-1	x	x	x	x	1	*	SCREW - fil., 8-32 x 5/8	82146	x	x	x	x	1
* 28	SPRING - clutch	65842	x	x	x	x	3	*	SCREW - fil., 8-32 x 1-1/4	82152	x	x	x	x	1
	SPRING - clutch	64065	x	x	x	x	3	51	STUD - guide bar	63861	x	x	x	x	2
* 29	SHOE - clutch - See NOTE 6	64569-3	x	x	x	x	3	52	INSERT - threaded	59896-A	x	x	x	x	2
	SHOE - clutch	63670	x	x	x	x	3								
30	COVER - clutch	63671	x	x	x	x	1								
31	HUB & DRUM ASSEMBLY														
*	See NOTE 6 & 7	A-65988	x	x	x	x	1								
*	See NOTE 7	A-05987	x	x	x	x	1								
	SPROCKET - 3/8" pitch, 7 tooth	OMG#210	x	x	x	x	1								
32	BEARING - cage - See NOTE 7	64124	x	x	x	x	1								

* Denotes new parts.

HOMELITE XL CHAIN SAWS



MODEL - WALBRO SDC-1

A-64196

No.	Part No.	Description	Qty.	No.	Part No.	Description	Qty.
1	64225	THROTTLE SHAFT ASSEMBLY	1	19	64223	COVER, fuel pump	1
2	64239 †	SPRING, throttle return	1	20	64694	SCREW, fuel pump cover	4
3	64689	SCREW ASSEMBLY	7	21	64226	VALVE, throttle	1
4	64222	COVER, accelerator pump	1	22	64692	PLUG, limiting	1
5	64234 †	DIAPHRAGM, accelerator pump	1	23	64224	COVER	1
6	64240 †	SPRING, accelerator pump	1	24	64235 †	METERING DIAPHRAGM ASSEMBLY	1
7	64241 †	NEEDLE, idle	1	25	64231 †	GASKET, metering diaphragm	1
8	64242 †	NEEDLE, high speed	1	26	64229	VALVE, inlet needle	1
9	64236 †	SPRING, needle adjusting	2	27	64688 †	SCREW, metering lever pin	1
10	64238	SPRING, choke friction	1	28	64245 †	LEVER, metering	1
11	60051	BALL, choke friction	1	29	64244 †	PIN, metering lever	1
12	64228	VALVE, choke	1	30	64237 †	SPRING, metering lever	1
13	64693 †	SCREW, valve	2	31	65482 †	PLUG, welch (main)	1
14	64690	JET, idle air	1	32	30818 †	PLUG, welch (idle)	1
15	64227	CHOKE SHAFT ASSEMBLY	1	33	64243 †	SCREEN, fuel inlet	1
16	64221	RING, throttle shaft retaining	1	34	64232 †	GASKET SET	1
17	64233 †	DIAPHRAGM, fuel pump	1	35	64246	REPAIR KIT	1
18	64230 †	GASKET, fuel pump	1		65386	REPAIR KIT, check valve	1

† Included in repair kit.

HOMELITE XL CHAIN SAWS

NOTES

NOTE 1 - A-64796-C (XL101), A-64797-C (XL102, 103, 104) Crankcases and 65829 Gasket are required when using 63165-3 (XL101, 2" pilot dia.) and A-64542-2 (XL102, 103, 104, 2" pilot dia.) Cylinders. A-64796-A & B (XL101), A-64797-A & B (XL102, 103, 104) Crankcases and 63237 Gasket are required when using 63165-1 (XL101, 1-15/16" pilot dia.) and A-64542-1 (XL102, 103, 104, 1-15/16" pilot dia.) Cylinders.

NOTE 2 - When using 64660-B Compression Relief Pin, 64728 Compression Relief Ball is required.

NOTE 3 - Units below serial #2532641 add 31733-1 Straight Fitting to Crankcase to use A-63948-A Oil Line.

NOTE 4 - For XL101 and XL102 saws below serial number 2618994 and XL103 and XL104 saws below serial number 2629089 supply the following:

Item #19 - Use A-63942 Choke Rod

Item #39 - Use 58362 Grommet (choke)

Item #34 - When replacing the Throttle Handle you must also replace the Choke Rod with new Item #19 - A-63942-1 Choke Rod.

Below serial number 2738662 use 63725 Idle Adjustment Screw on all units.

For units below serial number 2749305 with epoxied oil reservoir cover, A-65572 Oil Reservoir Kit w/Instructions is available to convert it to the "screw together" type oil reservoir cover.

HOMELITE XL CHAIN SAWS

NOTES

NOTE 5 - Below serial number 2799426, A-64796-A Crankcase on XL101 requires A-64798-1 Handle Bar, 65587 Handle Bar Plate, 65360 Handle Bar Pad, 64473 Grommet (2 pcs.), 64613-A Shoulder Screw (2 pcs.) and 63569-3 Handle Bar Bracket.

Below serial number 2805889, A-64797-A Crankcase on XL102, 103, 104 requires A-64799-2 Handle Bar, 65587 Handle Bar Plate, 65360 Handle Bar Pad, 64473 Grommet (2 pcs.), 64613-A Shoulder Screw (2 pcs.) and 63569-3 Handle Bar Bracket.

NOTE 6 - On XL102, 103, 104 saws with old style 2-3/4" Clutch Drums, replace the following as a set:

- Item #27 - Clutch Plate
- Item #28 - Clutch Springs
- Item #29 - Clutch Shoes
- Item #31 - Hub & Drum Assembly - See NOTE 7
- Item #18 - Guide Bar Plate (inner)
- Item #19 - Guide Bar Plate (outer)

NOTE 7 - Units using A-63217 (XL101) and A-64908 (XL102, 103, 104) must use 63860 Thrust Washer, 63990 Inner Race and 64333 Needle Bearing.

Leon's Chainsaw Parts & Repair
Do Not Sell or Reproduce

HOMELITE XL CHAIN SAWS

SPECIAL TOOLS (available on order)

‡ XL101 Only	§ XL102, 103, 104
A-23937-B	WRENCH - combination
22820-5	COLLAR - bearing installation (bearing to shaft)
22828	PLIERS - retaining ring
23136-1	SLEEVE - bearing and shaft installation
23528	WRENCH - socket screw (connecting rod)
23756	PLUG - needle bearing assembly (connecting rod)
23759	SLEEVE - seal protection (back plate)
23846-2	ANVIL - roller bearing disassembly
§ A-23934	SPANNER - clutch (above serial #2617639)
A-23949	TOOL - piston pin removal
A-23960	BRACKET - rotor removal
23972	SLEEVE - seal installation (crankcase w/shaft)
24006-2	PLATE - shaft alignment
A-24051	JACKSCREW (bearing to shaft to crankcase)
‡ 24053	SLEEVE - seal protecting (crankcase)
24054	PLUG - seal assembly (crankcase)
24055	PLUG - bearing and seal assembly (back plate)
A-24057	BEARING REMOVER (back plate)
A-24060	SPANNER - clutch (use on all units below serial #2617639)
64309	Includes: PIN - dowel (3)
§ 24076	SLEEVE - seal protecting (crankcase side)
§ A-24138	REAMER - compression relief valve seat
24230	DRIVER - hand, "pozidriv"
* 24173	DRIVER - check valve installation
A-23841-A	WRENCH - insert

Accessories

* 65543-1	HEAT EXCHANGER
A-64818	SPARK ARRESTOR
* A-65572	KIT. OIL RESERVOIR

Paint

24101	SPRAY CAN - dark blue
22771	SPRAY CAN - vermillion
23560	SPRAY CAN - white

* Denotes new part

Leon's Chainsaw Parts & Repair
Do Not Sell or Reproduce

Leon's Chainsaw Parts & Repair
Do Not Sell or Reproduce



HOMELITE

A **Textron** DIVISION • PORT CHESTER, NEW YORK