

HOMELITE SXL-922

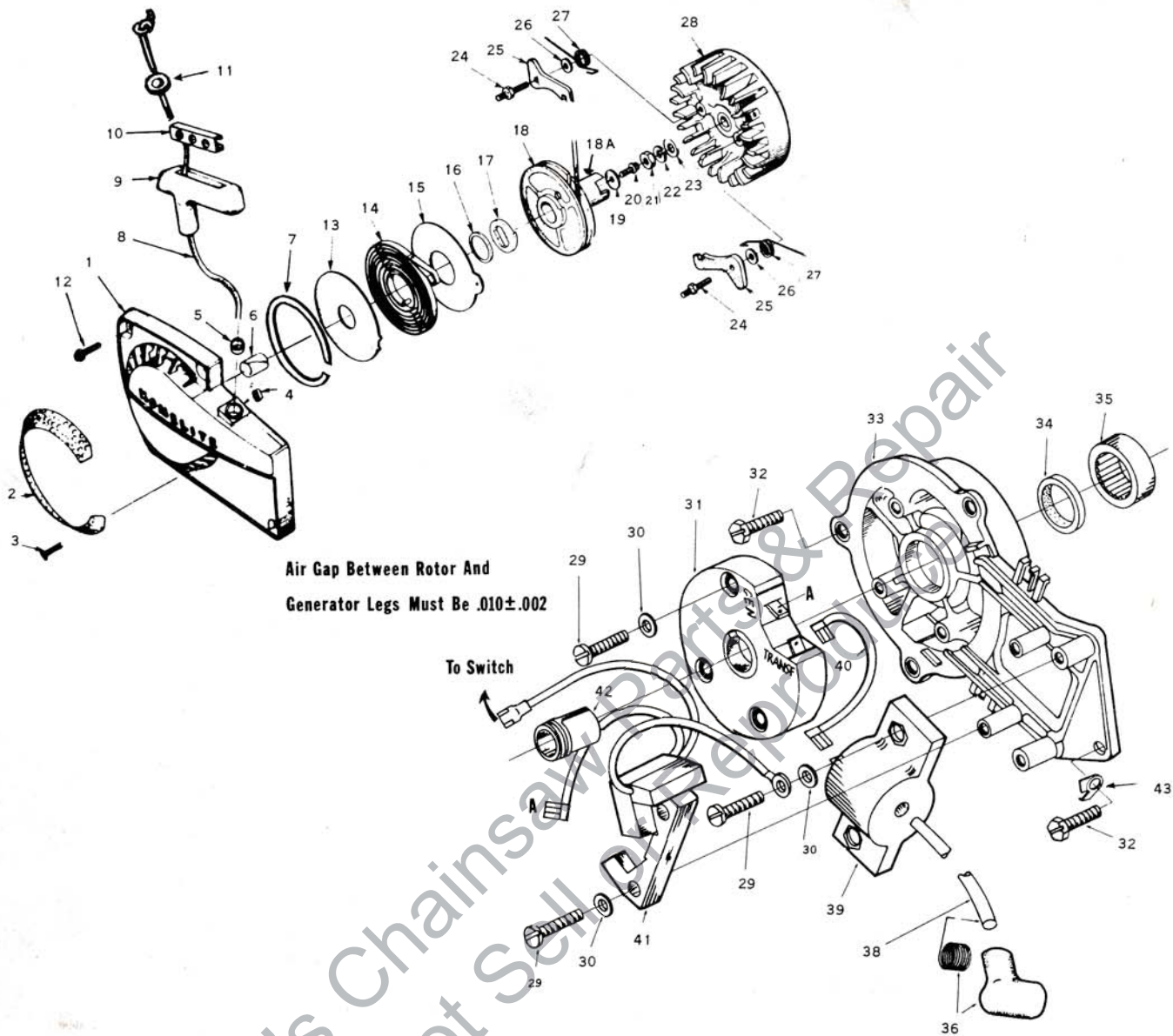

FIGURE 1

No.	Description	Part No.	Qty.	No.	Description	Part No.	Qty.
1	HOUSING fan	A-64504-B	1	22	WASHER lock 3/8	83102	1
2	INCLUDES, screen-air	64420-1	1	23	WASHER flat 3/8	84010	1
3	Studs Drive 2 x 1/4	67191	4	24	STUD-shoulder - pawl	58757-B	2
4	Bushing, Rewind	65830	1	25	PAWL - starter	58756	2
5	Bushing - rope	59313	1	26	WASHER	58851	2
6	Bushing-starter post	64443	1	27	SPRING-pawl	58758	2
7	Ring air flow	67409	1	28	ROTOR magneto	67165	1
8	ROPE starter	58806-T	1	29	SCREW pan head 8-32 x 3/4	82178	7
9	GRIP-rope	58915	1	30	WASHER lock (no. 8)	83022	7
10	INSERT	58847	1	31	MODULE ignition	67162	1
11	WASHER	120773	1	32	SCREW hex head 1/4 - 20 x 5/8	80048	4
12	SCREW-hex head 12 - 24 x 5/8	80676	4	33	BACK plate	A-67618-T	1
13	SHIELD (inner)	63566	1	34	INCLUDES; seal	58688-A	1
14	SPRING - rewind	63268-A	1	35	Bearing rollers	63195	1
15	SHIELD - (outer)	63565-A	1	36	TERMINAL, spark plug	A-33055	1
16	BUSHING spring lock	64400	1	38	LEAD-high tension	67166	1
17	LOCK spring	64049-A	1	39	COIL - transformer	67164	1
18	PULLEY starter	64398-1A	1	40	LEAD transformer	67167	1
18A	CUP starter	64399	1	41	CORE & Generator Coil	67163	1
19	WASHER retaining	58763	1	42	CAP dust	64002	1
20	SCREW-hex hd 10 - 32 x 1/2	80648	1	43	WASHER, tab	67875-1	1
21	NUT hex (3/8 - 24)	81192	1				

ALWAYS FURNISH MODEL AND SERIAL NUMBER WHEN ORDERING PARTS

HOMELITE SXL-922

68480

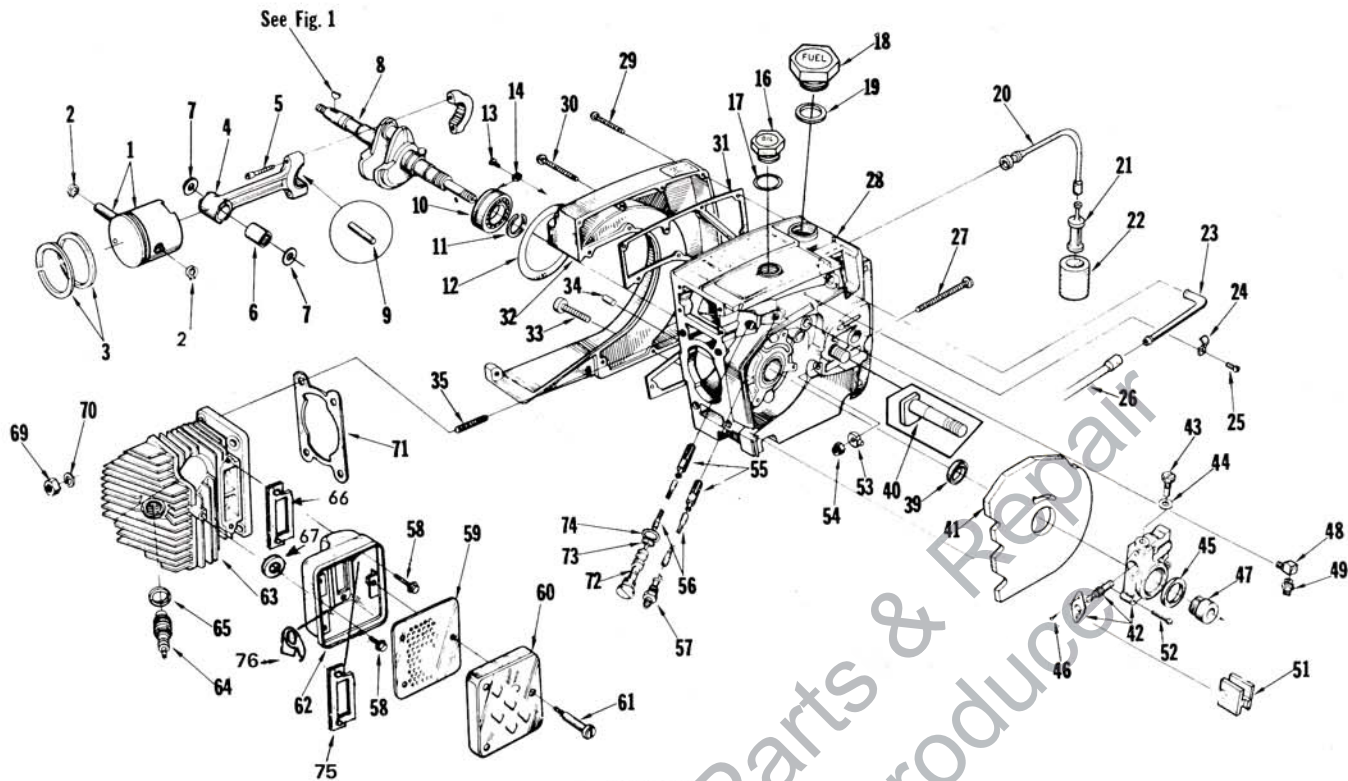

FIGURE 2

No.	Description	Part No.	Qty.	No.	Description	Part No.	Qty.
*1	KIT, PISTON	A-122130	1	34	PIN-dowel	63621	2
2	Includes: RING-piston pin retaining	64742	2	35	STUD	55871	4
3	PISTON RING	55038	2	39	SEAL	58688-A	1
*4	ROD-connecting	A-68008	1	40	BOLT-guide bar	67158	2
5	Includes: SCREW-socket, 8-32 x 9/16	80805	2	41	SHIELD-sawdust	64156	1
6	BEARING-needle	59351	1	42	PUMP-automatic oil	A-68265	1
*7	WASHER-thrust	68010	2	43	Includes: SCREW-cam	64102-A	1
*8	CRANKSHAFT	67168-1T	1	44	GASKET-cam screw	59736	1
9	BEARING-needle (28 rollers)	A-64621	1	45	SEAL-felt	59926	1
10	BEARING-ball	58190-S	1	46	SCREW-pan, 4-40 x 1/4	80919	2
11	RING-retaining	58319-A	1	47	WORM-gear	59675	1
12	"O" RING	67559	1	48	CONNECTOR-elbow	31734	2
13	SCREW-bearing retaining	59704	2	49	FITTING-tube	65696	1
14	WASHER-lock	59705	2	51	GROMMET-oil line	65357	1
16	CAP-oil filler	A-65284-T	1	52	SCREW-pan, 8-32 x 3/4	80567	3
17	Includes: "O" RING	65133	1	*53	PIN-guide bar adjusting	67586-1A	1
	VALVE-check (not shown)	63718	1	54	NUT-flexloc, 1/4-20	81108	1
*18	CAP-fuel filler	A-65283-AT	1	55	FILTER-oil	A-64293	2
*19	Includes: GASKET	68961	1	56	LINE-oil pick-up	64356	2
	VALVE-check (not shown)	63718	1	57	CONNECTOR-oil filter	65695	1
20	LINE-fuel (flexible)	65593	1	*58	SCREW-hex, 1/4 -20 x 5/8	80402	3
21	FILTER-fuel	A-59251	1	59	BAFFLE-muffler	65633	1
22	Includes: FILTER-fuel	59253	1	*60	CAP-muffler	68679-1T	1
23	CONNECTOR-fuel line	67080	1	*61	SCREW-shoulder	68480	3
24	CLAMP-fuel line	65597-1	1	*62	BODY-muffler	A-68979-T	1
25	SCREW-pan, 6-32 x 5/16	80605	1	*63	CYLINDER-2" bore	67455-1T	1
26	LINE-fuel	65718	1	64	SPARK PLUG	63547-S	1
27	SCREW-guide bar adjusting	63367	1	65	Includes: GASKET	25038	1
28	CRANKCASE & TANK	A-68023-T	1	66	GASKET, muffler	120910	1
29	Includes: SCREW-fil, 8-32 x 5/8	82146	6	67	WASHER, muffler	84004	1
30	SCREW-fil, 8-32 x 2-3/16	82155	8	69	NUT-hex, 1/4-28	81065-2	4
31	GASKET-fuel tank	67159	1	70	WASHER-lock, 1/4	83009	4
32	COVER-fuel tank	67153-2	1	71	GASKET-cylinder	63778-1	1
33	SCREW-fil, 8-32 x 1 3/4	82147	1	72	TUBE-oil line	63452-A	1
				73	"O" RING	58406	1
				74	GASKET-oil line tube	63751	1
				*75	PLATE-muffler body	122138	1
				*76	WASHER-tab	122159	1

* Denotes new parts

ALWAYS FURNISH MODEL AND SERIAL NUMBER WHEN ORDERING PARTS.

HOMELITE SXL-922

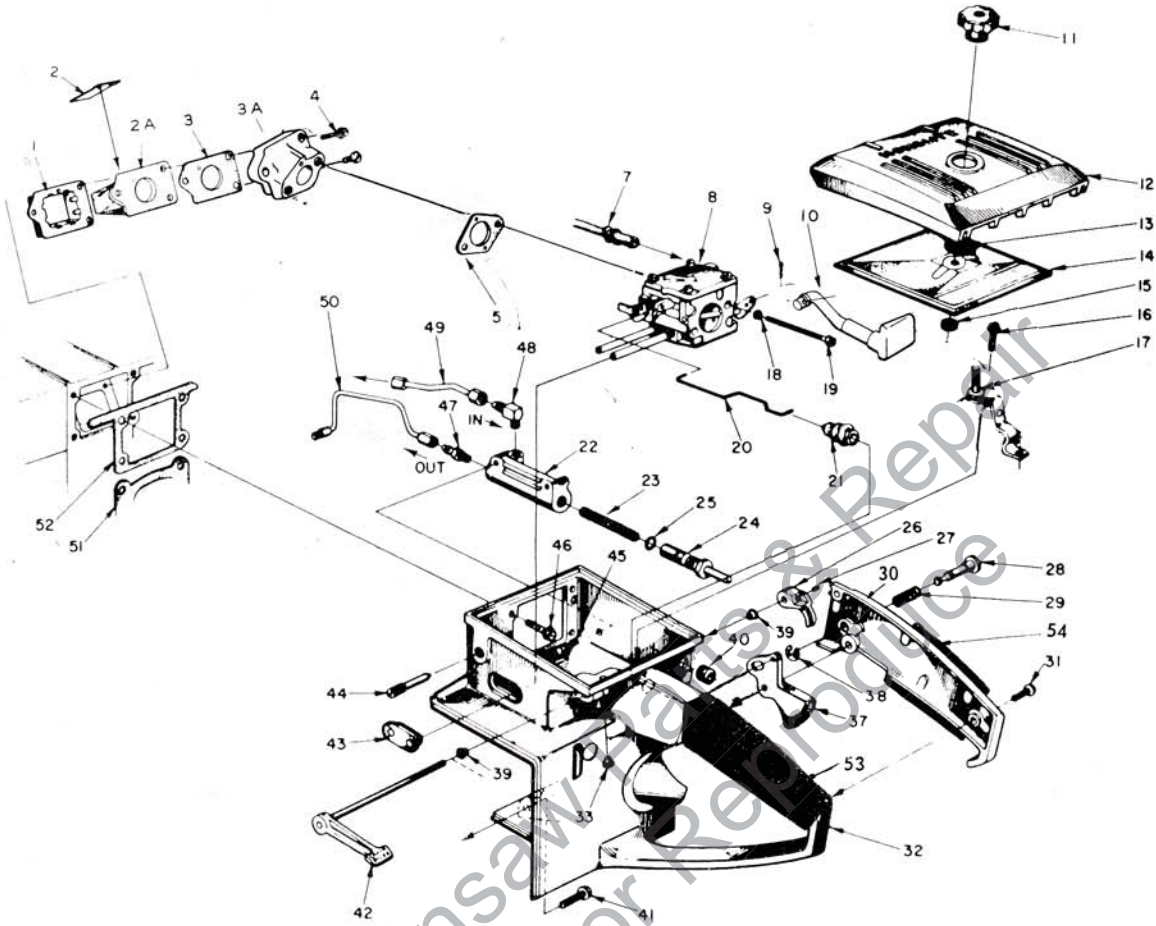
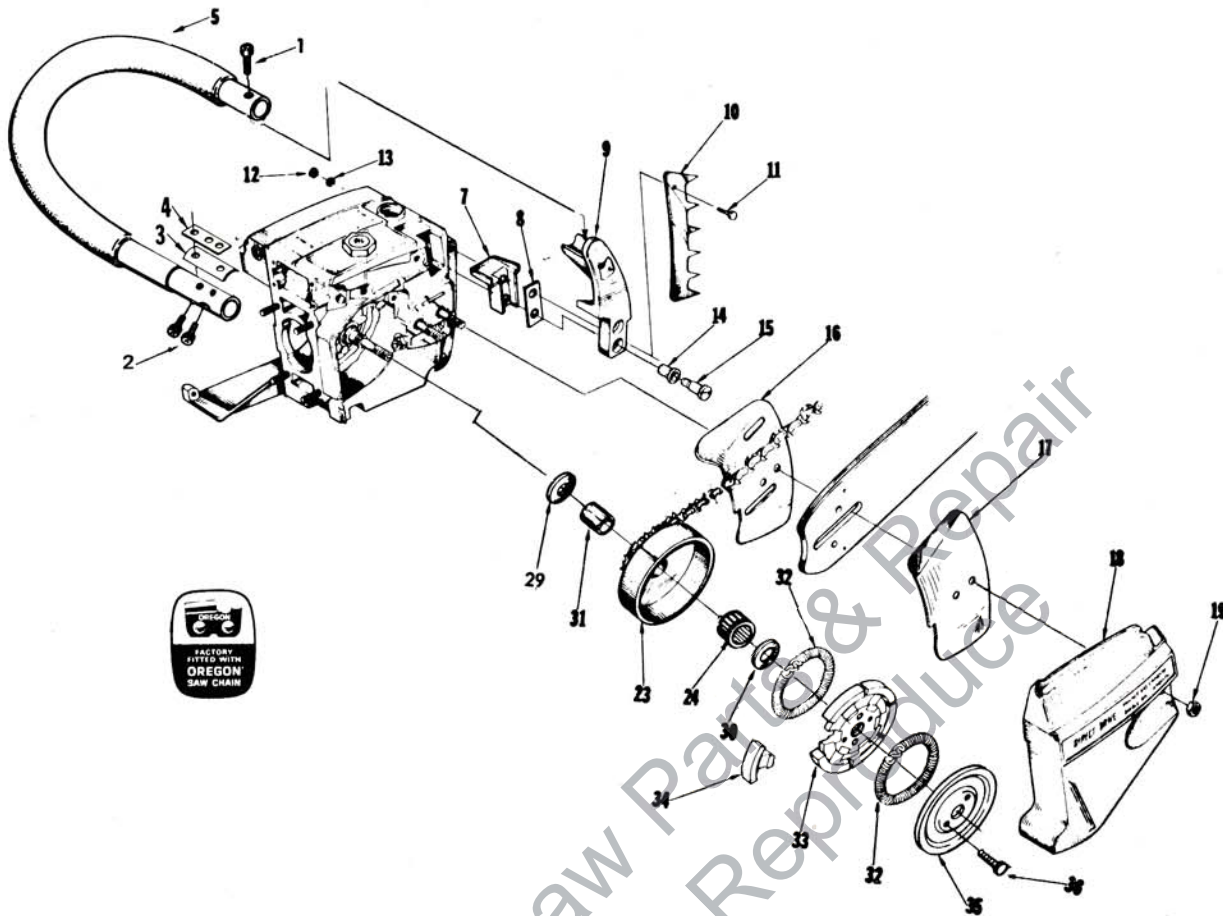

FIGURE 3

No.	Description	Part No.	Qty.	No.	Description	Part No.	Qty.
1	RETAINER - reed valve	63370-A	1	26	LEVER - oiler	63280-2A	1
2	VALVE - reed	63166-A	4	27	SCREW - Fil. Ho. 8-32 x 1/4	80018	1
2A	SEAT - reed valve	63371-B	1	28	PIN - throttle lock	58924-4	1
3	GASKET - seat	65483	1	29	SPRING - lock	58405	1
*3A	SPACER - reed valve seat	A-67460-1	1	*30	COVER - throttle handle	A-122053	1
*4	SCREW -	82196	3		Includes: BUSHING - pin	59064	1
*5	GASKET - carburetor	67540	1	31	SCREW - pan, 8-32 x 1/2	80560	2
7	LINE - fuel	65718	1	*32	HANDLE - throttle	A-68025AT	1
*8	CARBURETOR	A-122044	1	33	Includes: BUMPER - rubber	56298	1
9	PIN - cotter	86324	1	37	THROTTLE - trigger	58859	1
*10	ROD - choke	67201-1	1	38	RING - retaining	58409	1
11	NUT - cover mounting	A-67639	1	39	BUSHING - throttle handle	63400	2
12	COVER - air filter	63634-1	1	*40	GROMMET	64862	1
13	RING - retainer	58319-A	1	41	SCREW - hex, 12-24 x 7/8	80891	1
14	FILTER ELEMENT - air	63341	1	*42	LEVER - oiler w/shaft	A-63327-T	1
15	GASKET - mounting nut	58392-1	1	43	GROMMET	64664	1
16	SCREW - hex. 12-24 x 1/2	80821	1	*44	SCREW - idle adjustment	63369-A	1
*17	BRACKET, air filter	A-67100	1	45	SCREW - sl. hex, 8-32 x 1/2	80983	2
18	WASHER - lock, No. 10	83046	2	46	SCREW - hex. 12-24 x 5/8	80676	4
*19	SCREW - hex. 10-32 x 1-7/8	82179	2	47	VALVE - check (outlet)	A-65948	1
20	ROD - throttle	63266-A	1	48	VALVE - check (inlet)	A-65502	1
21	BOOT - throttle rod	58348	1	49	LINE - oil (intake)	A-120856	1
*22	BODY - oil pump	63343-3T	1	50	LINE - oil	A-120862	1
23	SPRING - plunger	59293	1	51	GASKET - cylinder	63778-1	1
24	PLUNGER - oil pump	A-57834-14	1	*52	GASKET - throttle handle	63779-C	1
	Includes: "O" RING - shaft	59074	1	53	GRIP, Throttle handle	68767	1
25	"O" RING - plunger	74388	1	54	GRIP, Throt. Hand. cover	68768	1

ALWAYS FURNISH MODEL AND SERIAL NUMBER WHEN ORDERING PARTS.

HOMELITE SXL-922



No.	Description	Part No.	Qty.	No.	Description	Part No.	Qty.
1	SCREW, fil hd 1/4-20 x 1	80060	1	16	PLATE—guide bar (inner)	67160	1
* 2	SCREW, fil hd 1/4-20 x 1-1/8	122064	2	17	PLATE—guide bar (outer)	67161	1
* 3	SPACER	68898-1	1	* 18	COVER—drivecase	67156-3	1
* 4	PLATE	65599	1	19	NUT—hex, 3/8-16	81089-2	2
5	HANDLE BAR — Flush cut Wrap around	A-121854-1 121925-1	1 1	23	SPROCKET & DRUM—3/8 pitch, 8 tooth	A-65885-T	1
* 7	MOUNT — Shock	65509	1	24	Includes: BEARING—roller	64124	1
8	PLATE, Handle bar bracker	65598	1	29	WASHER, thrust	121895	1
9	BRACKET, Handle bar flush Handle bar Wrap	68766-2 68766-4	1 1	30	WASHER—thrust	63462	1
* 10	KIT — spiked bumper	A-63720	1	31	RACE—inner	64129	1
11	Includes: SCREW—hex, 12-24 x 3/4	80867	2	32	SPRING—clutch	67441	2
12	NUT—12-24	81068	2	33	SPIDER—clutch	65723-2	1
13	WASHER—lock, No. 12	83056	2	34	SHOE—clutch	67896-1	6
14	GROMMET	65519	2	35	COVER—clutch	58751-1	1
15	SCREW—shoulder	65521	2	36	SCREW—hex, 10-32 x 1/2	80361-1	2

*Denotes new parts

SPECIAL TOOLS (available on order)

Part No.	Description	Part No.	Description
*A-122140	COMBINATION WRENCH	23972	SLEEVE — seal installation (crankcase)
*A-122055	PULLER	23957	PLUG — seal installation (crankcase)
22828	PLIERS — piston snap ring	24306	SHIM — air gap
23528	WRENCH — socket screw (conn. rod)	23420	PLUG — bearing installation (sprocket)
23955	PLUG — bearing installation (conn. rod)	23956	PLUG — bearing and seal installation (back plate)
A-23965	JACKSCREW	23846-2	ANVIL — bearing disassembling (back plate)
23136-1	BODY — jackscrew	24006-1	PLATE — crankshaft aligning
24302	PLUG — seal installation (back plate 910)	120875	BIT — posidrive No. 2
22820-4	COLLAR — bearing installation		PAINT
23846-1	ANVIL — crankshaft installation	22772	SPRAY CAN — black
23971	SLEEVE — seal protecting (crankcase)	23475	SPRAY CAN — red

ALWAYS FURNISH MODEL AND SERIAL NUMBER WHEN ORDERING PARTS.

HOMELITE SXL-922

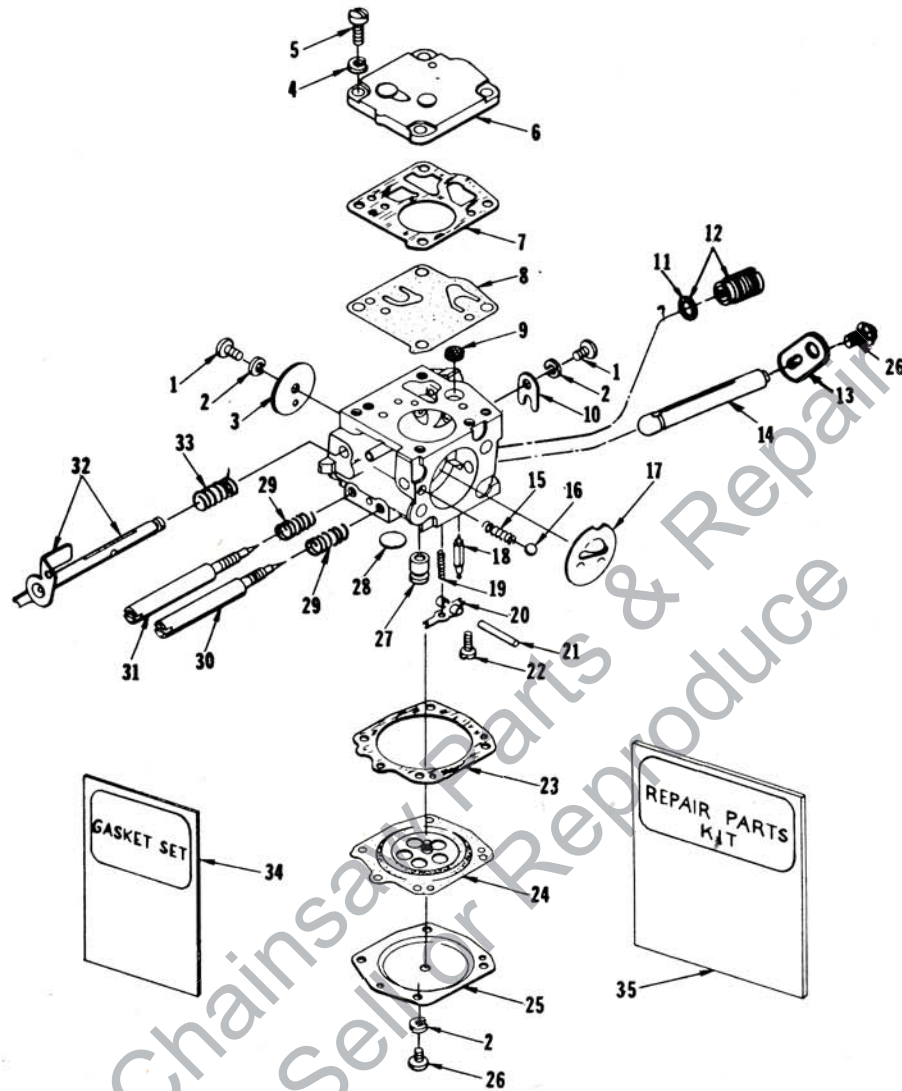

A 122044
HS 120A

No.	Description	Part No.	Qty.	No.	Description	Part No.	Qty.
1	SCREW—rd., 4-40 x 3/16	† 80264	2	19	SPRING—control lever	† 55759	1
2	WASHER—lock, No. 4	† 83008-1	6	20	LEVER—inlet control	† 59716	1
3	SHUTTER—throttle	67994	1	21	PIN—control lever fulcrum	† 58977	1
4	WASHER—lock, No. 6	83024	4	22	SCREW—oval, 4-40 x 1/4	† 65798	1
5	SCREW—fil, 6-32 x 3/8	80275	4	23	GASKET—main diaphragm	58978	1
6	COVER—fuel pump diaphragm	58975	1	24	DIAPHRAGM—main control	† 58988	1
7	GASKET—pump diaphragm	58981	1	25	COVER—main diaphragm	58979	1
8	DIAPHRAGM—fuel pump	† 58980-R	1	26	SCREW—rd., 4-40 x 1/4	80591	5
9	SCREEN—fuel inlet	† 58974	1	27	VALVE—check (See Note)	69154	1
10	CLIP—throttle shaft retaining	58982	1	28	PLUG—extension (large)	† 58991	1
11	GASKET	74060	1	29	SPRING—adjustment needle	† 73075	2
12	VALVE—governor	A-65801	1	30	SCREW—main adjustment	† 63676	1
13	LEVER—choke	68397	1	31	SCREW—idle adjustment	† 63677	1
14	SHAFT—choke	65799	1	32	SHAFT—throttle w/lever	A-67995	1
15	SPRING—choke friction	73264	1	33	SPRING—throttle opening	† 59460	1
16	BALL—choke friction	25527	2	34	GASKET—set	67866	1
17	SHUTTER—choke	58984	1	35	REPAIR KIT	67870	1
18	NEEDLE—inlet	† 59717	1				

† Included in Repair Kit
* Denotes new parts



ALWAYS FURNISH MODEL AND SERIAL NUMBER WHEN ORDERING PARTS.