

# HOMELITE®

CHAIN SAW

**SUPER**

**VI 200**

Leon's Chainsaw Parts & Repair  
Do Not Sell or Reproduce



**INDUSTRIES**

A DIVISION OF **textron** CANADA, LIMITED

180 Labrosse, Ave., Pointe Claire, Que.

# Super VI 200 Chain Saw

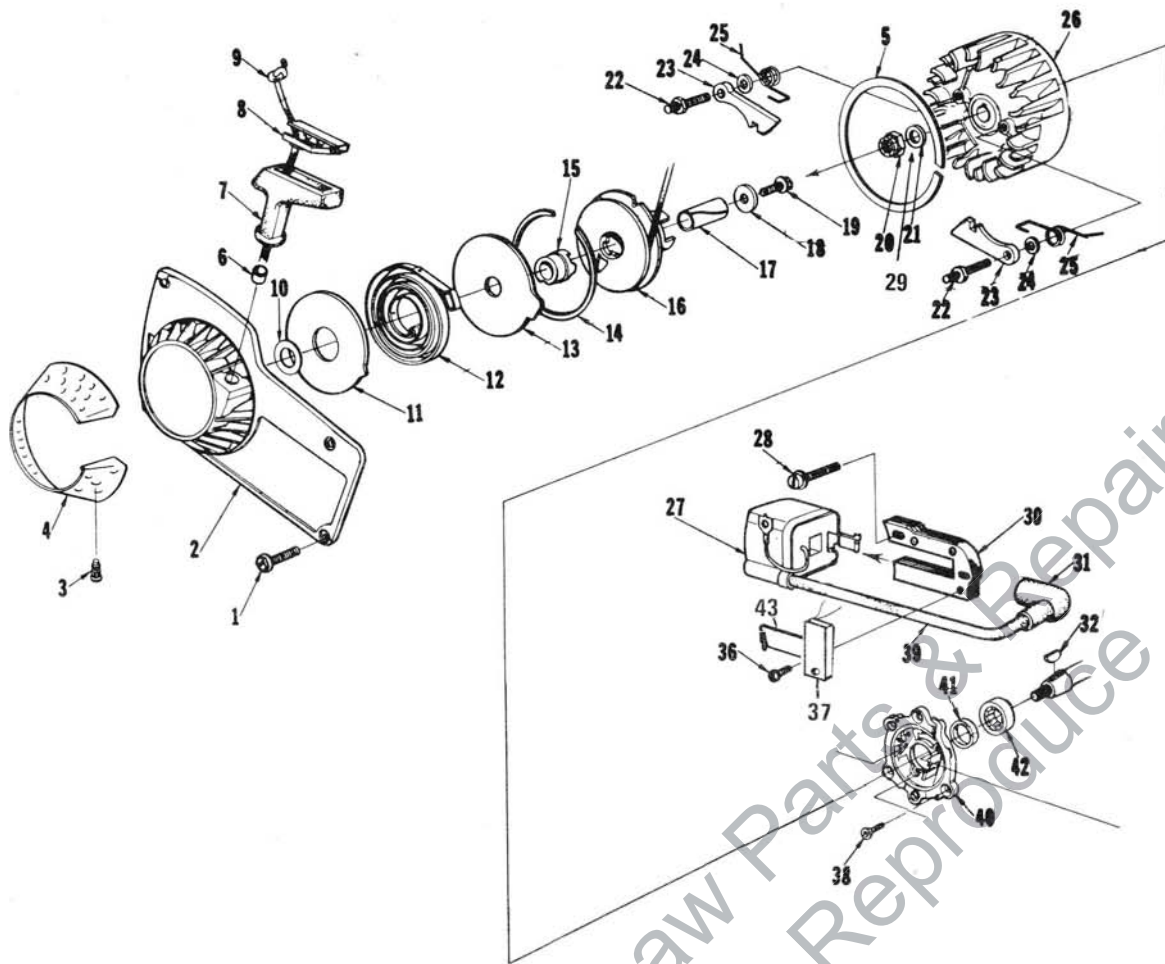

**FIGURE 1**

No.	Description	Part No.	Qty.	No.	Description	Part No.	Qty.
1	SCREW-hex, 10-32 x 1/2	80648	4	21	WASHER-flat, 5/16	84065-1	1
2	HOUSING-fan	A-67192-A	1	*22	STUD-shoulder	63877-B	2
3	Includes: STUD-drive	67191	4	23	PAWL-starter	64442	2
4	SCREEN-fan housing	65491	1	24	WASHER-lock	83056	2
5	RING-air flow	67222	1	25	SPRING-starter pawl	65375-1	2
6	BUSHING-starter rope	67177	1	26	ROTOR-magneto	63637	1
* 7	GRIP-starting rope	64155-A	1	*27	COIL-ignition	A-122454	1
* 8	INSERT-rope retaining	68837-T	1	28	SCREW-coil core	82248	2
9	ROPE-starter	63869	1	29	WASHER Lock	83030	1
10	WASHER	67185	1	30	CORE-coil	54422	1
11	SHIELD-spring (inner)	63713	1	31	TERMINAL-spark plug	A-33055	1
12	SPRING-rewind	63870	1	32	KEY-woodruff	75078	1
13	SHIELD-spring (outer)	63714	1	*36	SCREW #6-32 x 3/4 Taptite	122409	1
14	RING-shield retaining	63875	1	*37	IGNITION Module	A-122350	1
15	LOCK-spring	64948	1	38	SCREW-back plate retainer	65321	5
16	PULLEY & CUP ASSEMBLY	A-63952-T	1	39	LEAD-high tension	58966	1
17	BUSHING-starter post	64374	1	40	PLATE-back	A-68142	1
18	WASHER-retaining	63606	1	*41	Includes: SEAL	12282-A	1
19	SCREW-hex, 10-32 x 1/2	80648	1	42	BEARING-roller	67395	1
20	NUT-jam, 5/16-24	122168	1	43	CLIP-coil retaining	54423	1

\*Denotes New Parts

# Super VI 200 Chain Saw

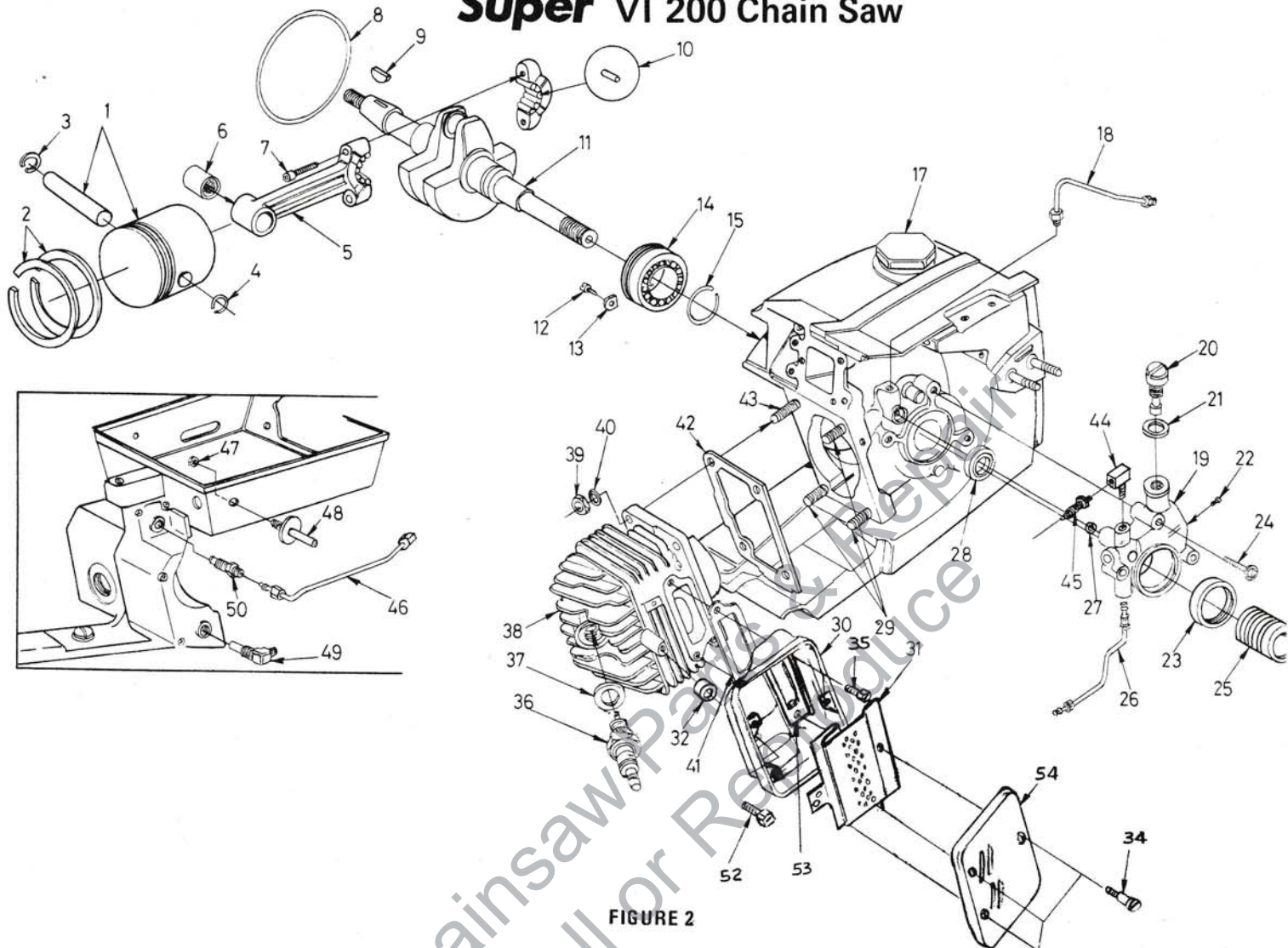

FIGURE 2

No.	Description	Part No.	Qty.	No.	Description	Part No.	Qty.
1	PISTON & PIN Includes:	A-121690	1	27	"O" RING	59074	1
2	PISTON RING	59436	2	28	SEAL	58308-B	1
3	RING-retaining	75120	1	29	STUD-cylinder (short)	55871	3
4	RING-piston pin retaining	64813	1	30	BODY-muffer	A-122300-1	1
5	ROD-connecting Includes:	A-68498-A	1	31	BAFFLE-muffer	122303	1
6	BEARING-needle	67408	1	32	SPACER	68456-1A	1
7	SCREW	80541	2	34	SCREW-shoulder	64614-A	3
8	"O" RING	58785	1	* 35	SCREW-hex, 12-24 x 5/8	122403	2
9	KEY-Woodruff	75078	1	36	SPARK PLUG (J-7)	122066	1
10	ROLLER-needle (set of 25)	A-69050	1	37	Includes: GASKET	25038	1
11	CRANKSHAFT	68730	1	38	CYLINDER	A-122325-A	1
12	SCREW-Bearing retainer	59704	2	39	NUT-hex, 1/4-28	81065-2	4
13	WASHER-special	63905	2	40	WASHER-lock, 1/4	83009	4
14	BEARING-ball	63865	1	41	GASKET	121474	1
15	RING-retaining	58319-A	1	42	GASKET-cylinder	65829	1
17	CAP-fuel filler	A-69500	1	43	STUD-cylinder (long)	63868	1
18	LINE-oil (Auto. upper)	A-63919	1	44	CONNECTOR-elbow	31734	1
19	PUMP-automatic oil Includes:	A-67023-T	1	45	FITTING-straight	65696	1
20	SCREW-cam	64102-A	1	46	LINE-oil (manual)	A-122198	1
21	GASKET	59736	1	47	NUT-hex, 1/4-20 FLEXLOCK	81108	2
22	SCREW-pan, 4-40 x 1/4	80919	2	48	SUPPORT	122191	2
23	SEAL-felt	64393	1	49	FILTER-oil	A-64741-T	1
24	SCREW-pan 8-32 x 7/8	80568	3	50	VALVE-check	A-65948-T	1
25	WORM-oil pump	63228	1	* 52	SCREW-Hex (#12-24 x 1")	122404	1
26	LINE-oil (auto. lower)	A-121734	1	* 53	PLATE-Muffer	64127-T	1
				54	CAP-Muffer	122305-1	1

\*Denotes New Parts

# Super VI 200 Chain Saw

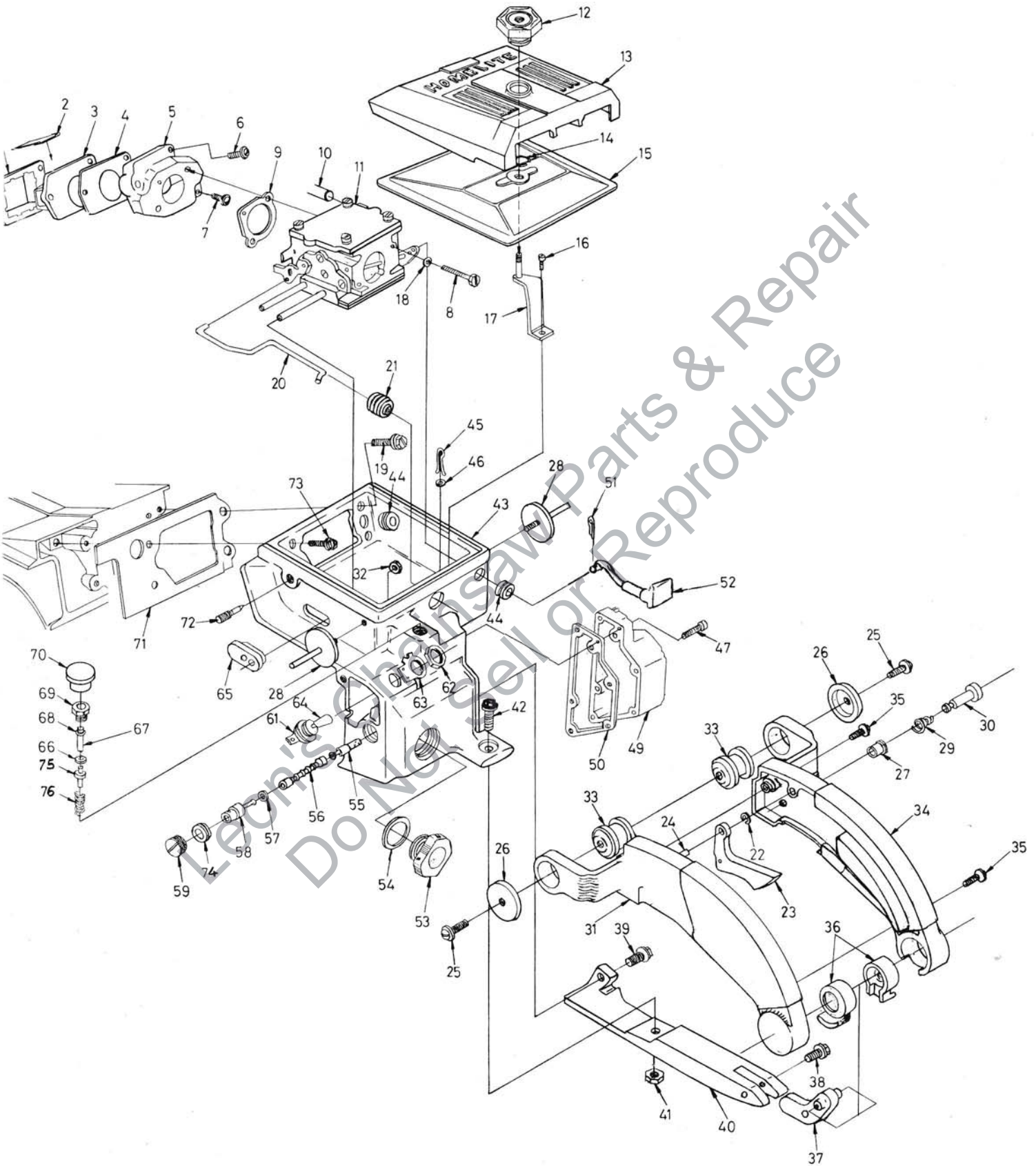

FIGURE 3

ALWAYS FURNISH MODEL AND SERIAL NUMBER WHEN ORDERING PARTS.

# Super VI 200 Chain Saw

No.	Description	Part No.	Qty.	No.	Description	Part No.	Qty.
1	RETAINER-reed valve	64253-A	1	42	SCREW-hex 12-24 x 5/8	80676	1
2	REED-valve	59678-B	4	43	CARBURETOR CHAMBER	A-69163-T	1
3	SEAT-reed valve	64252	1		Includes:		
4	GASKET-reed valve seat	64266-T	1	44	GROMMET	64862	2
5	MANIFOLD-intake	A-67502-A	1	45	PIN-cotter	86301	1
	Includes:			46	WASHER-felt	63290	1
6	SCREW-pan, 8-32 x 1¼	82174	2	47	SCREW-fil, 8-32 x 3/4	82156	6
7	SCREW-pan, 8-32 x 1	82173	1				
8	SCREW-hex, 10-32 x 1-7/8	82179	2	49	COVER, oil tank	A-68120-A	1
9	GASKET-carburetor	67631	1		Includes:		
10	LINE-fuel	63544-A	1		PLUG-pipe (not shown)	59571	1
11	CARBURETOR (HS-125A)	A-122172	1	50	GASKET-oil tank	67265	1
12	NUT-cover mounting	A-67627	1	51	PIN-cotter	86324	1
13	COVER-air filter	63183-6T	1	52	ROD-choke	67201-2	1
14	RING-retaining	58319-A	1	53	CAP-oil (vented)	A-65284-AT	1
*15	FILTER ELEMENT-air	122436-1	1		Includes:		
16	SCREW-hex, 12-24 x ½	80821	1	*54	GASKET	69834	1
17	BRACKET-air filter cover	A-63576	1	*	VALVE-vent (not shown)	69451	1
18	WASHER-lock, #10	83046	2	55	FILTER-oil (manual)	A-64293	1
19	SCREW-hex, 12-24 x 7/8	80891	1	56	LINE-flexible oil	64356	1
20	ROD-throttle	63896-A	1	57	GASKET	59736	1
21	BOOT-throttle rod	67634	1	58	FITTING-check valve	A-63936	1
22	RING-retaining	58409	1	59	SCREW-set	63113	1
23	TRIGGER-throttle	63212-A	1	61	SWITCH	A-63938	1
24	PIN-trigger	65601	1	62	Includes: NUT	72084-A1	1
25	SCREW-pan, 10-32 x 5/16	82175	2	63	PLATE-"on-off"	63910	1
26	WASHER	68998-1	2	64	SLEEVE-grounding switch	69092	1
27	BUSHING-nylon	59064	1	65	GROMMET-"hi-lo"	122278	1
28	SUPPORT	122191	2	66	"O" RING	58406	1
29	SPRING-throttle latch	58405	1	67	ROD-plunger	A-121658-1	1
30	PIN-throttle latch	58924-4	1		Includes:		
31	HANDLE-throttle (left)	A-122291	1	68	"O" Ring	59074	1
32	NUT-hex, ¼-20 FLEXLOCK	81108	2	69	NUT-plunger	121293	1
33	ISOLATOR	68320	2	70	BUTTON-oil pump	57289-1T	1
34	HANDLE-throttle (right)	A-122292	1	71	GASKET-carburetor chamber	64267-T	1
35	SCREW-pan, 8-32 x 5/8	80582	2	72	SCREW-idle adjustment	65522	1
36	ISOLATOR	68325-A	2	73	SCREW-hex, 12-24 x 5/8	80676	3
37	SUPPORT-handle	122235-2	1	74	GROMMET	64474	1
38	SCREW-hex, 12-24 x 7/8	80891	1	75	PLUNGER-oil pump	65081-AT	1
39	SCREW-hex, 12-24 x 1-¼	80994	1	76	SPRING-plunger	65080	1
40	BASE-handle	122192-2	1				
41	NUT-hex, 12-24	81225	1				

\*Denotes New Parts

FIGURE 3

# Super VI 200 Chain Saw

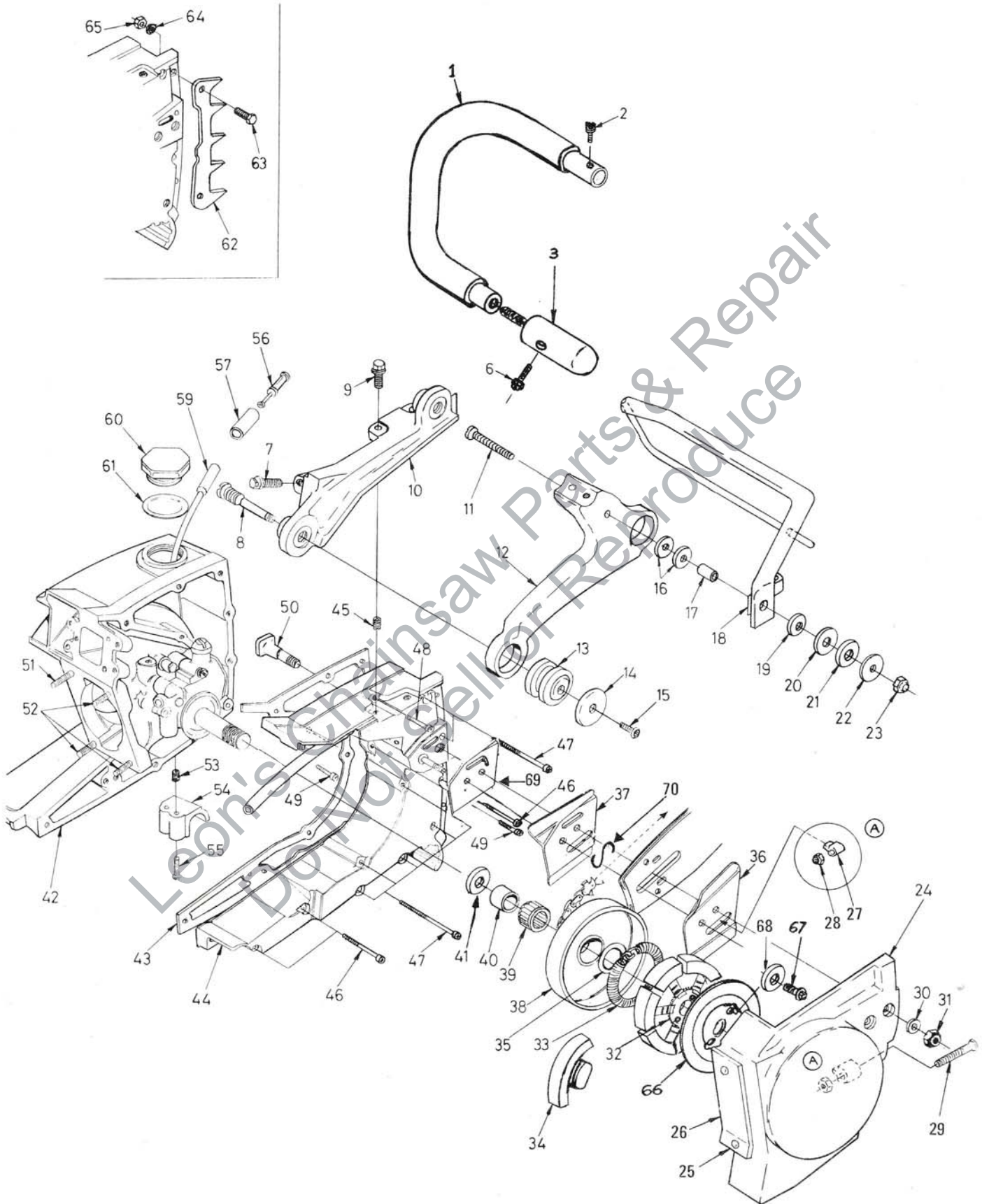

FIGURE 4

ALWAYS FURNISH MODEL AND SERIAL NUMBER WHEN ORDERING PARTS.

# Super VI 200 Chain Saw

No.	Description	Part No.	Qty.	No.	Description	Part No.	Qty.
1	HANDLE BAR-flush cut	A-122349-1	1	42	CRANKCASE & TANK	A-69162-T	1
2	SCREW-fil, 10-32 x 1	80041	1		Includes:		
3	BRACKET Vib. mount	A-122345-A	1		PIN-dowel (not shown)	71430	2
6	SCREW-hex, 1/4-20 x 1-1/4	80912	1		PIN-dowel (not shown)	65365	2
7	SCREW-hex, 12-24 x 7/8	80891	1		SEAL-(see fig. 2 index #28)	58308-B	1
8	SCREW-vibration mount	68997-A	2	43	GASKET-fuel tank	65364-A	1
9	SCREW-hex, 10-32 x 5/8	80704	2	44	COVER-fuel tank	A-68040-AT	1
10	BRACKET-vibration mount	68992-2B	1		Includes:		
11	SCREW-flat, 12-24 x 1-1/2	†82223	1	45	INSERT-taplock	72489	2
12	BRACKET-handle bar	A-69164-B	1	46	SCREW-fil, 8-32 x 1-7/8	82154	3
13	ISOLATOR-vibration	68320	2	47	SCREW-fil, 8-32 x 2-3/16	82155	7
14	WASHER	68998-1	2	48	SCREW-fil, 8-32 x 1-1/4	82152	1
15	SCREW, Pan HD 10-32 x 5/16	82175	2	49	SCREW-fil, 8-32 x 15/16	82151	2
16	WASHER-flat	†84006-1	2	50	BOLT-guide bar	67193	2
17	BUSHING	†88934-1	1	51	STUD-cylinder (long)	63868	1
18	GUARD-anti-kickback	†A-68932-1	1	52	STUD-cylinder (short)	55871	3
19	WASHER-flat	†84099	1	53	INSERT-taplock	72489	2
20	WASHER-flat	†68939-1	1	54	STOP-handle bar	67506-2	1
21	WASHER	†68935	1	55	SCREW-pan, 10-32 x 5/8	80572	2
22	WASHER-flat	†68940-1	1	56	FILTER-fuel	A-59251	1
23	NUT- 12-24	†81222	1	57	Includes: FILTER-felt	59253	1
24	COVER-chain	A-69089-1AT	1	59	LINE-fuel	63544-A	1
	Includes:			60	CAP-fuel filler	A-69500	1
25	RIVET-oval head	85061	2		Includes: GASKET	69501	1
26	SHIELD-sawdust	64618	1	61			
*27	PIN-bar adjusting	122432-1	1	62	BUMPER-spiked	†A-64722	1
28	NUT-lock, 10-32	81109-2	1		Includes:		
29	SCREW-guide bar adjusting	65175-A	1	63	SCREW-hex, 12-24 x 5/8	†80676	2
30	WASHER-flat, 5/16	84032	2	64	WASHER-lock, #12	†83056	2
31	NUT-hex, 5/16-18	81196	2	65	NUT-hex, 12-24	†81068	2
32	SPIDER-clutch	122042-2	1	66	COVER-CLUTCH	12772	1
33	SPRING-clutch	67441	2	*67	SCREW-HEX 10-32 x 1/2	122381	2
34	SHOE-clutch	69754-1	6	*68	WASHER	12940	2
35	WASHER-thrust	121901	1	*69	PLATE, Adapter	122430	1
*36	PLATE-guide bar (outer)	122434	1	*70	SPRING	122431	1
*37	PLATE-guide bar (inner)	122433	1		HANDLE BAR (wrap around)	†A-122249-1	1
38	SPROCKET & DRUM	A-59553-1T	1		SPACER BAR	† 122132-1	1
39	BEARING-cage	64333	1		SCREW Fil, 1/4-20 x 1 1/8"	† 122064	1
40	RACE-inner	63990	1		KIT, ANTI-KICKBACK	†A-68954	1
*41	WASHER-thrust	122435	1		(includes Items 11 & 16 to 23)		
					† OPTIONAL EQUIPMENT		

\* Denotes New Parts

FIGURE 4

SPECIAL TOOLS (available on order)		Part No.	Description	Part No.	Description
A-122140	WRENCH-combination	23846-2	ANVIL-roller bearing disassembly	A-24057	BEARING REMOVER-
22820-5	COLLAR-bearing installation	A-122055	PULLER		(back plate)
	(bearing to shaft)	A-23949	TOOL-piston pin removal	24076	SLEEVE-seal protection
22828	PLIERS-retaining ring	A-23960	BRACKET-rotor removal		(crankcase side)
23136-1	SLEEVE-bearing and shaft	23972	SLEEVE-seal installation	24230	DRIVER-hand, pozidriv
	installation	24006-2	PLATE-shaft alignment	24173	DRIVER-check valve installation
23528	WRENCH-socket screw	A-24051	JACKSCREW (bearing to shaft	23987	SHIM, Magneto Gap
	(connecting rod)		to crankcase)	120875	BIT-pozidriv No. 2
23756	PLUG-needle bearing	24054	PLUG-seal assembly		
	(connecting rod)		(crankcase)		
23759	SLEEVE-seal protection	24055	PLUG-bearing and seal		
	(back plate)		assembly (back plate)		
				<b>PAINT</b>	
				23475	SPRAY CAN-red paint

# Super VI 200 Chain Saw

A-122172

HS-125A

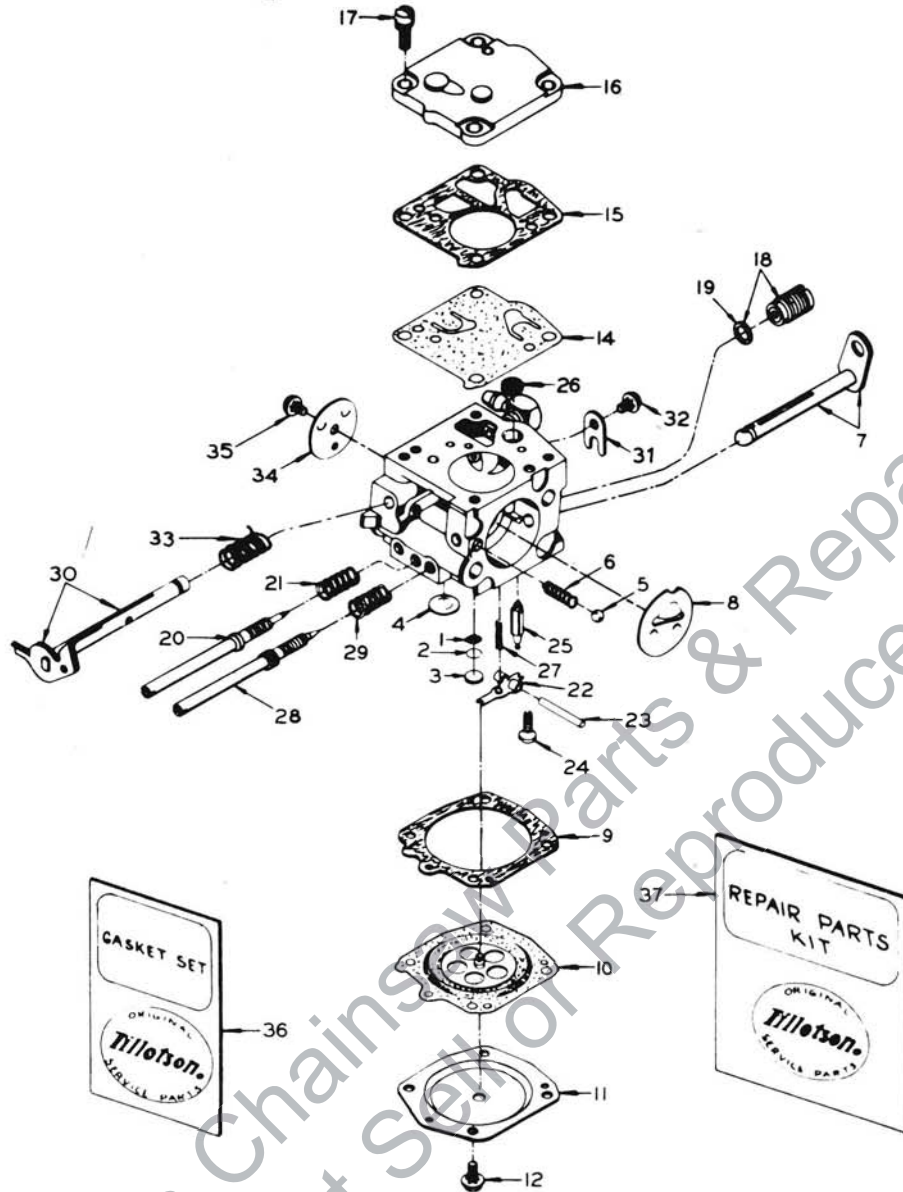

No.	Part Name	Part No.	Qty.	No.	Part Name	Part No.	Qty.
1	Body Channel Screen	122219	1	20	Idle Mixture Screw	122217	1
2	Body Channel Screen Ret. Ring	57819	1	21	*Idle Mixture Screw Spring	54440	1
3	*Body Channel Welch Plug (Small)	58994	1	22	*Inlet Control Lever	59716	1
4	*Body Channel Welch Plug (Large)	58991	1	23	*Inlet Pinion Pin	58977	1
5	Choke Friction Ball	25527	2	24	*Inlet Pinion Pin Ret. Screw	65798	1
6	Choke Friction Spring	73264	1	25	Inlet Needle	59717	1
7	Choke Shaft & Lever	A-122216	1	26	*Inlet Screen	122211	1
8	Choke Shutter	58984	1	27	*Inlet Tension Spring	65603	1
9	Diaphragm Gasket	58978	1	28	High Speed Mixture Screw	122218	1
10	*Diaphragm	58988	1	29	*High Speed Mixture Screw Spring	73075	1
11	Diaphragm Cover	58979	1	30	Throttle Shaft & Lever	A-69153	1
12	Diaphragm Cover Ret. Screw & Lockwasher (4)	80591	4	31	Throttle Shaft Clip	58982	1
14	*Fuel Pump Diaphragm	58980-R	1	32	Throttle Shaft Clip Ret. Screw & Lockwasher	80264	2
15	Fuel Pump Gasket	58981	1	33	*Throttle Shaft Return Spring	122298	1
16	Fuel Pump Cover	58975	1	34	Throttle Shutter	67994	1
17	Fuel Pump Cover Ret. Screw & Lockwasher (4)	80275	4	35	*Throttle Shutter Screw	80264	2
18	Governor Valve Assembly	A-122213	1	36	*Gasket Set	67866	1
19	Governor Valve Assembly Gasket	74060	1	37	Repair Kit	A-121994	1

(\* ) Indicates contents of Repair Kit

