

PARTS LIST

HOMELITE®

Super 2

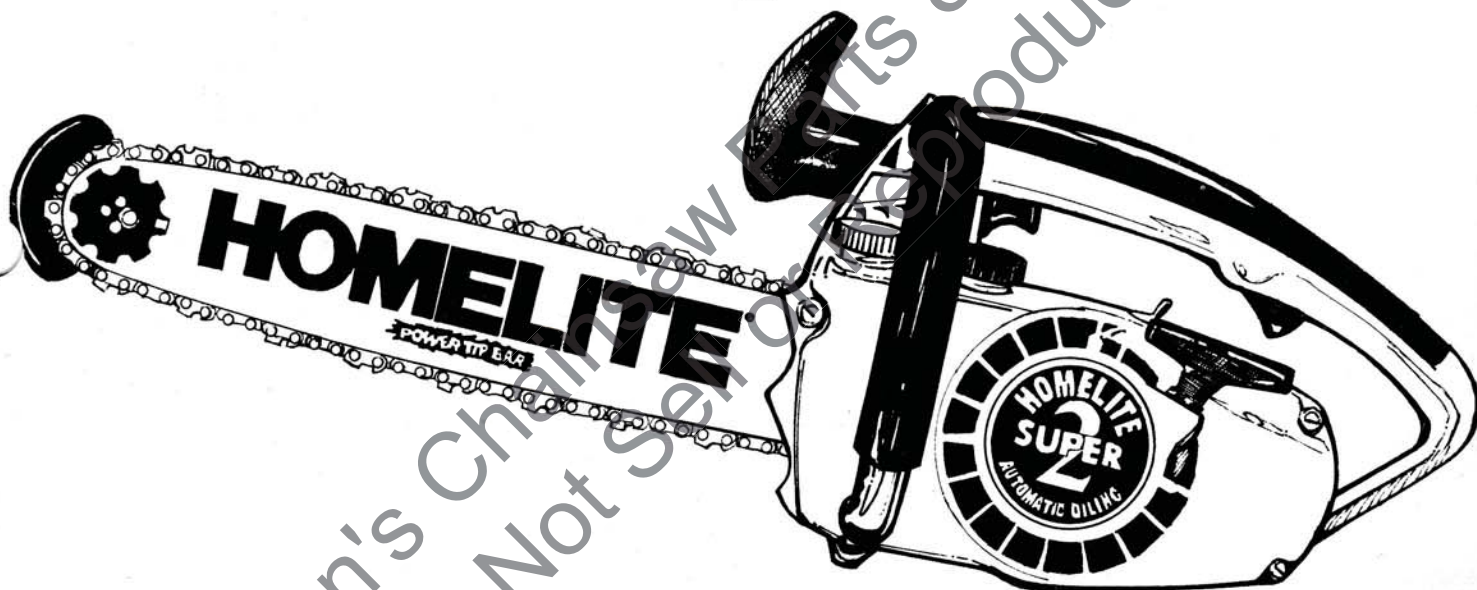

Automatic Oiling
CHAIN SAW

HOMELITE TEXTRON

Homelite Division of Textron Inc.

SUPER 2

FIGURE 1

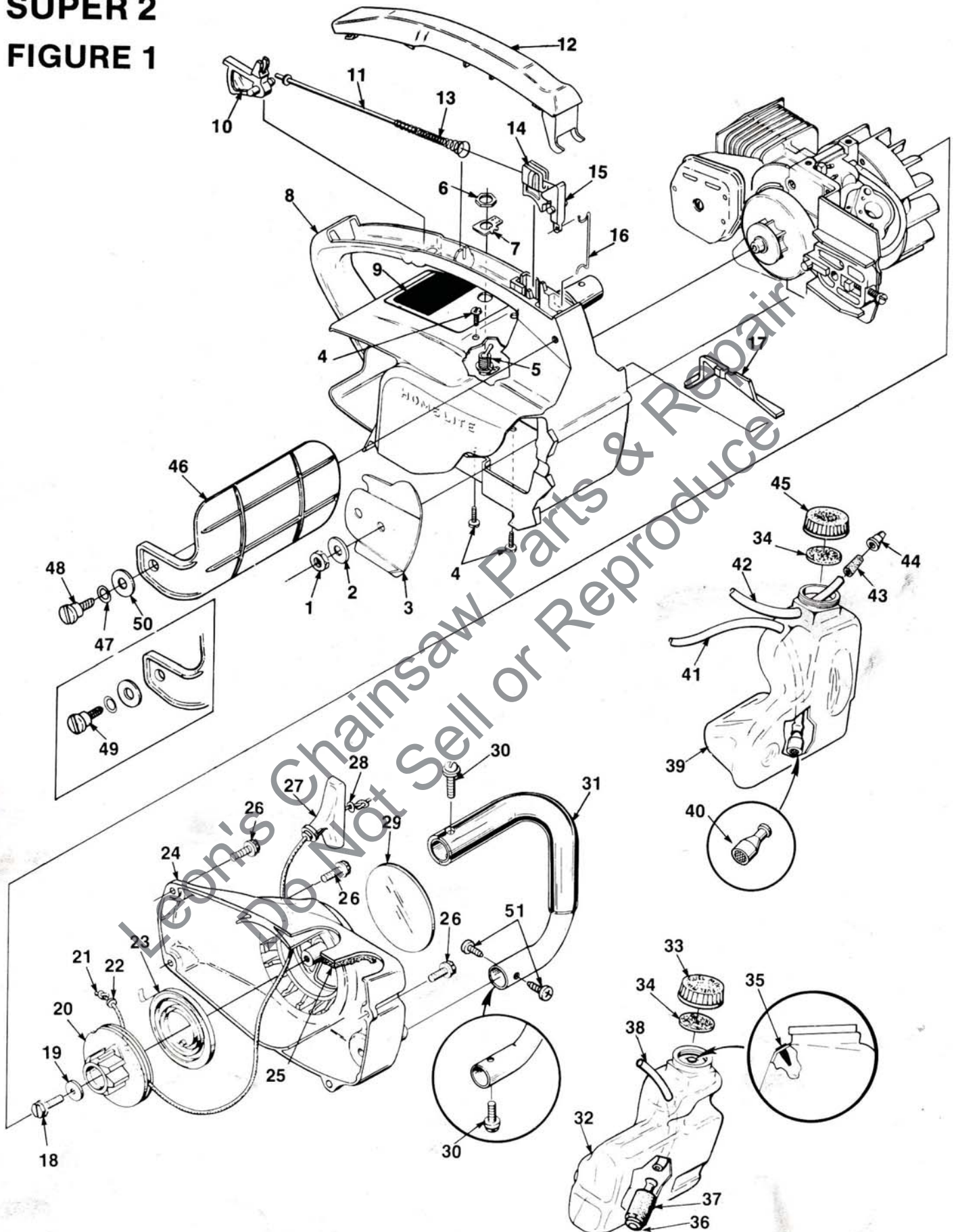

SUPER 2

FIGURE 1

NO.	DESCRIPTION	PART NO.	QTY.	NO.	DESCRIPTION	PART NO.	QTY.
1	NUT- Guide bar 1/4-28	81065-2	1	35	VALVE- Check (duck bill)	69451	1
2	WASHER- Flat	69309-A	1	36	FILTER- Fuel	A-69923	1
3	PLATE- Guide bar	69360-1	1		Includes:		
4	SCREW- Pan hd., 10-24 x 1/2	96620	4	37	ELEMENT- Felt	64083	1
5	SWITCH- Stop (grounding)	A-63938	1	38	LINE- Fuel 7 1/4"	70310-29	1
	Includes:			39	TANK- Oil	A-70898-A	1
6	NUT- Hex	72084-A1	1		Includes:		
7	PLATE- "On-Off"	70834	1	40	FILTER- Oil	A-68593	1
8	HOUSING- Engine	A-69882-B	1	41	LINE- Oil 6"	70309-24	1
	Includes:			42	LINE- Pressure	A-69358-B	1
9	PLATE- Starting instruction	70835	1		Includes:		
10	TRIGGER- Rear	69106-A	1	43	CONNECTOR- Oil	69659-B	1
11	ROD- Throttle	A-69136	1	44	VALVE- Check (duck bill)	69451	1
12	COVER- Handle	69140-A	1	45	CAP- Tank (off) (black)		
13	SPRING- Throttle rod	69249	1		(Note 1)	A-70893-B	1
14	TRIGGER- Front	69105	1		Includes:		
15	LEVER- Throttle	69107	1		GASKET- Fuel filler cap		
16	ROD- Throttle (front)	69255-C	1		(Note 2) (See 34)	94838-A	1
17	COVER- Air filter	69263	1	46	GUARD- Hand (Note 3)	A-70796-B	1
18	SCREW- Hex washer hd.				Includes:		
	10-32 x 5/8 (Magnesium Housing)	80704	1	47	WASHER- Curved spring	95694	1
	SCREW- Thread forming			48	SCREW- Shoulder self tapping		
	13/64 x .750 (Plastic housing)	94565	1	49	(10-32) (Magnesium housing)	95713	1
19	WASHER- Flat (Magnesium housing)	63606-1	1		SCREW- Shoulder		
	WASHER- (Plastic housing)	94062	1		#10 thread forming (Plastic housing)	95714	1
20	PULLEY- Starter	69158-A	1	50	WASHER- Flat	96102	1
	PULLEY- Starter (alternate)	94562-A	1	51	SCREW- Pan hd.,		
21	ROPE- Starter #4, 34" long	A-93874-A	1		#8 x 1/2 (Plastic housing)	82348	2
	Includes:						
22	WASHER- Nylon	93862	1				
23	SPRING- Rewind	69217	1				
24	HOUSING- Rewind starter						
	(Plastic housing)	A-94241	1				
	HOUSING- Rewind starter						
	(Magnesium housing)	A-69540	1				
	Includes:						
25	FILTER- Fuel tank valve	69443	1				
26	SCREW- Hex 10-32 x 5/8	80704	4				
27	GRIP- Starter rope	70211	1				
28	WASHER- Flat	84025	1				
29	DECAL- Super 2	70240	1				
30	SCREW- Pan washer hd.						
	10-32 x 5/8 (Magnesium housing)	82239	2				
31	HANDLE BAR (Magnesium housing)	A-70219-A	1				
	HANDLE BAR (Plastic housing)	A-94971	1				
32	TANK- Fuel	A-70899-A	1				
	Includes:						
33	CAP- Tank fuel (red)						
	(Note 1)	A-70894-B	1				
	Includes:						
34	GASKET- Fuel filler cap						
	(Note 2)	94838-A	1				

NOTE 1: Tanks with internal threads require A-70445 Fuel cap and A-70446 oil cap. If internal threads in tank are worn order new external threaded tank.

NOTE 2: Use 70826 Gasket in A-70893 and A-70894 external thread caps. Use 69585 gasket for caps with internal threads.

NOTE 3: For units with steel handguard, requires 70728 belle-ville washer and 70748 spacer, 80572 screw 10-32 x 5/8 (magnesium housing).

SUPER 2

FIGURE 2

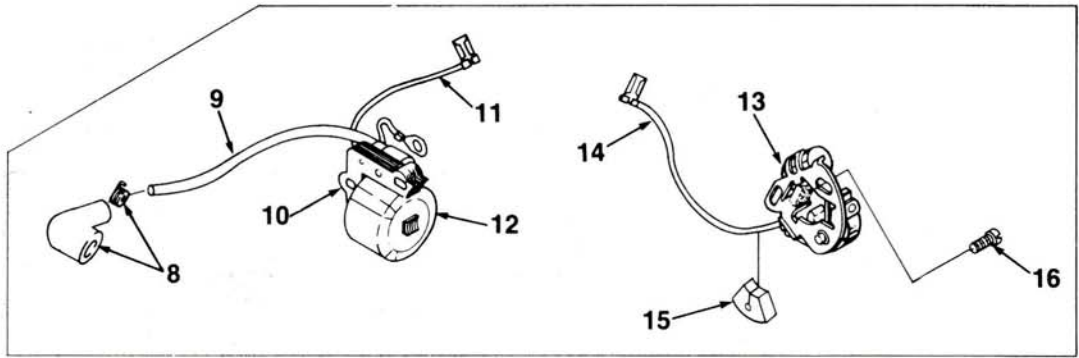

NOTE 1

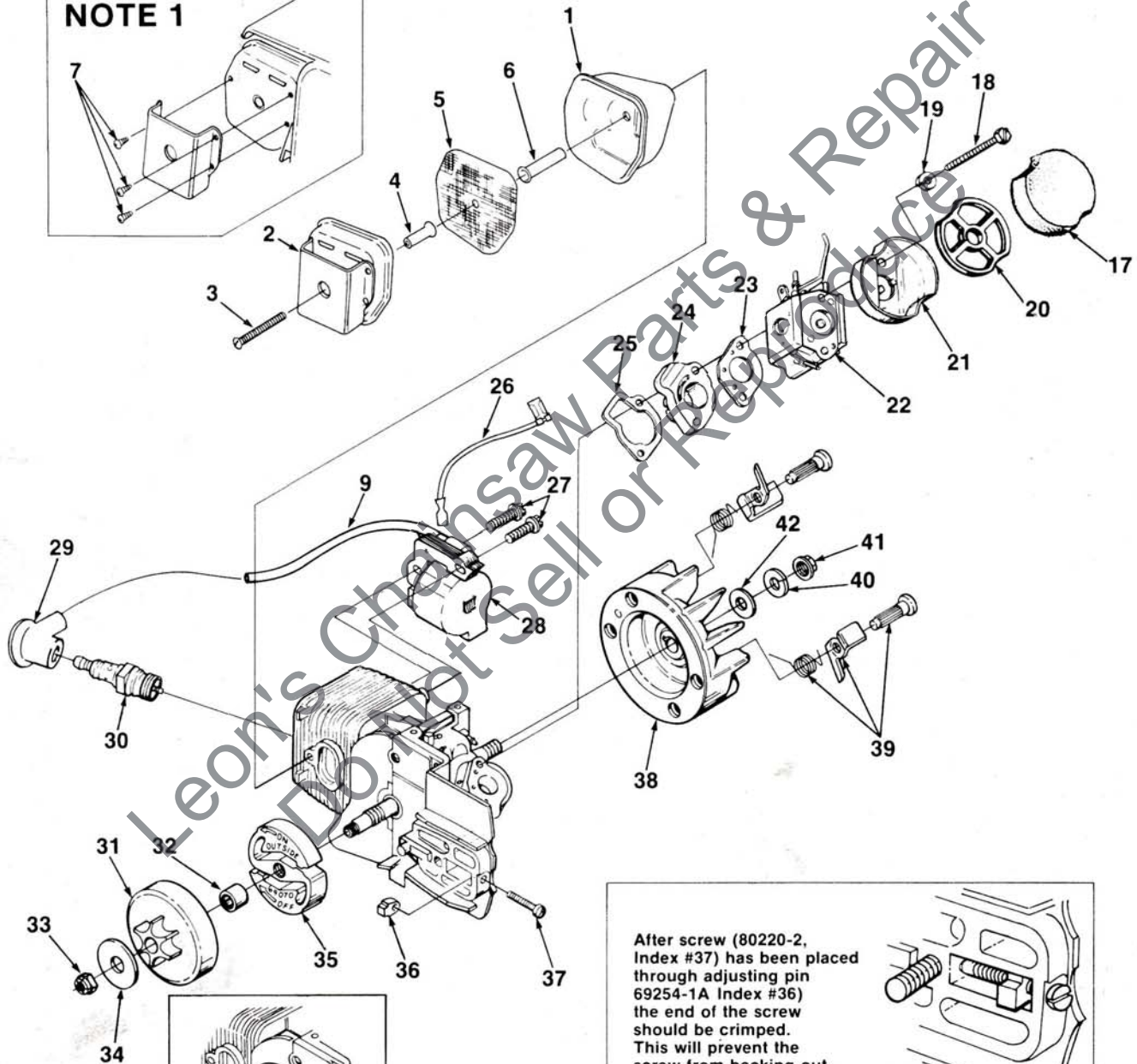
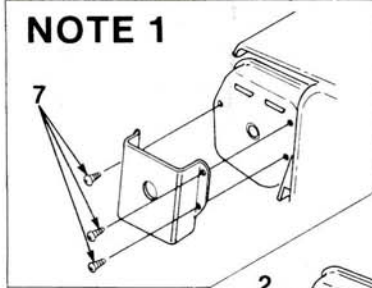

NOTE 5

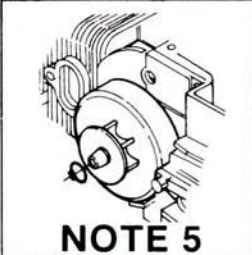

After screw (80220-2, Index #37) has been placed through adjusting pin 69254-1A Index #36) the end of the screw should be crimped. This will prevent the screw from backing out.

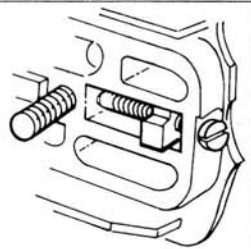

SUPER 2 FIGURE 2

NO.	DESCRIPTION	PART NO.	QTY.	NO.	DESCRIPTION	PART NO.	QTY.
1	MUFFLER	A-94051-B	1	28	MODULE- Ignition (solid state)	94711	1
	Includes:				Includes:		
2	CAP- Muffler (w/shield) (Note 1)	A-95428	1	29	LEAD- High tension (see index #9)	69326	1
	SPARK ARRESTOR	A-94139	1		TERMINAL- Spark plug (solid state) (Note 3)		1
	Includes:			30	SPARK PLUG- Champion DJ-7J	68616-S	1
3	SCREW	82320	1	31	SPROCKET & DRUM (Standard) (6 tooth 37 and 37.5 chain)	A-70221-C	1
4	SPACER- (Short)	93989	1		Includes:		
5	SCREEN- Spark arrestor	D-93991	1	32	BEARING- Needle	68512	1
6	SPACER- (Long)	93990	1	33	NUT- Locking 6/16 - 24 (Note 5)	81112	1
7	SCREW- 4 x .250 (Note 1)	82342	3	34	WASHER- thrust (clutch)	95299	1
8	TERMINAL- Spark plug	A-33055	1	35	CLUTCH- "S"	A-70351-A	1
9	LEAD- High tension (Note 2)	69326	1	36	PIN- Adjusting (see insert)	69254-1A	1
10	CORE- Coil (Point ignition)	69324	1	37	SCREW- Adjusting (fil. hd. 8-32 x 1) (See insert)	80220-2	1
11	LEAD- Stop switch (Point ignition)	A-95051	1	38	ROTOR & STARTER PAWL (Solid state (Phelon))	A-94717-A	1
12	COIL- Ignition (Point ignition)	69323	1		ROTOR & STARTER PAWL (Point ignition) (Phelon)	A-69297-B	1
	RETAINER- Coil (not shown) (Point ignition)	69325	1		Includes:		
13	POINT SET- Breaker (point ignition)	A-69336	1	39	KIT- Starter pawl (Note 4)	A-70285-C	1
	Includes:			40	WASHER- Lock	83002	1
14	LEAD- Electrical	70249	1	41	NUT- Rotor 5/16-24	81117	1
15	SEAL- Lead (point ignition)	69247	1	42	WASHER- Flat	84065-1	1
16	SCREW- Point set (point ignition)	88026	2				
17	FILTER- Air	69141	1				
18	SCREW- Hex hd. 10-32 x 2 1/4	80481	2				
19	WASHER- Lock #10	83006-1	2				
20	RETAINER- Air filter	69457	1				
21	CUP- Air filter	69148	1				
22	CARBURETOR- HDC-65 (walbro)	A-94649-A	1				
	CARBURETOR- Zama (C2S-H5)	A-96481	1				
23	GASKET- Carburetor	65016	1				
24	MANIFOLD- Intake	A-69373-A	1				
25	GASKET- Intake manifold	69143	1				
26	LEAD- Ground (solid state)	A-94721	1				
27	SCREW- Hex w/washer (8-32 x 3/4)	82248	2				

NOTE 1: Units with separate shield requires index #7 screws. All new muffler caps A-95428 includes a shield welded to cap.

NOTE 2: For Solid State ignition cut wire to 6 1/2".

NOTE 3: Use A-33055 for service replacement.

NOTE 4: Replacement starter pawl kit., item #39 includes an oversized pin, paint, stamp or mark to identify oversized pin when installing. Oversize pin can be installed tightly only once. If oversize pin is removed, the entire rotor assembly must be replaced.

NOTE 5: Retaining ring 93972 required for crankshafts without threaded clutch end.

SUPER 2

FIGURE 3

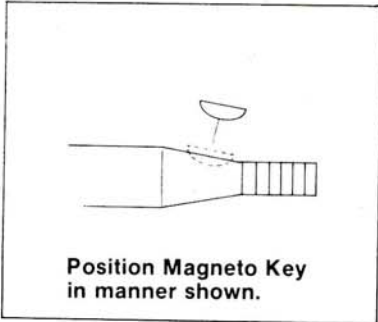
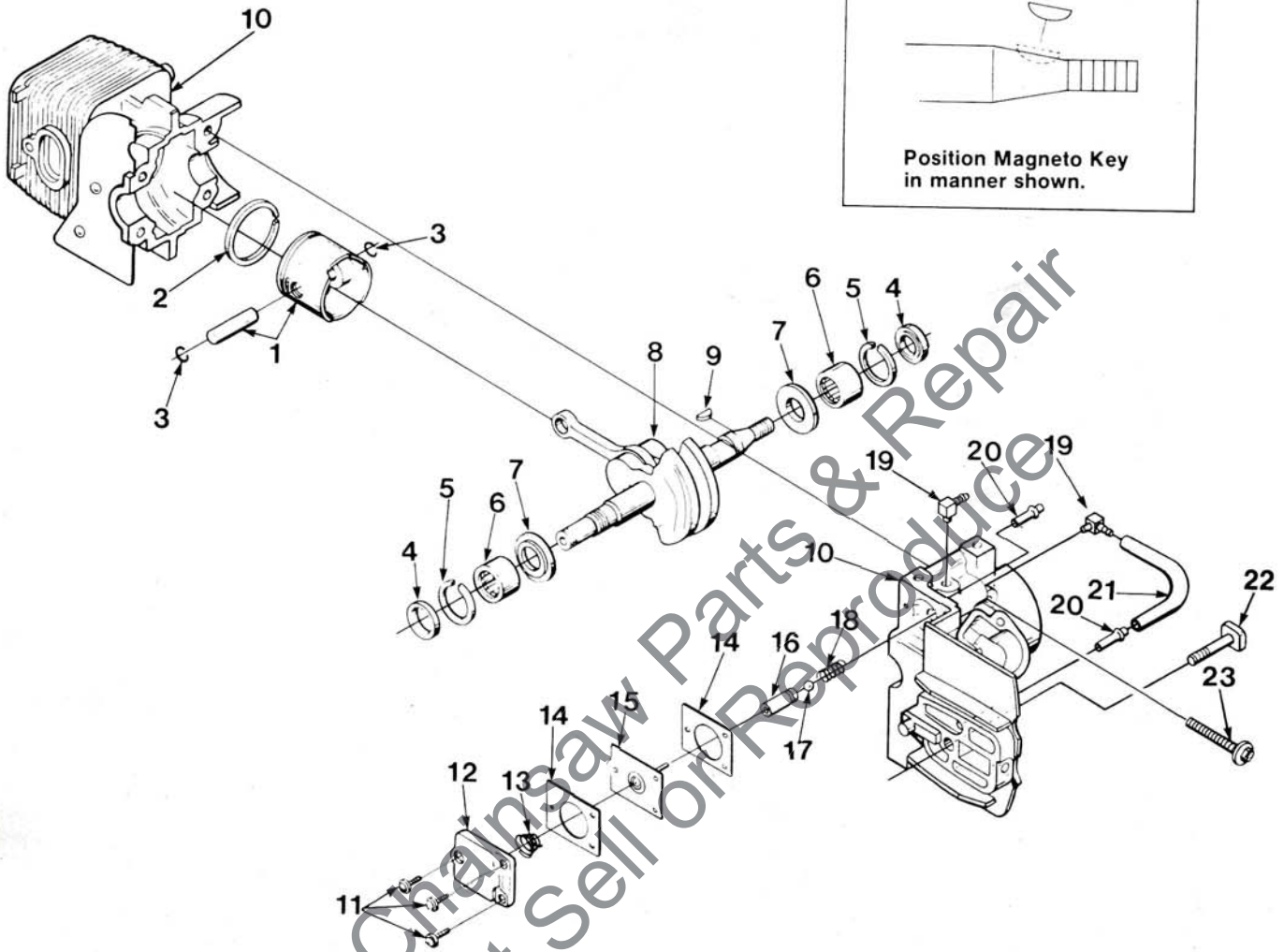

NO.	DESCRIPTION	PART NO.	QTY.	NO.	DESCRIPTION	PART NO.	QTY.
1	PISTON & PIN Includes:	A-70224-A	1	12	COVER- Oil pump	69224-1C	1
2	PISTON RING	70205	1	13	SPRING- Oil pump	69447	1
3	RING- Piston pin retaining	65261	2	14	GASKET- Oil pump	69244-1	2
4	SEAL	94638	2	15	PLUNGER- Oil pump	A-12356-B	1
5	SPACER- Seal	69407	2	16	BODY- Oil pump	69343-1	1
6	BEARING- Needle	12530	2	17	BALL- Check valve	60051	1
	BEARING- Needle (opt.)	68513	2	18	SPRING- Check valve	68570	1
7	WASHER- Thrust	69093-B	2	19	FITTING- Oil line	70204	2
8	CRANKSHAFT (C/D Ignition)	A-96384	1	20	FITTING- Tube	69833	2
	CRANKSHAFT (point ignition)	A-96385	1	21	LINE- Oil	70161	1
	Includes:			22	BOLT- Guide bar	69195	1
	NUT (Not shown)	81112	1	23	SCREW- Sem hex hd. 8-32 x 1	88044	4
9	KEY- Magneto (see above)	69250	1				
10	CYLINDER & CRANKCASE (C/D)	A-95072	1				
	CYLINDER & CRANKCASE (point ignition)	A-70226	1				
	Includes:						
11	SCREW- Pan hd., 6-32 x 3/8	80571	3				

**CARBURETOR
A-94649-A
HDC-65**

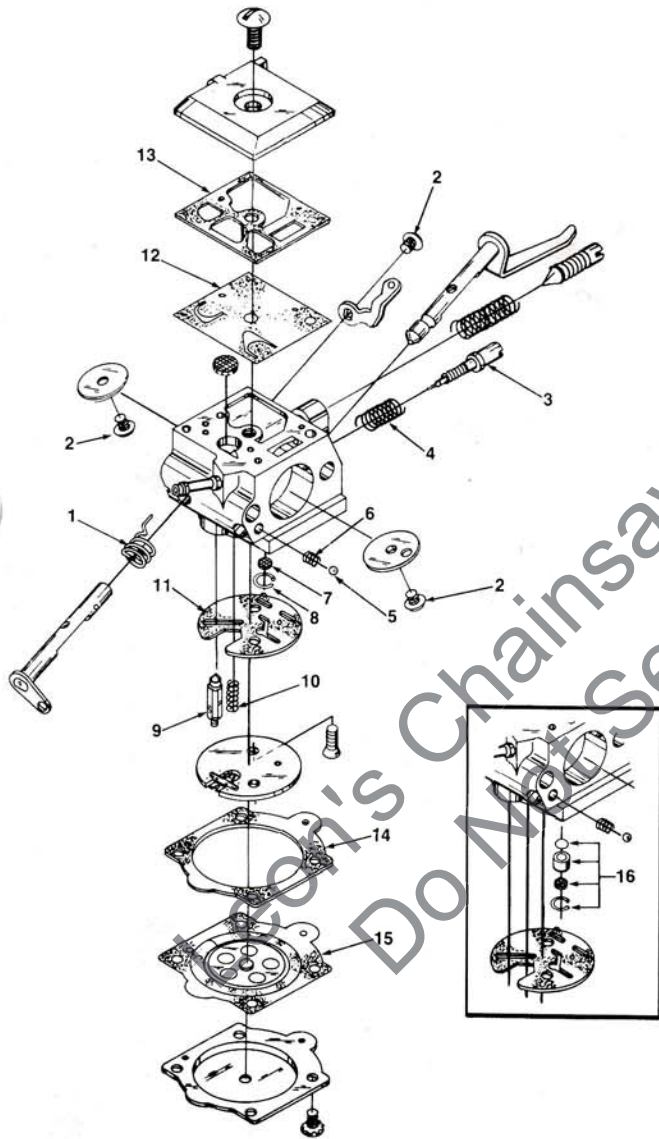

- 94056 Repair Kit (Includes 1-15)
- 94701 Gasket/Diaphragm Kit (Includes 11-15)
- 93910-A Check valve repair kit (16)
- 93199 Circuit Plate- High altitude .029 not shown
- 9229 Valve- Inlet needle (9)

**CARBURETOR
A-96481 (ZAMA)
C2S-H5**

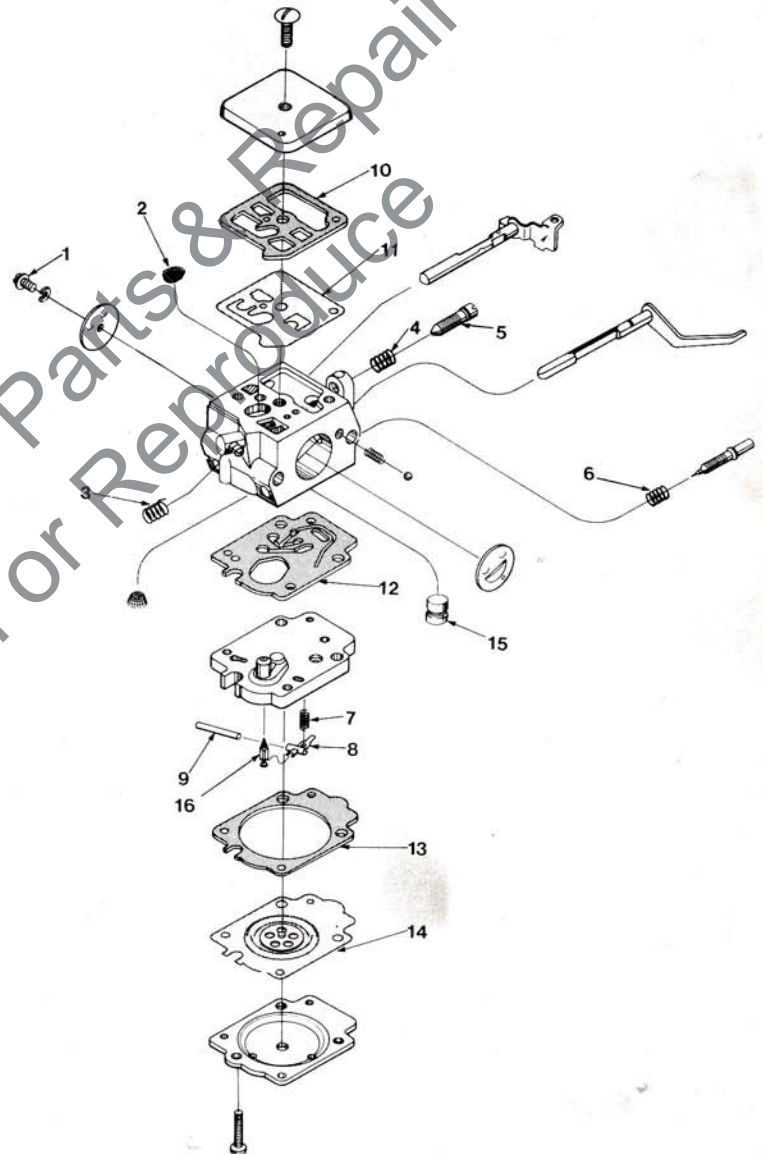

- 96484 Repair Kit (1-16)
- 96485 Diaphragm/Gasket Kit (10-14)

ACCESSORIES

GASKET- Oil pump body (repair)	69596
KIT- Repair (sprocket nose bar)	A-70239-B
KIT- Spark arrestor (use with A-93686 muffler and A-69253-1 muffler)	A-69586-B
LINE- Fuel (10 ft. length)	70310-99
LINE- Oil (10 ft. length)	70309-99
SAFE•T•TIP (standard)	A-70776-A
Includes:	
SCREW (Special)	93695
GREASE- Multi-use	
(Sprocket bearing - PT guide bar)	17193
CARRYING CASE	94215-A
STARTING ROPE- 250 ft. reel #4	68848

TOOLS

SILASTIC (crankcase sealing)	24823
PLIERS- Tru-Arc (sprocket retaining ring)	17198
PULLER- Magneto rotor	A-24747-A
Includes:	
BOLT- 5/16-18 x 1 3/4 (1)	80288
NUT- Hex 5/16-18 (2)	81196
WRENCH- Spanner (clutch)	A-93791
Includes:	
PIN- Clutch spanner	23717-A
TOOL- Carburetor check valve installation	24972

HOMELITE DIVISION OF TEXTRON INC.

P.O. BOX 7047
14401 CAROWINDS BOULEVARD
CHARLOTTE, N.C. 28217

HOMELITE **TEXTRON**

Homelite Division of Textron Inc.