

PARTS LIST

MODEL 5-20 HOMELITE CHAIN SAW

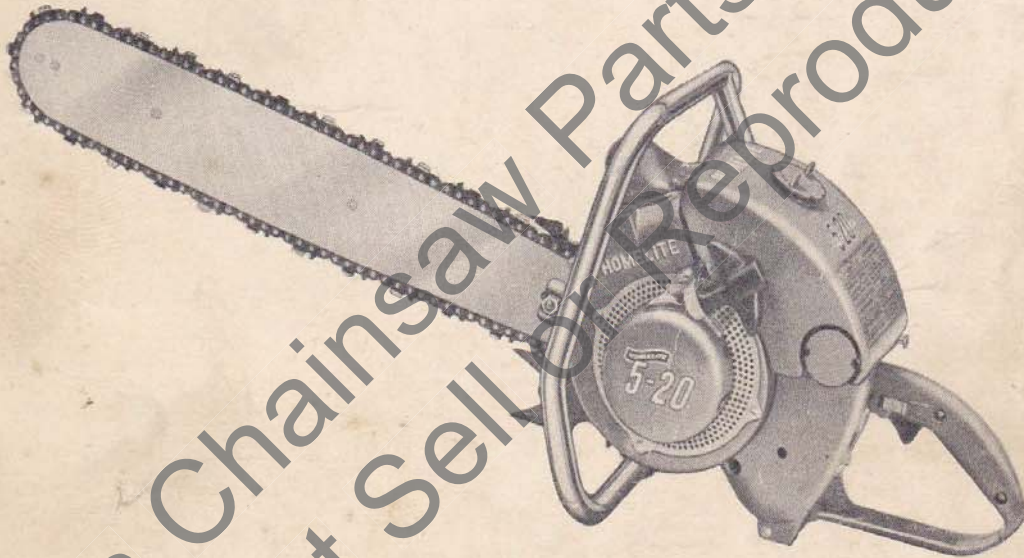

Gasoline-Engine-Driven

HOMELITE

a division of Textron Inc.
PORT CHESTER, N. Y.

RECOIL STARTER PARTS

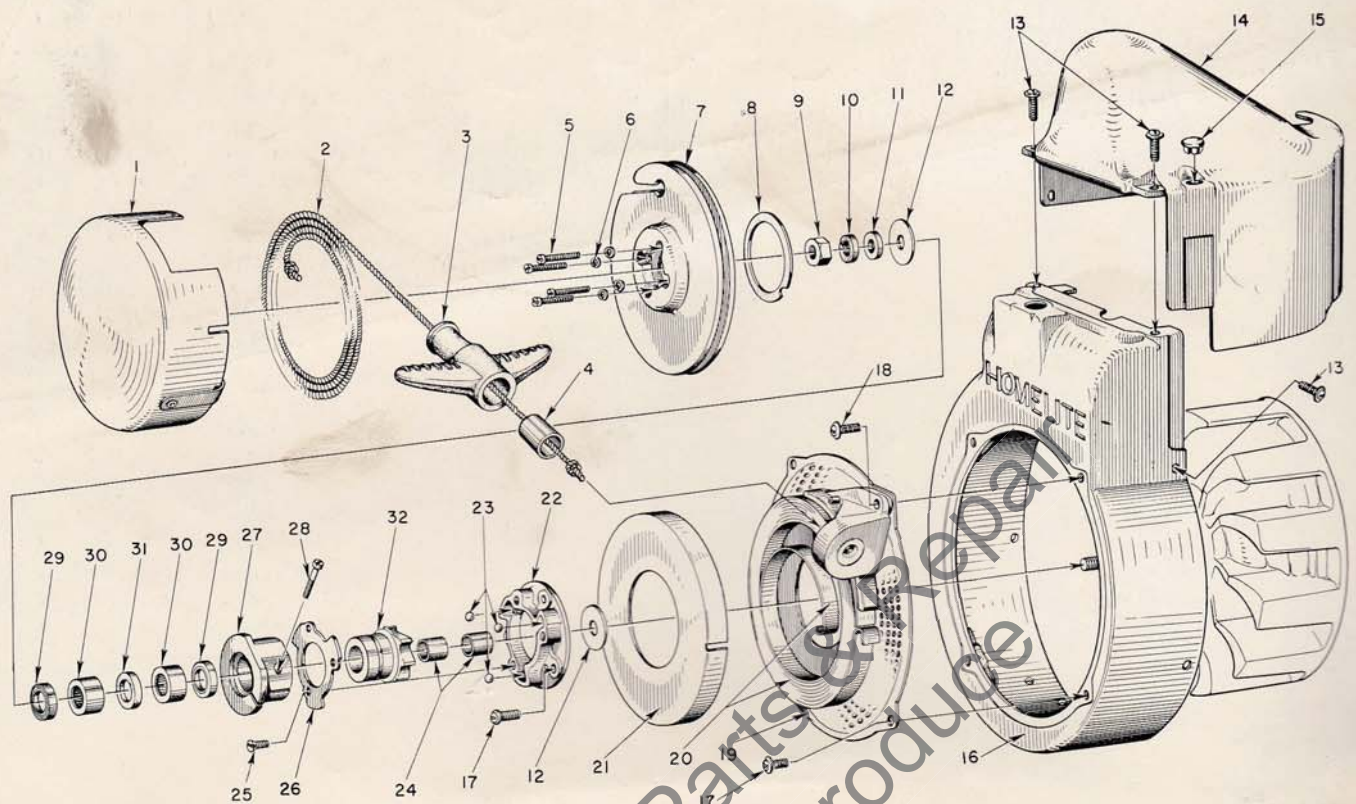

FIGURE 1

2

HOMELITE CHAIN SAW MODEL 5-20

PARTS LIST FOR FIGURE 1

Index No.	Part No.	Nomenclature	No. Required	Index No.	Part No.	Nomenclature	No. Required
1	AA-73234-1	COVER—pulley	1				
2	55898	ROPE—nylon	1	85073		RIVET—tubular	1
3	71149-B	GRIP—starting	1	20	71470-A	SPRING—recoil	1
4	55369-A	INSERT	1	21	71603	COVER—spring housing	1
5	80475	SCREW—6-32 x 3/8 fl. hd.	4		AA-55211-1	BALL DRIVE	1
6	83004	WASHER—#6 lock	4			Composed of	
7	AA-55223-A	PULLEY (with pin)	1	22	55054-A	PLATE—ball drive	1
8	71588	SHIM—plastic	as req'd.	23	55217	BALL	3
9	81124	NUT—3/8-24 hex jam	1	24	55584	SLEEVE—bearing	2
10	83018	WASHER—3/8 lock	1	25	80588	SCREW—5-40 x 5/16 flat hd.	3
11	84070	WASHER—3/8 flat alum.	1		AA-55212-1	RATCHET and HUB	1
12	55585	WASHER—thrust	2			Composed of	
13	80577	SCREW—8-32 x 3/8 pan hd.	7	26	55097	RETAINER	1
14	55015-B	SHIELD—cylinder	1		A-55342	HUB and SCREW	1
15	32814	PLUG—button	1			Composed of	
16	AA-55208	SHROUD—air	1	27		HUB	1
17	80579	SCREW—10-32 x 3/8 pan hd.	6	28	72295	SCREW—hub	1
18	80576	SCREW—10-32 x 1/8 pan hd.	1		AA-55213	RATCHET and BEARING	1
19	A-55580	SCREEN and BRACKET	1			Composed of	
		Includes		29	55272	SEAL—garlock	2
	AA-55222-A	BRACKET and BUSHING	1	30	55215	BEARING—needle	2
				31	55214	FELT	1
				32	A-55348	RATCHET (includes washer)	1
					**55271	WASHER—formica	1

* Not supplied separately

** Cemented to Ratchet

3

HOMELITE

IGNITION AND GOVERNOR PARTS

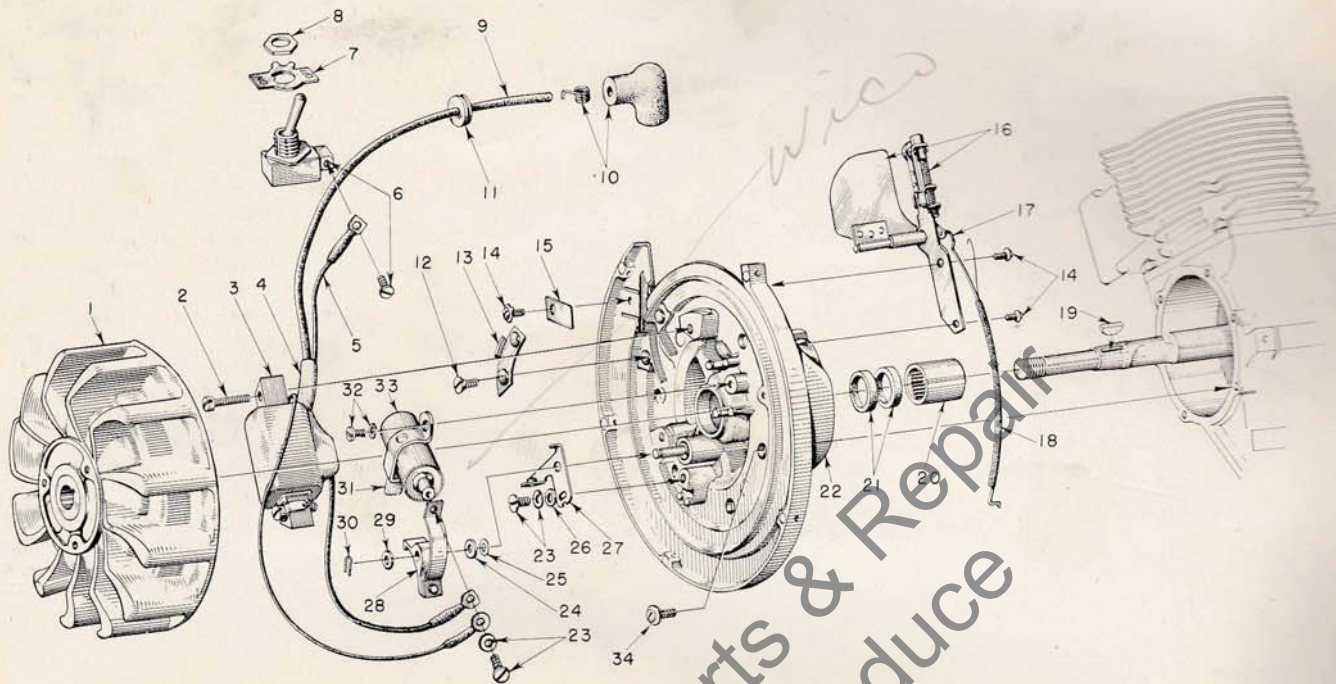

FIGURE 2

4

HOMELITE CHAIN SAW MODEL 5-20

PARTS LIST FOR FIGURE 2

Index No.	Part No.	Nomenclature	No. Required	Index No.	Part No.	Nomenclature	No. Required
1	55578	ROTOR	1	19	75078	KEY—rotor	1
2	30270	SCREW	2		A-55406	PLATE—back	1
	83046	WASHER—lock #10	2			Composed of	
3	55403	COIL	1	20	55204	BEARING—needle	1
4	55409	SLEEVE—insulating	1	21	71597	SEAL—garlock	2
5	55408	LEAD—ground	1	22	*	PLATE	1
6	AA-72094-A	SWITCH—"On-Off"	1	23	55411	SCREW—6-32 x 5/16 (with washer)	2
		Includes		24	55412	WASHER—contact plate	2
7	55879	PLATE (on-off)	1	25	30268	WASHER—spring	as req.
8	72084-A1	NUT	1	26	72484	WASHER—fixed contact plate screw	1
9	55407	LEAD—high tension	1		A-55402	POINTS (set)	1
10	A-55373	TERMINAL (sparky)	1			Composed of	
11	60929	GROMMET	1	27	*	PLATE—fixed contact	1
12	80598	SCREW—6-32 x 5/16 flat hd.	2	28	*	BREAKER ARM	1
13	55381	CLAMP—inner	1	29	28003	WASHER—breaker arm	1
14	80575	SCREW—8-32 x 1/4 pan hd.	3	30	28008	LOCK—spring	1
15	55161	CLAMP—outer	1	31	† 30267	WICK—felt	1
16	A-55796	GOVERNOR ASSEMBLY	1	32	30261	SCREW—8-32 x 5/16 (with washer)	1
		Includes		33	55399	CONDENSER	1
	84066	WASHER—governor arm burr	1	34	80576	SCREW—10-32 x 9/16 pan hd.	6
17	55735	GOVERNOR—arm	1				
18	55588	SPRING—governor	1				

* Not supplied separately

† Included with Points, A-55402.

FUEL TANK

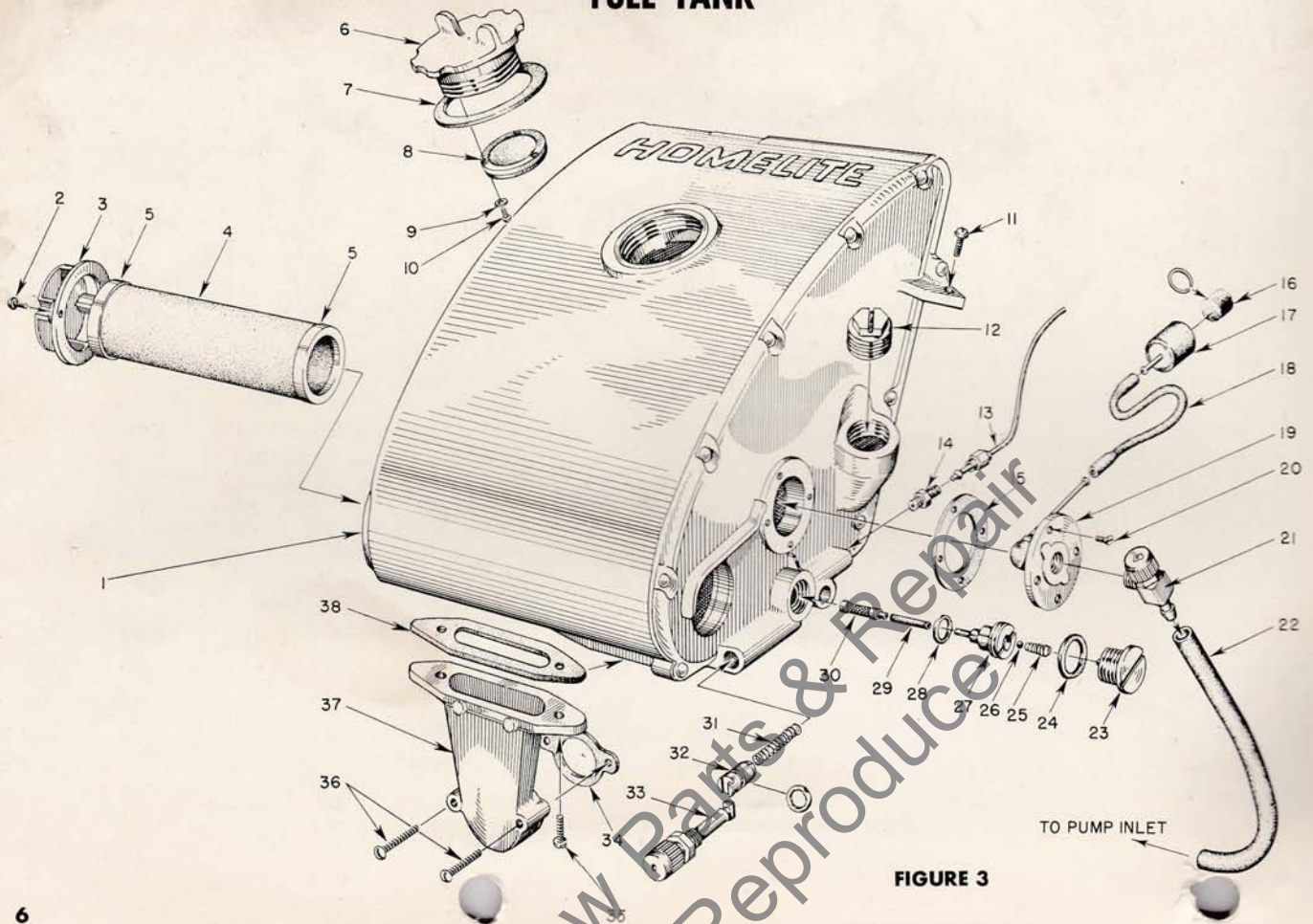

FIGURE 3

HOMELITE CHAIN SAW MODEL 5-20

PARTS LIST FOR FIGURE 3

Index No.	Part No.	Nomenclature	No. Required
1	A-55709	FUEL TANK—(includes air filter and cap)	1
	55729-A	DECAL—starting instructions	1
	55249	DECAL—Homelite	1
2	†80571	SCREW—6-32 x 3/8 pan hd.	2
3	†55066-A	CAP—air filter	1
4	†A-55531	FILTER—air	1
		Includes	
5	55530	GASKET	2
	A-55305	CAP—fuel	1
		Composed of	
6	*	CAP	1
7	72173	GASKET	1
8	A-55301-A	VALVE—relief	1
9	83083	WASHER—lock	3
10	80592	SCREW—3-48 x 1/4 rd. hd.	3
11	80582	SCREW—8-32 x 5/8 spin-lock	1
12	55140-A	CAP—oil	1
13	AA-55191	LINE—oil	1
14	A-55824	VALVE—check	1
15	72174	GASKET—outlet fitting	1
16	74374	†FILTER—felt	1

Index No.	Part No.	Nomenclature	No. Required
	†74380	SNAP RING	1
17	A-74375	BODY—fuel strainer	1
18	72107-A	SLEEVE—flexible	1
19	AA-72475	FITTING—fuel outlet	1
20	80451	SCREW—6-32 x 3/8 flat head	3
21	55738	VALVE—shut-off	1
22	A-55801	LINE—fuel	1
23	AA-55167	CAP—oil supply line	1
24	55107	GASKET	1
25	55288-A	SPRING—valve	1
26	25527	BALL—check	1
27	55109-A	SEAT—check valve	1
28	55110	GASKET	1
29	55133-A	SLEEVE—flexible	1
30	AA-55259-A	PICK-UP—oil	1
31	71762	SPRING—plunger	1
32	A-74406	PLUNGER TUBE (includes 74388 "O" Ring)	1
33	71764	PLUNGER—button	1
34	72971-1	GASKET—air elbow	1
35	80572	SCREW—10-32 x 5/8 spin-lock	2
36	80638	SCREW—10-32 x 1 1/4 spin-lock	2
37	55019-2	ADAPTER—air filter	1
38	55059	GASKET—adapter	1

†Included in Assembly A-74375

PISTOL GRIP AND THROTTLE PARTS

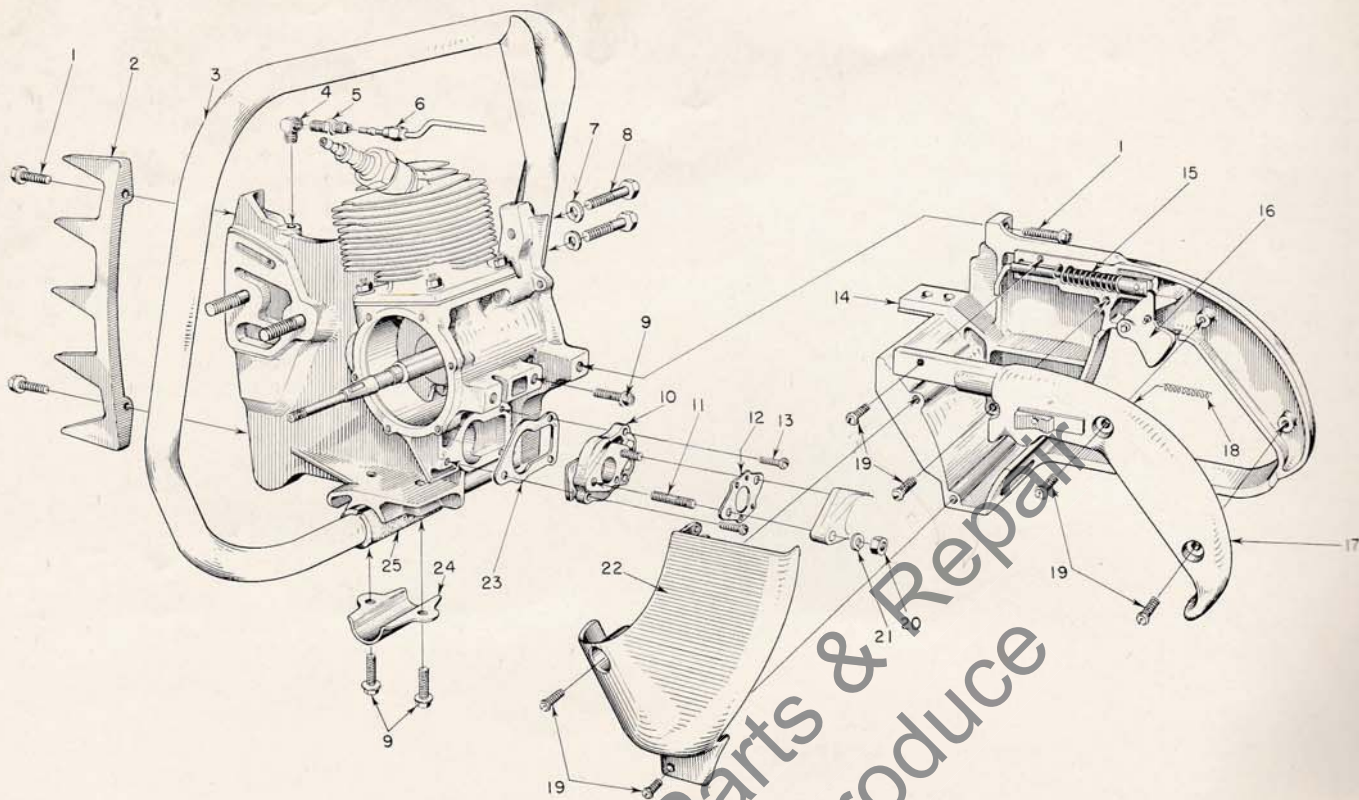

FIGURE 4

HOMELITE CHAIN SAW MODEL 5-20

PARTS LIST FOR FIGURE 4

Index No.	Part No.	Nomenclature	No. Required
1	80573	SCREW— $\frac{1}{4}$ -20 x $1\frac{1}{16}$ hex hd., spin-lock	5
2	55103	PLATE—bumper	1
3	A-55518	HANDLE—wrap-around (5-20)	1
	AA-55119	HANDLE—flush-cut (5-20A)	1
4	31734	ELBOW—connector	1
5	31733-1	ADAPTER—straight	1
6	AA-55191	LINE—chain oil	1
7	83003	WASHER— $\frac{3}{16}$ lock	2
8	80087	SCREW— $\frac{5}{16}$ -18 x $1\frac{1}{2}$ hex hd.	2
	28097	PLUG—pipe, $\frac{1}{8}$	1
9	80581	SCREW— $\frac{1}{4}$ -20 x $\frac{5}{8}$ hex hd., spin-lock	4
10	A-55800-A	ADAPTER—reed valve	1
11	27464	STUD (included in A-55800-A)	2
12	55553	GASKET—carburetor	1
13	80583	SCREW—10-32 x $\frac{3}{4}$ pan hd.	3
14	AA-55281	GRIP—pistol	1
15	A-55737	ROD—throttle	1
		Composed of	
	55045-A	SPRING	1

Index No.	Part No.	Nomenclature	No. Required
16	AA-55207	TRIGGER	1
17	AA-55228	COVER—grip	1
		Includes	
	AA-55282	LOCK—throttle	1
		Includes	
18	72970	SPRING—lock	1
19	80560	SCREW—8-32 x $\frac{1}{2}$ pan hd.	7
20	81013	NUT— $\frac{1}{4}$ -20 hex	2
21	83009	WASHER— $\frac{1}{4}$ lock	2
22	55104	SHIELD—carburetor	1
23	55116	GASKET—reed valve adapter	1
24	55145	CLAMP—handle	1
25	55146	CUSHION—handle	1
	A-55740	BRACE—handle	1

CARBURETOR PARTS

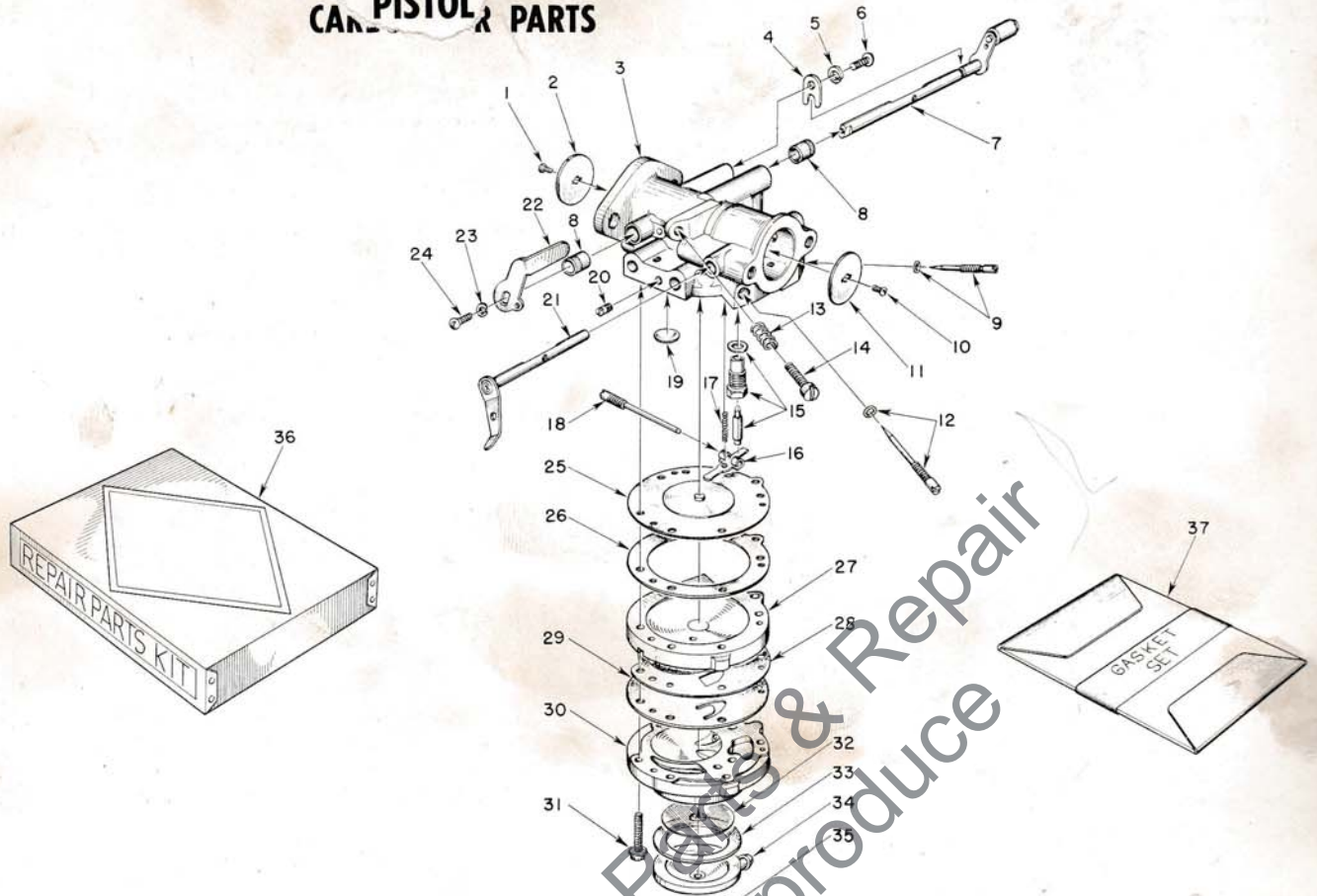

FIGURE 5

HOMELITE CHAIN SAW MODEL 5-20

PARTS LIST FOR FIGURE 5

Index No.	Part No.	Nomenclature	No. Required	Index No.	Part No.	Nomenclature	No. Required
	A-55786	CARBURETOR	1		55344	GASKET—inlet seat	1
		Includes		16	†55747	LEVER—inlet control	1
		"O" ring	1	17	†55759	SPRING—control lever	1
1	†71519	SCREW—throttle shutter	1	18	†A-55762	SCREW—pinion	1
2	73272	SHUTTER—throttle	1	19	30818	PLUG	1
3	A-55769	BODY—service	1		55763	PLUG—body channel	1
4	73086	CLIP—throttle shaft	1	20	28091	PLUG—drain	1
5	83000	WASHER—lock #8	1	21	A-55766	LEVER—choke	1
6	73088	SCREW—8-32 x 3/16 rd. hd.	1	22	55734	LEVER—throttle stop	1
7	A-55819	SHAFT—throttle	1	23	†71522	WASHER—lock #4	1
8	72812	BUSHING—throttle shaft	2	24	†71521	SCREW—4-36 x 1/4 rd. hd.	1
9	†A-55768	SCREW—main adjustment (high speed)	1	25	†A-55760	DIAPHRAGM—main	1
		Includes		26	55754	GASKET—main diaphragm	1
		"O" ring	1	27	55749	COVER—main diaphragm	1
10	28049	SCREW—choke shutter	1	28	55881	GASKET—fuel pump	1
11	73263	SHUTTER—choke	1	29	†55753	DIAPHRAGM—pump	1
	73264	SPRING—choke friction pin	1	30	55748	BODY—pump	1
	71494	PIN—choke friction	1	31	55316	SCREW and WASHER	6
12	†A-55767	SCREW—idle adjustment (low speed)	1	32	†55752	SCREEN—fuel strainer	1
		Includes		33	55751	GASKET—pump cover	1
		"O" ring	1	34	55750	COVER—pump	1
13	†28064	SPRING—idle stop screw	1	35	55756	SCREW—retaining	1
14	†71509	SCREW—idle stop (speed control)	1	36	55837	REPAIR PARTS KIT	1
15	†A-55761	INLET NEEDLE and SEAT	1	37	†55836	GASKET SET	1
		Includes					

† Included in 55837 Repair Parts Kit

GEAR CASE AND SPROCKET PARTS

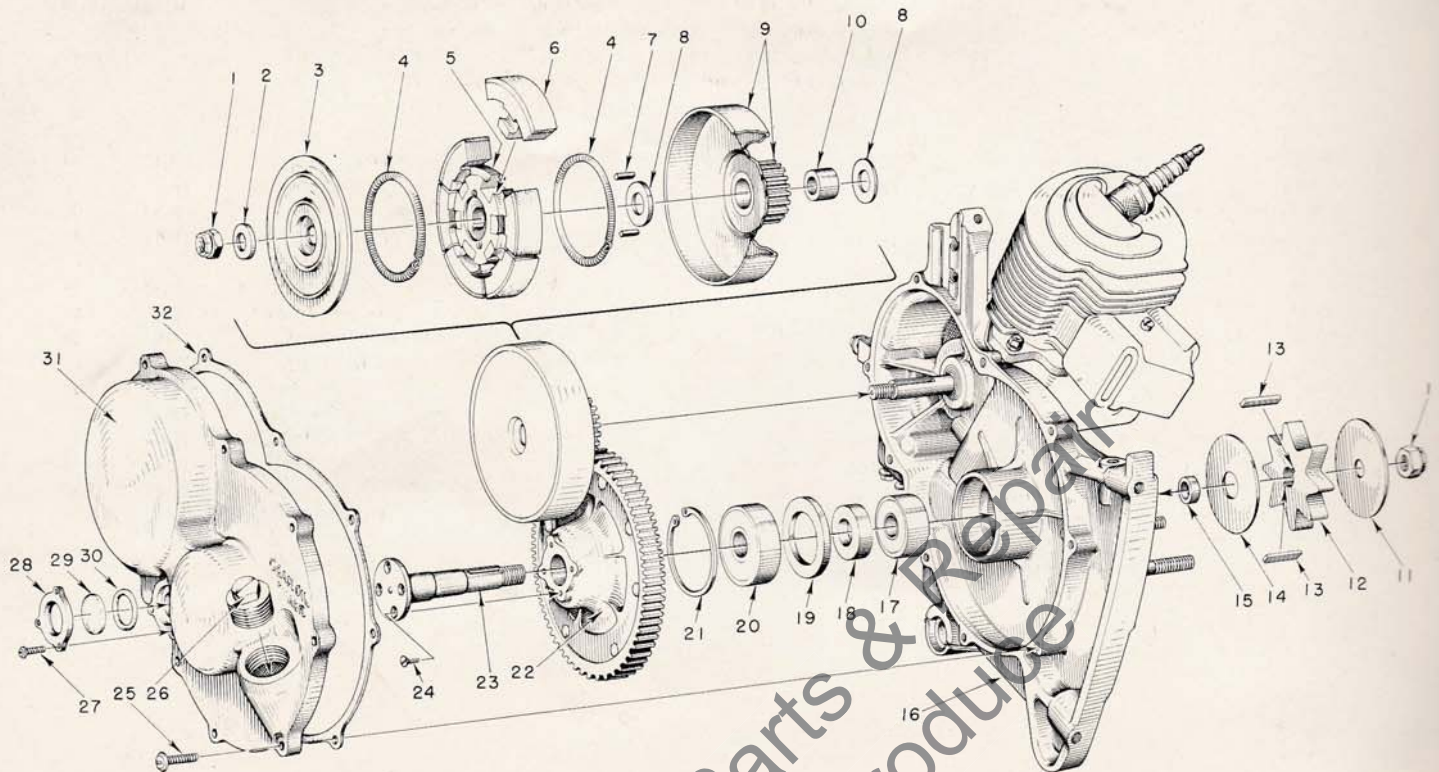

12

FIGURE 6

HOMELITE CHAIN SAW MODEL 5-20

PARTS LIST FOR FIGURE 6

Index No.	Part No.	Nomenclature	No. Required
1	81116	NUT— $\frac{3}{8}$ -24 flex-lock	2
2	55036	WASHER—clutch	1
3	55126	COVER—clutch	1
	A-55693	CLUTCH	1
		Composed of	
4	55123	SPRING	2
5	55075	SPIDER	1
6	A-55692	SHOE	6
7	55225	KEY—clutch	2
8	55034	WASHER—thrust	2
9	AA-55086	CLUTCH DRUM (and drive gear)	1
10	55035	BEARING—drive gear	1
11	55602	WASHER—sprocket (outer)	1
12	††55593	SPROCKET	1
13	55482-1	KEY—sprocket	2
14	55601	WASHER—sprocket (inner)	1
15	55586	SPACER—sprocket	1
16	**	CRANKCASE	1
17	55184	BEARING—ball	1

Index No.	Part No.	Nomenclature	No. Required
18	55024	SPACER—bearing	1
19	55025	SHOULDER—bearing	1
20	72040	BEARING—ball	1
21	28922	RING—retaining	1
22	AA-55068-2	DRIVEN GEAR	1
23	55005-C	SHAFT—sprocket	1
24	80651	SCREW—12-28 x $\frac{3}{8}$ flat hd., socket	4
25	80572	SCREW—10-32 x $\frac{5}{8}$ pan hd.	9
	AA-55226-A	COVER—gear case	1
		Composed of	
26	55140-A	PLUG—oil filler	1
27	80571	SCREW—6-32 x $\frac{3}{8}$ pan hd.	3
28	55098	PLATE—window	1
29	55099	WINDOW—plastic	1
30	55100	GASKET—"O" ring	1
31	*	COVER	1
	55730	DECAL	1
32	55053-A	GASKET—gearcase cover	1

* Not Supplied Separately

** A-55598—for breakdown see figure 7 Engine Parts

†† 6-tooth 55101-A Sprocket must be used for Clearing Attachment and for Bow Attachment in place of 8-tooth Sprocket.

The 6-tooth Sprocket must also be used for guide bars 33" or more in length.

ENGINE ASSEMBLY

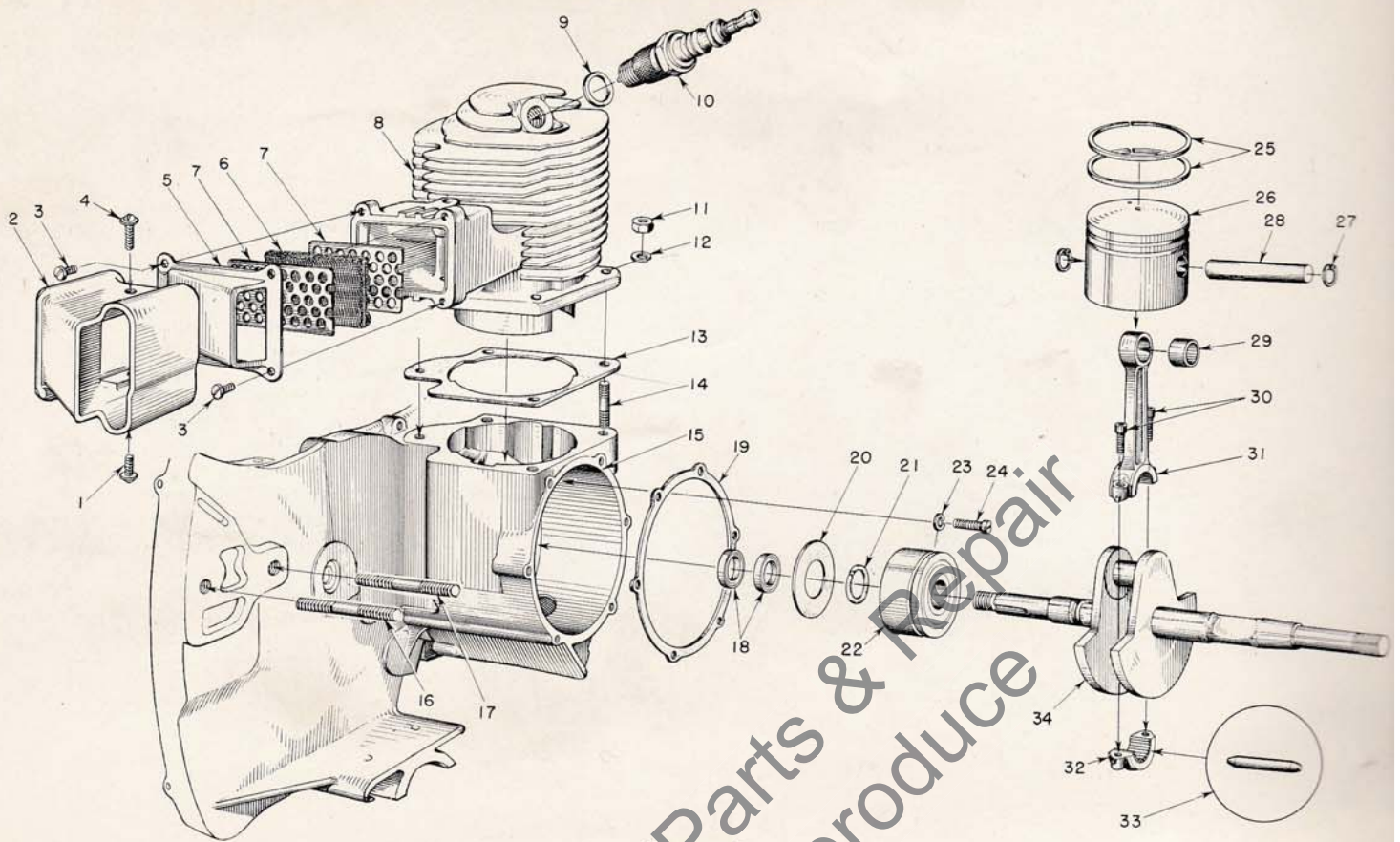

FIGURE 7

14

HOMELITE CHAIN SAW MODEL 5-20

PARTS LIST FOR FIGURE 7

Index No.	Part No.	Nomenclature	No. Required
1	80625	SCREW—10-32 x 1/2 pan hd.	1
2	55506-1A	DAMPER	1
3	80620	SCREW—6-32 x 1/2 pan hd.	4
4	80583	SCREW—10-32 x 3/4 pan hd.	1
5	55507	CAP—exhaust	1
6	55508	ELEMENT—muffler	1
7	55509	RETAINER—muffler element	2
8	55490	CYLINDER	1
9	25038	GASKET (included with spark plug)	1
10	71530	SPARK PLUG—Champion HO-8A	1
11	81065-2	NUT—1/4-28 hex	4
12	83009	WASHER—1/4 lock	4
13	55050-A	GASKET—cylinder	1
	A-55598	CRANKCASE	1
		Composed of	
14	55871	STUD	4
15	*	CRANKCASE and GEARCASE	1
16	55606	STUD—guide bar (long)	1
17	55056-D	STUD—guide bar (short)	1
18	71597	SEAL—garlock	2
19	55049	GASKET—back plate	1

Index No.	Part No.	Nomenclature	No. Required
20	55048	GASKET—crankcase sealing	1
21	55047	RING—bearing retaining	1
22	55193	BEARING—main	1
23	83061	WASHER—lock, special thin	2
24	19238-A	SCREW—main bearing retaining	2
25	55537	RING—piston	2
26	A-55599	PISTON and PIN	1
		Composed of	
	*	PISTON	1
27	55095	RING—piston pin retaining	2
28	*	PIN—piston	1
	AA-55195	CONNECTING ROD	1
		Composed of	
29	55196	BEARING—piston pin	1
30	80541	SCREW—8-32 x 1/2 allen cap	2
31	*	ROD	1
32	*	CAP	1
33	AA-55280	ROLLERS (set)	1
		Composed of	
	*	ROLLER—needle (see inset)	27
34	55514-A	CRANKSHAFT	1

* Not Supplied Separately

SAW PARTS

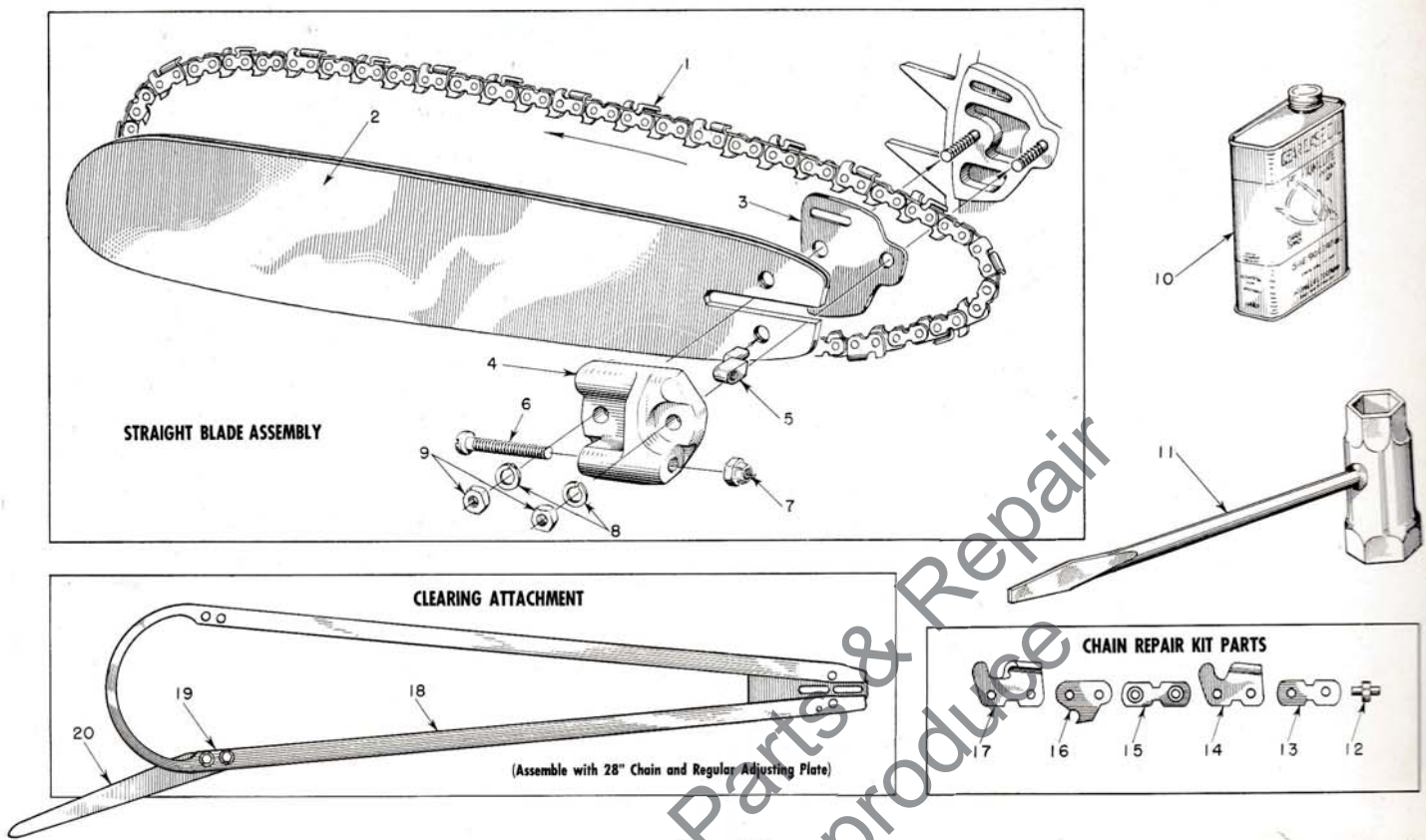

FIGURE 8

HOMELITE CHAIN SAW MODEL 5-20

PARTS LIST FOR FIGURE 8

Index No.	Part No.	Nomenclature	No. Required	
1	A-55338	14" CHAIN—#10 with kit	1	
	AA-73338	18" CHAIN—#10 with kit	1	
	A-55319	20" CHAIN—#10 with kit	1	
	AA-73340	23" CHAIN—#10 with kit	1	
	AA-73342	28" CHAIN—#10 with kit	1	
	AA-73344	†33" CHAIN—#10 with kit	1	
	AA-73346	†38" CHAIN—#10 with kit	1	
	AA-73350	†44" CHAIN—#10 with kit	1	
	AA-73597	†50" CHAIN—#10 with kit	1	
	AA-73598	†60" CHAIN—#10 with kit	1	
	2	A-55714	14" BAR—.063	1
		A-55718	18" BAR—hard track plus extra hard tip .063	1
A-55720		20" BAR—hard track plus extra hard tip .063	1	
A-55723		23" BAR—hard track plus extra hard tip .063	1	
A-55728		28" BAR—hard track plus extra hard tip .063	1	
55335-1		†33" BAR—extra hard tip .063	1	
55336-1		†38" BAR—extra hard tip .063	1	
55706-1		†44" BAR—extra hard tip .063	1	
55707-1		†50" BAR—extra hard tip .063	1	
55708-1		†60" BAR—extra hard tip .063	1	
3		55128	SHIM	1
		A-55591	ADJUSTING PLATE	1
4		55551-B	Composed of PLATE—adjusting	1
	55552	PIN—guide bar adjusting	1	

Index No.	Part No.	Nomenclature	No. Required
6	80617	SCREW— $\frac{3}{16}$ -18 x 2 round hd.	1
7	81123	NUT—hex lock	1
8	83018	WASHER—lock	2
9	81089	NUT— $\frac{3}{8}$ -16 hex	2
10	55291-A	OIL—gear (pint can SAE-90)	1
11	22808	WRENCH—combination	2
	AA-73314	KIT—chain repair	1
		Composed of	
12	72959	RIVET	4
13	72960	LINK—connecting (plain)	2
14	72963	CUTTER—right	1
15	AA-72961	LINK—connecting (w/rivets)	2
16	73383	LINK—drive	1
17	72964	CUTTER—left	1
	†A-55379	CLEARING ATTACHMENT	1
		Composed of	
18	A-55435	GUIDE—clearing	1
19	80604	SCREW—hex hd. $\frac{3}{16}$ -24 x $\frac{3}{4}$	2
20	73820	SPUR—plunging	1

* Also fits 14" bow attachment

** Also fits clearing attachment and 18" bow attachment

† Use 6-tooth, $\frac{1}{2}$ " pitch Sprocket 55101-A

PLUNGE CUT BOW ATTACHMENTS

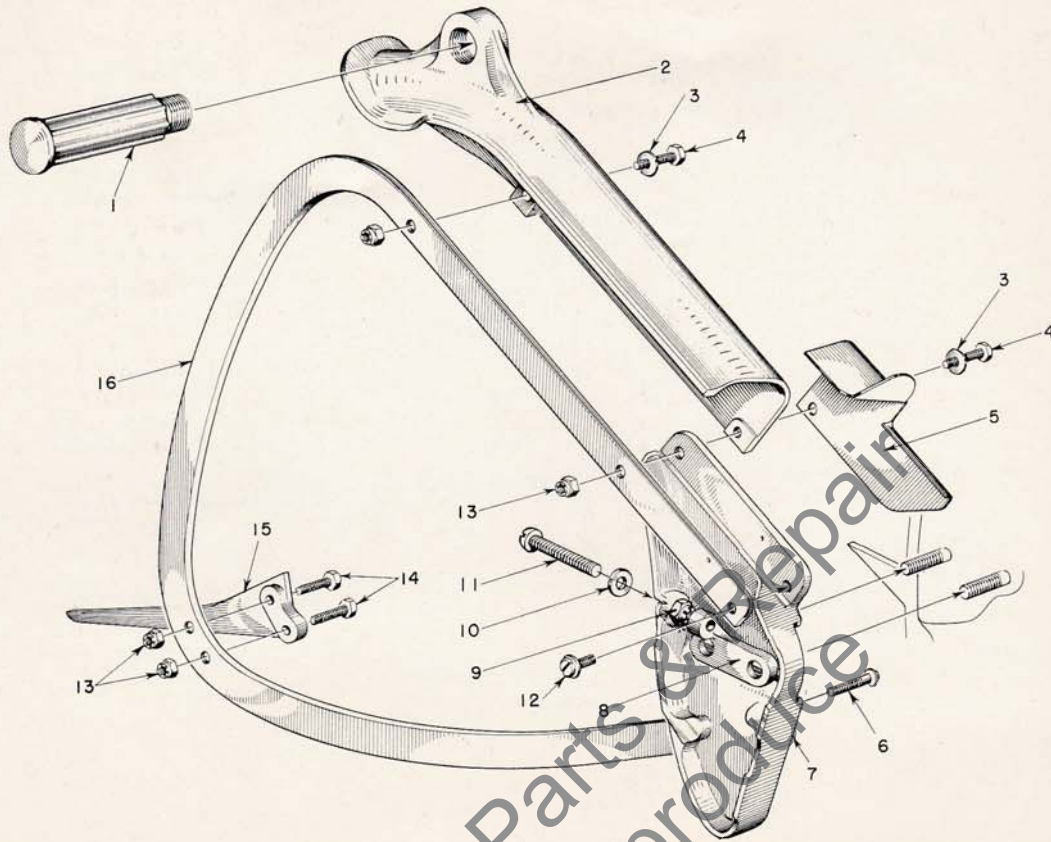

18

FIGURE 9

HOMELITE CHAIN SAW MODEL 5-20

PARTS LIST FOR FIGURE 9

Index No.	Part No.	Nomenclature	No. Required
	A-55487	†KIT—bow mounting	1
		Composed of	
1	72226	HANDLE	1
2	72779-1	GUARD—chain	1
3	84001	WASHER— $\frac{5}{16}$ flat	2
4	80559	SCREW— $\frac{3}{16}$ -24 x $1\frac{1}{2}$ hex hd.	2
5	55297	GUARD—chain	1
6	80593	SCREW— $\frac{3}{16}$ -18 x $\frac{3}{4}$ pan hd.	2
	A-55488	PLATE—bow mounting	1
		Composed of	
7	55248	PLATE—mounting	1
8	55253	PLATE—adjusting	1

Index No.	Part No.	Nomenclature	No. Required
9	81123	NUT—hex lock	1
10	84056	WASHER— $\frac{5}{16}$ flat	1
11	80617	SCREW— $\frac{3}{16}$ -18 x 2 rd. hd.	1
12	80590	SCREW— $\frac{5}{16}$ -18 x $\frac{1}{2}$ pan hd.	1
13	81112	NUT— $\frac{3}{16}$ -24 hex lock	4
14	80546	SCREW— $\frac{3}{16}$ -24 x $1\frac{1}{4}$	2
15	72784	SPUR—plunging	1
16	A-73739	14" GUIDE—chain (extra hard track)	1
	A-73740	18" GUIDE—chain (extra hard track)	1
	AA-73235	HELPER'S END (18" bow only)	1
		Composed of	
	72827	GUARD—end	1
	72226	HANDLE (same as index #1)	1

†Requires 6-tooth, $\frac{1}{2}$ " pitch Sprocket 55101-A

HOMELITE *Carryable* PRODUCTS

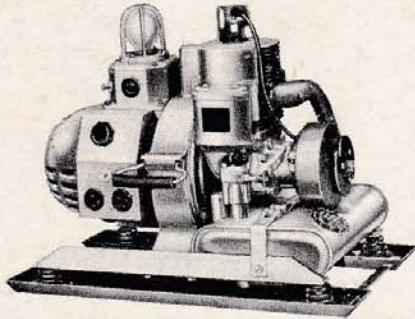

GENERATORS

Alternating or Direct Current
Gasoline-Engine-Driven
Sizes: 1000 to 5000 watts
Voltages: 6 to 220 volts
Frequencies: 50 to 400 cycles

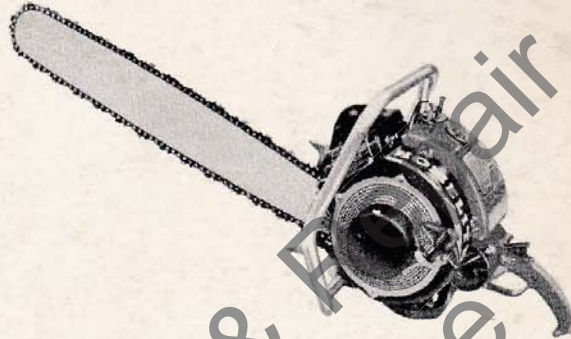

CHAIN SAWS

Gasoline-Engine-Driven
3 1/2 HP to 5 1/2 HP
Straight Blade and Bows
Brushcutters
Clearing Attachments

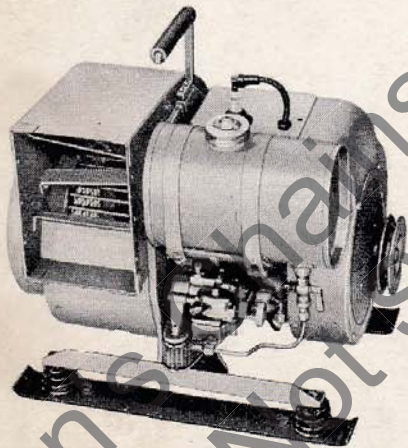

BLOWERS

Gasoline-Engine-Driven
Capacities: 1500 CFM

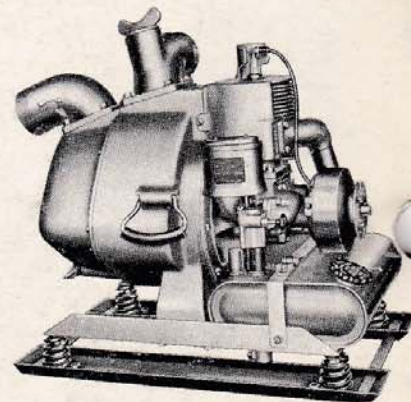

PUMPS

Diaphragm
Self-Priming Centrifugal
Gasoline-Engine-Driven
Sizes: 1 1/2", 2", 3"
Capacities: 5,500 to 15,000 gph

HOMELITE

a division of Textron Inc.
PORT CHESTER, N. Y., U.S.A.

