



TECHNICAL SERVICE BULLETIN

NO. 180-001

AFFECTS: 360-A0

SUBJECT: 70729 OIL SEAL

SUBJECT: NEW "DOUBLE LIP" SEAL 70729

In the past, two (2) seals (12282-A) were placed back to back and inserted into the crankcase. Now one (1) "double lip" seal 70729 is used to replace the two (2) single seals.

This new seal is used in the crankcase only. One (1) seal 12282-A is still required in the backplate.

When installing the seal, use seal installation tool 24826-A and seal assembly sleeve 23759. Position the seal with the lip toward the crankcase.

Please note in your 360 parts list 17080 Rev. 1 that this seal is now available.

Pete Romot
Technical Service Advisor

PR/gf

DATE 1-3-80



TECHNICAL SERVICE BULLETIN

NO. 180-002**AFFECTS:** CHAIN SAWS WITH SPARK ARRESTOR MUFFLER**SUBJECT:** SPARK ARRESTOR SCREENS

Many of our chain saws are being produced with spark arrestor mufflers as standard equipment. Included is a spark arrestor screen that limits the size of the hot carbon particles that can be discharged through the muffler. These hot particles could possibly cause brush or forest fires under certain conditions.

Trapped carbon particles can build up and cause a clogged spark arrestor screen. The first indication of a clogged screen would be lack of cutting power. Before checking the carburetor or ignition system, remove the muffler cap and check the spark arrestor screen. A carboned screen should either be cleaned or replaced. A heavily carboned screen could indicate an oil rich fuel mix or a carburetor that may be out of adjustment.

Many states and local agencies require spark arrestor mufflers on chain saws and other types of engines. In many areas it is illegal to tamper with or remove a spark arrestor device. Please check state or local authorities to determine if spark arrestor regulations are in effect in your area.

Pete Romot
Technical Service Advisor

PR/gf

DATE 1-3-80



TECHNICAL SERVICE BULLETIN

NO. 180-003

AFFECTS: ST-100 ABOVE LOT NUMBER x0004xxxx

SUBJECT: FELT FUEL FILTER KIT #A-95493

In order to minimize leakage past the fuel inlet needle in the carburetor, a felt filter is now being used in place of the bronze filter. It has been found that small bits of dirt (less than .004 in diameter) are gathering on the inlet needle tip and holding it open. The felt filter will minimize the number and the size of the pieces that enter the carburetor. This change has been incorporated into all units built above lot number 0004.

To service units built prior to lot number 0004 that may have the above mentioned problem, use kit #A-95493. This kit includes:

30818 Plug, expansion
65144 Gasket
93887 Fitting, Fuel Inlet
94544 Screen, Inlet
95484 Filter, Fuel
17429 Sheet, instruction

CAUTION:

If an inlet needle leaks the problem cannot be solved by only replacing the bronze filter with a felt filter. The carburetor must be cleaned thoroughly, especially the inlet needle and seat, and the inlet screen must be replaced. Follow instructions supplied with the kit.

NOTE: This kit must only be used with the new carburetor housing #A-95327. The new housing can be recognized by it's "beaded" gasket surfaces.

One half hour of warranty labor time will be allowed for installing this kit on a unit.

Eddie Turner
Forestry Products
Service Manager



TECHNICAL SERVICE BULLETIN

NO. 180-004

AFFECTS: CHAIN SAWS WITH SOLID STATE IGNITION SYSTEMS

SUBJECT: CHECKING SOLID STATE IGNITION SYSTEMS

With more Solid State ignition systems being used as standard equipment on our chain saws, basic troubleshooting procedures should be reviewed:

First of all, a test spark plug is needed to check the spark of a unit. Use a good new spark plug, recommended for that particular unit, and break off the ground ("L" shaped) electrode. A good module will produce a spark that will jump from the rim of the test plug to the center electrode. The test plug simulates a spark under compression. If a spark is weak it will fail to jump the gap of the test plug.

Always ground the test plug to an unpainted metal surface on the saw when checking for spark. NOTE: DO NOT ground near the spark plug hole on the cylinder.

A good spark for a Solid State ignition should show as a thin red spark, unlike the bright blue spark produced by a breaker point ignition. In a bright light condition a Solid State spark may be hard to see.

When checking for spark, a good starting pull (over 800 RPM) is required. Also, a few pulls may be needed before a spark will show.

If you get no spark using the spark plug from the unit, but get a spark with the test plug, you may suspect the spark plug is faulty. Check the condition of the electrodes and porcelain on the spark plug. Also, make sure that the spark plug is a type recommended for that particular unit and the electrodes are gapped properly.

If you do not get a spark with the test plug, check the following items before deciding if the module may be faulty.

General Problems:

1. Check the stop switch lead, spark plug lead, and spark plug cap for nicks, cuts, or faulty connections.
2. Check for a defective or loose stop switch. If no spark is observed with the test plug, disconnect the switch wire and test again. If spark appears, the switch is defective and should be replaced.

cont'd on back

DATE 3-5-80

3. Check the air gap between the rotor magnets and the module core as recommended in the owners manual (usually .010-.012 inch).

If no problems can be detected from the mentioned checks, make sure that the module is properly grounded and check for spark again. If there is no spark, replace the module, reset the air gap and re-check for spark.

If a unit has symptoms of repeated module failure, the problem may be with the rotor. Install a rotor that is known to give good operation, re-set the air gap, and re-check for spark.

Pete Romot
Technical Service Advisor

ds

Leon's Chainsaw Parts & Repair
Do Not Sell or Reproduce



TECHNICAL SERVICE BULLETIN

NO. 180-005**AFFECTS:** ST 100**SUBJECT:** Fuel Shut Off 95810

The fuel tank on the ST100 being in the handle allows us to eliminate the fuel pump part of the carburetor. The fuel in the handle flows "down hill" via gravity to the carburetor.

A "fuel pump" equipped carburetor or a fuel storage system using a fuel pump does not employ a fuel shut off device since no fuel flows when the pump is stopped. In a gravity fed system fuel continues to flow and in the case of the ST100 we depend on atmospheric pressure and a spring controlled needle valve to shut off the fuel flow when the engine stops. In the majority of situations this inlet needle valve is sufficient, but is subject to being upset (opened) through a jarring blow, being dropped, excessive pressure, dirt in fuel that may have by-passed a filter, etc..

In order to decrease the possibility of fuel by-passing the carburetor inlet needle and flooding the carburetor, we have added a simple fuel line shut off clamp, Part No. 95810.

We suggest that you include clamp 95810 with all model ST100's in your possession, new units below S/N 100650001 and used units in your location for repair.

Please contact your nearest Service Center and request the quantity you require. Initially as many clamps as you need will be furnished at no charge. This clamp can be installed by almost anyone in one minute or so.

R. S. Townsend
Director Product Service

rm
Attachment

DATE March 13, 1980



TECHNICAL SERVICE BULLETIN

NO. 180-006

AFFECTS: 150-A0, XL, XL-2, SUPER-2, VI-SUPER-2, ST-100, ST-200

SUBJECT: NEEDLE BEARING 12530 & 68513

We presently have two vendors who are supplying two different types of crankshaft needle bearings under part numbers 12530 and 68513.

One vendor is supplying a caged needle bearing (the needles are mechanically retained and cannot fall out).

The other is supplying a needle bearing in which the needles are held in only by a layer of grease. This bearing contains twenty loose needles.

Care should be taken when disassembling the needle bearings because of the possibility of knocking the needles loose, if they are the grease retained type. This would give the appearance of bearing failure.

A handwritten signature in cursive script that reads "Pete Romot".

Pete Romot
Technical Service Advisor

ds

DATE 3-24-80



TECHNICAL SERVICE BULLETIN

NO. 180-007

AFFECTS: ST-200 STRING TRIMMER

SUBJECT: 94455 ALIGNMENT TOOL; 94482 SHAFT HOLDER TOOL

In order to properly service the ST-200, two service tools will be required.

- I. 94455 Engine alignment tool is used to center the engine and clutch drum to the left engine housing. This tool is necessary to ensure proper operation of the flexible drive shaft.

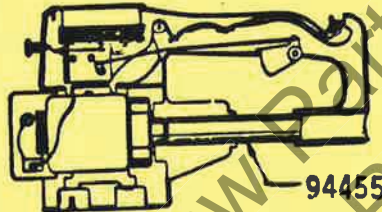

- II. 94482 Shaft tool is used to lock the drive shaft to the lower bearing housing for removal and assembly of the drive connector for string head.



These parts are available and can be ordered from your R.D.C. or Service Center.

bh

Pete Romot
Technical Service Advisor

DATE 3-27-80



TECHNICAL SERVICE BULLETIN

NO. 180-008

AFFECTS: ST-100, LOT #0060xxxx AND ABOVE

SUBJECT: (1) NEW MUFFLER BRACKET A-95238-B (2) SLIDE & SPRING KIT A-95689

A new muffler bracket kit A-95238-B will replace the old muffler bracket A-95053, which is being made "no longer supplied".

Included in this kit will be a redesigned muffler bracket, made from 1/4 inch diameter rod, (see picture below), and two #8-32 screws and nuts for fastening the bracket to the muffler.

Also included is a new bolt 82387 (1 3/4 inch) that will replace the old bolt (1 5/8 inch). This bolt holds the muffler bracket to the fuel tank tube and starter housing.

NOTE: The longer bolt must be used in order to maintain the electric ground continuity between the new muffler bracket and the fuel tank tube. This is necessary for the stop switch to operate properly.

Old Part "Superseded By"

A-95053 Muffler
Bracket

82374 Rib Neck Bolt
(1 5/8 inch)

New Part

A-95238-B Muffler
Bracket Kit

Includes:

82387 Rib Neck Bolt
(1 3/4 inch)
81223 Lock-Nut #8-32
82253 Panhead Screw
#8-32 x 3/8



OLD BRACKET



NEW BRACKET

The slides and springs for the string advance system are no longer available separately. They are now packaged as a kit, part number A-95689. All previous part numbers for the individual slides and springs have been superseded to A-95689.

KIT - SLIDE & SPRING A-95689

Includes:

Spring - Hi Speed
Slide - Hi Speed
Slide - Lo Speed
Spring - Lo Speed

Adjust your parts list accordingly.

Pete Romot
Pete Romot
Technical Service Advisor

ds

Leon's Chainsaw Parts & Repair
Do Not Sell or Reproduce



TECHNICAL SERVICE BULLETIN

NO. 180-009

AFFECTS: 550-A0 AND C-72

SUBJECT: BOW GUIDES BG-14001-A2, BG-14003-B2, AND BG-14001-B2

At present there are two bow guides available for the 550-A0.

<u>Part Number</u>	<u>Gauge</u>	<u>Chain</u>
BG-14001-A2	.050	38-C50-81
BG-14003-B2	.063	40-C63-74

We have had reports that the 38-C50-81 chain is too short and will not fit the BG-14001-A2 bow guide. We have determined that the problem lies in the bow and not the chain.

If you have this problem, simply file out the guide bar slot 1/4". See illustration below. The metal in this area is soft and will file easily. **DO NOT** add a drive link to the chain. The vendor has been made aware of this problem and will correct it.



NOTE: It is usually necessary to add an extra inner guide bar shim (70399) when installing a bow guide on a 550. This will assure proper alignment between the bow guide and the sprocket.

To avoid chain interference, replace the existing C-72 handlebar with a new one, designed for bow guides. Order handlebar (A-64727) and mounting screw (80886).

For additional clearance, shim out the bow guide with one or two guide bar plates (58671-B).

over

DATE 4-7-80

WARNING: Do not attempt to install a bow guide to the C-72 without making these changes.



Eddie Turner
Service Manager
Forestry Products

Leon's Chainsaw Parts & Repair
Do Not Sell or Reproduce



TECHNICAL SERVICE BULLETIN

NO. 180-010

AFFECTS: SXL-A0, XL-12

SUBJECT: A-69633-A SPROCKET & DRUM

Sprocket and drum A-69633-A, which includes roller bearing 64124 and inner race 65746-B, has been superseded by sprocket and drum A-65884.

The bearing and race are not supplied as part of sprocket and drum A-65884 and must be ordered as individual service parts.

<u>Old Number</u>	<u>" Superseded By "</u>	<u>New Number</u>
A-69633-A Sprocket & Drum		A-65884 Sprocket & Drum
		64124 Roller Bearing
		65746-B Inner Race

Adjust your parts lists accordingly.

Pete Romot
Technical Service Advisor

ds

DATE 4-11-80



TECHNICAL SERVICE BULLETIN

NO. 180-011**AFFECTS:** CHAIN SAWS**SUBJECT:** "NEW" TILLOTSON CARBURETOR REPAIR KITS

In order to simplify their parts system and to better serve their customers, Tillotson has revamped their repair kits by taking out some parts that were rarely used and only supplying the essential parts used for a "standard" repair. These "new" kits will replace their old kits and their gasket/diaphragm sets. Below you will find a list of gasket/diaphragm sets and repair kits that have been superseded by the "new" repair kits.

<u>Gasket/Diaphragm Set</u>	<u>"Superseded By"</u>	<u>New Repair Kit</u>
70094	"	95697
63711	"	95698
63590	will be made no longer supplied when exhausted	

<u>Old Repair Kit</u>	<u>"Superseded By"</u>	<u>New Repair Kit</u>
68663 (when exhausted)	"	95695
94944	"	95696
70098, 70764, 93025, 94810, 95243	"	95697
50590, 67869, 67870, 69790	"	95698
68659, 68661, 68662	"	95700

Generally, these kits will contain the following:

- Welch Plugs (where necessary)
- Main Diaphragm
- Main Diaphragm Gasket
- Fuel Pump Diaphragm
- Fuel Pump Gasket
- Inlet Screen
- Module Metering (Circuit) Gasket
- Inlet Needle
- Inlet Control Lever

over

DATE 4-17-80

Most kits are designed to service a wide variety of carburetors from one series. For example: One kit will service all HK series carburetors because it contains 3 module metering gaskets. Be sure to refer to any instructions contained in these kits.

It should be noted that these kits will decrease in price because of their simplicity.

Remember, individual parts, gasket/diaphragm sets and check valve kits are no longer available. Only these new lower cost repair kits will be in service parts. Please keep in mind that this applies to Tillotson only at this time.



Eddie Turner
Service Manager
Forestry Products

ds

Leon's Chainsaw Parts & Repair
Do Not Sell or Reproduce



TECHNICAL SERVICE BULLETIN

NO. 180-012

AFFECTS: CHAIN SAWS, STRING TRIMMERS, MULTI-PURPOSE SAWS,
TWO-CYCLE PUMPS
SUBJECT: CARBURETOR REPAIR PARTS

In an effort to simplify the task of ordering replacement parts for Homelite carburetors, a reference chart has been provided for you on the back of this page.

This chart will list the unit model, the Homelite part number of the carburetor, the vendor part number of the carburetor, and any kits or parts that are available to service the carburetor.

NOTE: This chart covers only those units that are presently being produced and the carburetors that are on them. If it is necessary to service a model that is not listed, refer to Dealer Service Memo #705.

Eddie Turner
Service Manager
Forestry Products

ds

DATE 5-1-80

UNIT	HOMELITE NUMBER	VENDOR NUMBER	REPAIR KIT NUMBER	GASKET DIAPHRAGM NUMBER	CHECK VALVE KIT	INLET NEEDLE	HI ALTITUDE KIT	GOVERNOR
XL, XL-2	A-94053 A-70551-A	HDC48-A HK-27-A	94702 95697	70655 NA	93910	64229 NA	94057 70589	
Super-2	A-94649 A-70927-B	HDC-57 HK-16-C	94056 95697	70655 NA	93910	64229 NA	94057	
VI-Super-2	A-94650	HDC-58	94061	70655	93910	64229	94057	
150-A0	A-69957-B A-70155-A	HDC-54 HK-3B	93200-B 95697	94701 NA	65386	64229 NA		
SEZ-A0	A-68415-A	HDC-44	93203-A	70655	65386	64229		
XL-12, SXL-A0	A-68407-A A-69647-A	SDC-62 HS-179-B Zama	67020 95698 94954	70811 NA 94952	65386	64229 NA		
360	A-93866	HDC-39	93205-A	93754	65386	64229		
550	A-93964-B	SDC-69-A	94275	70811	93910	64229		
SXL-925	A-69812-A	HS151-B	95698	NA	69793	NA	A-69819	70334
C-72	A-59427-A	HL-141-D	95700	NA		NA		
750	A-94108	WB-9	94131	95241	95240	64229		
S-1050, S-1130-6	A-70602-A	SDC-74	94877	94876	65386	64229		93615
S-HIZ-66	A-58102	HL-117-C	95700	NA		NA		
ST-100	A-93938 A-93888	MA-43 HU42A	94549-A 95696	NA	94548	64229		
ST-200	A-94444	HDC-59	95341	70655	93910	64229		
XLBC-4	A-50670	HS-109-A	95698	NA		NA		
XL-98-A	A-42208-A	HS-135-A	95698	NA	A-51348	NA		A-42209
DM-50	A-46938	SDC-71	12925	70811	70035	64229		
DM-20	A-94138-1	HS202-A	95698	NA	69793	NA		
XLS-1½	A-59535-B	HS-5C	95698	NA		NA		
XLS-2	A-42205	HS-154-A	95698	NA		NA		

*NA - NOT AVAILABLE SEPARATELY

Leon's Chainsaw Parts & Reproduction Do Not Sell Or Reproduce



TECHNICAL SERVICE BULLETIN

NO. 180-013

AFFECTS: ST-100

SUBJECT: A-95327 CARBURETOR HOUSING

Some A-95327 carburetor housings have been found that have a thin wall of plastic material in the fuel transfer passage (See picture below for location).

This blockage will cause a unit to starve for fuel. These parts have been found in service parts stock in the field. Service parts stock at the B.D.C. has been checked and all incorrect parts have been removed.

Please check your stock. If any housings are found with this wall, it can be broken out with a sharp object.

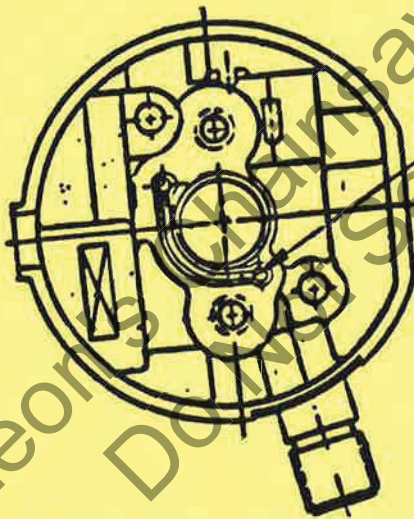

Blockage
Here

Pete Romot
Technical Service Advisor

ds

DATE 5/13/80



TECHNICAL SERVICE BULLETIN

NO. 180-014

AFFECTS: SAW CHAIN

SUBJECT: REPLACEMENT PARTS FOR HOMELITE 404 PITCH SAW CHAIN

The following parts in the G-series, for 404 pitch chain with tie straps shaped like the one pictured below in the "G" series column, will be superseded by the "K" series which will repair both G & K series chain with the exception of the cutters.

<u>DESCRIPTION</u>	<u>OLD NUMBER</u>	<u>" SUPERSEDED BY"</u>	<u>NEW NUMBER</u>
	<u>404 PITCH</u>		<u>404 PITCH</u>
	(G-SERIES)		(K-SERIES)
Drive Link	40AL64-3G		40C63-3K
Tie Strap	40AL63-4G		40C63-4K
Rivet	40AL63-5G		40C63-5K
Preset Tie Strap	40AL63-6G		40C63-6K
Repair Kit	40AL63-7G		40C63-7K
Joining Kit	40AL63-8G		40C63-8K

G-SERIES

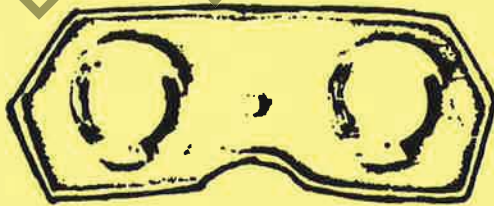

K-SERIES

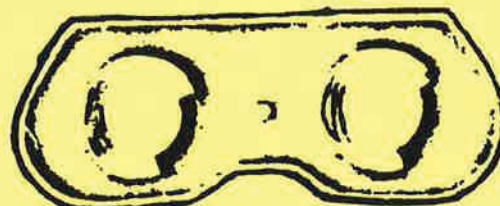

Pete Romot

Pete Romot
Technical Service Advisor



TECHNICAL SERVICE BULLETIN

NO. 180-015

AFFECTS: ST-100 AND ST-200

SUBJECT: 1. BLOWER PARTS LIST ST-100
2. LOWER HEAD ASSEMBLY ST-200

1. Instruction sheet #17400, included with the ST-100 blower, shows the blower housing as being available separately. This is a misprint. Refer to the parts list below when ordering parts.

COMPLETE ASSEMBLY #A-93597

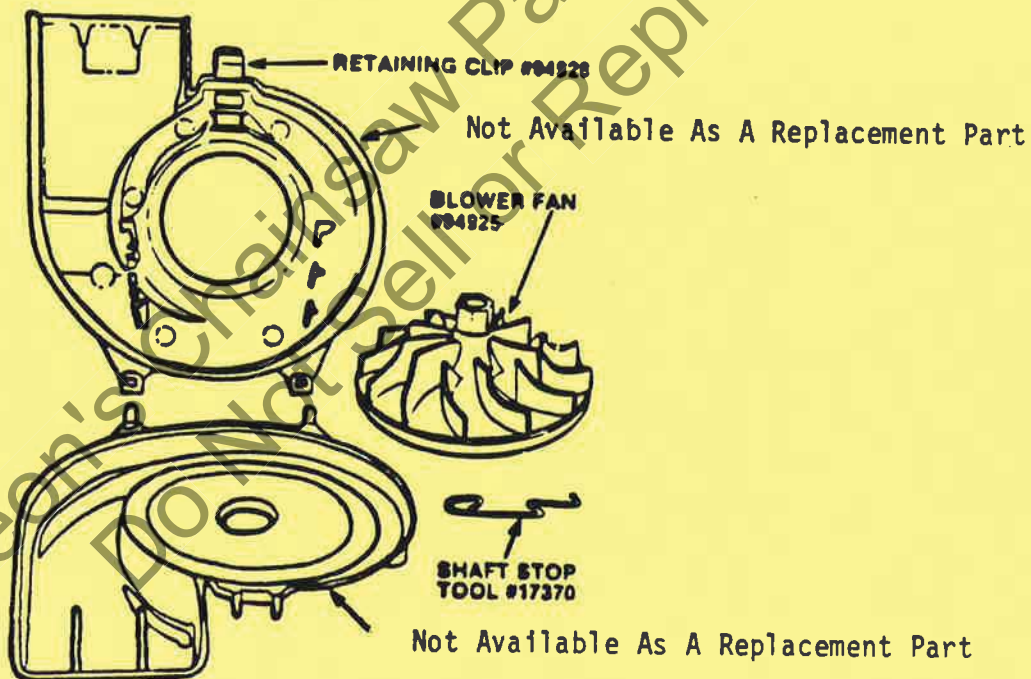

2. The ST-200 lower head housing and related parts as shown in figure 4 of the ST-200 parts list #17435 is now available as an assembly. The part number is A-95800. Refer to the parts list on the back of this page when ordering parts.

DATE 6/28/80

COMPLETE ASSEMBLY #A-95800

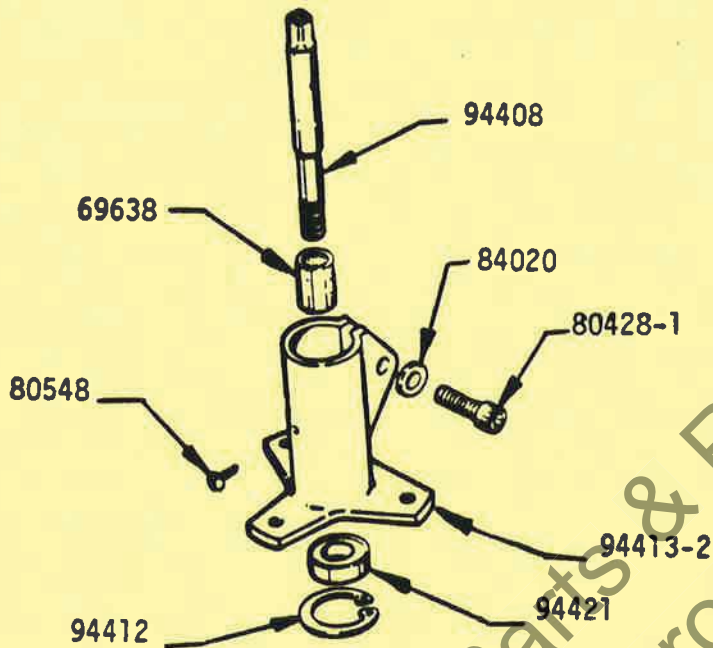

Please adjust your parts list accordingly.

REMINDER: The right engine housing must be removed before the carburetor can be removed on the ST-200.

Pete Romot
Technical Service Advisor

ds



TECHNICAL SERVICE BULLETIN

NO. 180-016

AFFECTS: XL-12, SXL-A0, DM-20, XLS PUMPS

SUBJECT: NEW RECOIL SPRING A-94842

Recoil spring #58764-A has been superseded by a new spring #A-94842. This new spring comes prepacked in a metal container. It will be used in place of the old spring and outer shield #59639-A.

When servicing units, built prior to this change, with the new spring simply install the new spring and container and discard the outer shield. The inner shield #59638-A is still required for both units built prior to and after this change. Outer shield #59639-A is still available from service parts.

SERVICE REMINDER: Any recoil spring is under extreme tension so to prevent injury due to unexpected unraveling use added caution when removing or installing the spring.

Adjust your parts lists accordingly.

Eddie Turner
Service Manager
Forestry Products

ds

DATE 7/8/80



TECHNICAL SERVICE BULLETIN

NO. 180-017

AFFECTS: ST-200

SUBJECT: BUSHING KIT A-96064

A bushing kit is being released for the driveshaft tube of the ST-200. This kit will consist of a bushing, a 1/4-28 socket head screw, a flat washer, and an instruction sheet (attached).

The bushing is inserted into the lower end of the drive tube and will prevent the tube from compressing in the clamp area causing the string/brush head to loosen and move.

All tubes in your stock (units and service parts) should be fitted with this kit. Order your kits from your Regional Distribution Center. We will allow 15 minutes for warranty labor, plus parts for each conversion.

Please adjust your parts lists to note the following changes:

	<u>NEW NUMBER</u>	<u>"SUPERSEDES"</u>	<u>OLD NUMBER</u>
Bushing Kit	A-96064		
Shaft Housing Kit	A-96063	Driveshaft Tube	A-94405
Stringtrimmer Lower Head Assembly	A-95800-A		A-95800
Brushcutter Kit	A-94479-A		A-94479
Screw 1/4-28	82416	Drive Screw #6	80548
Flat Washer	84020		

Pete Romot
Technical Service Advisor

ds
attachment

DATE 7/11/80

ST-200/ST-210 BUSHING KIT #A-96064

This bushing kit is to be installed in the lower end of the drive tube assembly. Read these instructions carefully before proceeding.

Check the lower end of the drive tube to determine whether or not a Bushing Kit has been installed. If the Bushing Kit (#A-96064) has been installed the bushing will extend to the bottom edge of the tube. You will not have to do anything else to the tube. If there is a space between the bottom edge of the tube and the inside bushing, measure from the bottom edge of the tube to the bushing. There must be a minimum of 1 1/4" (38mm). If the measurement is less than 1 1/4" (38mm) it is necessary to replace the complete drive tube assembly. Contact your local Homelite Service Center or nearest servicing dealer if you need assistance.

INSTALLATION INSTRUCTIONS FOR BUSHING KIT (#A-96064)
AND
BRUSHCUTTER (#A-94479-A) AND STRING TRIMMER (#A-95800-A)
ATTACHMENTS

1. If you have one or the other of the above attachments on your unit, remove the attachment. Discard the small #6 alignment screw that is in the front of the housing.
2. Clean all grease from the lower end of the drive shaft tube.
3. Drill a 9/32 hole (7mm) through the existing hole on the side of the drive tube (where the #6 screw was removed).
4. Line up the threaded hole in the bushing with the hole in the drive tube. (See illustration.)

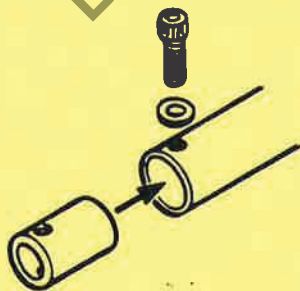

5. Install the bushing in the drive tube. The beveled edge of the bushing goes in first. If the bushing will not slide in the drive tube, tap it in with a plastic mallet. The bushing should not protrude from the drive tube.
6. If the head assembly does not have a large hole in the front of the housing, drill the existing hole out with a 9/32 drill bit (7mm).

7. Make sure the metal chips are cleaned out of the assembly before reinstalling the drive tube.
8. Install the tube into the lower head assembly until it bottoms. Align the hole in the head assembly with the hole in the drive tube.

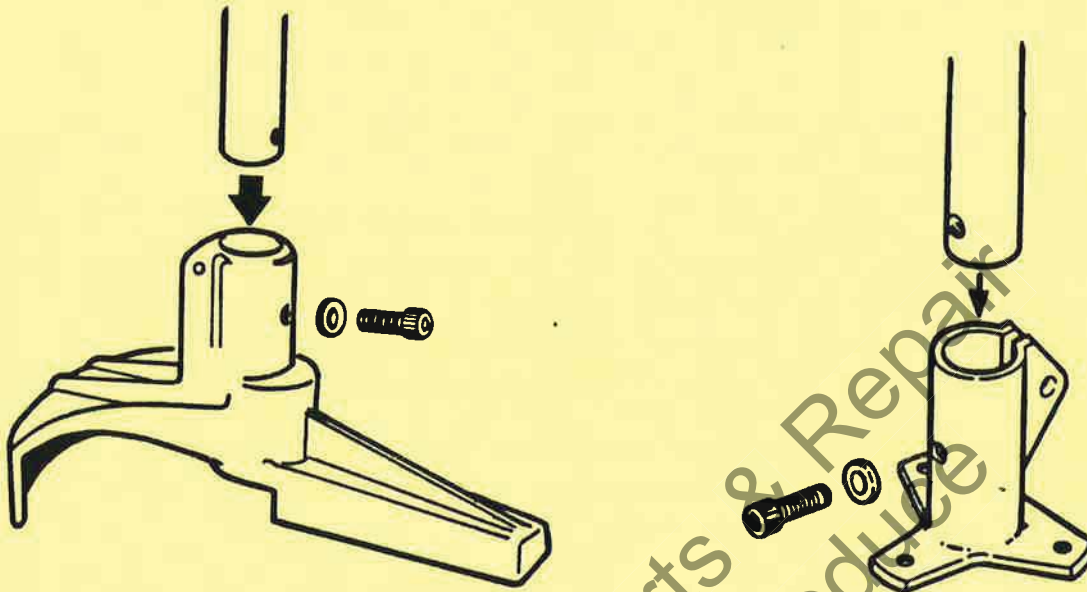

9. Install the flat washer onto the socket head screw. Install the screw into the tube. Torque the screw to 80-100 inch-pounds (9.04-11.3 Nm).
10. Tighten the clamp screw on the back of the housing. Torque the screw to 80-100 inch-pounds (9.04-11.3 Nm).

NOTE

THE FLAT WASHER MUST BE INSTALLED. IF NOT INSTALLED THE SCREW WILL INTERFERE WITH THE FLEXIBLE SHAFT.

INSTALLATION INSTRUCTIONS
FOR
NEW DRIVE TUBE ASSEMBLY (#A-96063)

The new drive tube assembly is supplied with Bushing Kit #A-96064 already installed in the lower end. The screw and washer are also supplied.

1. Install the new drive tube in the engine head as directed in your Owners Manual.
2. Follow instructions 6-10 as given above.

HOMELITE TEXTRON

Homelite Division of Textron Inc.



TECHNICAL SERVICE BULLETIN

NO. 180-018**AFFECTS:** SXL-925**SUBJECT:** CLUTCH SPIDER 65723-2A

Many dealers are still replacing clutch spiders, shoes and springs on the SXL-925. We have found that for a few dollars more these units could be converted to our new "lined" clutch, which is superior to the old six shoe clutch. The price difference is currently \$1.85.

OLD SIX SHOE CLUTCH

<u>Quantity</u>	<u>Part #</u>	<u>Description</u>
1	65723-2A	Spider
2	67441	Springs
6	69754-1B	Shoes

New three shoed "lined" clutch conversion kit part #A-94156 includes the following:

<u>Quantity Required</u>	<u>Part #</u>	<u>Description</u>
1	63462	Thrust Washer
1	93650	Thrust Washer
1	64129-A	Inner Race
1	64124	Needle Bearing
1	A-94117	Hub & Drum
1	93811	Spider
3	A-94126	Clutch Shoe
3	93814-A	Clutch Spring
1	93628	Clutch Cover
3	93126	Torx Screws
3	82253	Screws

Pan head screws 82253 can be used as an alternative to 93126 for the clutch cover. Clutch cover screws should be secured with Loc-Tite.

Please keep this in mind when servicing units that have the six shoe clutch.

Adjust your parts lists accordingly.

Eddie Turner
Service Manager
Forestry Products



TECHNICAL SERVICE BULLETIN

NO. 180-019

AFFECTS: SEZ-A0

SUBJECT: Automatic Oil Pumps

At present there is one oil pump to service units built with the old single line oiling system and units built with the new double line oiling system. The part number of this pump is A65212-B. Modifications must be made in the field to the pump to service either system.

It has come to our attention that the majority of these pumps are used to service the new double line system. In order to avoid modification to A65212-B we are making the current pump, now used in production, available to Service Parts. The part number is A69799.

Service single line oiling systems with A65212-B.

Service double line oiling systems with A69799.

Please note that A65212-B will still service both systems however, we encourage you to use this pump on the single line system only. The reason for this is that when our present supply of A65212-B pumps is exhausted they will no longer be available.

Adjust your parts lists accordingly.

Eddie Turner
Service Manager
Forestry Products

bh

DATE 8/4/80



TECHNICAL SERVICE BULLETIN

NO. 180-020

AFFECTS: SEZ-A0, XL-12, SXL-A0, XLBC BRUSHCUTTERS, XLS PUMPS

SUBJECT: AIR FILTER MOUNTING BRACKETS AND NUTS

When ordering air filter mounting brackets and nuts for the above mentioned units, refer to the list below. This should clear up any confusion encountered in the past when ordering these parts.

XL-12, XLBC Brushcutters, XLS Pumps with single reed valve use:

A-65272 Mounting Nut (1/4-28)
A-58818-B Mounting Bracket

XL-12, SXL-A0 with pyramid (4) reed valves use:

A-65272 Mounting Nut (1/4-28)
A-59822-B Mounting Bracket

When replacing a mounting bracket on any SEZ-A0 use kit #A-95346. This kit includes a mounting bracket, a mounting nut #A-65272 (1/4-28), and two (2) thread forming screws #82327 to secure the bracket to the throttle handle.

SEZ-A0's built between serial number X9002XXXX and serial number X0175XXXX use a 1/4-20 mounting nut part #A-65272-2 instead of a 1/4-28 mounting nut.

Adjust your parts lists accordingly.

Eddie Turner
Service Manager
Forestry Products

ds

DATE 8/26/80



TECHNICAL SERVICE BULLETIN

NO. 180-021

AFFECTS: ALL MODELS

SUBJECT: WARRANTY OF STARTER ROPES

"Is a starter rope covered under warranty?" This question has been asked by many of our dealers. Our warranty says "In addition, this warranty does not cover tune ups or replacement of non-defective parts (such as spark plugs, filters, starter ropes, etc.) that may wear out with reasonable use within the warranty period or which may require replacement in connection with normal maintenance".

However, the above statement refers to "non-defective" parts. A starter rope could be considered warranted if the rope itself was defective or frayed or broken because another part failed and the customer could not start the unit. For example: After a few months use your customer broke the starter rope on his XL-2 trying desperately to crank it. After replacing the rope you, the dealer or technician, find that the solid state module has failed and that is why the unit would not start. The customer should not be held responsible for the repair of the starter rope. This should be covered under warranty.

In the example above the rope was "non-defective" but, it broke as a result of a "defective" part.

It is basically up to you as a Homelite dealer to make a fair judgement in a situation like this.

Thank you for your cooperation.

Eddie Turner
Service Manager
Forestry Products

ds

DATE 9/5/80



TECHNICAL SERVICE BULLETIN

NO. 180-022

AFFECTS: SEZ-A0, XL-12, SXL-A0, ST-400

SUBJECT: SOLID STATE MODULES PART NUMBER A-94111 and 94605

This bulletin is to notify you of a change in our warranty policy regarding modules A-94111 and 94605. As of this bulletin we are asking that these modules be returned when they are replaced under warranty. Return both the claim and the module to your local Service Center.

Any warranty claim received without the module will be returned to you.

Your claim must have the "date sold" and "date failed" on it.

Thank you for your cooperation.

Eddie Turner
Service Manager
Forestry Products

ds

DATE 9/30/80



TECHNICAL SERVICE BULLETIN

NO. 180-723

AFFECTS: SEZ-A0

SUBJECT: NEW STARTER ASSEMBLY

A new starter assembly is being introduced for the SEZ-A0. This new assembly uses a "fiberglass reinforced nylon" starter housing. All new units will have this system. Refer to the parts list below when ordering parts.

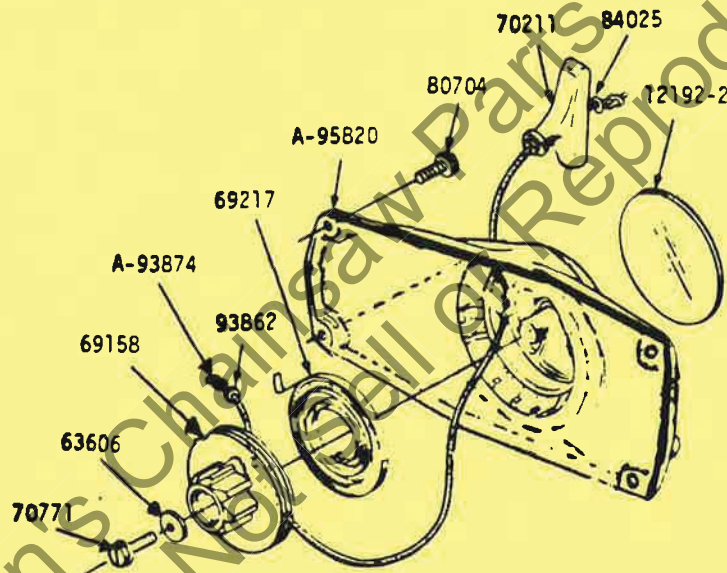

This system requires new starter pawls for the rotor. That new part number is 94336. The same rotor, springs, and studs will be used on both the new and old systems. Only the pawls have changed.

All parts for the old magnesium starter assemblies are still available from Service Parts. However, when the magnesium starter housings (part #A-65222-1) are used up a kit (part #A-95930) will be provided so that an easy change over to the plastic starter assembly can be made.

cont'd

DATE 9-15-80

This kit includes the following:

STARTER CONVERSION KIT

A-95930

Qty.

INCLUDES: Housing & Starter complete
94336 Starter Pawls
17496 Instruction Sheet

1
2
1

Please adjust your parts list accordingly.

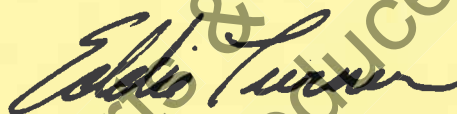

Eddie Turner
Service Manager
Forestry Products

ds

Leon's Chainsaw Parts & Repair
Do Not Sell or Reproduce



TECHNICAL SERVICE BULLETIN

NO. 180-024

AFFECTS: XL-10" AND XL-12"

SUBJECT: CHAIN OILER OILS TOO MUCH

We have found some XL's that build too much pressure in the oil tank. This pressure forces excessive oil to the guide bar.

If a customer complains of too much oil being used during cutting, check the duck bill valve (69451); it may be against the pressure line. Pull the valve away from the line and expose at least 1/16, but not more than 1/8 of the connector (69656-1A).

This will allow the pressure in the tank to "bleed" back through the porous connector, when the unit is returned to idle or shut off, preventing too much pressure from building in the tank. See picture below.

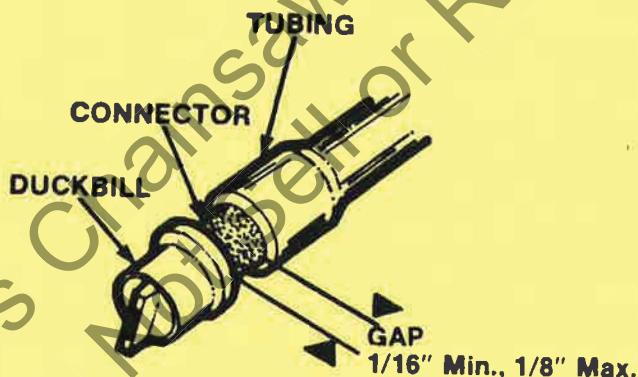

REMINDER: Do not fill the oil tank above the pressure line. Oil can seep through the porous connector and into the engine, causing "hydraulic lock" and preventing cranking. Should the engine refuse to turn over remove the spark plug to break the hydraulic lock. Then crank the engine several times to dispel the oil. Clean the spark plug thoroughly before you reinstall it.

Eddie Turner
Service Manager
Forestry Products



TECHNICAL SERVICE BULLETIN

NO. 180-025

AFFECTS: XL, XL-2, SUPER-2, VI-SUPER-2, 150 AUTO, SEZ-AO, (UP TO 16" BAR)

SUBJECT: CARRYING CASES 94215 AND 94216

We have had several requests from the field asking that handles and latches for the above mentioned carrying cases be made available through service parts.

The numbers are:

96054 Latch

96161 Handle

These handles and latches will fit both carrying case 94215 and carrying case 94216.

Eddie Turner
Service Manager
Forestry Products

ds

DATE 10/16/80



TECHNICAL SERVICE BULLETIN

NO. 180-026

AFFECTS: 750

SUBJECT: 1. THREE SHOE - LINED CLUTCH
2. HANDLE BAR

1. The 750-A0 is now being built with the new three shoe lined clutch. Refer to the parts list below when ordering parts.

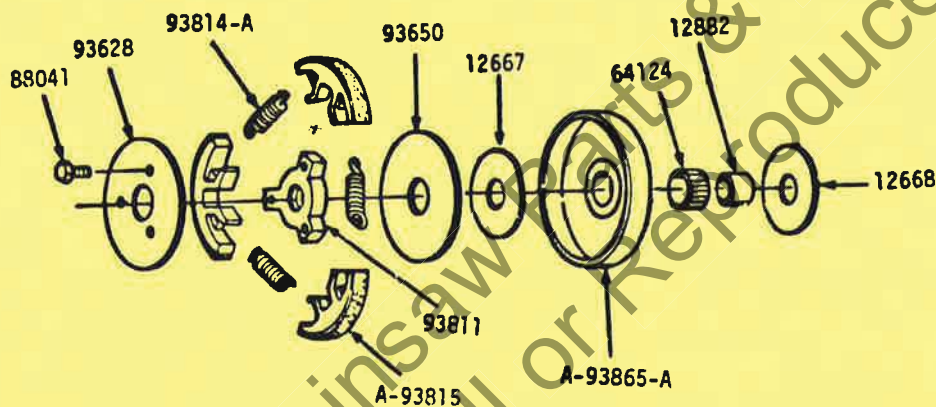

The parts shown above are also available in a conversion kit, part #A-94157.

2. The 750-A0 parts list does not show the handle bar brace and the attaching screw for the West Coast (wrap around) handle bar. Refer to the list below when servicing a wrap around handle bar.

HANDLE BAR A-12714-A

Includes:
Brace 12765-A
Screw 82262

Adjust your parts list accordingly.

Eddie Turner
Service Manager
Forestry Products



TECHNICAL SERVICE BULLETIN

NO. 180-027

AFFECTS: ST-200

SUBJECT: BRUSHCUTTER KIT A-94479-A

Some brushcutter gear heads (starting with serial number 800015657) have been produced with a blade shaft 94416 that has been assembled with two single row ball bearings and a spacer (see picture below).

We will continue to service the gear heads with the double row bearing as shown below.

NOTE: A serial number sticker has recently been added to the brushcutter gear head. Please use this number when you are filling out warranty claim forms or referring to gear head service problems.

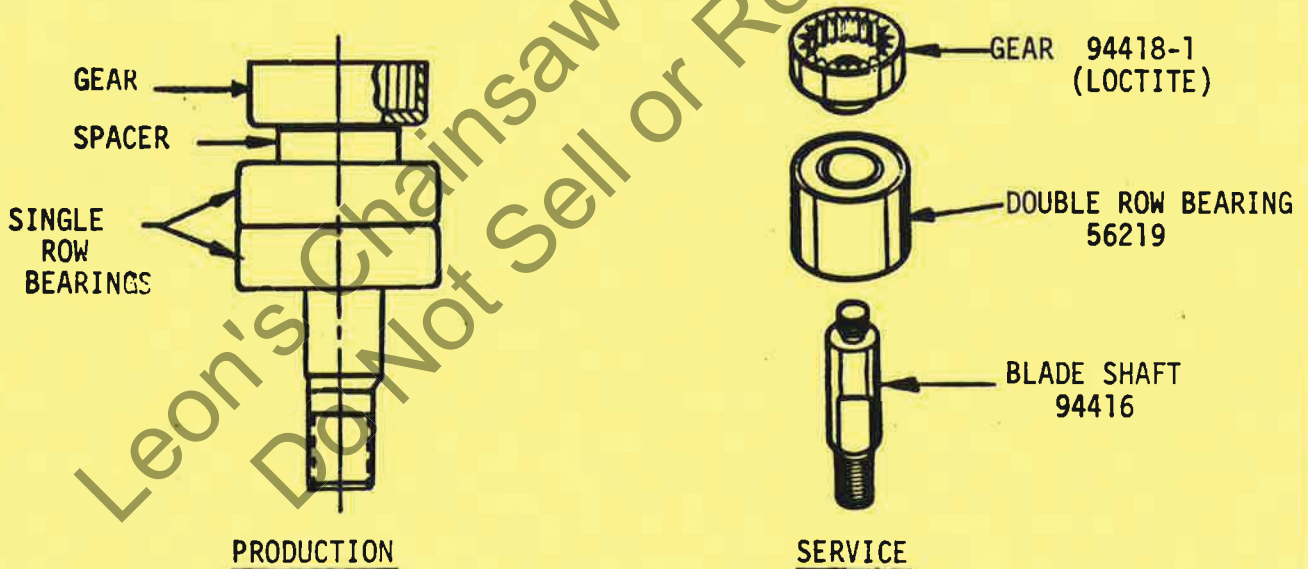

Pete Romot
Pete Romot
Technical Service Advisor

ds

DATE 11/11/80



TECHNICAL SERVICE BULLETIN

NO. 180-028

AFFECTS: XL, XL-2, SUPER-2, VI-SUPER-2, 190

SUBJECT: A-70532 CRANKSHAFT (BREAKER POINT IGNITIONS)
A-94712 CRANKSHAFT (SOLID STATE IGNITIONS)

The retaining ring and groove on the clutch end of the above mentioned crankshaft is being replaced by a threaded end and a hex nut (see picture).

Units produced with a serial number of X0290XXXX and above will have this change.

Service will continue to supply the crankshaft with grooved clutch ends until the supply is exhausted. Then crankshafts with threaded clutch ends will be supplied.

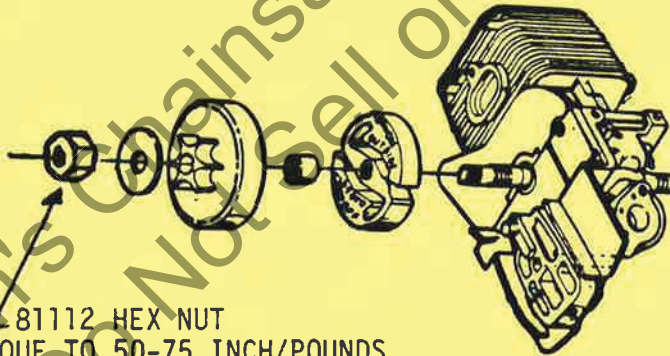

Adjust your parts lists accordingly.

Pete Romot
Pete Romot
Technical Service Advisor

ds

DATE 12/1/80



TECHNICAL SERVICE BULLETIN

NO. 180-029

AFFECTS: XL FAMILY, ST-100 & ST-200, SEZ-A0

SUBJECT: STARTER PULLEY

We are currently building the above mentioned models using two types of starter pulleys. These pulleys are different not only in design but, in color also. One is black and the other is white. These parts are totally interchangeable.

Black Pulley Part Number 94562

White Pulley Part Number 69158

Adjust your parts lists accordingly.

Eddie Turner
Service Manager
Forestry Products

ds

DATE 12/3/80



TECHNICAL SERVICE BULLETIN

NO. 180-030

AFFECTS: A. ST-200 B. RIVET SPINNER A-17163 (BENCH MODEL)

SUBJECT: SERVICE TOOLS

A. The following tools are now available for servicing the bearings for the ST-200 string trimmer lower head and the brushcutter gear head.

17498 - Needle bearing (69638) installation and removal, (for the string trimmer lower head).

17499 - Roller bearing (59462) installation, (for the brushcutter gear head).

17501 - Blade shaft, ball bearing (56219) and gear assembly installation, (for the brushcutter gear head).

B. The anvil drive bushing for the spinner crank is now available. The part number is 17494. (See picture below).

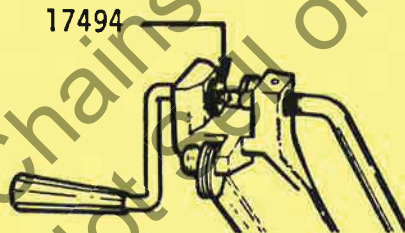

Please note these numbers in your parts list and order as required.

Pete Romot
Technical Service Advisor

ds

DATE 12/11/80



TECHNICAL SERVICE BULLETIN

NO. 180-031

AFFECTS: XL, XL-2, SUPER-2, AND VI-SUPER-2 (LOT #X0318XXXX AND ABOVE)

SUBJECT: 1. IGNITION MODULES 94711
2. SCREW #82383

SUBJECT #1

In order to have two sources of supply for solid state ignition modules 94711 we have added another vendor. This new vendor will be supplying modules for the above mentioned units as well as string trimmers. These new modules will be orange colored. They are totally interchangeable with the black Phelon modules.

SUBJECT #2

The slotted pan head screw (82216) that secures the engine housing to the engine on the above mentioned models has been changed to a truss head screw (82393). The truss head screw has the appearance of a phillips head screw. However, do not use a phillips head screwdriver to remove them. We recommend using a #2 posidriv bit, part #24304.

Eddie Turner
Service Manager
Forestry Products

ds

DATE 12/23/80



TECHNICAL SERVICE BULLETIN

NO. 280-002**AFFECTS:** G3600-1,-2 and G4800-1,-2**SUBJECT:** 1800 RPM GENERATORS

The G series 1800 RPM generators do not have the max power feature that the contractor line generators had. The load on the generator must be split between both outlets on the 120 when trying to pull full load. Each side of the receptacle is fused and if more than 20 amps is pulled out of one side the fuse will blow. The full rated amperage can be pulled out of the 120/240 receptacle. If the rated amperage is exceeded at this receptacle the circuit breaker will trip.

If it is desirable to pull the full rated load at 120 volts it will be necessary to replace the 120/240 receptacle with a 120 volt 30 amp receptacle (part #42601) and change the wiring.

The wiring change is as follows:

1. Remove wire T3 from terminal 3 of terminal block.
2. Remove wire 11 from terminal 6 of terminal block.
3. Install wire T3 on terminal 6 of terminal block.
4. Install wire 11 on terminal 3 of terminal block.
5. Remove 230 volt receptacle from control box.
6. Remove wires from 230 volt receptacle.
7. Install wires on 120 volt receptacle as follows:
 - a. wires 1,2,5 on brass terminal
 - b. wires N1,N2 on "W" terminal
 - c. wires G1,G2 on "G" terminal

The fuses will protect the duplex receptacles and the circuit breaker will continue to protect the generator windings from overload.

Bill Borachok
Construction Equipment
Service Manager

ds

DATE 2-20-80



TECHNICAL SERVICE BULLETIN

NO. 280-004

AFFECTS: EP220-1, EP215-1, AP220-1, AP220-2, AP215-1
AP215-2, AP320-1, AP315-1

SUBJECT: CHEMICALS THAT MAY BE PUMPED BY THERMOPLASTIC PUMPS

We have received questions on what type of materials our thermoplastic pumps can handle.

Attached is a list that shows the amount of chemical that may be pumped and their temperature limits. Care must always be taken when pumping chemicals of any type.

If additional copies of this list are needed, please order from your Service Center by part number ST-3048.

Thank you for your cooperation.

Rick Mason

Rick Mason
Technical Service Advisor

ds
attachment

DATE 3-20-80

CHEMICALS THAT MAY BE PUMPED WITH HOMELITE'S THERMOPLASTIC PUMPS

THERMOPLASTIC PUMP MODEL	LIMITS OF USE	EP220-1 EP215-1		AP220-1 AP220-2 AP215-1 AP215-2		AP320-1 AP315-1
		BUNA-N	EPDM & VITON	BUNA-N	EPDM & VITON	BUNA-N
TYPE OF ELASTOMERS IN PUMP	SEE KEY					
CHEMICAL						
Acetic Acid (Vinegar)	1		X		X	
Aluminum Hydroxide	6	X	X	X	X	X
Aluminum Sulfate	2	X	X	X	X	X
Ammonia	3,4	X	X	X	X	X
Ammonium Persulfate			X		X	
Ammonium Phosphate		X	X	X	X	X
Ammonium Sulfate	5	X	X	X	X	X
Beer		X	X	X	X	X
Calcium Carbonate	6	X	X	X	X	X
Calcium Chloride	3,5	X	X	X	X	X
Carbonic Acid	6	X	X	X	X	X
Citric Acid	4		X		X	
Fatty Acids	6		X		X	
Ferric Nitrate	5		X		X	
Formaldehyde	3	X	X	X	X	X
Mineral Oils	4	X		X		X
Nickel Chloride	2,5		X		X	
Nickle Sulfate	2,5	X		X		X
Potassium Bicarbonate	3	X		X		X
Potassium Carbonate	2	X	X	X	X	X
Potassium Chlorate	1	X	X	X	X	X
Potassium Chloride	1	X	X	X	X	X
Potassium Nitrate	1	X	X	X	X	X
Potassium Sulfate	2	X	X	X	X	X
Soaps	6	X		X		X
Sodium Bicarbonate	2	X	X	X	X	X
Sodium Bisulfate	2	X	X	X	X	X
Sodium Bisulfite		X	X	X	X	X
Sodium Carbonate	2	X	X	X	X	X
Sodium Chloride	3	X	X	X	X	X
Sodium Phosphate	2	X	X	X	X	X
Sodium Silicate	2	X	X	X	X	X
Sodium Sulfate	2	X	X	X	X	X
Sodium Sulfide	2	X	X	X	X	X
Solvasol		X	X	X	X	X
Stearic Acid	4		X		X	
Stoddards Solvent	4	X	X	X	X	X
Tartaric Acid		X	X	X	X	X
Zinic Sulfate	3	X	X	X	X	X
USE LIMITS KEY:						
5% solution or mixture of pumpage	1					
10% solution or mixture	2					
20% solution or mixture	3					
70° F temperature limit	4					
80° F temperature limit	5					
120° F temperature limit	6					

Maximum pumping temperature is limited to 125° F.

Check specific gravity of solution or mixture to avoid overloading pump driver.

ST-3048



TECHNICAL SERVICE BULLETIN

NO. 280-005

AFFECTS: G3600-2, G4800-2, G7200-1, G7200-2, G118001,
AND G12000-2
SUBJECT: GENERATORS -- GENERAL INFORMATION

The above listed generators have battery ignition systems. These generators will not run without a battery because there will be no spark to the ignition.

DO NOT TRY TO START THESE UNITS WITHOUT A BATTERY.

Bill Borachok
Service Manager
Construction Equipment

ds

DATE 3-24-80

Courtesy of undee7059
Do Not Sell or Reproduce

**TECHNICAL SERVICE
BULLETIN**NO. 280-006

AFFECTS: SP-150-1, SP-150-1A, SP-150-B, SP-200-1, SP-200-2,
SP-200-2A, SP-200-2B, SP-300-1, SP-300-1A, SP-300-1B
SUBJECT: SUBMERSIBLE PUMP KITS

There has been some confusion as to what submersible pump kits should be used. I have listed below the correct kits to use.

SUBMERSIBLE PUMP KITS

	Voltage Conversion (115 to 230)	Voltage Conversion (230 to 115)	Level Control
SP-150-1	A-43238	N/A	A-46351-1
SP-150-1A	A-46413	N/A	A-46351
SP-150-1B	A-47560-A	N/A	A-46351
SP-200-1	N/A	A-43237	A-46351-1
SP-200-2	A-43339	N/A	A-46351-1
SP-200-2A	A-46415	N/A	A-46351
SP-200-2B	A-47650-A	N/A	A-46351
SP-300-1	N/A	N/A	A-46351-1
SP-300-1A	N/A	N/A	A-46351
SP-300-1B	N/A	N/A	A-46351

N/A means Not Applicable.

Bill Borachok
Service Manager
Construction Equipment

bh

DATE 3-27-80



TECHNICAL SERVICE BULLETIN

NO. 280-007**AFFECTS:** ALL CURRENT HOMELITE GENERATORS**SUBJECT:** GENERATOR PLUGS AND RECEPTACLES

<u>GENERATOR MODEL</u>	<u>RECEPTACLE TYPE</u>	<u>VOLTAGE</u>	<u>AMPERAGE</u>	<u>RECEPTACLE P/N</u>	<u>PLUG P/N</u>
G3600-1	duplex	125	20	51373	43863
	twistlock	125/250	20	46508	47600
G3600-2	duplex	125	20	51373	43863
	twistlock	125/250	20	46508	47600
G4800-1	duplex	125	20	51373	43863
	twistlock	125/250	20	46508	47600
G4800-2	duplex	125	20	51373	43863
	twistlock	125/250	20	46508	47600
G7200-1	duplex	125	20	51373	43863
	twistlock	125/250	30	46718	47601
G7200-2	duplex	125	20	51373	43863
	twistlock	120/208	30	46858	47603
G11800-1	duplex	125	20	51373	43863
	twistlock	125/250	50	46719	47602
G12000-2	duplex	125	20	51373	43863
	twistlock	120/208	50	46859	47604
GD7200-1	duplex	125	20	51373	43863
	twistlock	125/250	30	46718	47601
GD7400-2	duplex	125	20	51373	43863
	twistlock	120/208	30	46858	47603
GD12000-1	duplex	125	20	51373	43863
	twistlock	125/250	50	46719	47602
GD12300-2	duplex	125	20	51373	43863
	twistlock	120/208	50	46859	47604

cont'd

DATE 4-7-80

<u>GENERATOR MODEL</u>	<u>RECEPTACLE TYPE</u>	<u>VOLTAGE</u>	<u>AMPERAGE</u>	<u>RECEPTACLE P/N</u>	<u>PLUG P/N</u>
170A15-1A	duplex	125	20	51373	43863
172A20-1B	duplex	125	20	51373	43863
174A27-1B	duplex	125	20	51373	43863
	twistlock	125	30	42601	43326
	twistlock	125/250	20	46508	47600
176A35-1C	duplex	125	20	51373	43863
	twistlock	125	30	42601	43326
	twistlock	125/250	20	46508	47600
177D38-1	duplex	125	20	51373	43863
	twistlock	125	30	42601	43326
	twistlock	125/250	20	46508	47600
178A50-1B	duplex	125	20	51373	43863
	twistlock	125	30	42601	43326
	twistlock	125/250	20	46508	47600
180A75-1A	duplex	125	20	51373	43863
	twistlock	125	30	42601	43326
	twistlock	125/250	30	46718	47601
E1350-1	duplex	125	20	51373	43863
E1700-1	duplex	125	20	51373	43863
E2250-1	duplex	125	20	51373	43863
E3000-1A	duplex	125	20	51373	43863
	twistlock	125/250	20	46508	47600
E4000-1A	duplex	125	20	51373	43863
	twistlock	125/250	20	46508	47600

Bill Borachok

Bill Borachok
Service Manager
Construction Equipment

ds



TECHNICAL SERVICE BULLETIN

NO. 280-014

AFFECTS: G SERIES GENERATORS

SUBJECT: WIRES SHORTING ON G SERIES GENERATORS

To prevent the transformer wires from shorting on the stator, a wire tie must be installed on the transformer as shown in the picture below. The wire tie will tie the lower wires to the transformer lacing. A second wire tie should be installed on the wire to keep them bundled as illustrated.

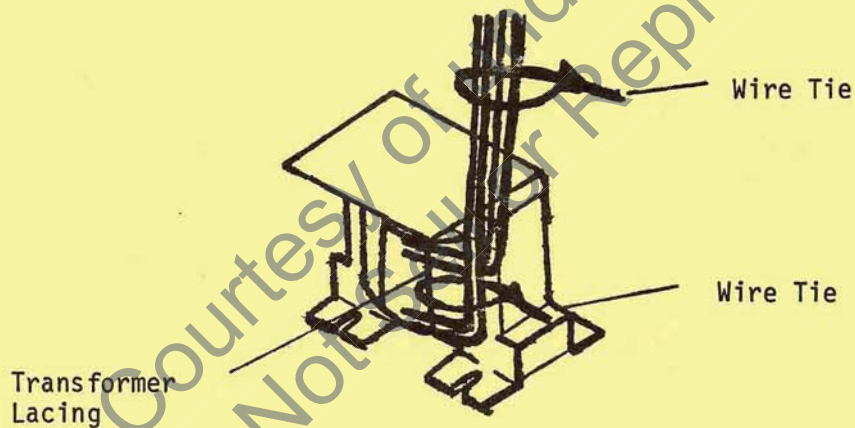

Bill Borachok
Bill Borachok
Service Manager
Construction Equipment

bh

DATE 7/15/80



TECHNICAL SERVICE BULLETIN

NO. 280-019

AFFECTS: GENERATORS

SUBJECT: ALL EXTRA HEAVY DUTY GENERATORS

The early production of G3600-1, G3600-2, G4800-1, G4800-2, and G7200-1 were built with fuses protecting the 120 volt output lines. When the 120 volt line of the generator is overloaded the fuse will blow and have to be replaced. This causes an inconvenience to the customer.

To improve this situation a kit to convert the fuse system to circuit breakers has been made available. The part number for this kit is A-47989.

A handwritten signature in cursive script that reads "Bill Borachok".

Bill Borachok
Service Manager
Construction Equipment

ds

DATE 12/22/80