

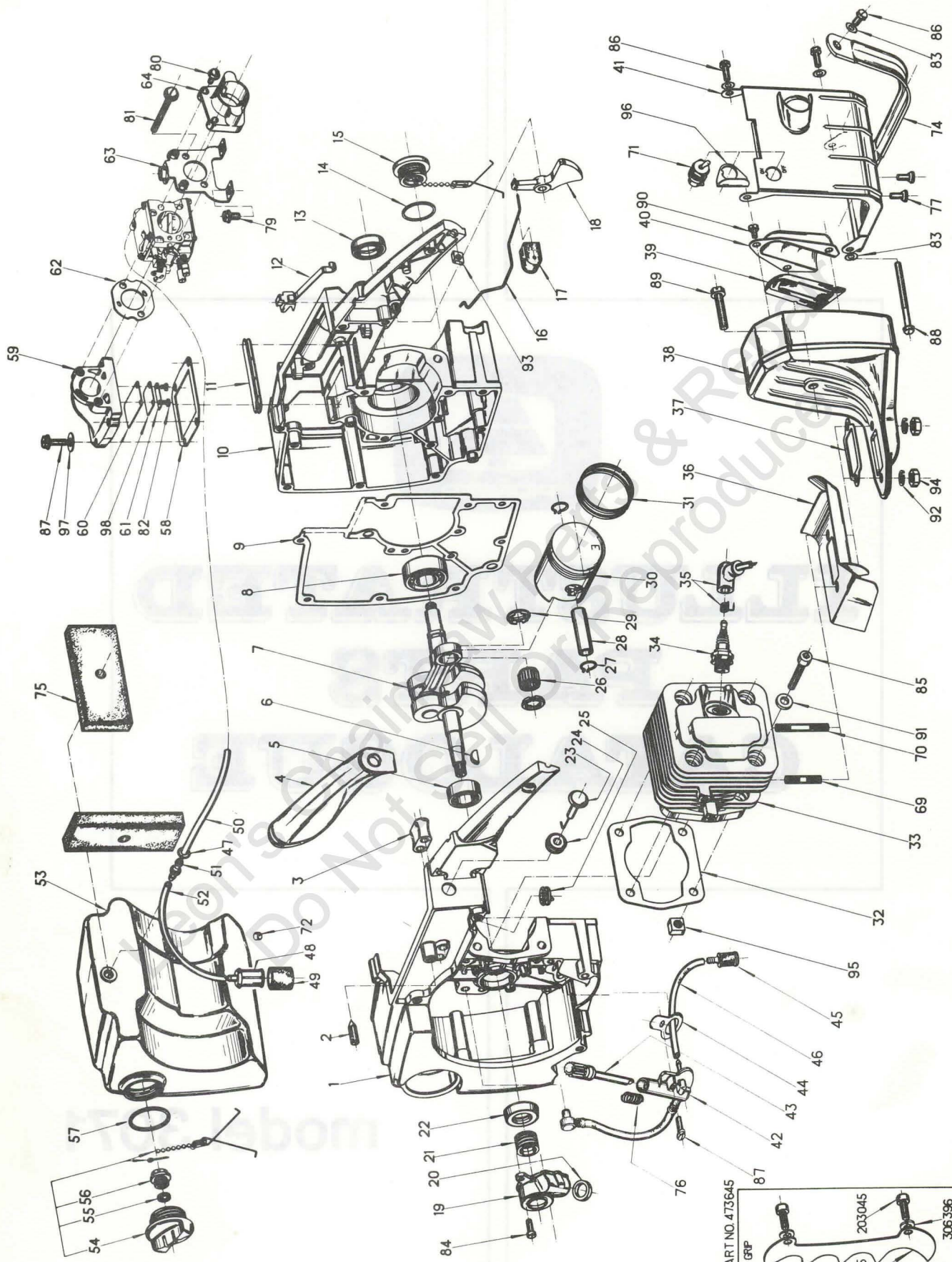

**ILLUSTRATED  
PARTS  
CATALOGUE**

**model 3071**





KIT - PART NO. 473645

PIVOT GRP

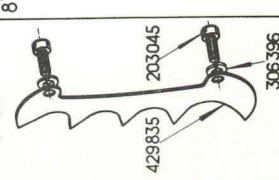

PIONEER MODEL 3071

REF. NO.	PART NO.	NAME OF PART	QTY. PER ASSY.	REF. NO.	PART NO.	NAME OF PART	QTY. PER ASSY.	REF. NO.	PART NO.	NAME OF PART	QTY. PER ASSY.
1	473549	C'CASE HALF ASSY.,-Mag. side .	1	34	428006	SPARK PLUG (Packaged) . . . . .	1	70	429606	STUD (1 3/4" Long), Cylinder . .	1
2	429890	SCREW, Idle adjustment . . . . .	1	35	580339	SPARKY COVER ASSY. . . . .	1	71	473965	ON-OFF SWITCH . . . . .	1
3	430019	GROMMET, Carburetor Adj. . . . .	1	36	429641	SHROUD, Muffler . . . . .	1	72	303473	CLAMP - HOSE - Fuel Pickup . . .	1
4	429646	GRIP, Rear handle . . . . .	1	37	429642	GASKET, Muffler . . . . .	1	74	429647	REAR HANDLE BRACE . . . . .	1
5	427849	MAIN BEARING, - Mag. side . . . .	1	38	473584	MUFFLER ASSEMBLY . . . . .	1	75	429930	SEALING PAD, Airbox . . . . .	2
6	429481	KEY, Flywheel . . . . .	1	39	429789	SCREEN, Spark arrestor . . . . .	1	76	430031	SPRING - Oil Pump . . . . .	1
7	473529	CRANKSHAFT & CON. ROD ASSY	1	40	429788	COVER, Muffler . . . . .	1	77	307163	SCREW, Handle brace . . . . .	2
8	425066	MAIN BEARING, Drive side . . . .	1	41	473686	CYLINDER SHROUD ASSY. . . . .	1	79	429693	SCREW, Carburetor bracket . . . .	2
9	429609	GASKET, Crankcase . . . . .	1	42	473825	OIL PUMP BODY & LINE ASSY. . . .	1	80	311516	SCREW, Blowback tube . . . . .	2
10	473548	C'CASE HALF ASSY., Drive side . .	1	43	473563	PLUNGER, Automatic oiler . . . . .	1	81	430020	SCREW, Carburetor to elbow . . . .	2
11	429820	INSULATOR, Crankcase . . . . .	1	44	429774	GASKET, Oil pump base . . . . .	1	82	428335	SCREW, Self tap. - Reed . . . . .	2
12	473552	THROTTLE LOCK ASSY. . . . .	1	45	470986	OILER PICKUP ASSY. . . . .	1	83	303916	LOCKWASHER - Cyl. Shroud . . . .	4
13	425076	SEAL, Drive side . . . . .	1	46	429804	HOSE, Oiler pick up . . . . .	1	84	310859	SCREW, Oil pump cover . . . . .	2
14	429322	"O" RING, Oil Cap . . . . .	1	47	305857	"O" RING - Connector . . . . .	1	85	317008	SCREW, Cylinder base . . . . .	4
15	473732	OIL CAP ASSY. . . . .	1	48	471419	FUEL PICKUP ASSY. . . . .	1	86	429694	SCREW, Cylinder shroud to c'case	2
16	429611	THROTTLE LINK . . . . .	1	49	429904	FELT . . . . .	1			Brace to rear handle . . . . .	1
17	429803	GROMMET, Throttle link . . . . .	1	50	429970	FUEL LINE, Tank to carburetor . .	1			(* see also item no. 180)	
18	429610	THROTTLE TRIGGER . . . . .	1	51	473772	CONNECTOR, Fuel tank . . . . .	1	87	429695	SCREW, Oil pump	1
19	429657	COVER, Oil pump . . . . .	1	52	429677	FUEL PICKUP LINE . . . . .	1			Elbow to c'case . . . . .	4
20	429816	DUST SEAL, Oil pump . . . . .	1	53	429796	FUEL TANK . . . . .	1			(* see also item no. 181)	
21	429655	WORM, Pump drive . . . . .	1	54	473654	GAS CAP ASSY. COMPLETE . . . . .	1	88	429699	SCREW, Cylinder shroud to	1
22	428746	SEAL, Mag. side . . . . .	1	55	429845	FILTER, Gas Cap . . . . .	1			c'case (* see also item no. 184)	
23	430022	CHOKE KNOB & WIRE ASSY. . . . .	1	56	473655	RETAINER & VALVE ASSY. . . . .	1	89	429698	SCREW, Muffler to cylinder . . . .	1
24	429650	GROMMET, Choke knob . . . . .	1	57	429946	Gas cap . . . . .	1	90	311516	SCREW, Cover to muffler . . . . .	3
25	428352	GROMMET, Lead to cond. &	1	58	429897	"O" RING, Gas Cap . . . . .	1	91	552743	WASHER, Cylinder . . . . .	4
26	429538	H.T. Coil . . . . .	1	59	473808	GASKET, Reed to crankcase . . . .	1	92	306396	LOCKWASHER, Muffler . . . . .	2
27	429548	BEARING, Wrist pin . . . . .	1	60	429965	ELBOW & REED ASSY. . . . .	1	93	306542	NUT, Rear handle . . . . .	1
28	429546	RETAINER, Wrist pin . . . . .	2	61	428127	(includes Parts ■) . . . . .	1	94	306397	NUT, Muffler . . . . .	2
29	429547	WRIST PIN . . . . .	1	62	427888	■ REED . . . . .	1	95	315381	NUT, Cylinder . . . . .	4
30	429547	THRUST WASHER . . . . .	2	63	473805	■ RETAINER PLATE	1	96	429931	SWITCH GUARD . . . . .	1
31	473403	PISTON ASSY. . . . .	1	64	430018	(■ see also item no. 82, 98)	1	97	306561	WASHER - Reed elbow . . . . .	4
32	471656	PISTON RING SET . . . . .	1	65	426642	GASKET, Carb. to elbow . . . . .	1	98	429966	■ REED STIFFENER . . . . .	1
33	429608	GASKET, Cylinder base . . . . .	1	66		BRACKET ASSY., Carburetor . . . .	1				
	473566	CYLINDER & STUD ASSY. . . . .	1	67		BLOW BACK TUBE . . . . .	1				
		(*includes parts 69 & 70)	1	68		STUD (1 3/16" Long), Cylinder . .	1				

■ Indicates parts included in preceding assembly.

\* Fastenings used in this application are also on page 4.

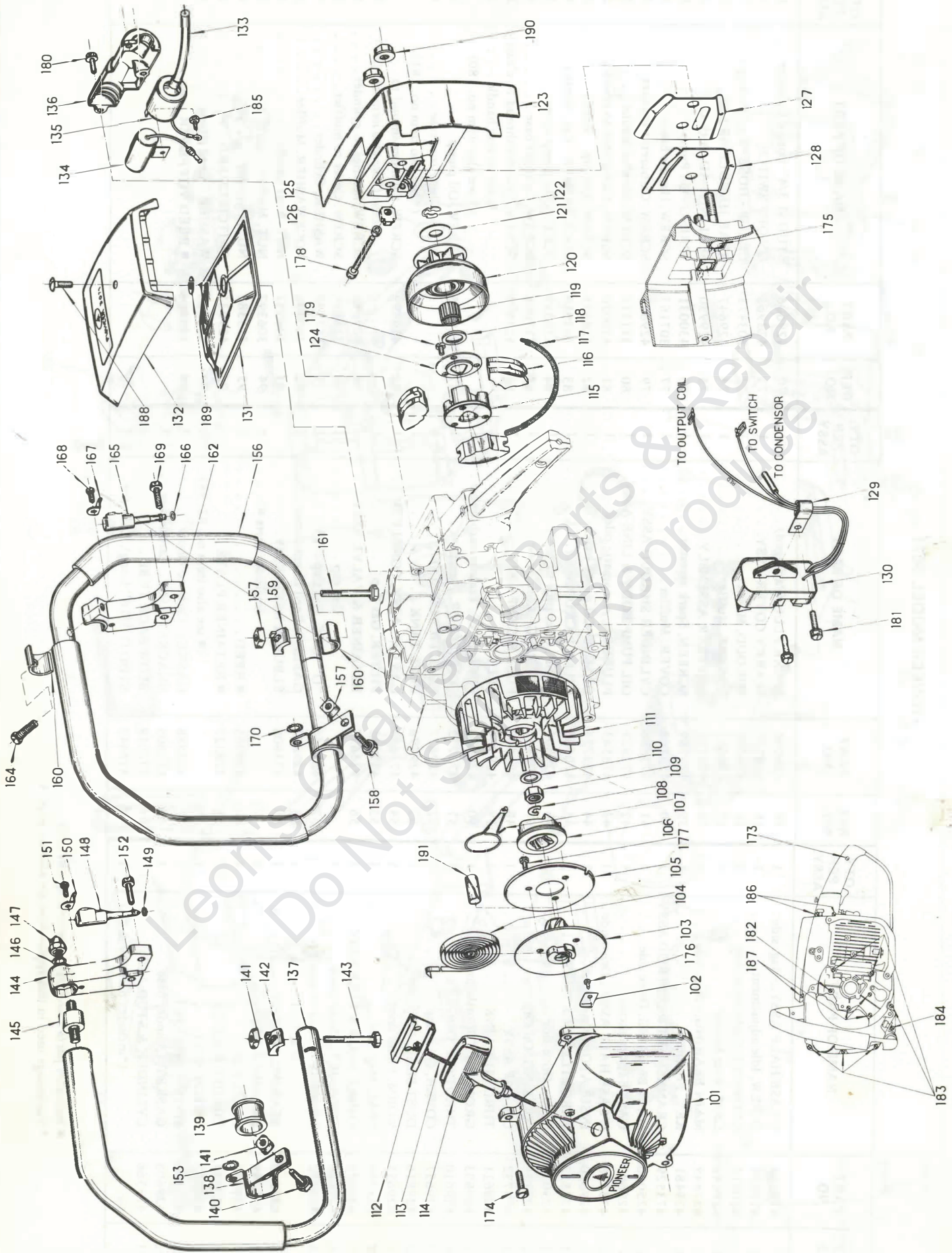

PIONEER MODEL 3071

REF. NO.	PART NO.	NAME OF PART	QTY. PER ASSY.	REF. NO.	PART NO.	NAME OF PART	QTY. PER ASSY.	REF. NO.	PART NO.	NAME OF PART	QTY. PER ASSY.
101	473822	BLOWER COVER ASSY. . . . .	1	132	430014	AIR FILTER COVER . . . . .	1	160	429981	MOUNTING STRAP, front handle .	2
102	430013	STOP - Friction Yoke . . . . .	1	133	429682	H. T. CABLE . . . . .	1	161	304628	SCREW, front handle, strut side . . . . .	1
103	429894	STARTER PULLEY . . . . .	1	134	429681	CONDENSOR . . . . .	1	162	429982	BRACKET, front handle . . . . .	1
104	604257	SPRING, Starter pulley . . . . .	1	135	473576	OUTPUT COIL ASSY. . . . .	1	163	429995	SCREW, front handle . . . . .	1
105	429243	PLATE, Starter pulley . . . . .	1	136	473731	COVER ASSY., Condensor & Output coil . . . . .	1	164	473630	INDICATOR ASSY. . . . .	1
106	429892	PINION . . . . .	1					165	304598	"O" RING, indicator, bracket . . . . .	1
107	473637	FRICITION YOKE & SLEEVE ASSY., Pinion . . . . .	1					166	429810	CLAMP, Oil indicator . . . . .	1
108	429246	RETAINING RING . . . . .	1	137	473555	SEMI-WRAP HANDLE FRONT HANDLE ASSY. Semi wrap	1	167	310859	SCREW, Clamp to bracket . . . . .	1
109	404837	NUT, Flywheel . . . . .	1	138	473674	CLAMP ASSY., Front handle . . . . .	1	168	429695	SCREW, front handle bracket . . . . .	2
110	429851	WASHER, Flywheel . . . . .	1	139	429634	MOUNTING SLEEVE, front handle . . . . .	1	169	303916	LOCKWASHER - Front Hdl. Bracket . . . . .	1
111	473574	FLYWHEEL ASSY. . . . .	1	140	306772	SCREW, front handle, blower side .	1	170			
112	429540	ANCHOR . . . . .	1	141	315381	NUT, Front handle . . . . .	2	173	307466	SCREW, Rear Handle . . . . .	1
113	429278	STARTER CORD . . . . .	1	142	429842	SPACER, Front handle . . . . .	1	174	510195	SCREW, Blower cover . . . . .	3
114	427370	STARTER HANDLE . . . . .	1	143	304628	SCREW, Front handle, strut side .	1	175	427659	STUD, Cutter bar . . . . .	2
115	429602	CLUTCH DRIVER . . . . .	1	144	429629	BRACKET, front handle . . . . .	1	176	429688	SCREW, Stop - Friction Yoke . . . . .	1
116	427187	CLUTCH SHOE . . . . .	3	145	377582	SHOCK ABSORBER, front handle	1	177	602821	SCREW, Pulley . . . . .	3
117	426964	SPRING, Clutch . . . . .	1	146	304202	LOCKWASHER - front handle . . . . .	1	178	429638	SCREW, Chain tensioner . . . . .	1
118	429551	THRUST WASHER, Inner clutch . . . . .	1	147	429662	ACORN NUT, front handle . . . . .	1	179	306492	SCREW, Clutch driver . . . . .	3
119	429557	BEARING, Clutch drum . . . . .	1	148	473630	INDICATOR ASSY. . . . .	1	180	429694	SCREW, Coil & condensor cover (* see also item no. 86) . . . . .	3
120	473547	CLUTCH DRUM & SPROCKET ASSY., (with bearing) . . . . .	1	149	304598	"O" RING, Indicator, bracket . . . . .	1	181	429695	SCREW - Charge & trigger cir. assy. (* see also item no. 87, 152, 169)	2
121	429550	THRUST WASHER, Outer clutch . . . . .	1	150	429810	CLAMP, Oil indicator . . . . .	1	182	429697	SCREW, Crankcase . . . . .	1
122	430322	RETAINING CLIP - Clutch . . . . .	1	151	310859	SCREW, Clamp to bracket . . . . .	1	183	429698	SCREW, Crankcase . . . . .	6
123	473557	STRUT ASSY. . . . .	1	152	429695	SCREW, front handle bracket . . . . .	2	184	429699	SCREW, Crankcase (* see also item no. 88) . . . . .	1
124	429636	RETAINING WASHER, Clutch driver . . . . .	1	153	303916	LOCKWASHER From handle bracket	1	185	311516	SCREW, Condensor to crankcase .	1
125	425672	PIN, Chain tensioner . . . . .	1					186	429696	SCREW, Rear handle . . . . .	2
126	429637	STOP, Chain tensioner . . . . .	1					187	429701	SCREW, Crankcase . . . . .	4
127	429660	OUTER GUIDE PLATE, Bar . . . . .	1	156	473774	FULL WRAP HANDLE FRONT HANDLE ASSY. full wrap	1	188	430021	SCREW, Air filter cover . . . . .	1
128	429659	INNER GUIDE PLATE, Bar . . . . .	1	157	315381	NUT, front handle . . . . .	2	189	307566	GASKET, Air filter cover . . . . .	1
129	429799	CLAMP, Ignition wires . . . . .	1	158	300977	SCREW, front handle blower side . . . . .	1	190	429661	NUT, Stut . . . . .	2
130	473575	CHARGE & TRIGGER CIRCUIT ASSY. . . . .	1	159	429842	SPACER, front handle . . . . .	1	191	429895	NYLINED BEARING - Pulley . . . . .	1
131	430015	AIR FILTER ELEMENT . . . . .	1								

\* Fastenings used in this application are also listed on page 2.

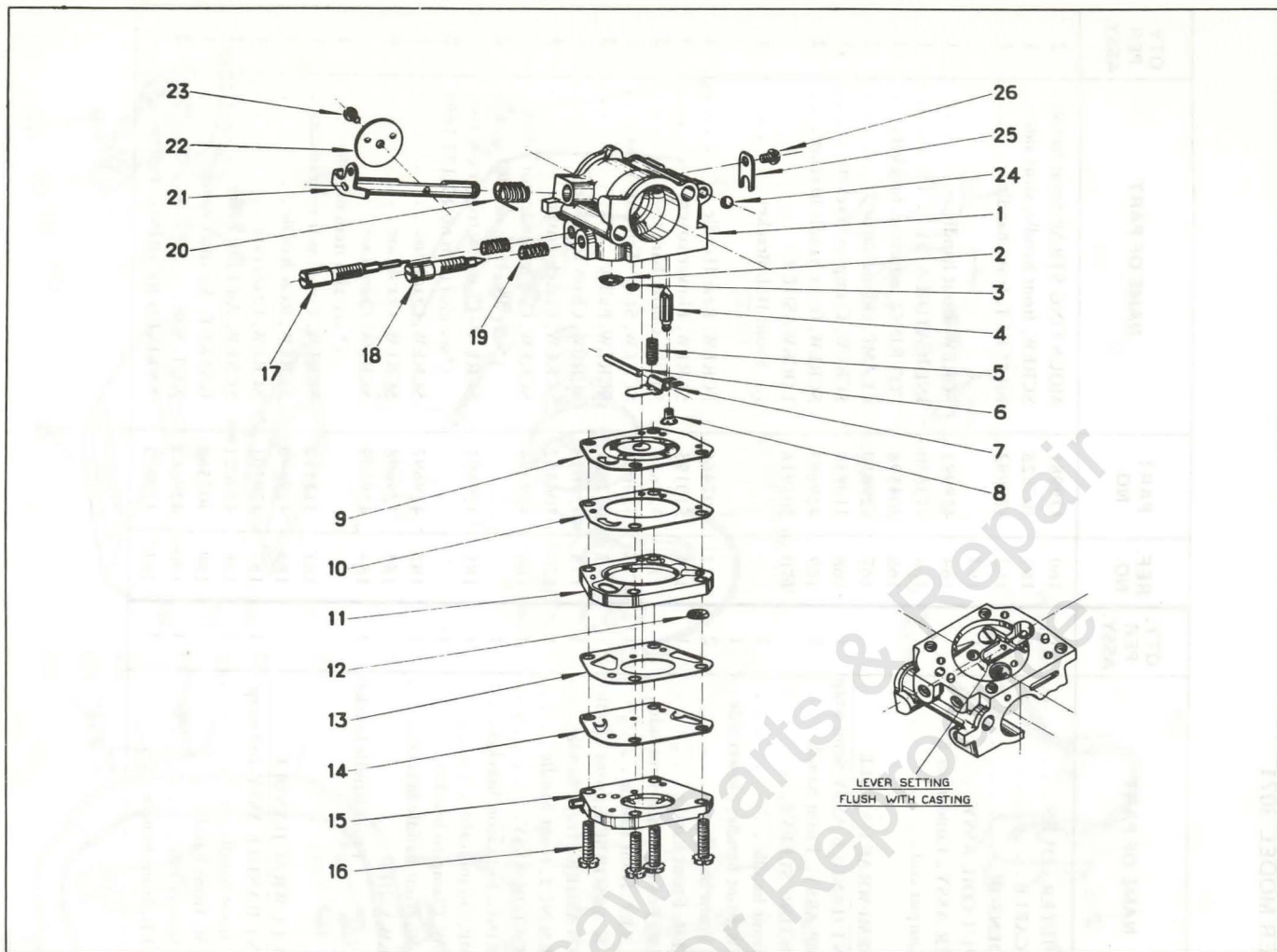

OMC CARBURETOR

PIONEER MODEL 3071

REF. NO.	PART NO.	NAME OF PART	QTY. PER ASSY.	REF. NO.	PART NO.	NAME OF PART	QTY. PER ASSY.
1	473462	CARBURETOR ASSY.COMPLETE	1	14	429709	PUMP, Diaphragm . . . . .	1
2	316991	EXPANSION PLUG, Idle . . . . .	1	15	473760	COVER ASSY., Fuel Pump . . . . .	1
3	316990	EXPANSION PLUG, H.S. . . . .	1	16	312475	SCREW, Cover to body . . . . .	4
4	429711	INLET VALVE . . . . .	1	17	473699	NEEDLE VALVE ASSY.,Low speed	1
5	429855	SPRING, Control lever . . . . .	1	18	429715	NEEDLE VALVE, High speed . . . . .	1
6	429757	HINGE PIN, Control lever . . . . .	1	19	310393	SPRING, Needle valve . . . . .	2
7	429713	LEVER, Inlet Control . . . . .	1	20	429720	SPRING, Throttle return . . . . .	1
8	317267	SCREW, Hinge pin . . . . .	1	21	473581	THROTTLE SHAFT ASSY. . . . .	1
9	473580	DIAPHRAGM ASSY. . . . .	1	22	429712	THROTTLE VALVE . . . . .	1
10	429719	GASKET, Metering diaphragm . . . . .	1	23	312852	SCREW, Throttle valve . . . . .	1
11	429707	COVER, Metering diaphragm . . . . .	1	24	602641	LEAD SHOT No.2 (.150 DIA). . . . .	1
12	429292	SCREEN, Cover . . . . .	1	25	310942	RETAINING CLIP, Throttle shaft	1
13	429710	GASKET, Pump diaphragm . . . . .	1	26	202589	SCREW, Retaining clip . . . . .	1

OMC TYPE CARBURETOR USED ON MODELS UP TO SERIAL NO. 696730

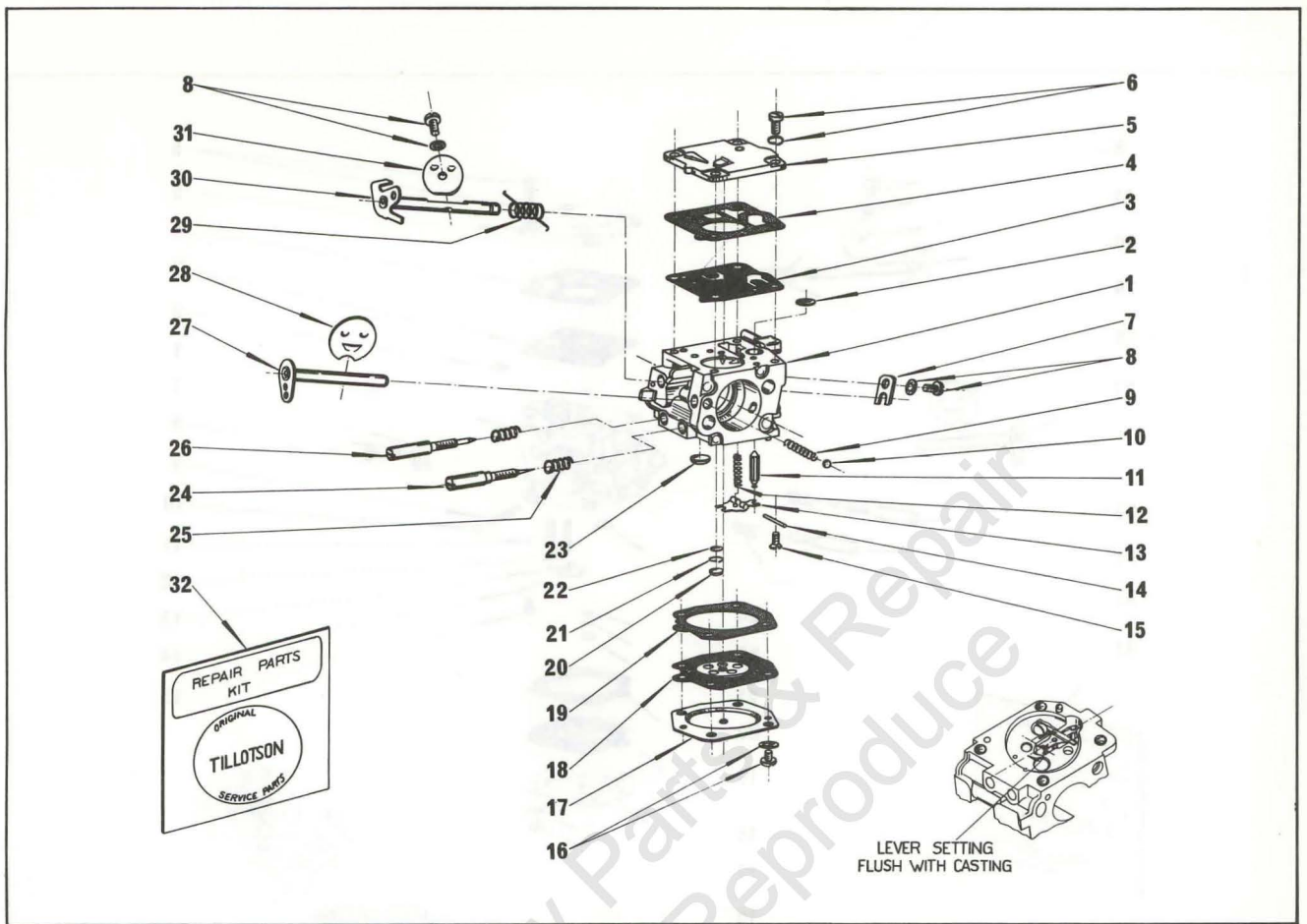

TILLOTSON HS-116A

PIONEER MODEL 3071

REF. NO.	PART NO.	NAME OF PART	QTY. PER ASSY.	REF. NO.	PART NO.	NAME OF PART	QTY. PER ASSY.
1	473806	CARBURETOR ASSY., Complete	1	17	427956	COVER, Diaphragm . . . . .	1
2	427951	* SCREEN . . . . .	1	18	471374	*DIAPHRAGM ASSY. . . . .	1
3	427941	* DIAPHRAGM, Fuel pump . . .	1	19	427950	GASKET, Diaphragm metering . .	1
4	427940	GASKET, Fuel Pump . . . . .	1	20	427944	* PLUG, 7/32 dia. Welch . . . . .	1
5	427939	COVER, pump . . . . .	1	21	427943	RING, retaining . . . . .	1
6	427955	SCREW & LOCKWASHER (6-32 x 3/8) . . . . .	4	22	427942	SCREEN . . . . .	1
7	310942	CLIP . . . . .	1	23	427948	*PLUG, 11/32 dia. welch . . . . .	1
8	427947	*SCREW & LOCKWASHER (4-40 x 3/16) . . . . .	2	24	427960	* SCREW, main adjustment . . .	1
9	425450	SPRING, Choke friction . . . . .	1	25	425449	* SPRING, adj. screw . . . . .	2
10	428452	BALL 5/32 dia. steel . . . . .	1	26	427959	* SCREW, Idle adjustment . . . .	1
11	427952	* NEEDLE, Inlet . . . . .	1	27	473817	SHAFT & LEVER, Choke . . . . .	1
12	426922	* SPRING, Tension . . . . .	1	28	428451	SHUTTER, Choke . . . . .	1
13	427953	* LEVER, Inlet valve control . . .	1	29	427961	* SPRING, Throttle return . . . .	1
14	427954	* PIN, Fulcrum . . . . .	1	30	473581	SHAFT & LEVER, Throttle . . . .	1
15	427962	* SCREW, (4-40 x 5/16) . . . . .	1	31	429712	SHUTTER THROTTLE . . . . .	1
16	426145	SCREW & LOCKWASHER . . . . .	4	32	471497	REPAIR PARTS KIT (Includes parts marked *). . . .	1

TILLOTSON CARBURETOR MODEL HS-116A USED ON MODEL SHOWING SERIAL NO. 696730 to 753478

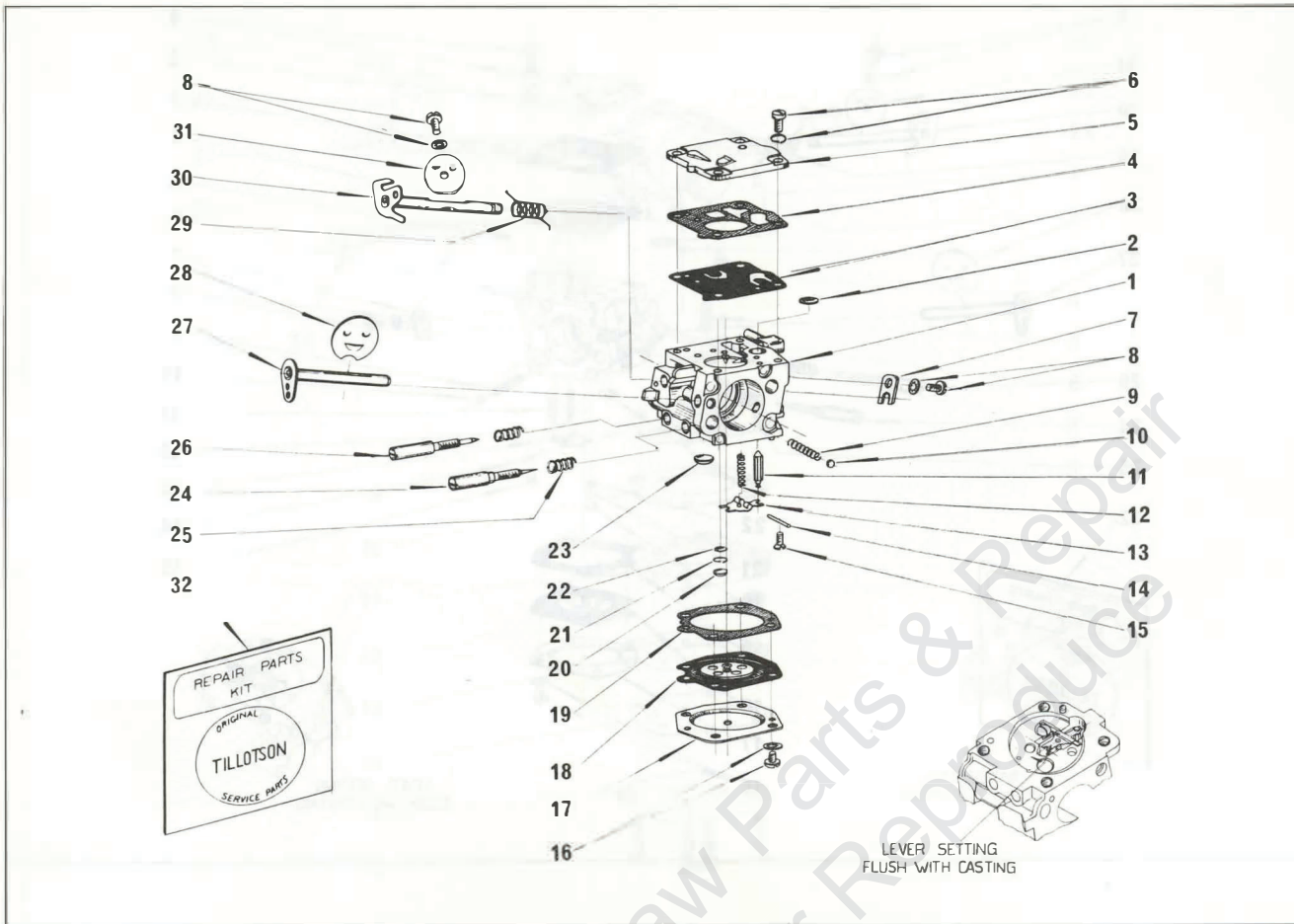

TILLOTSON HS-116B  
PIONEER MODEL 3071

REF. NO.	PART NO.	NAME OF PART	QTY. PER ASSY.	REF. NO.	PART NO.	NAME OF PART	QTY. PER ASSY.
1	473868	CARBURETOR ASSY. COMPLETE	1	16	426145	SCREW & LOCKWASHER . . . .	4
2	427951	* SCREEN . . . . .	1	17	427956	COVER, Diaphragm . . . . .	1
3	427941	* DIAPHRAGM, Fuel pump . . . .	1	18	471374	* DIAPHRAGM ASSY. . . . .	1
4	427940	GASKET, Fuel Pump . . . . .	1	19	427950	GASKET, Diaphragm metering . .	1
5	427939	COVER, Pump . . . . .	1	20	427944	* PLUG, 7/32 dia. Welch . . . . .	1
6	427955	SCREW & LOCKWASHER (6-32 x 3/8) . . . . .	4	21	427943	RING, retaining . . . . .	1
7	427957	CLIP . . . . .	1	22	427942	SCREEN . . . . .	1
8	427947	* SCREW & LOCKWASHER (4-40 x 3/16) . . . . .	2	23	427948	* PLUG, 11/32 dia. welch . . . . .	1
9	425450	SPRING, Choke friction . . . . .	1	24	430278	SCREW, main adjustment . . . . .	1
10	428452	BALL 5/32 dia. steel . . . . .	1	25	425449	* SPRING, Adj. screw . . . . .	2
11	427952	* NEEDLE, Inlet . . . . .	1	26	430277	SCREW, Idle adjustment . . . . .	1
12	426922	* SPRING, Tension . . . . .	1	27	473817	SHAFT & LEVER, Choke . . . . .	1
13	427953	* LEVER, Inlet valve control . . .	1	28	428451	SHUTTER, Choke . . . . .	1
14	427954	* PIN, Fulcrum . . . . .	1	29	427961	* SPRING, Throttle return . . . .	1
15	427962	* SCREW, (4-40 x 5/16) . . . . .	1	30	473957	SHAFT & LEVER, Throttle . . . .	1
				31	430279	SHUTTER THROTTLE . . . . .	1
				32	474115	REPAIR PARTS KIT (Includes parts marked *) . . . .	1

TILLOTSON CARBURETOR MODEL HS-116B USED ON MODELS SHOWING SERIAL NO. 753479 THRU.