

ILLUSTRATED PARTS LIST

MODEL NAME	SERIAL NUMBER PREFIX	MODEL
TITAN 7	12-	600171-02

McCulloch products are identified by a model number (in this instance 600171) followed by a suffix number (02). Suffix numbers denote variations in parts or assemblies used in the manufacture of this product.

Illustrated Parts Lists (IPLs) contain a PART NUMBER, DESCRIPTION, UNITS per assembly and STOCKING CODE for each part.

Stocking Codes are:

- A- Dealer stocked. Fast to medium moving part.
- B- Distributor stocked. Medium to slow moving part.
- C- Factory stocked. Slow moving part.
- T- Indicates a McCulloch service tool.

NOTE: The following explains symbols/footnotes in this IPL:

- (-) A dash preceding a PART NUMBER indicates that it is a new part number, different from the one listed in the previous IPL for this unit.
- (.) One or more dots (. Spring, Starter) preceding a part DESCRIPTION indicates the part is included in the kit or assembly described directly above the dot(s).
- (-- --) If four dashes appear in place of a PART NUMBER, the part is not available individually but is included in the next higher assembly or subassembly.
- ① ② Circled numbers preceding a DESCRIPTION footnote the part or assembly to additional information on the page.
- (*) An asterisk draws attention to general information.

The policy of McCulloch Corporation is one of continual improvement in design, manufacturing and engineering advancement wherever possible to assure still finer power tools. Hence, specifications, equipment colors, design and manufacturer's suggested list prices are subject to change without notice. McCulloch Corporation reserves the right to make such changes without prior notification or obligation to backfit or supply backfit components for units previously shipped.

JANUARY 1994

McCULLOCH
TITAN 7
CHAIN SAW

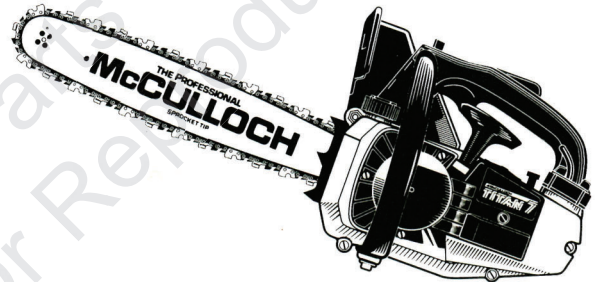

CONTENTS

	PAGE
FIGURE 1 General Assembly	2
FIGURE 2 Chain Brake Assembly	3
FIGURE 3 Powerhead Assembly	4
FIGURE 4 Handle Assembly	5
FIGURE 5 Carburetor Assembly	6
Bar and Chain Information	7
Specifications	7
Service Tools	7

McCULLOCH®

P.O. Box 11990 Tucson, Arizona 85734

211406

FIGURE 1

GENERAL ASSEMBLY

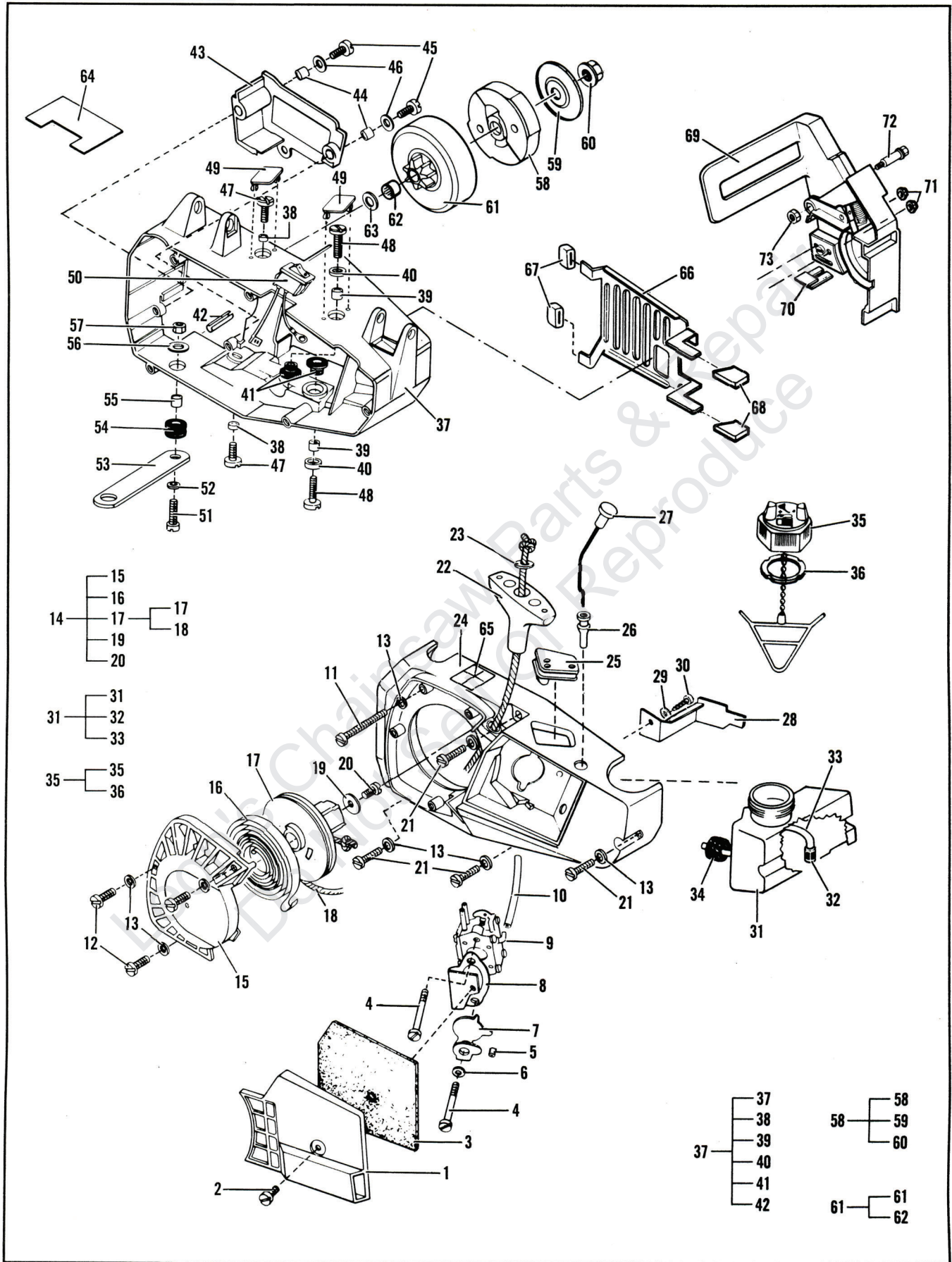

GENERAL ASSEMBLY

FIGURE 1

ITEM NO.	STK. CODE	PART NUMBER	DESCRIPTION	UNITS PER ASY.
1	C	229314	Cover, Air Filter	1
2	C	229342	Screw, M5 x 40 (6-9 in. lb. torque)	1
3	B	229343	Filter, Air	1
4	C	235244	Screw, M5 x 45 (30-40 in. lb. torque)	2
5	B	213420	Spacer	1
6	A	216591	Washer, Flat M5	1
7	B	213411	Plate, Choke	1
8	B	215455	Bracket, Choke	1
9	FIGURE 5		Carburetor Assembly	
10	A	213542-01	Hose, Pulse	1
11	B	229340	Screw, M4 x 50 (25-35 in. lb. torque)	1
12	B	229861	Screw, M4 x 14 (30-40 in. lb. torques)	3
13	B	235612	Washer	8
14	C	229633	Starter Assembly	1
15	C	223361	. Housing Assembly	1
16	A	83078	. Spring, Rewind	1
17	A	301253	. Kit, Drum/Rope Assy.	1
18	A	83203	.. Rope, Starter 32"	1
19	A	68497	. Washer	1
20	A	110041	. Screw, 8-32 x .50	1
21	B	229653	Screw, M4 x 25 (25-35 in. lb. torque)	4
22	A	87851	Handle, Starter	1
23	A	223944	Bushing, Starter	1
24	C	229339	Housing	1
25	C	229358	Grommet, Carb. Housing	1
26	C	229357	Grommet, Choke	1
27	C	229418	Choke/Rod Assembly	1
28	C	229594	Baffle	1
29	B	235612	Washer	1
30	C	229632	Screw, Self-tapping	1
31	C	229345	Fuel Tank	1
32	A	215714	. Pickup, Fuel	1
33	C	229743	. Hose, Fuel	1
34	B	90869	Filter, Vent	1
35	A	216157	Cap, Fuel, Retained	1
36	A	94707	. Gasket, Fuel Cap	1

ITEM NO.	STK. CODE	PART NUMBER	DESCRIPTION	UNITS PER ASY.
37	C	240159	Shroud Assembly	1
38	B	229529	. Sleeve	2
39	B	229530	. Sleeve	2
40	B	229370	. Washer (Insulator)	2
41	C	229338	. Sleeve (Insulator)	2
42	C	235222	. Pin, Roll	1
43	C	300531	Cover, Oil Pump	1
44	B	229121	Bushing	2
45	B	229861	Screw, M4 x 14 (25-35 in. lb. torque)	2
46	B	235612	Washer	2
47	B	229368	Screw (70-80 in. lb. torque)	2
48	B	229369	Screw (70-80 in. lb. torque)	2
49	B	229438	Cover	2
50	B	229445	Switch, Ignition	1
51	C	235239	Screw, M5 x 20 (35-40 in. lb. torque)	2
52	A	216591	Washer, Flat M5	3
53	C	229232	Link Plate	1
54	A	110989	Grommet	2
55	A	93057	Spacer, Mount	2
56	A	120045	Washer, M5	2
57	A	235642	Nut, M5	2
58	A	213278	Kit, Clutch Assembly	1
59	B	94243	. Plate, Dust	1
60	A	94244	. Nut, Clutch (160-170 in. lb. torque)	1
61	A	95646	Drum/Sprocket/Bearing Assy (.375)	1
	B	235864	Drum/Sprocket Assy. (.325)	1
62	A	91117	. Bearing	1
63	B	215259	Washer, Sprocket	1
64	C	223297	Label, Instruction	1
65	B	219058	Label, Safety	1
66	B	229432	Shield, Muffler	1
67	B	229434	Support, Plastic	2
68	B	229435	Support, Plastic	2
69	FIGURE 2		Chain Brake Assembly	
70	C	229494	Plate, Seal	1
71	A	120029	Nut, M6.3 x 1.0 FLG	2
72	C	229134	Bolt, Pivot	1
73	B	235912	Nut	1

CHAIN BRAKE ASSEMBLY

FIGURE 2

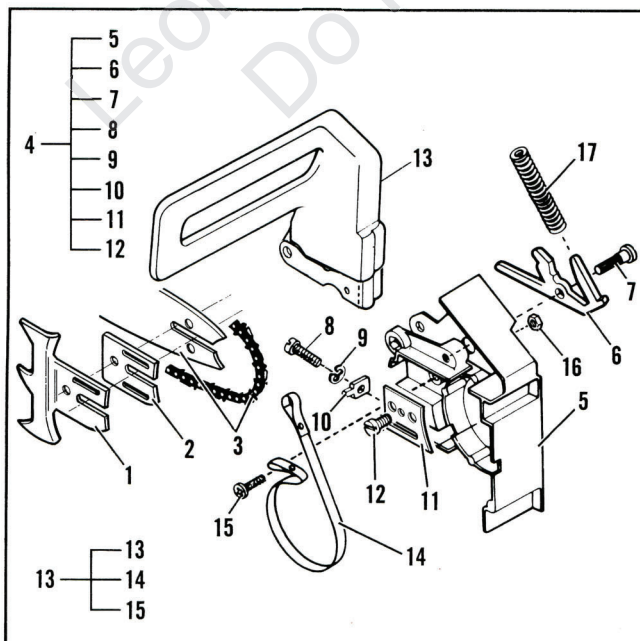

ITEM NO.	STK. CODE	PART NUMBER	DESCRIPTION	UNITS PER ASY.
1	A	223087	Spike	1
2	B	240028	Spacer, Bar Pad	1
3		PAGE 8	Bar and Chain	
4	C	246090	Chain Brake Assembly	1
5	C	240026	. Clutch Cover	1
6	C	235563	. Brake Latch	1
7	C	235075	. Pivot, Latch	1
8	B	229691	. Screw, Adjusting	1
9	B	235811	. C-Clip	1
10	B	229690	. Nut, Bar Adjustment	1
11	B	240028	. Plate, Bar	1
12	C	229082	. Screw	1
13	B	229228	Brake Lever/Band Assembly	1
14	B	235073	. Band, Brake	1
15	C	235812	. Screw	1
16	B	235216	Nut, M5	1
17	C	229740	Spring, Compression	1

POWERHEAD ASSEMBLY

FIGURE 3

ITEM NO.	STK. CODE	PART NUMBER	DESCRIPTION	UNITS PER ASY.
1	C	222778	Flywheel/Pawl Assembly, FLI	1
2	B	216984	. Pin, Starter Pawl	2
3	A	216983	. Pawl, Starter	2
4	A	216982	. Spring, Starter Pawl	2
5	A	93469	. Washer, Starter Pawl	2
6	B	120112	Screw, M5 x .8 x 40 (44-55 in. lb. torque)	2
7	A	216591	Washer	3
8	B	301192	Ignition Assembly, FLI	1
9	C	236601	. Connector, Spark Plug	1
10	C	229680	. Boot, Spark Plug	1
11	B	215601	Manifold, Carburetor	1
12	A	92778	Gasket, Manifold	1
13	A	83859	Seal, C'shaft Oil	2
14	A	213282	Bearing, C'shaft	2
15	A	102164	Key, Flywheel	1
16	B	92750	Crankshaft	1
17	B	94135	Conn Rod/Bearing Asy	1
18	B	94654	. Screw, Connecting Rod	2
19	A	110984	. Bearing, Needle	1
20	A	68095	. Set, Needle Roller	1
21	A	94660	Piston Assembly	1
22	A	94136	. Set, Piston Rings	1
23	B	92836	. Pin, Piston	1
24	A	111026	. Ring, Snap, Internal	2
25	C	300532	Cylinder/C'case Assembly	1
26	A	92777	. Bolt, Bar	2
27	B	214356	Spacer, Baked	1
28	A	120098	Screw, Hex M5 x .8 x .18	1
29	B	93018	Spark Plug, RDJ8J	1
30	B	120097	Screw, Hex M5 x .8 x 25 (70-80 in. lb. torque)	4
31	B	92747	Flange, Carburetor	1
32	A	92746	Boot, Carburetor	1
33	A	95656	Eyelet	1
34	B	94302	Clip, Spring	1

ITEM NO.	STK. CODE	PART NUMBER	DESCRIPTION	UNITS PER ASY.
35	A	219990-01	Kit, Pump Assembly, Oiler	1
36	A	216426-01	. Oil Pump Repair Kit	1
37	C	216422	.. Eyelet	1
38	B	216423	.. Sleeve, Oil Pump	2
39	B	217765	.. Screw, Adjusting	1
40	B	83891	. Spring, Return	1
41	C	223651	. Piston Assembly, Oiler	1
42	A	105603	.. O-ring	1
43	B	93301	. Plunger	1
44	A	105614	. O-ring	1
45	B	93632	. Spring	1
46	A	215151	. Cap, Oil Pump	1
47	A	94115	. Valve, Oiler	1
48	B	215196	. Connector Hose	1
49	A	110653	O-ring	1
50	A	217168	Connector, Oil Pump (out)	1
51	C	93150	Bail	1
52	B	229348	Tank Assembly, Oil	1
53	C	229349	. Hose, Oil	1
54	A	225062	. Pickup, Oil	1
55	A	236321	. Grommet	1
56	C	228122	Pin, Cotter	1
57	C	229350	Oil Cap Assembly	1
58	C	229354	. Gasket, Oil Cap	1
59	A	213169	Nut, Hex Flange M8 (200-220 in. lb. torque)	1
60	C	223600	Muffler Assembly	1
61	B	223635	. Screw, Skt Hd 10-24 x .5	2
62	C	223597	. Cover, Deflector Assembly	1
63	C	216047	. Spacer	2
64	C	223826	. Screw, Pan Hd 6-32 x .875	1
65	A	215394	. Screw, Special	2
66	C	83407	. Screen, Spark Arrester	1
67	C	215410	. Body/Cover Assembly	1
68	C	223825	. Spacer, Muffler	1

HANDLE ASSEMBLY

FIGURE 4

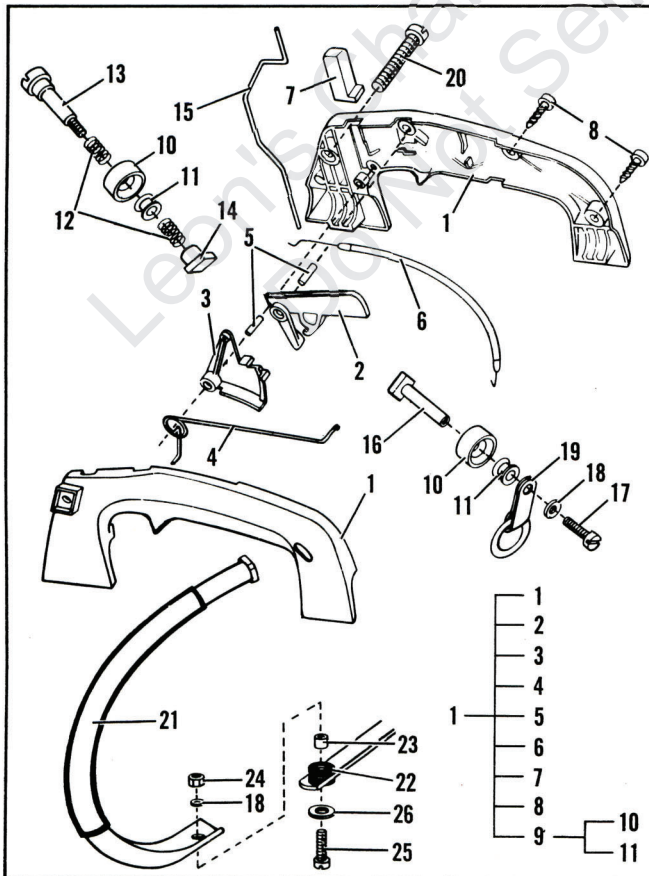

ITEM NO.	STK. CODE	PART NUMBER	DESCRIPTION	UNITS PER ASY.
1	C	229360	Top Handle Assembly	1
2	C	229317	. Trigger, Safety	1
3	C	229318	. Trigger, Throttle	1
4	C	229361	. Spring, Throttle	1
5	C	235605	. Pin	2
6	B	229362	. Wire Assembly, Throttle	1
7	C	229363	. Knob, Oiler	1
8	B	235205	. Screw	4
9	B	229225	. Mount Assembly	1
10	A	92704	.. Mount	2
11	A	94038	.. Hub, Mount	2
12	C	229284	Mount, Spring	2
13	C	229365	Bolt (15-20 in. lb. torque)	1
14	C	229366	Nut	1
15	B	229359	Rod, Oiler	1
16	C	229367	Sleeve	1
17	A	235207	Screw, M5 x 14 (15-20 in. lb. torque)	1
18	A	216591	Washer, Flat M5	3
19	C	322130	Ring Assembly	1
20	B	229654	Screw, M6 x 40	1
21	C	229433	Frame	1
22	A	110989	Grommet	2
23	A	93057	Spacer, Mount	2
24	A	235642	Nut M5	2
25	C	235239	Screw, M5 x 20 (25-30 in. lb. torque)	2
26	A	120045	Washer M5	2

FIGURE 5

CARBURETOR ASSEMBLY

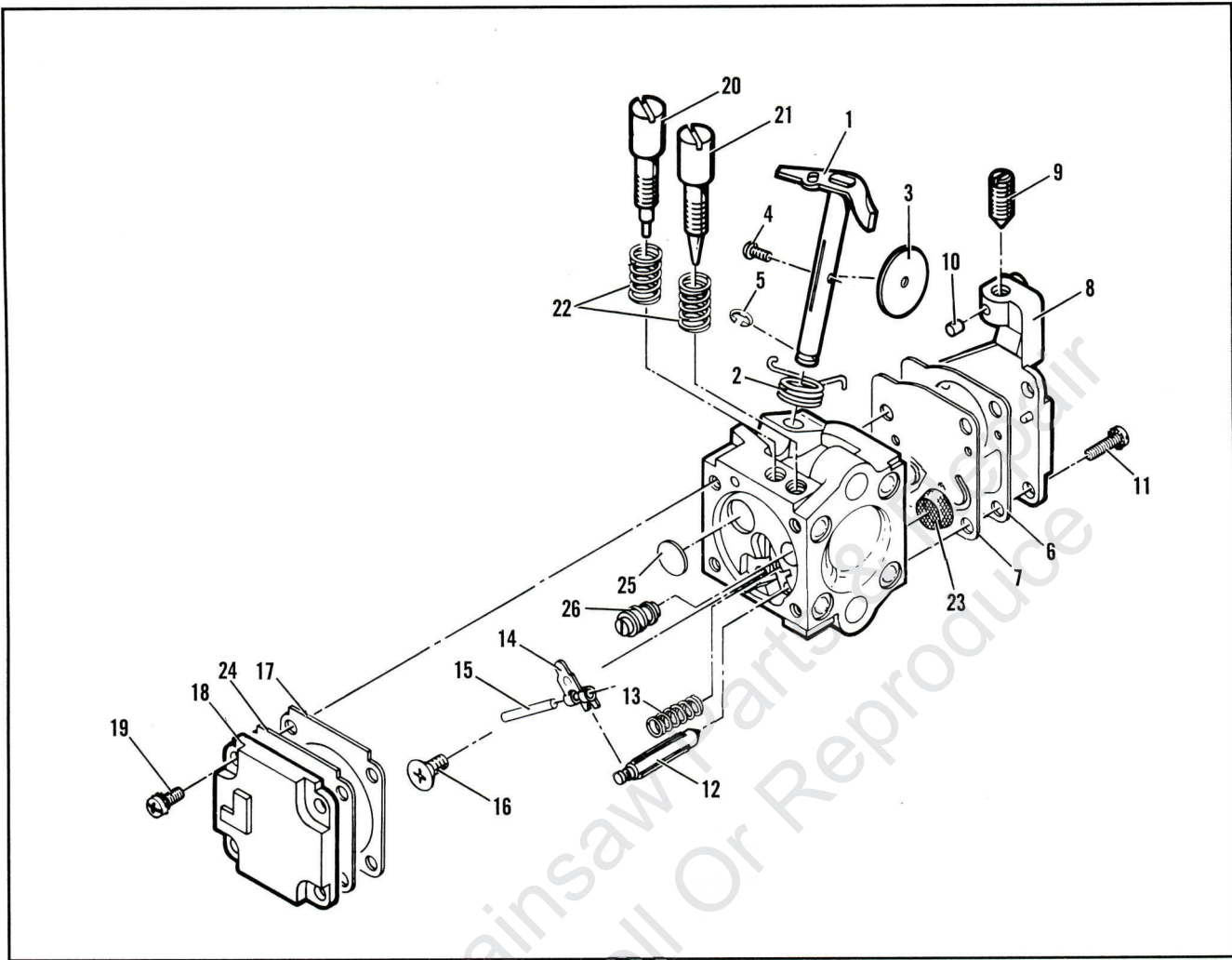

ITEM NO.	STK. CODE	PART NUMBER	DESCRIPTION	UNITS PER ASY.
	A	94496	Carburetor, Zama M2B	1
1	--	--	. Shaft Assembly, Throttle	1
2	--	--	. Spring, Throttle Return	1
3	--	--	. Plate, Throttle	1
4	--	--	. Screw, Plate (M3)	1
5	--	--	. Ring, 'E'	1
6	--	--	①②. Gasket, Pump	1
7	--	--	①②. Diaphragm, Pump	1
8	B	94206	. Cover Assembly, Pump	1
9	--	--	.. Screw, Idle Speed	1
10	--	--	.. Insert, Friction	1
11	--	--	① . Screw, Pump Cover (M3)	4
12	--	--	① . Needle, Inlet	1
13	--	--	① . Spring, Lever	1

ITEM NO.	STK. CODE	PART NUMBER	DESCRIPTION	UNITS PER ASY.
14	--	--	① . Lever, Inlet Needle	1
15	--	--	① . Pin, Lever	1
16	--	--	① . Screw, Lever Pin (M3)	1
17	--	--	①②. Diaphragm Assembly, Metering	1
18	--	--	. Cover, Diaphragm	1
19	--	--	. Screw, Diaphragm Cover (M3)	4
20	--	--	. Screw, Idle Adjust	1
21	--	--	. Screw, Main Adjust	1
22	--	--	. Spring, Needle	2
23	--	--	① . Screen, Filter	1
24	--	--	①②. Gasket, Metering Diaphragm	1
25	--	--	① . Plug, Welch	1
26	--	--	① . Orifice, Main Fuel	1

NOTE: Items shown are for identification and disassembly sequence purposes only. Components are not available separately unless a part number is listed before the part description.

① A 300460 Kit, Carburetor Rebuild (RB-1)
 ② B 300467 Kit, Gasket/Diaphragm (GND-1)

NOTE: Zama repair kits may contain additional components not relative to this unit. Always identify the part being replaced before installation. Discard any additional parts not shown above.

CARBURETOR INLET LEVER ADJUSTMENT AND SETTINGS
CARBURETOR INLET POP OFF - 7 - 8 PSI
INLET FLUSH WITH METERING CHAMBER FLOOR USING Z-GUAGE

BAR AND CHAIN INFORMATION

PART NUMBER	STK. CODE	BAR DESCRIPTION	PART NUMBER	STK. CODE	CHAIN DESCRIPTION	FILE PLATE	STK. CODE	ROUND FILE	STK. CODE
222987-01	B	12" Sprocket Tip	219223-12	A	MP370GLX48CL	219131-01	B	214217-01	B
222915-01	A	14" Sprocket Tip	214919-12	A	MP370GLX49CL				
222916-01	A	16" Sprocket Tip	219230-12	A	MP370GLX59CL				

SPECIFICATIONS

CYLINDER	Aluminum with Chrome Bore
DISPLACEMENT	2.1 c.i. (35 cc)
BORE and STROKE	1.5 in. (38mm) x 1.2 in. (30.5mm)
PISTON RINGS	2 Cast Iron Compression
MAIN BEARINGS	Needle
FUEL CAPACITY	11.2 oz. (330cc)
FUEL TYPE	Regular Grade, Leaded or Unleaded
FUEL/OIL MIXTURE	40:1 Using McCulloch Two-cycle Custom Lubricant
IDLE SPEED	2700 to 2900 RPM
CLUTCH ENGAGEMENT SPEED	3800 RPM
IGNITION	Electronic
CARBURETOR	Diaphragm Type with 2 Needle Adjustment
FUEL FILTER	Enclosed Felt
AIR FILTER	Felt
LAMINATION GAP	0.011 in. to 0.015 in. (0.3 to 0.4 mm)

SERVICE TOOLS

PART NUMBER	STOCK CODE	DESCRIPTION
215432	T	Tool, Pressure Test
91226	T	Wrench, Flywheel/Clutch
229667	C	Funnel, Oil

LOCTITE KIT

PART NUMBER	DESCRIPTION
322235	LOCTITE KIT
322236	. RETAINING COMPOUND 620 (10 ml)
322237	. THREAD LOCKER 242 (10 ml)
322238	. GASKET ELIMINATOR 518 (50ml)
322239	. BLACK MAX ADHESIVE 380 (1 oz)

FOR PERFORMANCE AND SAFETY REASONS USE **ONLY GENUINE**

McCULLOCH ACCESSORIES AND REPLACEMENT PARTS

McCULLOCH®



• MANUFACTURING • SALES • SERVICE •

P.O. Box 11990 • Tucson, AZ 85734

FOR WARRANTY OR SERVICE
CONTACT THE NEAREST
McCULLOCH AUTHORIZED SERVICE CENTER
LISTED UNDER "SAWS"
IN YOUR TELEPHONE DIRECTORY
YELLOW PAGES.

IF FURTHER ASSISTANCE IS REQUIRED
CALL THIS TOLL-FREE HOT LINE.
PLEASE REFERENCE YOUR MODEL AND SERIAL NUMBER.

1-800-423-6302

IN ARIZONA:

1-800-221-6507

M-F 6:00 AM - 4:45 PM (MST)