

ILLUSTRATED PARTS LIST

MODEL NAMES	SERIAL NUMBER PREFIX	MODELS
TITAN 35	11-	600143-06
TITAN 40	11-	600144-04

McCulloch Chain Saws are identified by a model number (in this instance 600143 & 600144) followed by a suffix number (04 & 06 etc.). Suffix numbers denote variations in parts or assemblies used in the manufacture of this product.

Part numbers listed in this I.P.L. which have a circled number ① or numbers preceding the description, are used only on the model or models identified by a circled number ① or numbers.

Part numbers which have one or more dots (.) preceding their descriptions may be ordered individually, but they are also included in the kit or assembly whose description begins directly above the dot(s).

The policy of McCulloch Corporation is one of continual improvement in design, manufacturing and engineering advancement wherever possible to assure still finer power tools. Hence, specifications, equipment, colors, design and manufacturer's suggested list prices are subject to change without notice and McCulloch Corporation reserves the right to make such changes without prior notification or obligation to backfit or supply backfit components for units previously shipped from the factory.

AUGUST 1988

TITAN 35 / 40

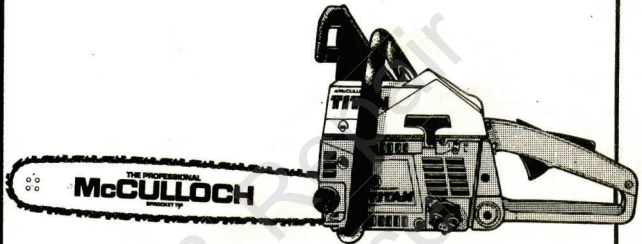

CONTENTS

	PAGE
FIGURE 1 General Assembly	2
FIGURE 2 Starter Assembly	3
FIGURE 3 Handle Assemblies	4
FIGURE 4 Carburetor Assemblies	5
FIGURE 5 Powerhead Assembly	6
FIGURE 6 Engine Specifications	8
FIGURE 7 Bar	8
FIGURE 8 Service Tools	8

TO ANSWER SERVICE-RELATED
QUESTIONS AND TO SOLVE COMMON
CONSUMER PROBLEMS QUICKLY,
CALL THIS TOLL-FREE HOT-LINE:

(800) 423-6302

IF LOCATED IN ARIZONA, CALL
COLLECT:

(602) 453-3681

McCULLOCH
CORPORATION

900 Lake Havasu Ave. • Lake Havasu City, AZ 86403-2891

222886

© U.S.A. - McCulloch Corporation, 1988 Printed in U.S.A.

Figure 1 GENERAL ASSEMBLY

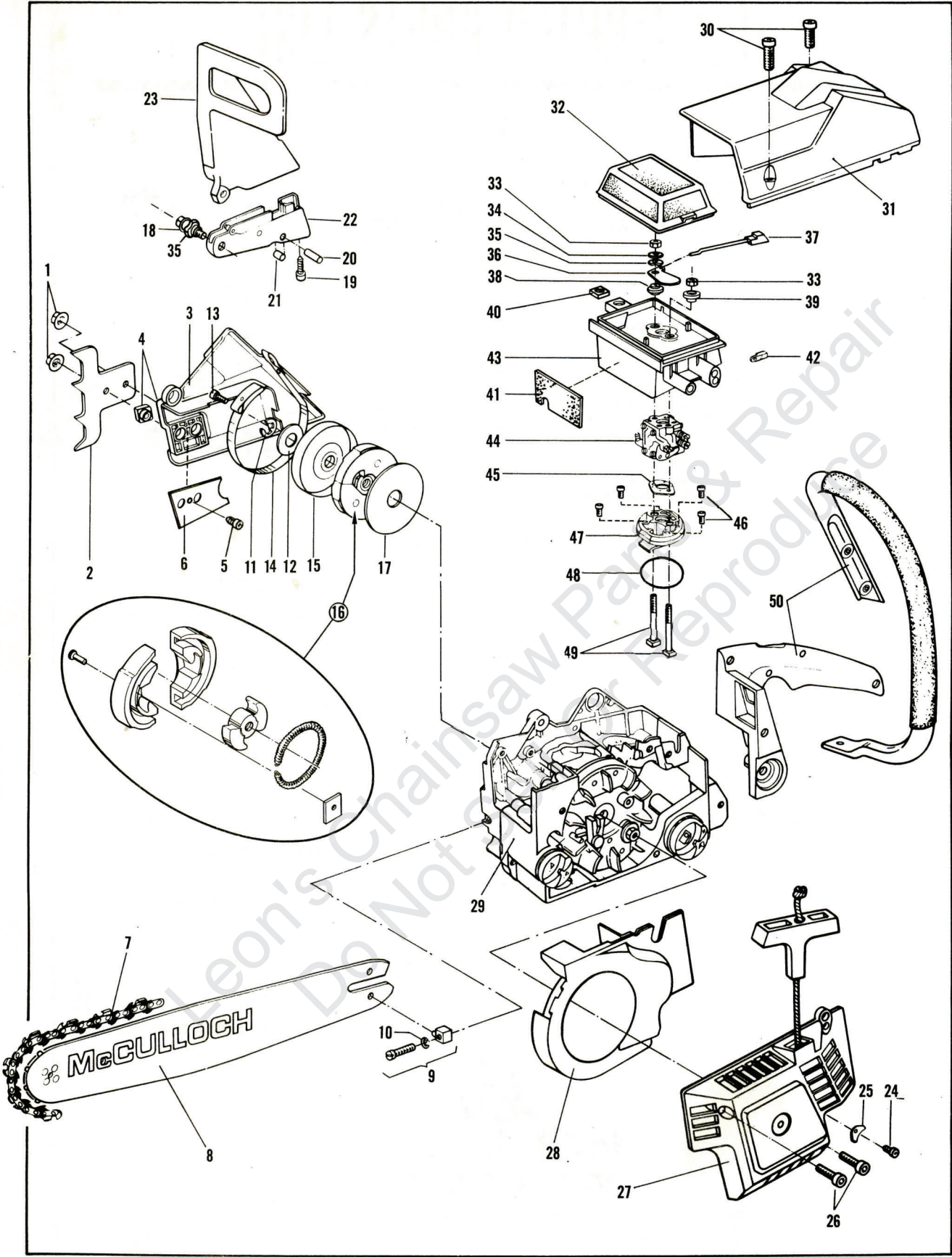

FIGURE 1 GENERAL ASSEMBLY

ITEM NO.	PART NUMBER	DESCRIPTION	UNITS PER ASY.
1	235217	Nut-Spike	2
2	229481	Spike	1
3	229464	Cover-Clutch	1
4	228943	. Insert-Cover	2
5	228554	Screw	1
6	229217	Plate-Bar	1
7	-- --	① Chain	1
8	Fig. 7	Bar	1
9	235574	Bar Adjustment Asy	1
10	235367	. Ring- "E"	1
11	229137	Ring- "E"	1
12	235287	Washer	1
13	235812	Screw	1
14	235073	Band-Brake	1
15	215252	Drum/Bearing Asy	1
16	235115	Clutch	1
17	228853	Shield-Saw Dust	1
18	228955	Screw	1
19	235205	Screw	1
20	235226	Pivot-Brake Band	1
21	235184	Bearing-Roller	1
22	235177	Box-Brake	1
23	229463	Lever-Chain Brake	1
24	228554	Screw	1
25	229018	Plate	1
26	235207	Screw-M5x14	2

ITEM NO.	PART NUMBER	DESCRIPTION	UNITS PER ASY.
27	Fig. 2	Starter Assembly	1
28	229486	Baffle-Fan	1
29	Fig. 5	Powerhead Assembly	1
30	229163	Screw-M5x30	2
31	228722	Cover-Top	1
32	228892	Filter-Air	1
33	235216	Nut	2
34	235163	Washer	1
35	235225	Washer-Wavy	2
36	235020	Plate-Choke	1
37	229152	Knob-Choke	1
38	228910	Bushing-Choke	1
39	228911	Bushing-Choke	1
40	236732	Nut	1
41	229129	Gasket	1
42	235281	Clip	1
43	228655	Airbox	1
44	Fig. 4	Carburetor Assemblies	1
45	235016	Gasket	1
46	228908	Screw-M4x14	4
47	226022	Valve-Reed	1
48	228909	Ring- "O"	1
49	228907	Bolt	2
50	Fig. 3	Handle Assemblies	1

① Refer to Chain, Bar and Accessories Catalog - 180119-R1

STARTER ASSEMBLY **Figure 2**

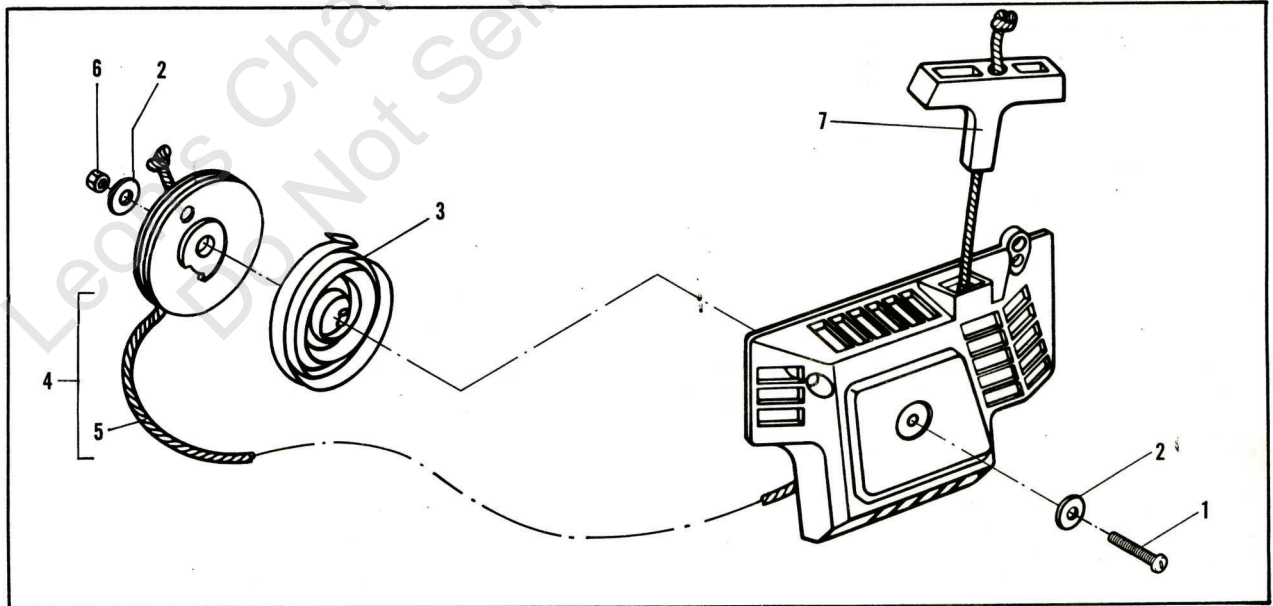

ITEM NO.	PART NUMBER	DESCRIPTION	UNITS PER ASY.
1	229466	Starter Assembly	1
2	229164	. Screw-M4x35	1
3	235048	. Washer	2
4	222784	. Spring-Rewind	1

ITEM NO.	PART NUMBER	DESCRIPTION	UNITS PER ASY.
4	235372	. Drum/Rope Assembly	1
5	83203	.. Rope (31.75"-33.75")	1
6	235431	. Nut	1
7	229469	. Handle-Starter	1

Figure 3

HANDLE ASSEMBLIES

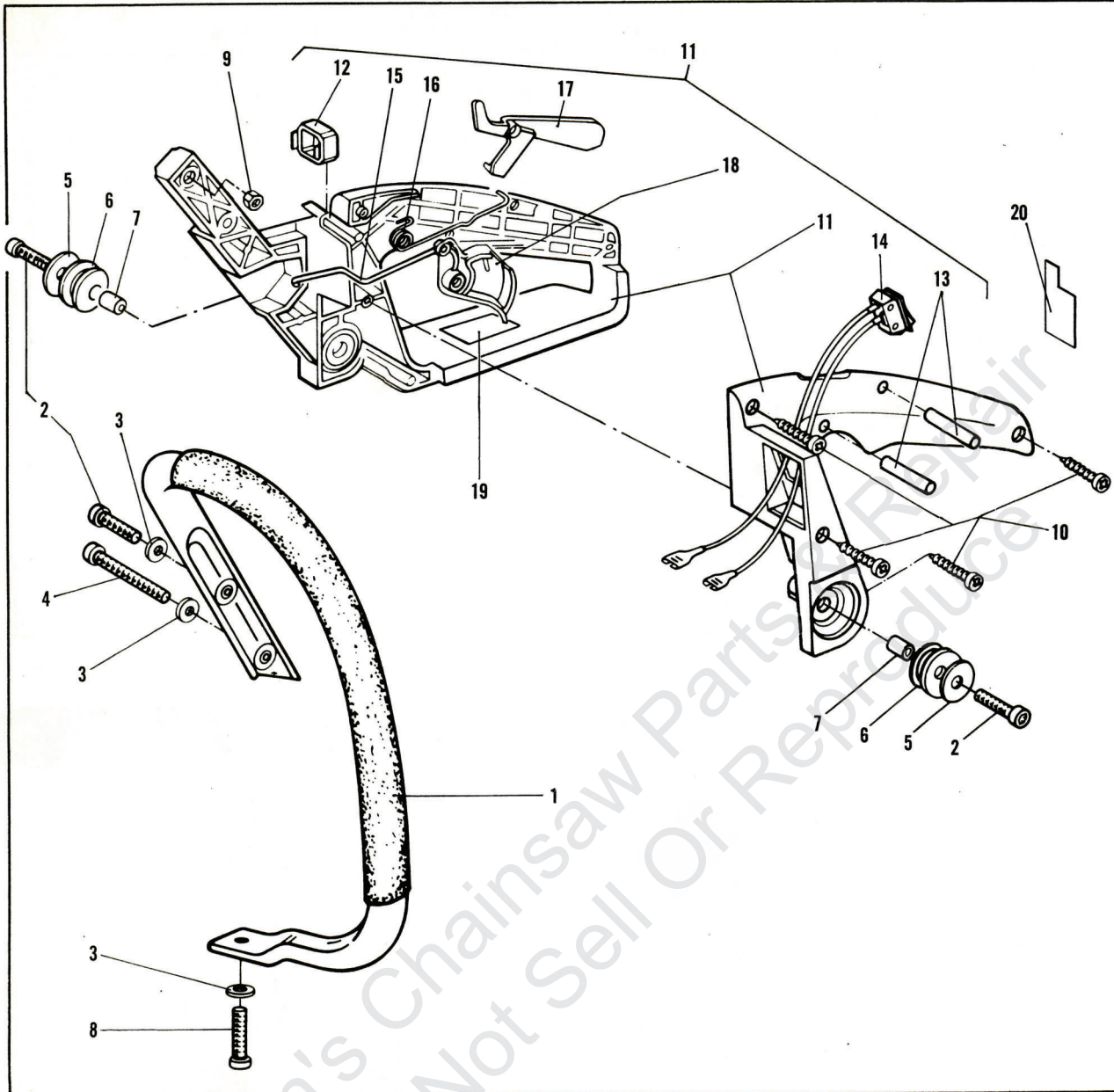

ITEM NO.	PART NUMBER	DESCRIPTION	UNITS PER ASY.
1	228998	Handle-Front	1
2	235210	Screw-M5x25	3
3	235248	Washer	3
4	235244	Screw-M5x45	1
5	235107	Washer	2
6	235105	Mount	2
7	235106	Bushing	2
8	235239	Screw-M5x20	1
9	235216	Nut	1
10	235205	Screw	4

ITEM NO.	PART NUMBER	DESCRIPTION	UNITS PER ASY.
11	229457	Kit-Handle Rear	1
12	229460	. Plug	1
13	229087	. Pin	2
14	228138	. Switch	1
15	229257	. Rod-Throttle	1
16	93771	. Spring	1
17	229462	. Trigger	1
18	229461	. Throttle	1
19	219058	Decal-Safety	1
20	223034	Decal-Warning	1

CARBURETOR ASSEMBLIES

Figure 4

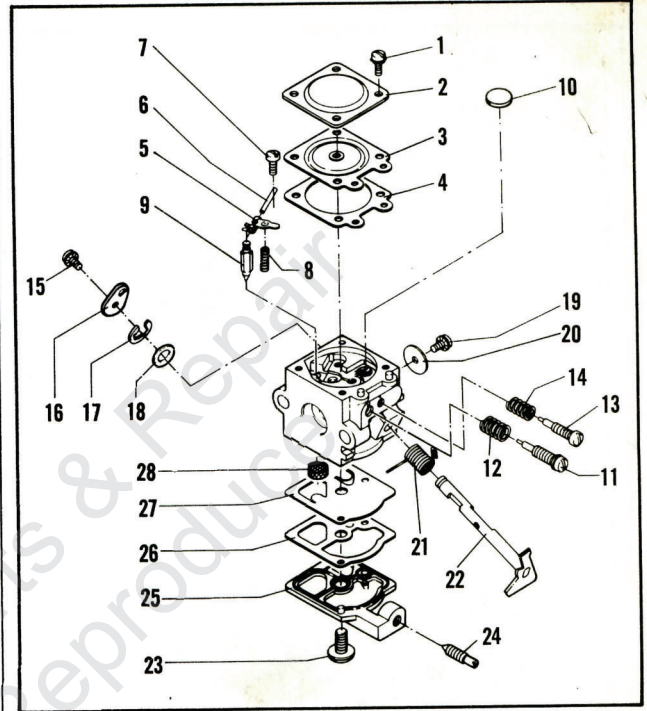
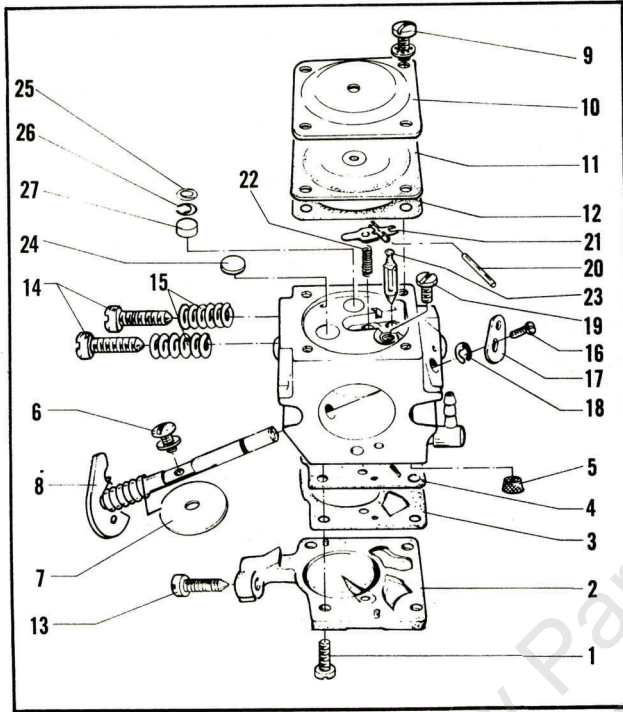

ITEM NO.	PART NUMBER	DESCRIPTION	UNITS PER ASY.
	235270	Carburetor Tillotson HU 57 (Titan 35)	1
	235449	Carburetor Tillotson HU 58 (Titan 40)	1
1	-- --	. Screw	4
2	-- --	. Cover-Fuel Pump	1
3	-- -- ①	. Gasket-Fuel Pump	1
4	-- -- ①	. Diaphragm-Fuel Pump	1
5	-- -- ①	. Screen-Inlet	1
6	-- --	. Screw-Valve	1
7	-- --	. Valve-Throttle	1
8	-- --	. Shaft Asy-Throttle	1
9	-- --	. Screw-Metering Cover	4
10	-- --	. Cover-Metering Diaphragm	1
11	222328 ①	. Diaphragm Asy-Metering	1
12	-- -- ①	. Gasket-Metering Diaphragm	1
13	-- --	. Needle-Idle Speed	1
14	-- --	. Needle-High/Low	2
15	-- --	. Spring-Needle Adjustment	2
16	-- --	. Screw-Lever Throttle	1
17	-- --	. Lever-Throttle	1
18	-- --	. Ring-Retaining	1
19	-- --	. Screw-Pin Lever	1
20	-- --	. Pin	1
21	-- -- ①	. Arm-Needle Valve	1
22	-- --	. Spring-Arm	1
23	-- -- ①	. Valve-Needle	1
24	-- -- ①	. Plug-Welch	1
25	-- --	. Seal	1
26	-- --	. Ring-Retaining	1
27	-- --	. Plug-Welch	1

ITEM NO.	PART NUMBER	DESCRIPTION	UNITS PER ASY.
	228527	Carburetor Assembly Walbro WT 55	1
1	-- -- ①	. Screw-Metering Cover	4
2	-- --	. Cover-Metering Diaphragm	1
3	-- -- ①②	. Diaphragm Asy-Metering	1
4	-- -- ①②	. Gasket-Meter'g Diaphragm	1
5	-- -- ①	. Lever-Metering	1
6	-- -- ①	. Pin-Metering Lever	1
7	-- -- ①	. Screw-Metering Lever Pin	1
8	-- -- ①	. Spring-Metering Lever	1
9	-- -- ①	. Valve-Inlet Needle	1
10	-- -- ①	. Plug-Welch	1
11	-- -- ①	. Needle-High Speed	1
12	-- -- ①	. Spring-Needle High Speed	1
13	-- -- ①	. Needle-Idle	1
14	-- -- ①	. Spring-Needle Idle	1
15	-- --	. Screw-Throttle Lever	1
16	-- --	. Lever-Throttle	1
17	-- --	. Ring-Shaft Retainer	1
18	-- --	. Washer-Throttle Shaft	1
19	-- --	. Screw-Throttle Shutter	1
20	-- --	. Shutter-Throttle	1
21	-- -- ①	. Spring-Throttle Return	1
22	-- --	. Shaft-Assembly Throttle	1
23	-- --	. Screw-Pump Cover	1
24	-- --	. Screw-Idle Adjust	1
25	-- --	. Cover-Fuel Pump	1
26	-- -- ①②	. Gasket-Fuel Pump	1
27	-- -- ①②	. Diaphragm-Fuel Pump	1
28	-- -- ①	. Screen-Fuel Inlet	1

NOTE: Only those parts listed in repair kit are available for service replacement.

① Contained in Repair Kit, P/N 235370

① Contained in Major Repair Kit, 223242
 ② Contained in Gasket/Diaphragm Kit, 223243

Figure 5

POWERHEAD ASSEMBLY

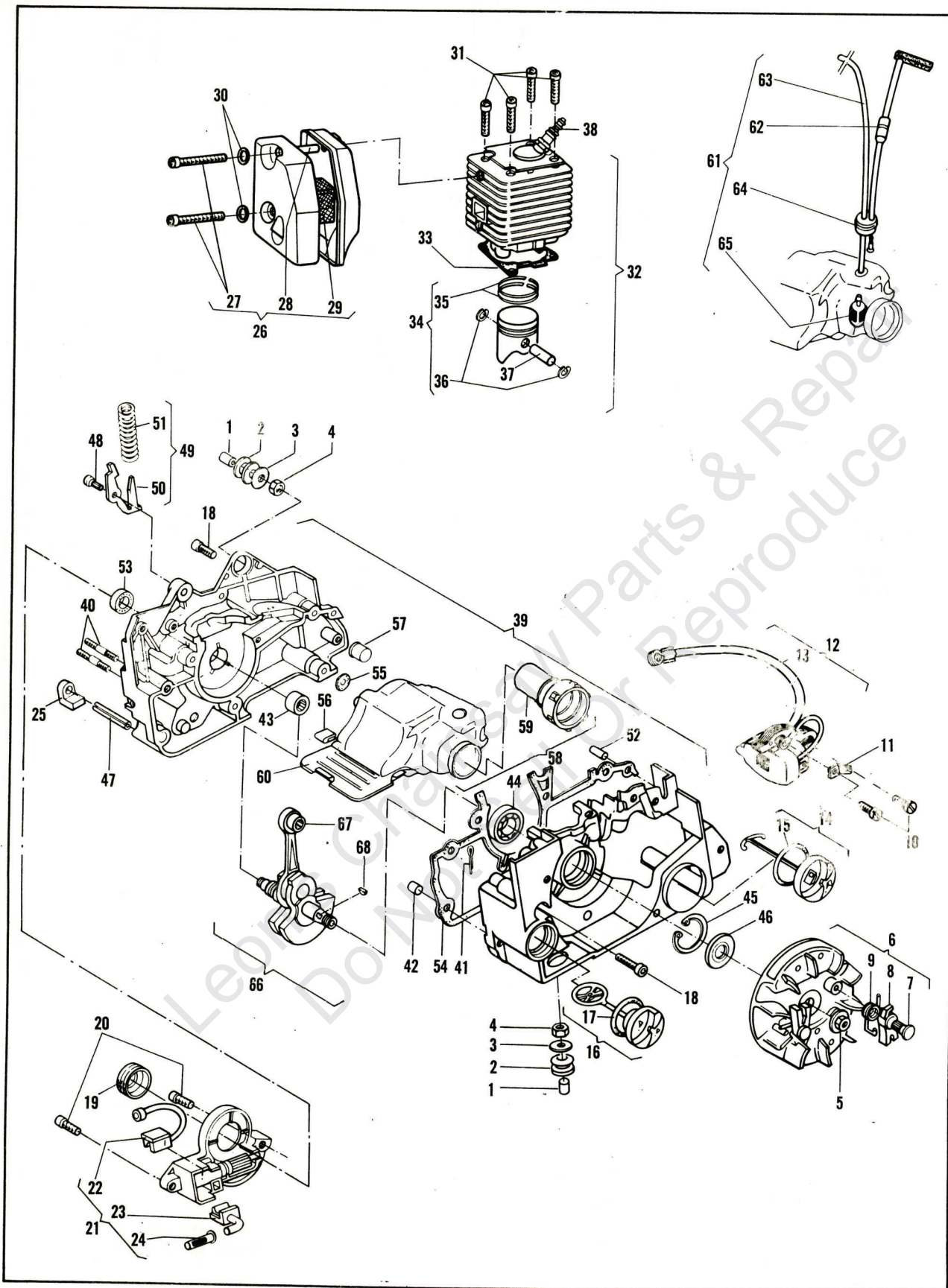

FIGURE 5 POWERHEAD ASSEMBLY

ITEM NO.	PART NUMBER	DESCRIPTION	UNITS PER ASY.
1	235106	Bushing	2
2	235105	Mount	2
3	235107	Washer	2
4	235642	Nut	2
5	235218	Nut-Flywheel	1
6	235138	Kit-Flywheel/Pawl	1
7	235516	. Pin-Pawl	2
8	235517	. Pawl	2
9	235518	. Spring	2
10	235239	Screw-M5x20	2
11	228139	Contact	1
12	228416	Kit-Ignition	1
13	235238	. Wire	1
14	229473	Cap-Fuel Tank	1
15	235510	. Gasket	1
16	229470	Cap-Oil Tank	1
17	235511	. Gasket	1
18	235804	Screw-M5x30	7
19	228597	Worm	1
20	229250	Screw-M5x8	2
21	228598	Oiler Assembly	1
22	228855	. Connector	1
23	228856	. Hose	1
24	228857	.. Filter	1
25	229075	Grommet	1
26	228982	Muffler Assembly	1
27	228975	. Screw-M5x55	2
28	228976	. Spacer	2
29	229072	. Screen-Spark Arrestor	1
30	229237	Washer	2
31	228150	Screw	4
32	235800 ①	Kit-Cylinder	1
33	235135	. Gasket	1
34	235799	. Kit-Piston	1
35	235677	.. Ring-Piston	2
36	235008	.. Ring-Retaining	2
37	-- --	.. Pin-Wrist	1

ITEM NO.	PART NUMBER	DESCRIPTION	UNITS PER ASY.
32	235479 ②	Kit-Cylinder	1
33	235135	. Gasket	1
34	235478	. Kit-Piston	1
35	235178	.. Ring-Piston	2
36	235008	.. Ring-Retaining	2
37	-- --	.. Pin-Wrist	1
38	93018	Plug-Spark	1
39	229482	Kit-Crankcase	1
40	228935	. Bolt-Bar	2
41	228122	. Clip	1
42	235190	. Bushing	1
43	235230	. Bearing	1
44	235900	. Bearing	1
45	235899	. Clip	1
46	228872	. Seal-Oil	1
47	235222	. Catcher-Chain	1
48	235075	. Pivot-Latch	1
49	215758	. Kit-Brake Latch	1
50	216755	.. Latch-Chain Brake	1
51	215721	.. Spring	1
52	235221	. Pin	1
53	235229	. Seal	1
54	228952	Gasket-C'Case	1
55	235700	Gasket-C'Case	1
56	215674	Support	1
57	235672	Support	1
58	235729	Kit-Fuel Tank	1
59	229476	. Tube-Filler	1
60	235670	Shield-Fuel Tank	1
61	235716	Kit-Fuel/Vent	1
62	235741	. Vent	1
63	235713	. Hose-Fuel	1
64	235675	. Grommet	1
65	93720	.. Pickup-Fuel	1
66	228869	Crankshaft Assembly	1
67	235742	. Bearing	1
68	102164	Key-Flywheel	1

① Used on 11600143-06 units only.

② Used on 11600144-04 units only.

Figure 6

ENGINE SPECIFICATIONS

DISPLACEMENT (CC)	Titan 35	2.1 Cu. In. (35cc)
	Titan 40	2.3 Cu. In. (38cc)
BORE & STROKE	Titan 35	1.496 x 1.181
	Titan 40	1.575 x 1.181
CYLINDER BORE	Chrome	
IGNITION	Electronic	
DRY WEIGHT (Power Unit only)	Titan 35	11.0 Lbs.
	Titan 40	11.1 Lbs.
OIL TANK CAPACITY		7.2 Oz.
FUEL TANK CAPACITY		9.7 Oz.
BAR LENGTH	Titan 35	12" - 14" - 16"
	Titan 40	12" - 14" - 16" - 18"
FUEL TYPE	Regular Grade Leaded	
	or Unleaded Gas	
FUEL/OIL MIXTURE	40:1 Using McCulloch Oil	
	20:1 Using Two-Cycle Oil	
CLUTCH ENGAGEMENT SPEED		2800 to 3000 RPM
IDLE SPEED		1800 to 2000 RPM
ROPE-SRARTER	Length	31.75"-33.75" / 80.6mm-85.7mm
	Diameter	.125"-.140" / .32mm-.35mm

Figure 7

BAR

222987	Sprocket Tip 12"
222915	Sprocket Tip 14"
222916	Sprocket Tip 16"
222917	Sprocket Tip 18"

Figure 8

SERVICE TOOLS

236020	Piston Pin Puller
236019	Main Needle Bearing Puller
236024	Intake Pressure Plate
236025	Exhaust Pressure Plate