

ILLUSTRATED PARTS LIST

MODELS	SERIAL NUMBER PREFIX	MODELS	SERIAL NUMBER PREFIX
600439A	11-	600439J	11-
600439B	11-		
600439D	10-, 11-		
600439E	11-		

McC Model Chain Saws are identified by a model number (000000) followed by a suffix letter (A, B, C, etc.) stamped on the identification plate attached to the saw. Suffix letters denote variations in parts or assemblies in the manufacture of the saw.

Part numbers listed in this IPL which have a suffix letter or letters following the description, indicate the part is used only on the model(s) identified by the letter or letters.

Part numbers and descriptions without suffix letter or letters apply to all models of the Super Pro 81E chain saw.

Part numbers which have one or more dots (.) preceding their description may be ordered individually but they are also included in the kit or assembly whose description begins directly above the dot(s).

Part numbers which have changed since the previous printing of the IPL covering these saws, are indicated by a dash (-) preceding the new part number.

The policy of McCulloch Corporation is one of continual improvement in design, manufacturing and engineering advancement wherever possible to assure still finer two-cycle power tools. Hence, specifications, equipment, colors, design and manufacturer's suggested list prices are subject to change without notice and McCulloch Corporation reserves the right to make such changes without prior notification or obligation to backfit or supply backfit components for units previously shipped from the factory.

Super Pro 81E Chain Saw



MAY 1977

- CONTENTS -

	<u>Page</u>
Figure 1. General	2
Figure 2. CHAIN BRAKE & Spike Assys .	4
Figure 3. Fan Housing & Starter Assys .	4
Figure 4. Fuel Tank Assembly	6
Figure 5. Carburetor Assembly	8
Figure 6. Carburetor Assembly	8
Figure 7. Flywheel & Ignition System ..	10
Figure 8. Powerhead & Oiler Assys . . .	12
Figure 9. Muffler Assembly	14
Accessories	15
Service Specifications	15



Super Pro 81E

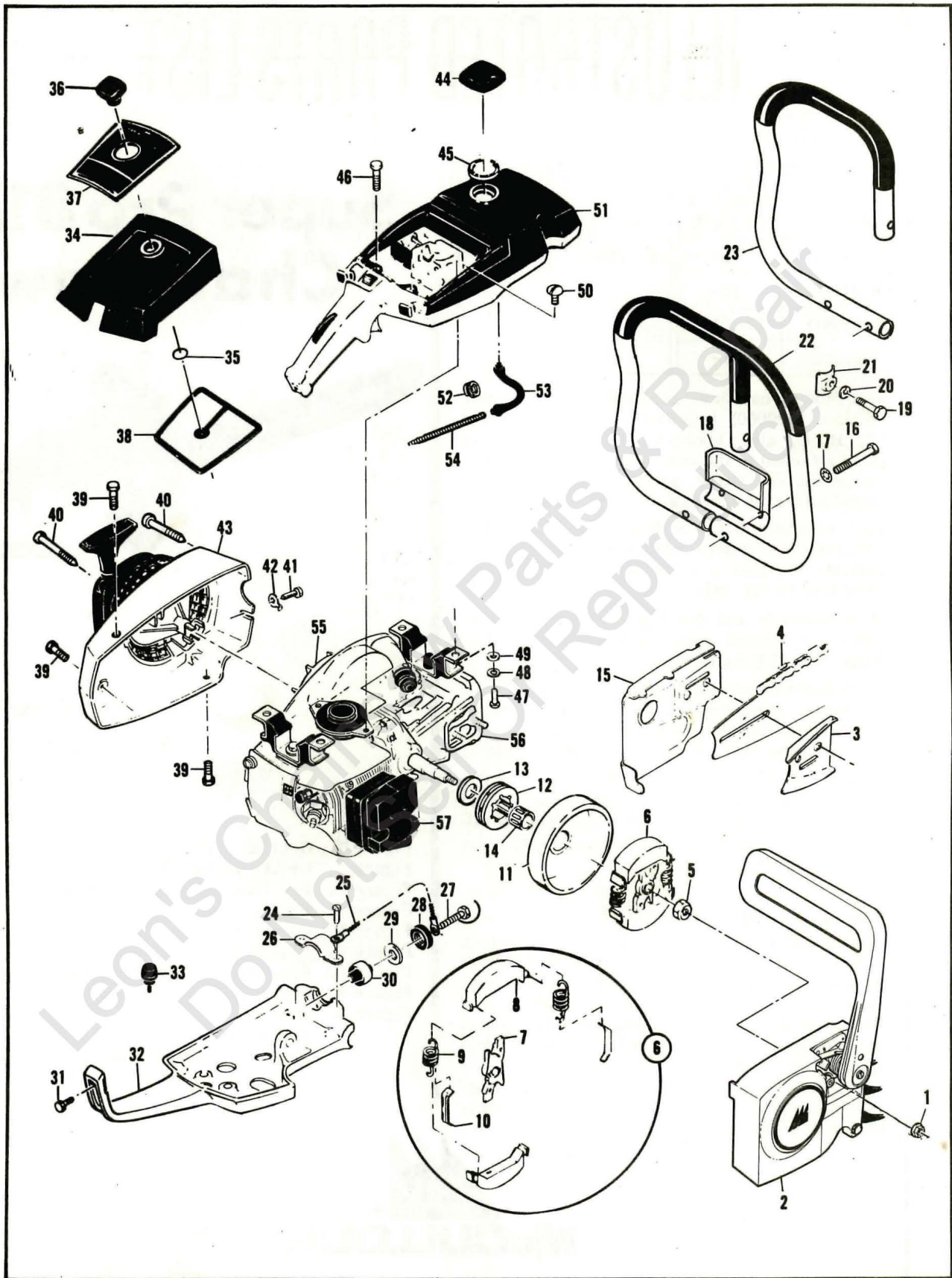

Figure 1. General.

Figure 1. General

Item No.	Part Number	Description	Units Per Asy	Item No.	Part Number	Description	Units Per Asy
1	110961	Nut-Hx 5/16-24	2	31	*105722	Screw - Fil hd 1/4-20 x 1-3/8	1
2		CHAIN BRAKE & Spike * Asys (Figure 2)		32	92816	Brace - Frame	1
3	64325	Plate-Bar protector	1	33	89403	Bumper	2
4		Bar & Chain		34	85850A	Cover Asy - Air cleaner	1
5	86113	Nut-Hx 3/8-24 (L.H.)	1	35	110565	. Ring - Retaining	1
6	87675	Clutch Asy	1	36	68529	. Knob - Cover	1
7	89438	. Rotor-Clutch	1	37	91689A	Nameplate	1
8	67233	. Shoe-Clutch	2	38	85387	Filter - Air	1
9	83223	. Spring-Clutch	2	39	110741	Screw - Pan hd 10-24 x 1/2	3
10	64583	. Retainer-Clutch spring	2	40	87871	Screw - Special	3
11	86942	Kit-Drum & Sprocket 7 T .375P	1	41	102762	Screw - Hx hd 10-24 x 1/2	1
12	86344	. Sprocket	1	42	69890	Lockplate	1
13	86958	. Washer-Sprocket	1	43		Fan Housing & Starter Asy (Figure 3)	
14	110971	Bearing-Sprocket	1	44	89322	Cap Asy - Fuel	1
15	84978	Shield-Sawdust	1	45	69767	. Gasket	1
16	102433	Screw-Hx hd 10-24 x 1-5/8	2	46	110746	Screw - Hx hd 10-24 x 1/2	2
17	101194	Lockwasher - #10	2	47	102861	Screw - Hx hd 1/4-20 x 5/8	2
18	84798	Clamp-Frame	1	48	100153	Lockwasher - 1/4	2
19	102130	Screw-Hx hd 1/4-20 x 1-1/2	1	49	100005	Washer - 1/4	2
20	100153	Lockwasher-1/4	1	50	110807	Screw - Pan hd 8-32 x 5/16	2
21	63484	Clamp-Frame	1	51		Fuel Tank Asy (Figure 4)	
22	91632A	Frame & Grip Asy (A,D,J)	1	52	87826	Clamp - Hose	2
23	91586	Frame & Grip Asy (B,E)	1	53	69598	Line - Pulse	1
24	104950	Screw-Hx hd 10-24 x 5/8	2	54	67944	Spring - Hose	1
25	83828	Wire Asy-Ground	1	55		Flywheel & Ignition System (Figure 8)	
26	83819	Clamp-Lower mount	1	56		Powerhead & Oiler Asys (Figure 9)	
27	110679	Screw-Hx hd 1/4-20 x 2	1	57		Muffler Asy (Figure 10)	
28	84661	Grommet	1				
29	110845	Washer-1/4	1				
30	85898	Mount-Lower	1				

*Also shown as Item 20 in Figure 4.

Super Pro 81E

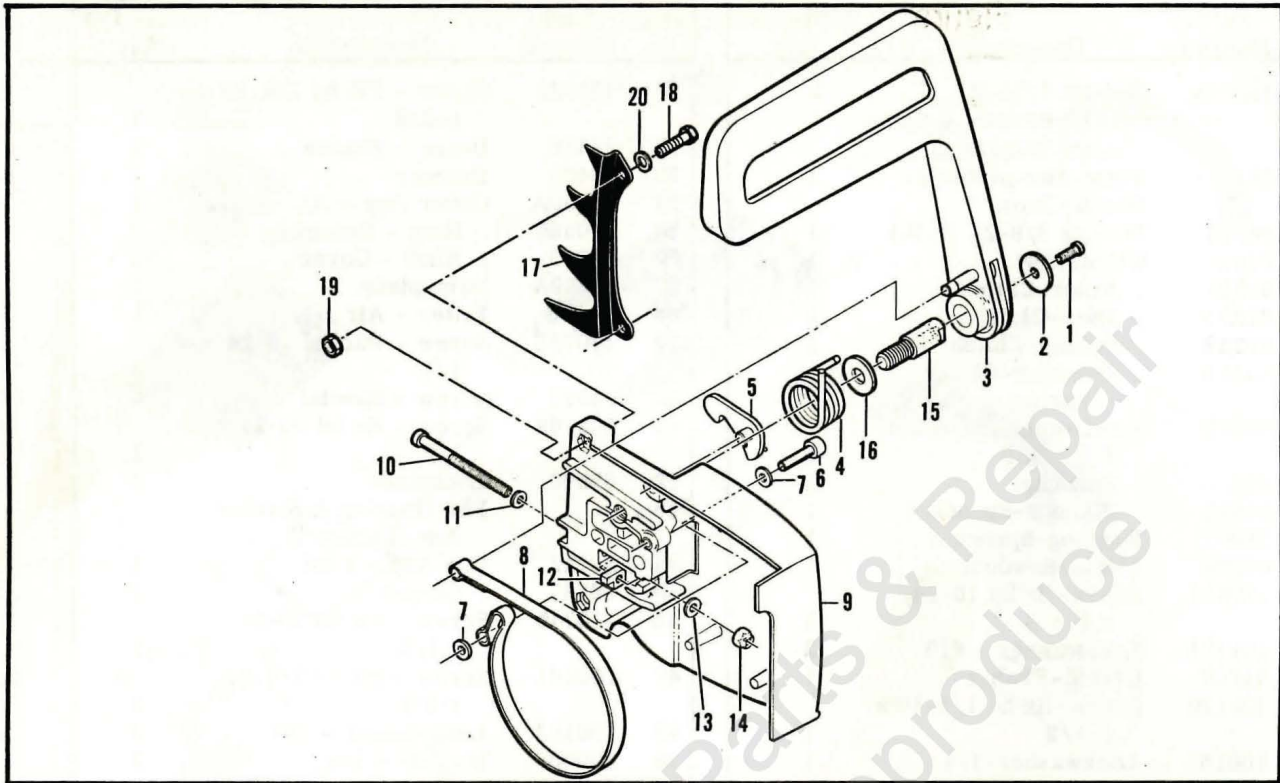

Figure 2. CHAIN BRAKE and Spike Assemblies.

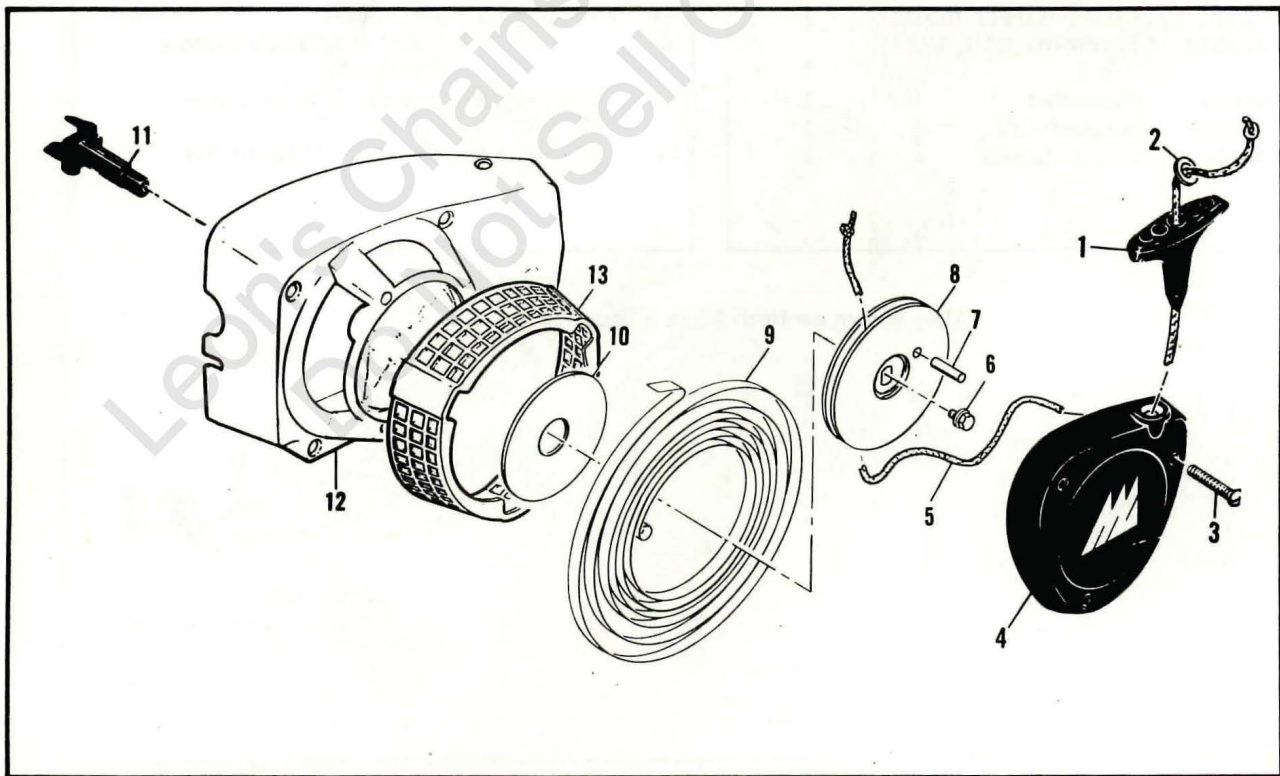

Figure 3. Fan Housing & Starter Assemblies.

Figure 2. CHAIN BRAKE and Spike Assemblies

Item No.	Part Number	Description	Units Per Assy
	91278	CHAIN BRAKE Assy	1
1	102500	. Screw - Pan hd 10-24 x 1/2	1
2	91273	. Washer - Special	1
3	91251A	. Lever Assy	1
4	91239	. Spring	1
5	91235A	. Latch Assy	1
6	105738	. Screw - Skt hd 1/4-20 x 7/8	1
7	91274	. Washer - Special	2
8	91238	. Band	1
9	91249	. Housing Assy	1
10	110527	. . Screw - Fil hd 10-24 x 2-3/4	1

Item No.	Part Number	Description	Units Per Assy
11	110264	. . Washer - #10	1
12	61705	. . Nut - Bar adjusting	1
13	100002	. . Washer - #10	1
14	102067	. . Nut - Hx 10-24	1
15	91246	. . Pin - Lever pivot	1
16	91245	. . Washer - Thrust	1
17	86330	Kit - Spike	1
18	102388	. Screw - Hx hd 10-24 x 5/8	2
19	101191	. Nut - Hx 10-24	2
20	24236	Washer-Special	2

Figure 3. Fan Housing & Starter Assemblies

Item No.	Part Number	Description	Units Per Assy
1	91255	Kit-Starter handle	1
2	105490	. Washer	1
	90921	Fan Housing & Starter Assy	1
3	110646	. Screw-Oval hd 8-32 x 1-1/8	3
4	87672	. Cover Assy-Starter	1
5	87670	. . Rope-Starter	1

Item No.	Part Number	Description	Units Per Assy
6	110341	. Screw-Hex hd 10-24 x 1/2	1
7	105841	. Pin-Roll	1
8	87689	. Drum-Starter	1
9	87680	. Spring-Rewind	1
10	86053	. Shield-Spring	1
11	83748	. Shaft-Starter	1
12	87693	. Kit-Fan housing	1
13	87674	. . Guard-Sawdust	1

Super Pro 81E

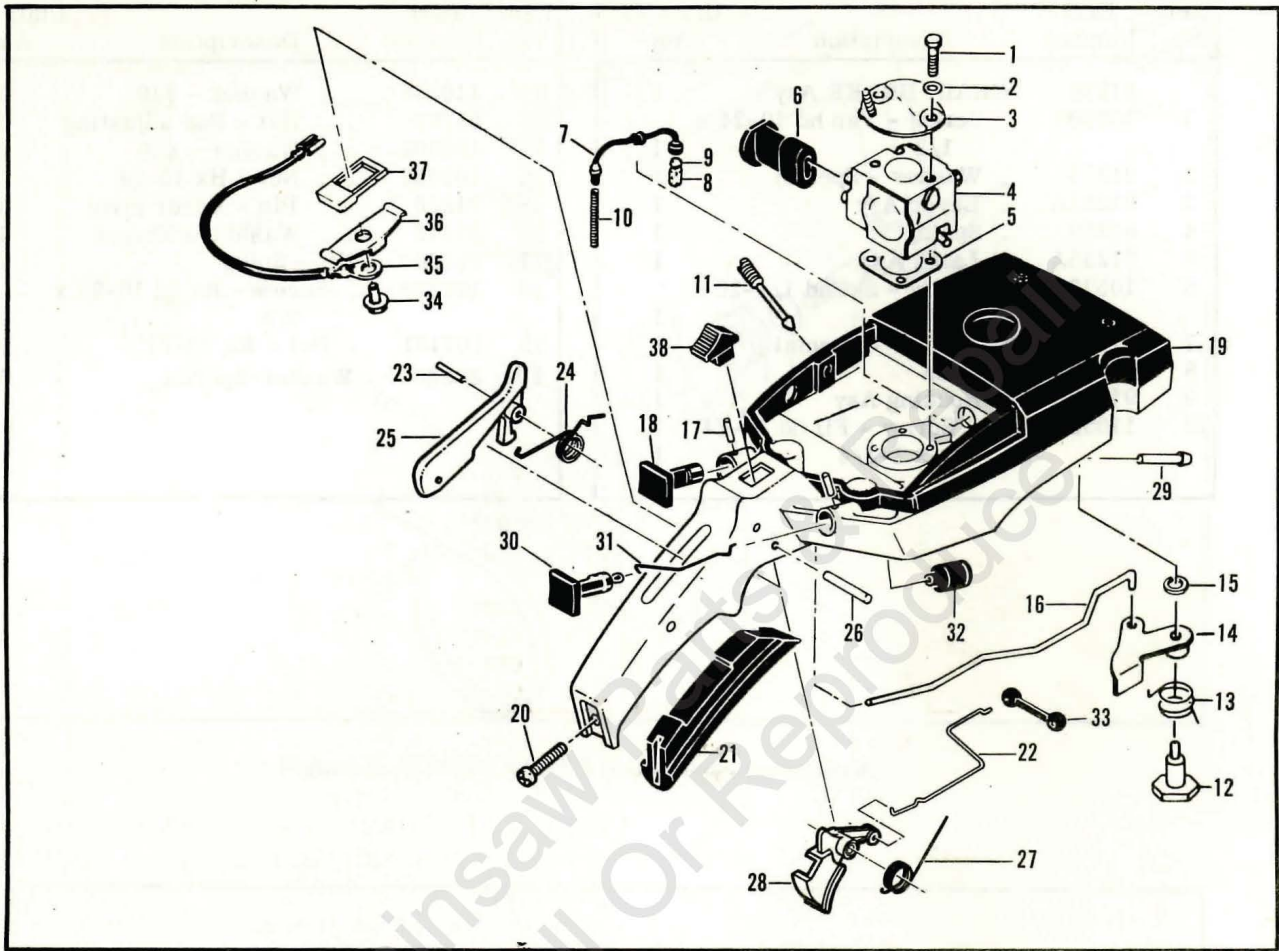

Figure 4. Fuel Tank Assembly.

Figure 4. Fuel Tank Assembly

Item No.	Part Number	Description	Units Per Asy	Item No.	Part Number	Description	Units Per Asy
1	110894	Screw - Hx hd 10-24 x 2-1/8	2	19	87888A	Tank Assembly - Fuel	1
2	110964	Washer	2	20	105722	. Screw - Fil hd 1/4-20 x 1-3/8	1
3	83204	Bracket Assembly	1	21	89400	. Insert - Handle grip	1
4		Carburetor Asy (Fig.5,6)		22	92155	. Rod - Throttle	1
5	86189	Gasket - Carburetor	1	23	105654	. Pin - Roll 1/8 x 7/8	1
6	69629	① Boot - Carburetor controls	1	24	92154	. Spring - Trigger release	1
(6)	85901	② Boot - Carburetor controls	1	25	92153A	. Release - Trigger	1
7	64848	Hose Assembly - Fuel	1	26	110378	. Pin - Roll 3/16x15/16	1
8	63932	. Filter - Fuel	1	27	92152	. Spring - Trigger	1
9	100440	. Washer	1	28	92151A	. Trigger - Throttle	1
10	67944	Spring - Hose	1	29	69600	. Nipple - Pulse line	1
11	86273	Screw - Idle speed	1	30	69630	Button - Choke	1
12	69594	Pivot - Oiler lever	1	31	69631	Rod - Choke	1
13	69781	Spring - Oiler lever	1	32	69597	Boot - Control rod	2
14	69825	Lever Assembly - Oiler	1	33	69043	Snubber - Rod	1
15	105048	Washer - 3/16	1	34	110706	Screw - Fil hd 8-18 x 1/2 (SEMS)	1
16	69802	Rod - Oiler	1	35	92888	Wire Asy - Stop switch	1
17	105673	Pin - Roll 3/32 x 9/16	2	36	62451	Contact - Switch	1
18	63044	Button - Oiler	1	37	62950A	Base - Switch	1
				38	68846	Button - Switch	1

① Used on models with Carburetor Asy, P/N 87821 (Figure 5).

② Used on models with Carburetor Asy, P/N 85916 (Figure 6).

Leon's Chainsaw
Do Not Sell Or

Super Pro 81E

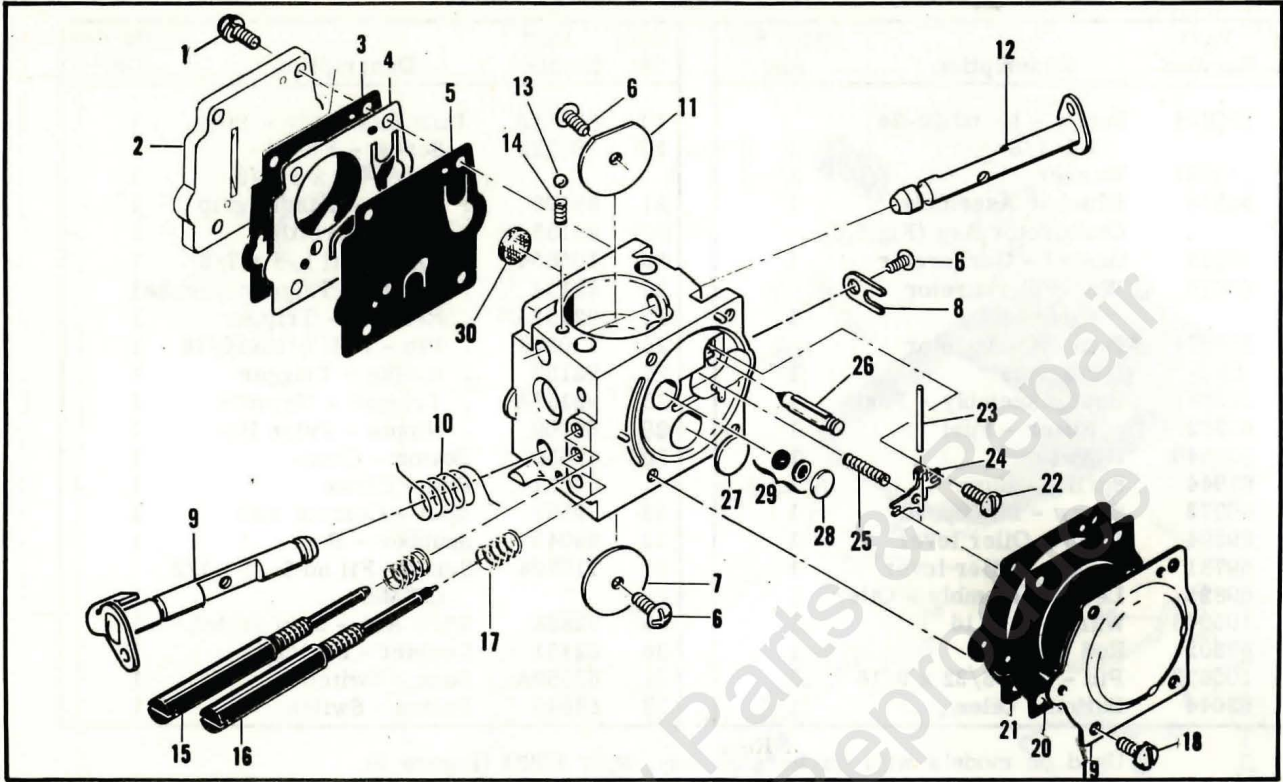

Figure 5. Carburetor.

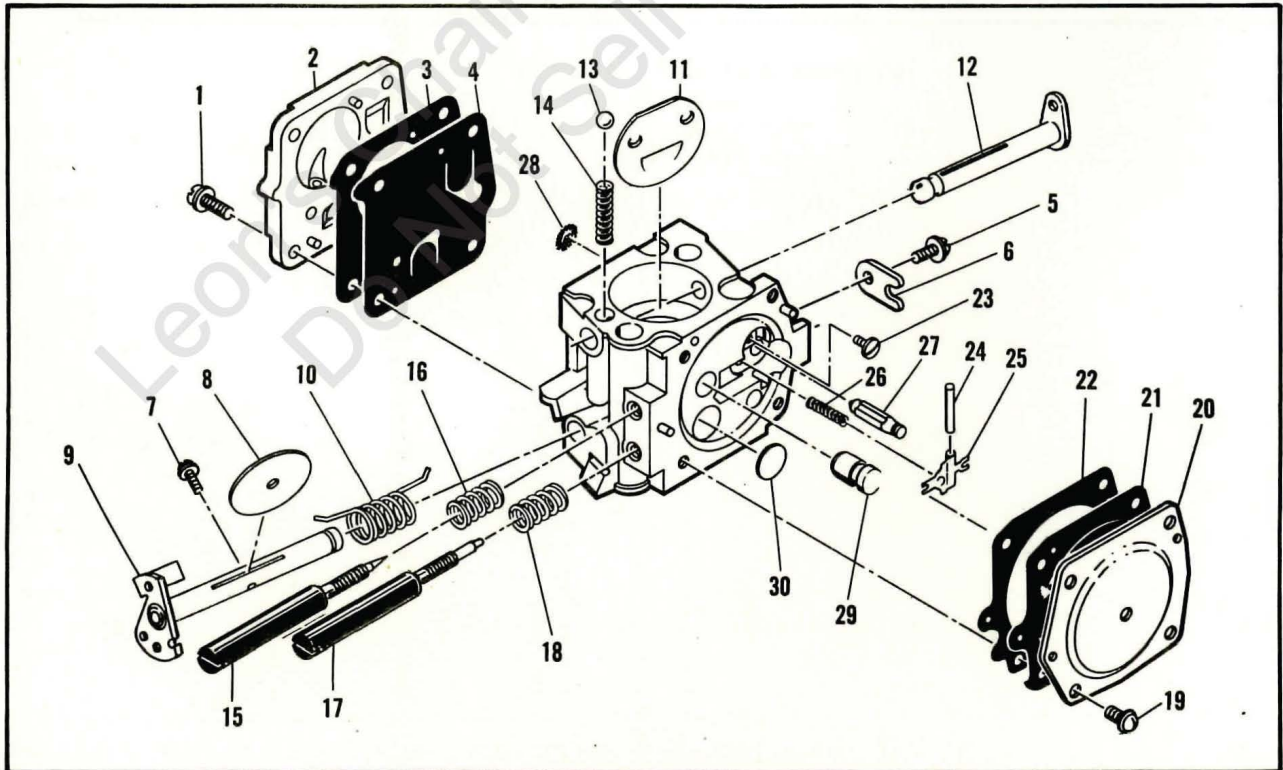

Figure 6. Carburetor.

Figure 5. Carburetor Assembly

Item No.	Part Number	Description	Units Per Asy	Item No.	Part Number	Description	Units Per Asy
	87821	① Carburetor Asy - SDC 38A	1	17	67502	③ . Spring - Needle	2
1	67501	. Screw - Pump cover	4	18	70798	. Screw - Diaphragm	4
2	88731	. Kit - Pump cover	1	19	83761	. Cover - Diaphragm	1
3	88617	② . Gasket - Cover	1	20	67499	③ . Diaphragm - Metering	1
4	67498	③ . Diaphragm - Check valve	1	21	67496	② . Gasket - Diaphragm	1
5	83114	③ . Diaphragm - Fuel pump	1	22	67500	③ . Screw - Lever pin	1
6	47690	③ . Screw - Plate	3	23	67508	③ . Pin - Lever	1
7	83762	. Plate - Throttle	1	24	67509	③ . Lever - Inlet	1
8	67489	. Clip - Shaft	1	25	67503	③ . Spring - Lever	1
9	85980	. Shaft Asy - Throttle	1	26	67491	③ . Valve - Needle	1
10	85981	. Spring - Throttle return	1	27	71690	③ . Plug - 3/8	1
11	67490	. Plate - Choke	1	28	69506	③ . Plug - 5/16	1
12	67488	. Shaft Asy - Choke	1	29	83758	. Kit - Valve & Seat Asy	1
13	100302	③ . Ball - Choke friction	1	30	67507	③ . Screen - Fuel	1
14	67504	③ . Spring - Choke friction	1		67482	③ Gasket Kit	
15	85979	③ . Needle - High Speed	1		85987	Repair Kit	
16	85982	③ . Needle - Idle	1				

① NOTE: This is one of two carburetors used alternately on models with serial number prefix 10-, and 11-.

② Contained in Gasket Kit , P/N 67482.

③ Contained in Repair Kit, P/N 85987.

NOTE: Before ordering parts, identify the carburetor on the saw.

Figure 6. Carburetor Assembly

Item No.	Part Number	Description	Units Per Asy	Item No.	Part Number	Description	Units Per Asy
	85916	① Carburetor Asy - HS 111A	1	16	52936	. Spring - High Speed needle	1
1	52933	. Screw - Pump cover	4	17	86170	. Needle - Idle	1
2	66628	. Cover - Pump	1	18	67133	. Spring - Idle needle	1
3	66629	. Gasket - Cover	1	19	51721	. Screw - Diaphragm cover	4
4	66630	. Diaphragm - Fuel pump	1	20	83724	. Cover - Diaphragm	1
5	48780	. Screw - Clip retainer	1	21	66632	. Diaphragm - Metering	1
6	66646	. Clip - Throttle shaft	1	22	66633	. Gasket - Diaphragm	1
7	48780	. Screw - Plate	1	23	83479	. Screw - Lever pin	1
8	51720	. Plate - Throttle	1	24	66636	. Pin - Lever	1
9	83546	. Shaft Asy - Throttle	1	25	66638	. Lever - Metering	1
10	67136	. Spring - Throttle return	1	26	66404	. Spring - Lever	1
11	65856	. Plate - Choke	1	27	66637	. Valve - Needle	1
12	83725	. Shaft Asy - Choke	1	28	66623	. Screen - Fuel inlet	1
13	100071	. Ball - Choke friction	1	29	83729	. Check Valve - Nozzle	1
14	52930	. Spring - Choke friction	1	30	66622	. Plug - Welch	1
15	86169	. Needle - High speed	1				

① NOTE: This is one of two carburetors used alternately on models with serial number prefix 10-, and 11-.

Super Pro 81E

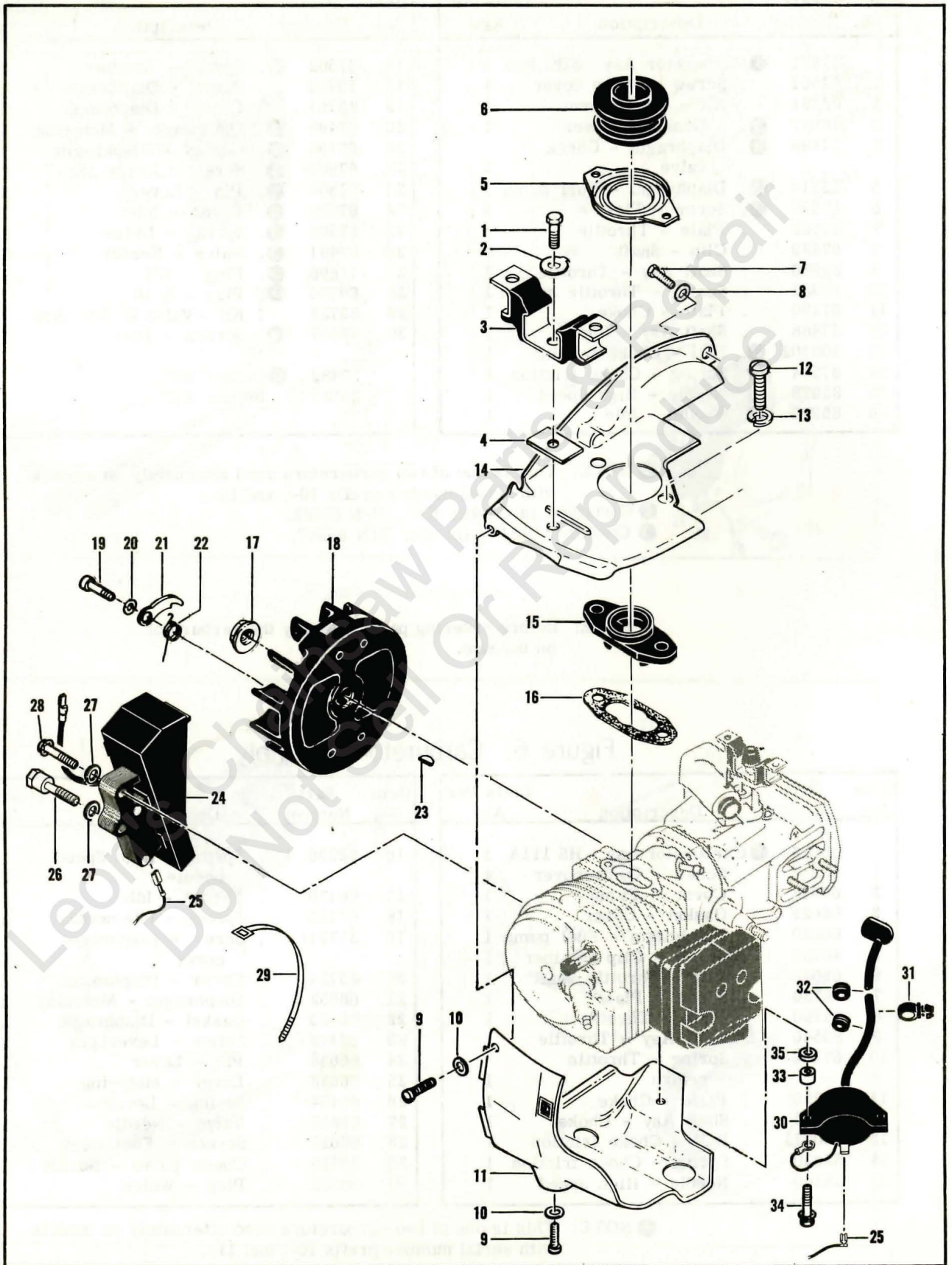

Figure 7. Flywheel & Ignition System

Figure 7. Flywheel & Ignition System

Item No.	Part Number	Description	Units Per Asy
1	83811	Screw-Special	1
2	69924	Lockplate	1
3	91578A	Mount Rear	1
4	84619	Insulator	1
5	86175	Clamp Asy-Boot	1
6	88834A	Beot-Port	1
7	110776	Screw-Fil hd 8-32 x 3/8	1
8	100057	Lockwasher - #8	1
9	102500	Screw-Pan hd 10-24 x 1/2	2
10	100002	Washer-#10	2
11	92815	Shroud-Lower	1
12	104396	Screw-Pan hd 10-24 x 3/4	2
13	101194	Lockwasher-#10	2
14	88835A	Shroud-Upper	1
15	87844	Insulator-Inlet	1
16	88740	Gasket-Insulator	1
17	110703	Nut-Hex 3/8-24	1

Item No.	Part Number	Description	Units Per Asy
18	92886	Flywheel Asy	1
19	88804	Screw-Special	2
20	83241	Washer-Special	2
21	67546	Pawl-Starter	2
22	67545	Spring-Pawl	2
23	100106	Key-Woodruff	1
24	92846	Module Asy-Stator	1
25	92848	Wire Asy-Primary	1
26	92889	Stud-Fan Housing Mounting	1
27	100002	Washer-#10	2
28	103947	Screw-Hx 10-24 x 1.0	1
29	93273	Tie Cable	1
30	92847	Transformer Asy	1
31	110973	Clip-Guide .375	1
32	100268	Grommet	2
33	92890	Spacer-Transformer	2
34	110749	Screw-Hx W 10-24 x 1.12	2
35	100002	Washer-#10	2

Leon's Chainsaw Parts & Repair
Do Not Sell Or Reproduce

Super Pro 81E

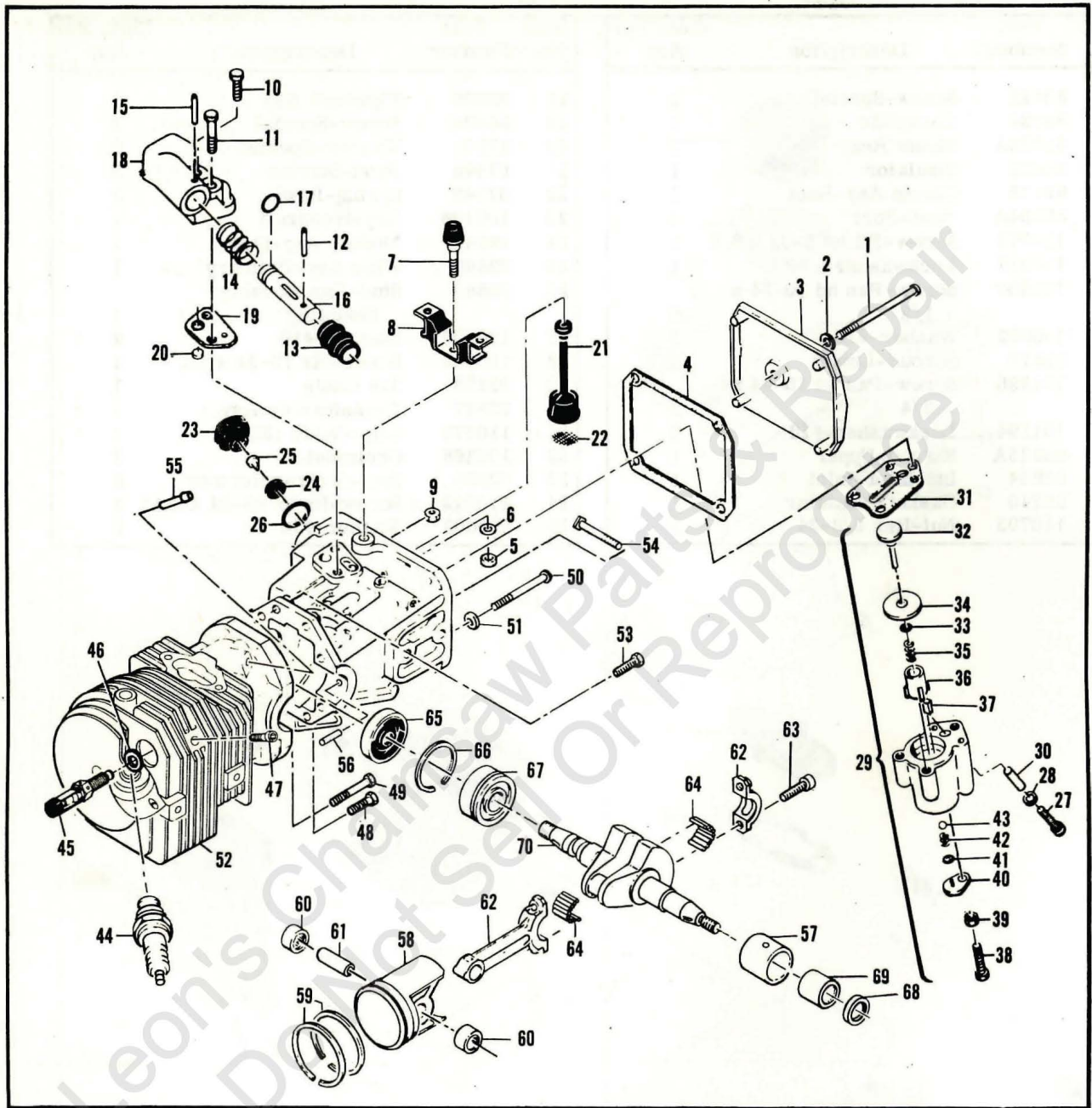

Figure 8. Powerhead & Oiler Assemblies.

Figure 8. Powerhead & Oiler Assemblies

Item No.	Part Number	Description	Units Per Asy	Item No.	Part Number	Description	Units Per Asy
1	110291	Screw - Pan hd 10-24 x 2-5/8	1	39	100251	. Nut-Hx 8-32	1
2	110921	Washer - Sealing	1	40	62407	. Cover-Outlet valve	1
3	86304	Cover - Oil tank	1	41	106104	. "O" Ring	1
4	86306	Gasket - Cover	1	42	92844	. Spring-Outlet valve	1
5	101143	Nut - Hx 1/4-20	1	43	102809	. Ball-Outlet valve	1
6	102523	Washer - 1/4	1	44	63432	Spark Plug (A,B,D,J)	1
7	69832	Bumper - Front	1		93017	Spark Plug (E)	1
8	91582	Mount - Front	1	45	87866	Valve-Dsp	1
9	100955	Nut - Hx 8-32	1	46	85505	Washer-Valve	1
10	110670	Screw - Fil hd 8-32 x 1/2	1	47	110681	Screw-Skt hd 10-24 x 1/4	1
11	105245	Screw - Fil hd 8-32 x 1 (SEMS)	1	48	110963	Screw-Hx hd 8-32 x 1.0 W	1
12	105673	Pin - Roll 3/32 x 9/16	1	49	110644	Screw-Hx hd 8-32 x 1-1/2	1
13	69586	Boot - Plunger	1	50	62105	Screw Asy-Sealing	4
14	69585	Spring - Plunger	1	51	62842	. Washer-Sealing	4
15	101556	Pin - Roll 1/8 x 5/8	1	52	93265	① Kit-Cyl., C'case, Piston	1
16	91219	Plunger - Pump	1	53	110288	. Screw-Hx hd 8-32 x 3/4	2
17	105614	"O" Ring	1	54	62065	. Bolt-Bar mounting	2
18	91218	Body - Oil pump	1	55	69600	. Nipple-Pulse line	1
19	91669	Gasket - Oil pump	1	56	110851	. Pin-Dowel	1
20	91668	Valve - Oiler	1	57*	87152	. Insert-Bearing	1
21	91672	Hose - Oil	1	58	92518	① . Piston Asy (Identified A)	1
22	51506	. Screen - Hose	1		92519	① . Piston Asy (Identified B)	1
23	87270	Cap - Oil tank	1		92520	. Piston Asy (Identified C)	1
24	87269	. Retainer - Valve	1	59	87854	. . Ring Set-Piston	1
25	86402	. Valve	1	60	110590	. . Bearing-Needle	2
26	101148	"O" Ring	1	61	69020	Pin-Piston	1
27	110865	Screw - Skt hd 10-24 x 7/8	1	62	85237	Connecting Rod Asy	1
28	100003	Washer - #10	1	63	61627A	. Screw-Special	2
29	89115A	Pump Asy - Pulse	1	64	85246	. Roller-(set of 22)	1
30	91774	. Sleeve	1	65	61618	Seal-Oil	1
31	92818	. Seal - Pulse pump	1	66	63464	Ring-Snap	1
32	60260A	. Piston Asy - Pump	1	67	63429B	Bearing-Ball	1
33	105603	. "O" Ring	1	68*	110260	Seal-Oil	1
34	86182	. Ring - Piston	1	69*	104357	Bearing-Needle	1
35	60259	. Spring - Piston	1	70	92885	Crankshaft	1
36	62227	. Sleeve - Adjustment	1				
37	91259	. Pad - Oil pump	1				
38	110386	. Screw - Hx hd 8-32 x 1	1				

*These three items are contained in Needle Insert/Bearing Asy, P/N 87151.

- ① Cylinder/Crankcase and Piston Assembly Kits are furnished in matched sets and are identified by a matching letter marking "A", "B" or "C" on both cylinder and piston. Order replacement pistons identified with the letter identification on the cylinder. For piston replacement in an unmarked cylinder, use Piston Assembly, P/N 92519, identified "B".

Super Pro 81E

Figure 9. Muffler Assembly

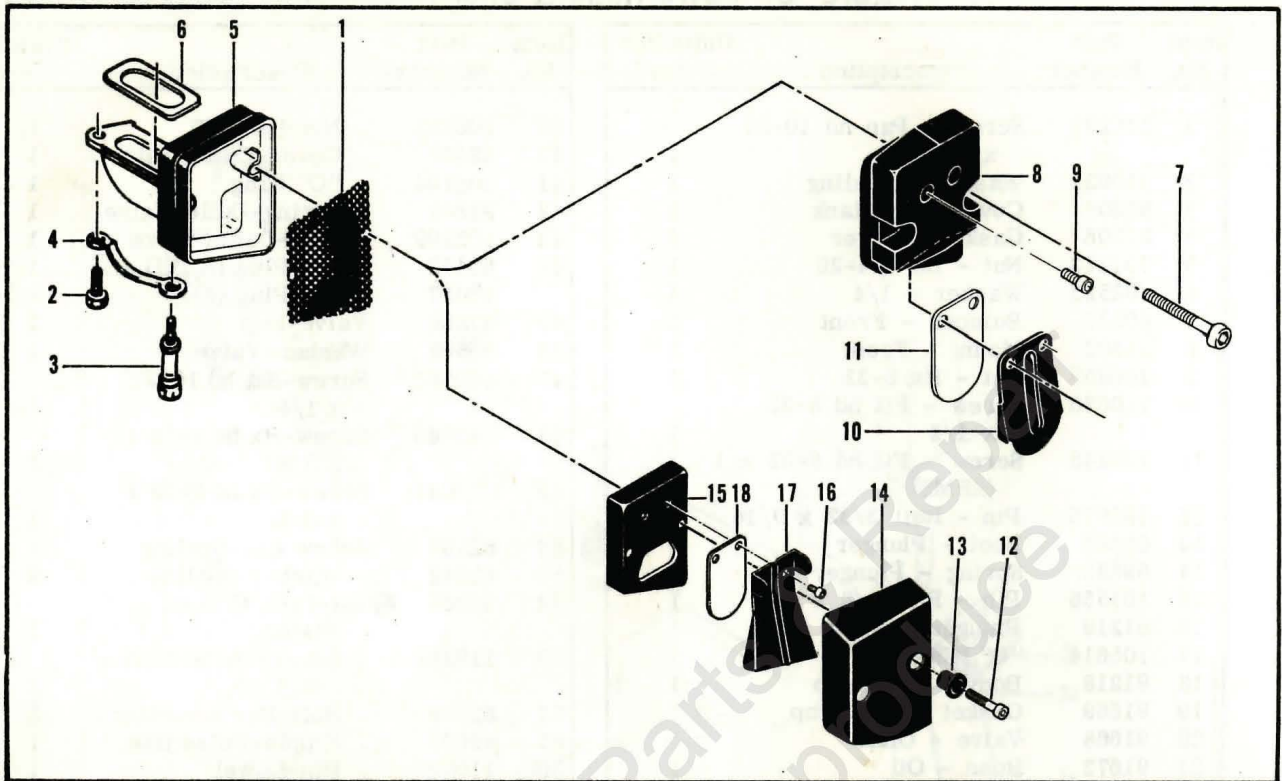

Item No.	Part Number	Description	Units Per Asy.
1	84580	Baffle-Muffler	1
2	110529	Screw-Hx hd 10-24 x 1/2	1
3	84578	Screw-Special	1
4	84579	Plate-Lock	1
5	84572	Body & Duct Asy	1
6	84577	Gasket-Muffler	1
7	110440	Screw-Skt hd 10-24 x 1-3/4 (B,D,E,J)	2
8	84581A	Kit-Cover & Valve Asy (B,D,E,J)	1
9	110472	Screw-Skt hd 8-32 x 5/16 (B,D,E,J)	2

Item No.	Part Number	Description	Units Per Asy.
10	87193	. Stop-Reed (B,D,E,J)	1
11	85585	. Valve-Reed (B,D,E,J)	1
12	110440	Screw-Skt hd 10-24 x 1-3/4 (A)	2
13	92539	Bushing-Spacer (A)	2
14	92538	Cover-Cooling (A)	1
15	92551	Cover/Valve Asy (A)	1
16	110472	Screw-Skt hd 8-32 x 5/16 (A)	2
17	92552	. Stop-Reed (A)	1
18	85585	. Valve-Reed (A)	1

Accessories

Part Number	Description
86218	Kit-Preheater
86209	Kit-Duct, Valve, Guard
84597	Baffle-Spark arrester
86943	Kit-Sprocket & Drum 8T .375P
86344	Kit-Sprocket & Drum 7T .404P
92455	Rope-Starter (100 ft)

Part Number	Description
85968	Guard-Hand
87839	Adapter-Bar mounting
91226	Wrench-Clutch retaining
63432	Spark Plug (standard)
63097	Spark Plug (hotter)
63746	Scrench

Service Specifications

Spark Plug Gap	.025 inch (.63 mm)
Lamination Gap	.011 to .015 inch (.28 to .38 mm)
Timing	26° BTDC
Clutch Engagement Speed	2800 to 3000 rpm
Torques	Connecting Rod Screws: 65 to 70 pound x inches (7.3 to 7.9 N.m.)
	Clutch Nut: 160 to 170 pound x inches (18.1 to 19.2 N.m.)
	Flywheel Nut: 265 to 325 pound x inches (29.9 to 36.7 N.m.)