

ILLUSTRATED PARTS LIST

MODELS	SERIAL NUMBER PREFIX	MODELS	SERIAL NUMBER PREFIX
600438A	11-, 12-, 14-, 15-	600438D	11-, 12-, 14-, 15-
600438B	11-, 12-, 14-, 15-	600438E	14-, 15-

Super Pro 81 chain saws are identified by a model number (600438) followed by a suffix letter (A, B, D or E) stamped on the identification plate attached to the saw. Suffix letters denote variations in parts or assemblies in the manufacture of the saw.

Part numbers listed in this IPL which have a suffix letter or letters following the description, indicate the part is used only on the model(s) identified by the letter or letters.

Part numbers and descriptions without suffix letter or letters apply to all models of the Super Pro 81 chain saw.

Part numbers which have one or more dots (.) preceding their description may be ordered individually but they are also included in the kit or assembly whose description begins directly above the dot(s).

Part numbers which have changed since the previous printing of the IPL covering these saws, are indicated by a dash (-) preceding the new part number.

The policy of McCulloch Corporation is one of continual improvement in design, manufacturing and engineering advancement wherever possible to assure still finer two-cycle power tools. Hence, specifications, equipment, colors, design and manufacturer's suggested list prices are subject to change without notice and McCulloch Corporation reserves the right to make such changes without prior notification or obligation to backfit or supply backfit components for units previously shipped from the factory.

SUPER PRO 81 Chain Saw

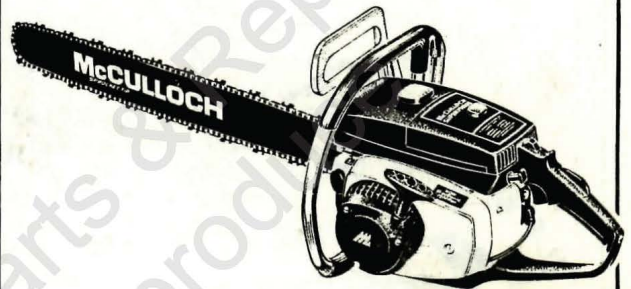

JULY 1976

- CONTENTS -

	<u>Page</u>
Figure 1. General	2
Figure 2. CHAIN BRAKE & Spike Assys .	4
Figure 3. Fan Housing & Starter Assys .	4
Figure 4. Fuel Tank Assembly	6
Figure 5. Carburetor Assembly	6
Figure 6. Carburetor Assembly	8
Figure 7. Carburetor Assembly	8
Figure 8. Flywheel & Ignition System ..	10
Figure 9. Powerhead & Oiler Assys . . .	12
Figure 10. Muffler Assembly	14
Accessories	15
Service Specifications	15



SUPER PRO 81

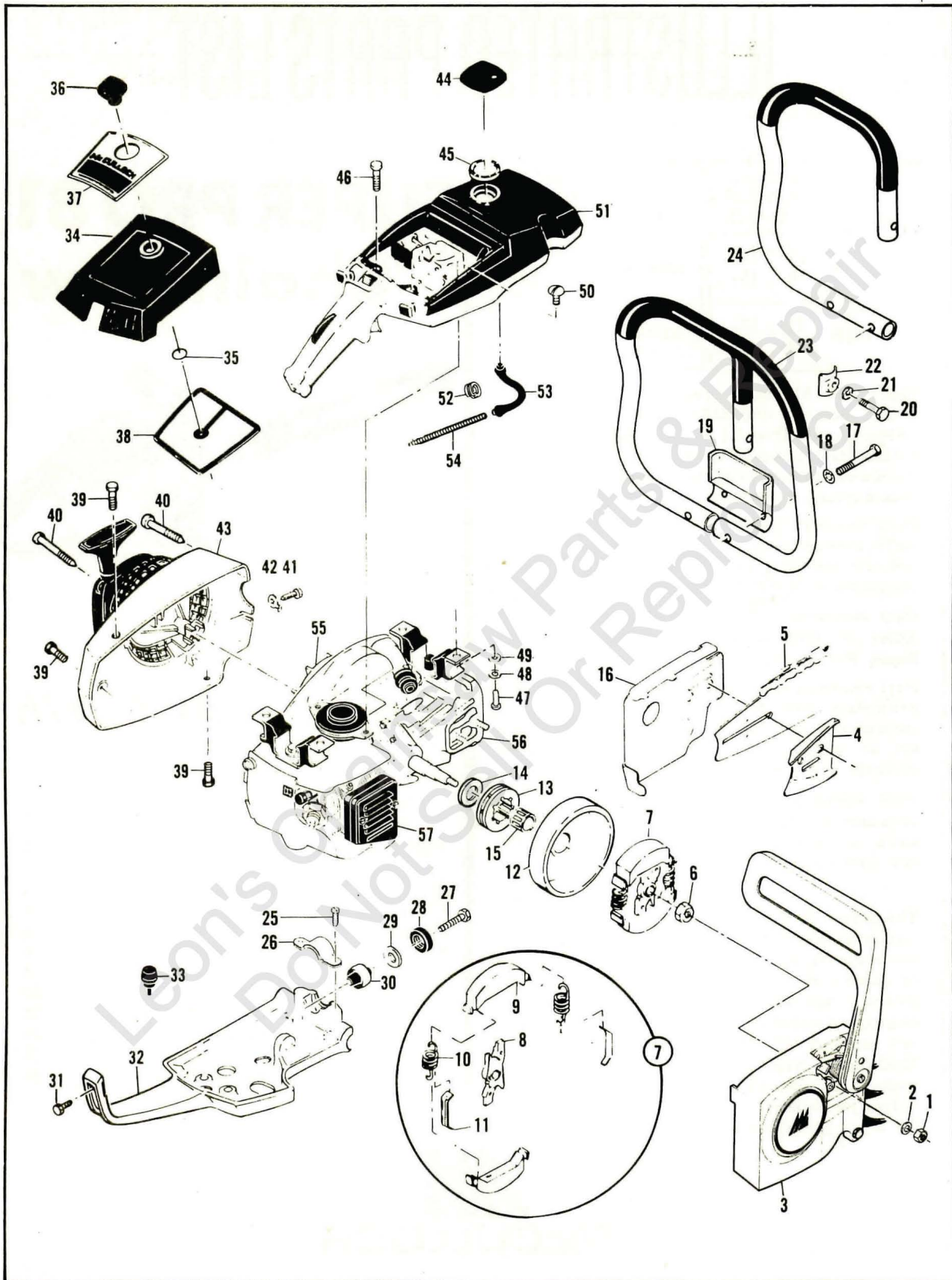

Figure 1. General.

Figure 1. General

Item No.	Part Number	Description	Units Per Asy
1	-110961	Nut - Hx 5/16-24	2
2	100440	① Washer - 5/16	2
3		CHAIN BRAKE & Spike Asys (Figure 2)	
4	64325	Plate - Bar protector	1
5		Bar & Chain	
6	86113	Nut - Hx 3/8-24 (L.H.)	1
7	87675	Clutch Asy	1
8	89438	. Rotor - Clutch	1
9	67233	. Shoe - Clutch	2
10	83223	. Spring - Clutch	2
11	64583	. Retainer - Clutch spring	2
12	86942	Kit - Drum & Sprocket 7 T .375P	1
13	86344	. Sprocket	1
14	86958	. Washer - Sprocket	1
15	110330	Bearing - Sprocket	1
16	84978	Shield - Sawdust	1
17	102433	Screw - Hx hd 10-24 x 1-5/8	2
18	101194	Lockwasher - #10	2
19	84798	Clamp - Frame	1
20	102130	Screw - Hx hd 1/4-20 x 1-1/2	1
21	100153	Lockwasher - 1/4	1
22	63484	Clamp - Frame	1
23	-91632A	Frame & Grip Asy (D)	1
24	-91586	Frame & Grip Asy (A, B, E)	1
25	104950	Screw - Hx hd 10-24 x 5/8	2
26	83819	Clamp - Lower mount	1
27	110679	Screw - Hx hd 1/4-20 x 2	1
28	84661	Grommet	1
29	110845	Washer - 1/4	1
30	85898	Mount - Lower	1

Item No.	Part Number	Description	Units Per Asy
31	105722	② Screw - Fil hd 1/4-20 x 1-3/8	1
32	-90986	Brace - Frame	1
33	89403	Bumper	2
34	85850A	Cover Asy - Air cleaner	1
35	110565	. Ring - Retaining	1
36	68529	. Knob - Cover	1
37	91515	Nameplate	1
38	85387	Filter - Air	1
39	110741	Screw - Pan hd 10-24 x 1/2	3
40	87871	Screw - Special	3
41	102762	Screw - Hx hd 10-24 x 1/2	1
42	69890	Lockplate	1
43		Fan Housing & Starter Asy (Figure 3)	
44	89322	Cap Asy - Fuel	1
45	69767	. Gasket	1
46	-110746	Screw - Hx hd 10-24 x 1/2	2
47	102861	Screw - Hx hd 1/4-20 x 5/8	2
48	100153	Lockwasher - 1/4	2
49	100005	Washer - 1/4	2
50	110807	Screw - Pan hd 8-32 x 5/16	2
51		Fuel Tank Asy (Figure 4)	
52	87826	Clamp - Hose	2
53	69598	Line - Pulse	1
54	67944	Spring - Hose	1
55		Flywheel & Ignition System (Figure 8)	
56		Powerhead & Oiler Asys (Figure 9)	
57		Muffler Asy (Figure 10)	

① Used on models with serial number prefix 11-, 12-, 14-.

② Also shown as Item 20 in Figure 4.

SUPER PRO 81

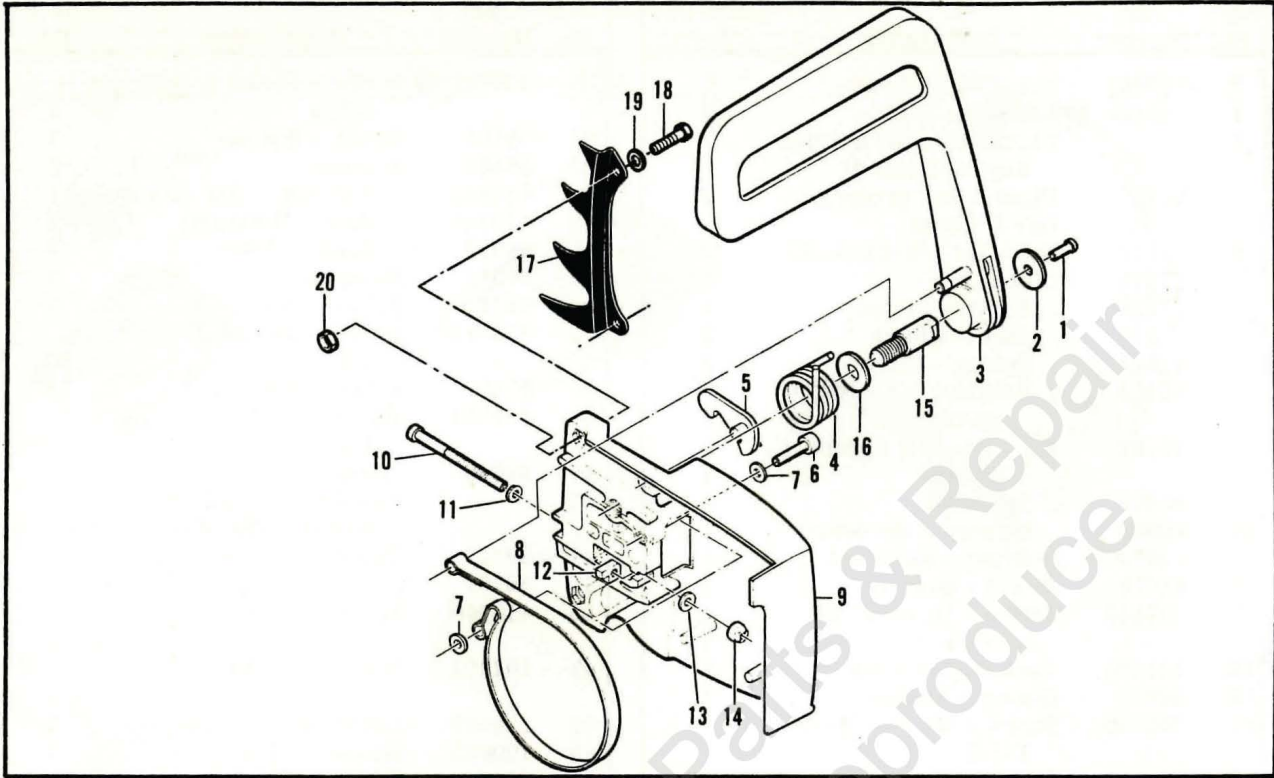

Figure 2. CHAIN BRAKE and Spike Assemblies.

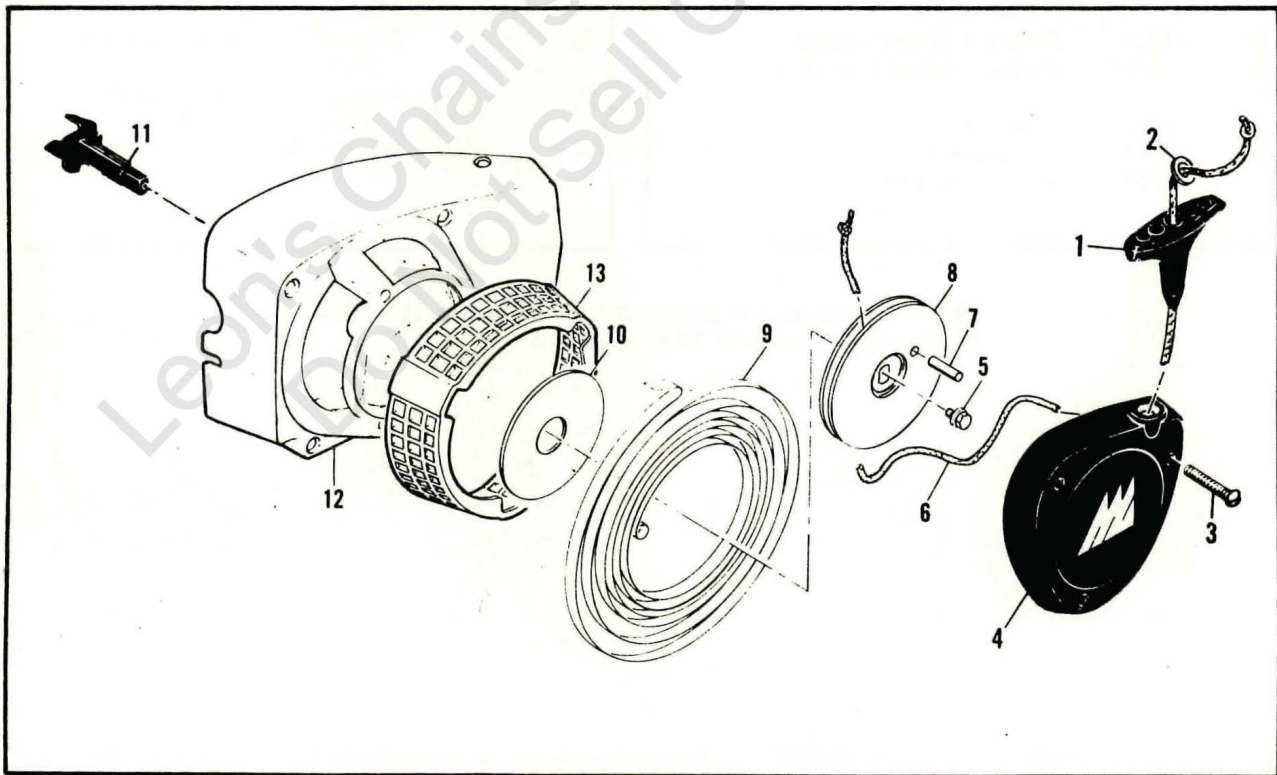

Figure 3. Fan Housing & Starter Assemblies.

Figure 2. CHAIN BRAKE and Spike Assemblies

Item No.	Part Number	Description	Units Per Assy
	91278	CHAIN BRAKE Assy	1
1	102500	. Screw - Pan hd 10-24 x 1/2	1
2	91273	. Washer - Special	1
3	91251	. Lever Assy	1
4	91239	. Spring	1
5	91235A	. Latch Assy	1
6	105738	. Screw - Skt hd 1/4-20 x 7/8	1
7	91274	. Washer - Special	2
8	91238	. Band	1
9	91249	. Housing Assy	1
10	110527	. . Screw - Fil hd 10-24 x 2-3/4	1

Item No.	Part Number	Description	Units Per Assy
11	110264	. . Washer - #10	1
12	61705	. . Nut - Bar adjusting	1
13	100002	. . Washer - #10	1
14	102067	. . Nut - Hx 10-24	1
15	91246	. . Pin - Lever pivot	1
16	91245	. . Washer - Thrust	1
17	86330	Kit - Spike	1
18	102388	. Screw - Hx hd 10-24 x 5/8	2
19	24236	. Washer - Special	2
20	101191	. Nut - Hx 10-24	2

Figure 3. Fan Housing & Starter Assemblies

Item No.	Part Number	Description	Units Per Assy
1	91255	Kit - Starter handle	1
2	105490	. Washer	1
	-90921	Fan Housing & Starter Assy	1
3	110646	. Screw - Oval hd 8-32 x 1-1/8	3
4	87672	. Cover Assy - Starter	1
5	110341	. Screw - Hex hd 10-24 x 1/2	1

Item No.	Part Number	Description	Units Per Assy
6	87670	. Rope - Starter	1
7	105841	. Pin - Roll	1
8	87689	. Drum - Starter	1
9	87680	. Spring - Rewind	1
10	86053	. Shield - Spring	1
11	83748	. Shaft - Starter	1
12	87693	. Kit - Fan housing	1
13	87674	. . Guard - Sawdust	1

SUPER PRO 81

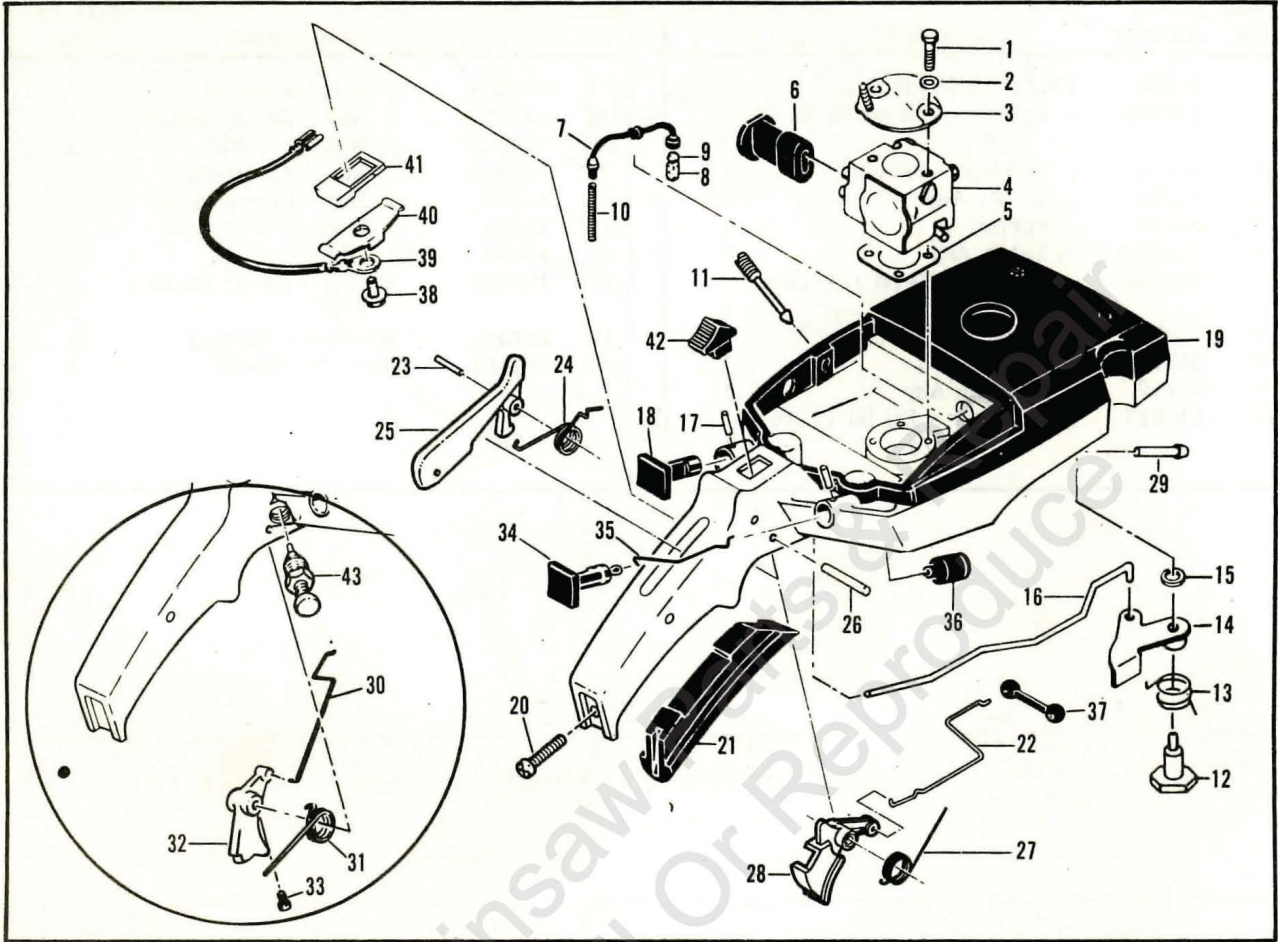

Figure 4. Fuel Tank Assembly.

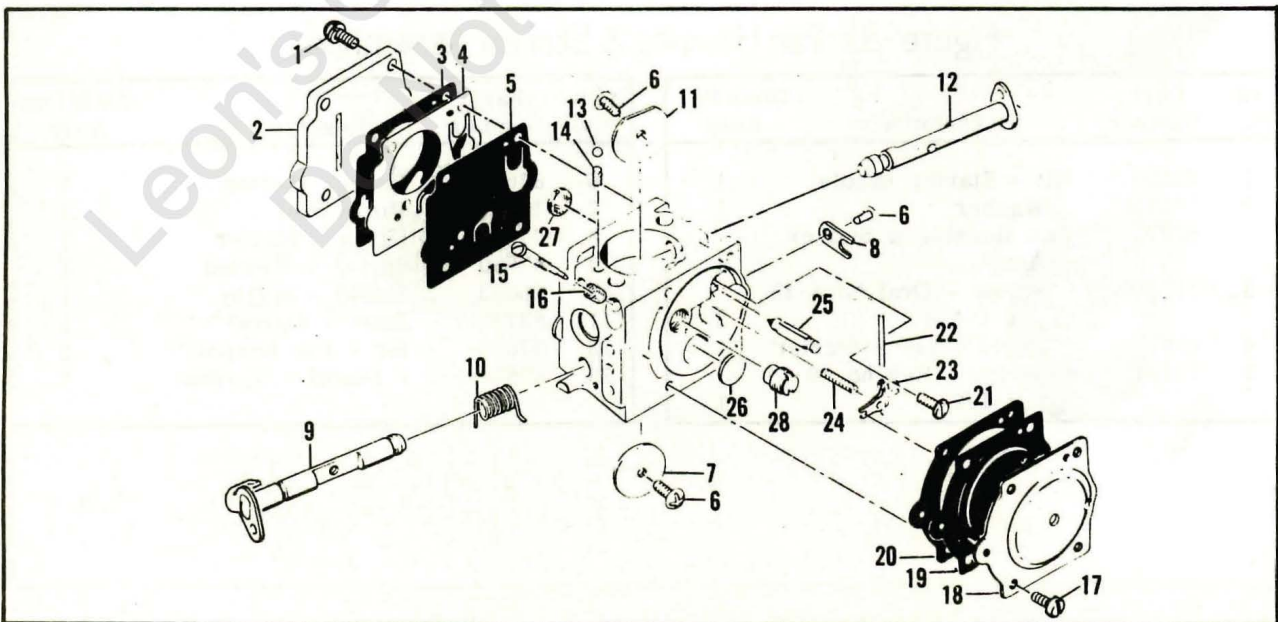

Figure 5. Carburetor Assembly.

Figure 4. Fuel Tank Assembly

Item No.	Part Number	Description	Units Per Asy.	Item No.	Part Number	Description	Units Per Asy.
1	110894	Screw - Hxhd 10-24 x 2-1/8	2	22	-92155	5. Rod - Throttle	1
2	-110964	Washer	2	23	-105654	5. Pin - Roll 1/8 x 7/8	1
3	83204	Bracket Assembly	1	24	-92154	5. Spring - Trigger release	1
4		Carburetor Asy (Fig. 5,6,7)		25	-92153	5. Release - Trigger	1
5	86189	Gasket - Carburetor	1	26	110378	. Pin - Roll 3/16 x 15/16	1
6	69629	1 Boot - Carburetor controls	1	27	-92152	5. Spring - Trigger	1
	85901	2 Boot - Carburetor controls	1	28	-92151	5. Trigger - Throttle	1
7	64848	Hose Assembly - Fuel	1	29	69600	. Nipple - Pulse line	1
8	63932	. Filter - Fuel	1	30	69632	6 Rod - Throttle	1
9	100440	. Washer	1	31	87178	6 Spring - Trigger	1
10	67944	Spring - Hose	1	32	88796	6 Trigger - Throttle	1
11	86273	Screw - Idle speed	1	33	110668	6 Screw - Filhd 8-36 x 5/8	1
12	69594	Pivot - Oiler lever	1	34	69630	Button - Choke	1
13	69781	Spring - Oiler lever	1	35	69631	Rod - Choke	1
14	69825	Lever Assembly - Oiler	1	36	69597	Boot - Control rod	2
15	105048	Washer - 3/16	1	37	69043	Snubber - Rod	1
16	69802	Rod - Oiler	1	38	110706	Screw - Filhd 8-18 x 1/2 (SEMS)	1
17	105673	Pin - Roll 3/32 x 9/16	2	39	83661	Wire Asy - Stop switch	1
18	63044	Button - Oiler	1	40	62451	Contact - Switch	1
19	-89880A	3 Tank Assembly - Fuel	1	41	62950A	Base - Switch	1
(19)	-87888A	4 Tank Assembly - Fuel	1	42	68846	Button - Switch	1
20	105722	. Screw - Filhd 1/4-20 x 1-3/8	1	43	85451	6 Latch Asy - Throttle	1
21	89400	. Insert - Handle grip	1				

- 1 Used on models with Carburetor Asy, P/N 87821 (Figure 6).
- 2 Used on models with Carburetor Asy, P/N 85916 (Figure 7).
- 3 Used on models with serial number prefix 11- and 12-.
- 4 Used on models with serial number prefix 14- and 15-.
- 5 Used on models with serial number prefix 15-.
- 6 Used on models with serial number prefix 11-, 12-, and 14-.

Figure 5. Carburetor Assembly

Item No.	Part Number	Description	Units Per Asy.	Item No.	Part Number	Description	Units Per Asy.
	89882	1 Carburetor Assembly	1	16	67502	3. Spring - Idle	1
1	67501	. Screw - Pump cover	4	17	70798	. Screw - Diaphragm cover	4
2	88731	. Kit - Pump cover	1	18	83761	. Cover - Diaphragm	1
3	88617	2. . Gasket - Cover	1	19	67499	3. Diaphragm - Metering	1
4	67498	3. Diaphragm - Check valve	1	20	67496	2. Gasket - Diaphragm	1
5	83114	3. Diaphragm - Fuel pump	1	21	67500	3. Screw - Lever pin	1
6	47690	3. Screw - Plate	3	22	67508	3. Pin - Lever	1
7	83762	. Plate - Throttle	1	23	67509	3. Lever - Inlet	1
8	67489	. Clip - Shaft	1	24	67503	3. Spring - Lever	1
9	67486	. Shaft Assembly - Throttle	1	25	67491	3. Valve - Needle	1
10	85981	. Spring - Throttle return	1	26	71690	3. Plug - 3/8	1
11	67490	. Plate - Choke	1	27	67507	3. Screen - Fuel	1
12	67488	. Shaft Assembly - Choke	1	28	90349	Jet - High speed (29)	1
13	100302	3. Ball - Choke friction	1		90350	Jet - High speed (28)	Alt.
14	67504	3. Spring - Choke friction	1		90351	Jet - High speed (26)	Alt.
15	90345	. Needle - Idle mixture	1		88619	3 Kit - Gasket	
					88620	Kit - Repair	

- 1 Used on models with serial number prefix 11- and 12-.
- 2 Contained in Gasket Kit, P/N 88619.
- 3 Contained in Repair Kit, P/N 88620.

SUPER PRO 81

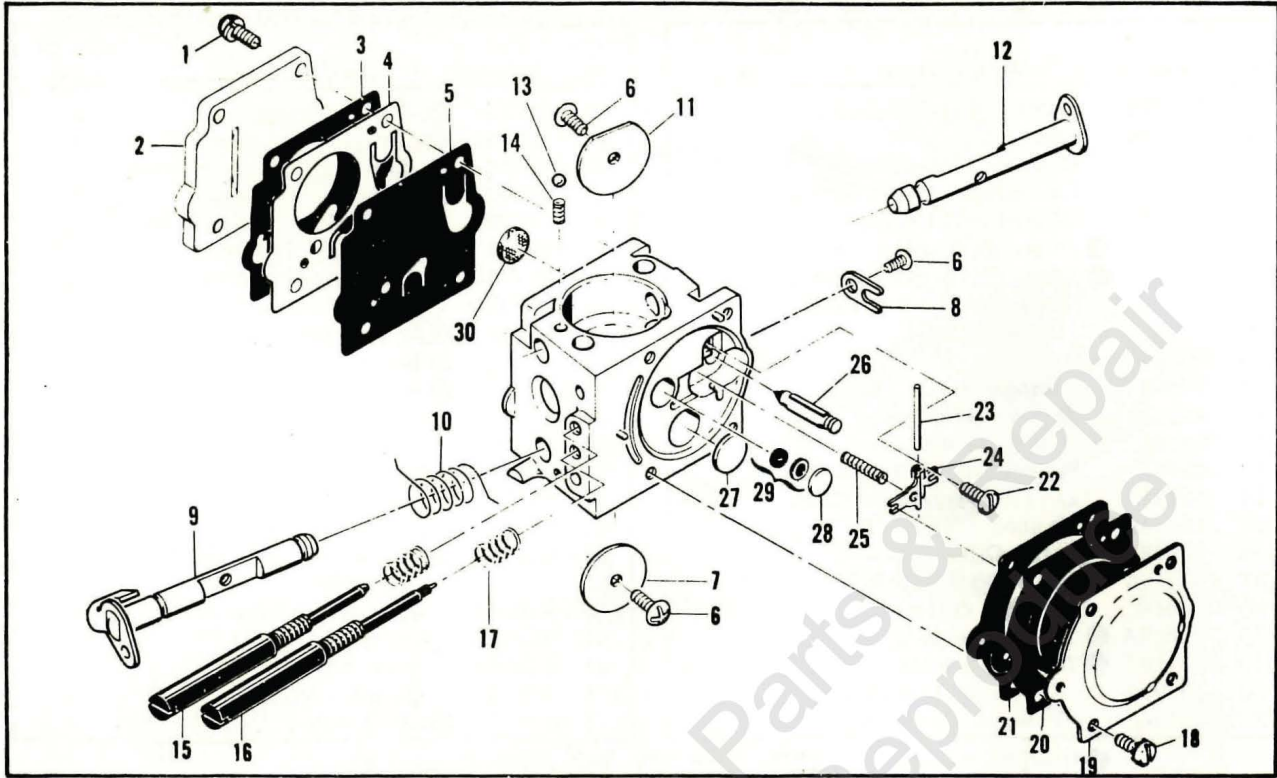

Figure 6. Carburetor.

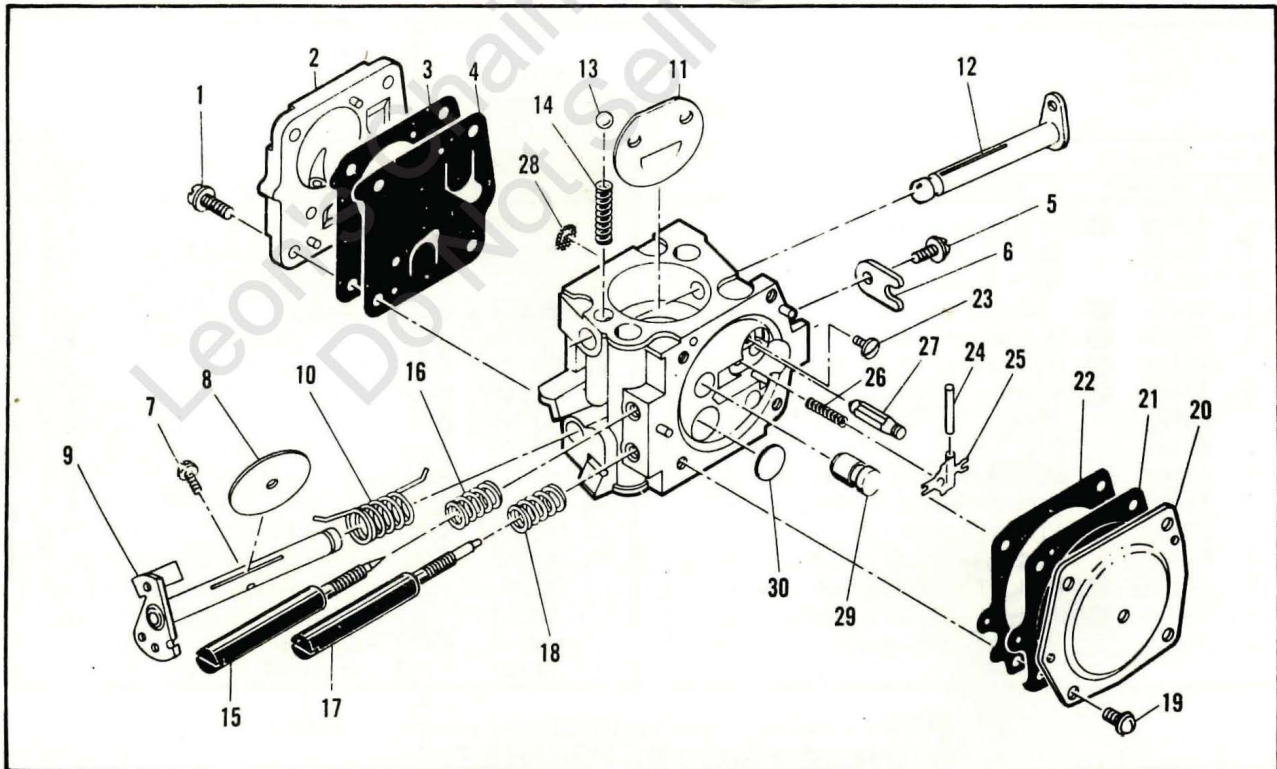

Figure 7. Carburetor.

Figure 6. Carburetor Assembly

Item No.	Part Number	Description	Units Per Asy	Item No.	Part Number	Description	Units Per Asy
	87821	① Carburetor Asy	1	17	67502	③ . Spring - Needle	2
1	67501	. Screw - Pump cover	4	18	70798	. Screw - Diaphragm	4
2	88731	. Kit - Pump cover	1	19	83761	. Cover - Diaphragm	1
3	88617	② . Gasket - Cover	1	20	67499	③ . Diaphragm - Metering	1
4	67498	③ . Diaphragm - Check valve	1	21	67496	② . Gasket - Diaphragm	1
5	83114	③ . Diaphragm - Fuel pump	1	22	67500	③ . Screw - Lever pin	1
6	47690	③ . Screw - Plate	3	23	67508	③ . Pin - Lever	1
7	83762	. Plate - Throttle	1	24	67509	③ . Lever - Inlet	1
8	67489	. Clip - Shaft	1	25	67503	③ . Spring - Lever	1
9	85980	. Shaft Asy - Throttle	1	26	67491	③ . Valve - Needle	1
10	85981	. Spring - Throttle return	1	27	71690	③ . Plug - 3/8	1
11	67490	. Plate - Choke	1	28	69506	③ . Plug - 5/16	1
12	67488	. Shaft Asy - Choke	1	29	83758	. Kit - Valve & Seat Asy	1
13	100302	③ . Ball - Choke friction	1	30	67507	③ . Screen - Fuel	1
14	67504	③ . Spring - Choke friction	1		67482	③ Gasket Kit	
15	85979	③ . Needle - High Speed	1		85987	Repair Kit	
16	85982	③ . Needle - Idle	1				

- ① Used on models with serial number prefix 14- and 15-.
- ② Contained in Gasket Kit , P/N 67482.
- ③ Contained in Repair Kit, P/N 85987.

Note: Carburetor Asy, P/N 87821 (SDC 38A, Figure 6) and Carburetor Asy, P/N 85916 (HS 111A, Figure 7) are alternates used on models with serial number prefix 14- and 15-.

Before ordering parts, identify the carburetor on the saw.

Figure 7. Carburetor Assembly

Item No.	Part Number	Description	Units Per Asy	Item No.	Part Number	Description	Units Per Asy
	85916	① Carburetor Asy	1	16	52936	. Spring - High Speed needle	1
1	52933	. Screw - Pump cover	4	17	86170	. Needle - Idle	1
2	66628	. Cover - Pump	1	18	67133	. Spring - Idle needle	1
3	66629	. Gasket - Cover	1	19	51721	. Screw - Diaphragm cover	4
4	66630	. Diaphragm - Fuel pump	1	20	83724	. Cover - Diaphragm	1
5	48780	. Screw - Clip retainer	1	21	66632	. Diaphragm - Metering	1
6	66646	. Clip - Throttle shaft	1	22	66633	. Gasket - Diaphragm	1
7	48780	. Screw - Plate	1	23	83479	. Screw - Lever pin	1
8	51720	. Plate - Throttle	1	24	66636	. Pin - Lever	1
9	83546	. Shaft Asy - Throttle	1	25	66638	. Lever - Metering	1
10	67136	. Spring - Throttle return	1	26	66404	. Spring - Lever	1
11	65856	. Plate - Choke	1	27	66637	. Valve - Needle	1
12	83725	. Shaft Asy - Choke	1	28	66623	. Screen - Fuel inlet	1
13	100071	. Ball - Choke friction	1	29	83729	. Check Valve - Nozzle	1
14	52930	. Spring - Choke friction	1	30	66622	. Plug - Welch	1
15	86169	. Needle - High speed	1				

- ① Used on models with serial number prefix 14- and 15-.

SUPER PRO 81

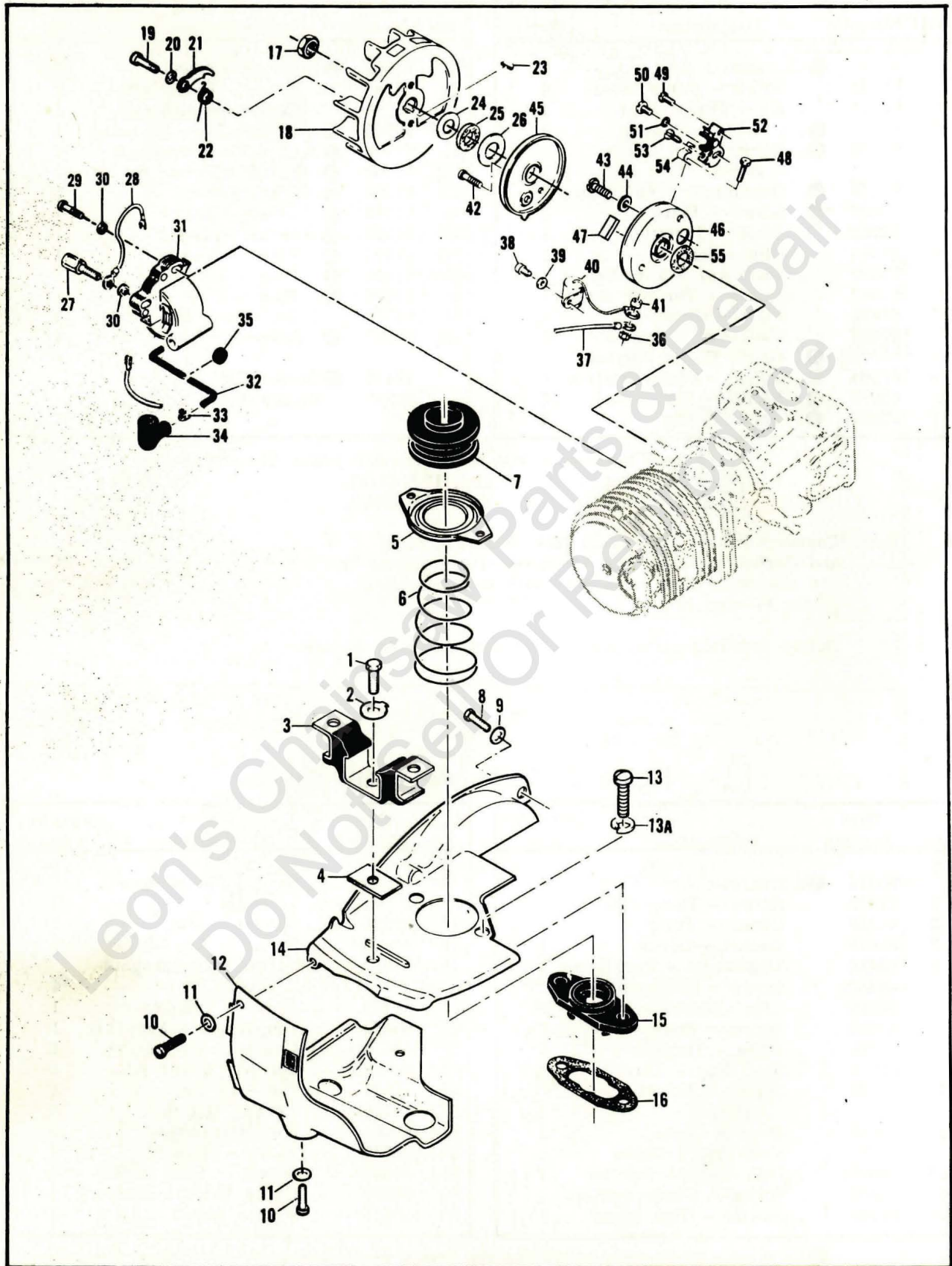

Figure 8. Flywheel & Ignition System.

Figure 8. Flywheel & Ignition System

Item No.	Part Number	Description	Units Per Asy
1	83811	Screw - Special	1
2	69924	Lockplate	1
3	91578	Mount - Rear	1
4	84619	Insulator	1
5	86175	Clamp Asy - Boot	1
6	86190	Spring - Ground	1
7	88834A	Boot - Port	1
8	110776	Screw - Fil hd 8-32 x 3/8	1
9	100057	Lockwasher	1
10	102500	Screw - Pan hd 10-24 x 1/2	3
11	100002	Washer - #10	3
12	86314A	Shroud - Lower	1
13	104396	Screw - Pan hd 10-24 x 3/4	2
13A	101194	Lockwasher - #10	2
14	88835A	Shroud - Upper	1
15	87844	Insulator - Inlet	1
16	88740	Gasket - Insulator	1
17	110703	Nut - Hx 3/8-24	1
18	86068	Flywheel	1
19	88804	Pivot - Pawl	2
20	83241	Washer - Special	2
21	67546	Pawl - Starter	2
22	67545	Spring - Pawl	2
23	100106	Key - Woodruff	1
24	67057	Washer - Thrust	1
25	67056	Seal - Breaker box cover	1
26	67054	Washer - Thrust	1
27	83512	Stud-Special	1
28	85798	Wire Asy-Ground	1
29	103947	Screw-Hx hd 10-24 x 1 (SEMS)	1
30	100002	Washer-#10	2

Item No.	Part Number	Description	Units Per Asy
31	87246A	Coil & Lamination Asy	1
32	50120	. Wire Asy-Spark plug	1
33	55061	. . Connector	1
34	85758	. . Boot	1
35	100268	. Grommet	1
36	100298	Nut - Hx 6-32	1
37	85796	Wire Asy - Primary	1
38	103672	Screw - Fil hd 8-32 x 1/2 (SEMS)	1
39	100080	Washer - #8	1
40	85358	Condenser	1
41	62365	Spacer - Breaker box	1
42	110584	Screw - Pan hd 8-32 x 3/4	1
	91852	Kit - Breaker box & cover	1
43	110489	. Screw - Pan hd 6-32 x 7/16	1
44	91838	. Washer - Special	1
45		. Cover - Breaker box	1
46		. Box - Breaker	1
47	54184	Wiper - Cam	1
48	110346	Screw - Hx hd 6-32 x 3/4	1
49	110811	Screw - Pan hd 8-32 x 3/8	1
50	-110969	Screw-Hx hd 8-32 x 1/2	1
51	105976	Washer - #8	1
52	88808	Breaker Asy	1
53	110706	Screw - Pan hd 6-32 x 7/16 s/t	1
54	83126	Strap - Conduction	1
55	67051	Seal - Breaker box	1

Leon's Do Not Sell Or Profit From This

SUPER PRO 81

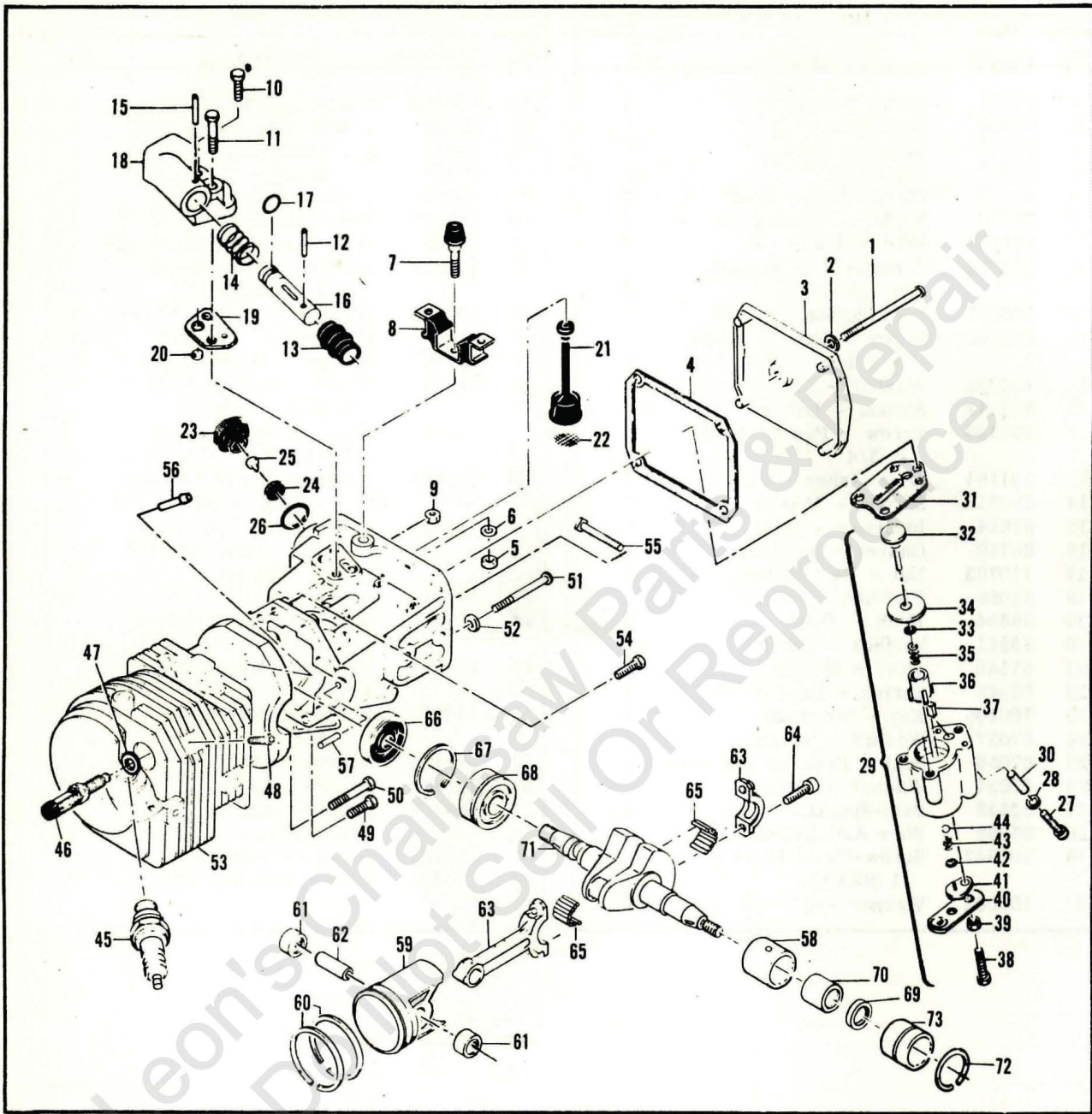

Figure 9. Powerhead & Oiler Assemblies.

Figure 9. Powerhead & Oiler Assemblies

Item No.	Part Number	Description	Units Per Asy	Item No.	Part Number	Description	Units Per Asy
1	110291	Screw - Pan hd 10-24 x 2-5/8	1	39	100251	. Nut - Hx 8-32	1
2	110921	Washer - Sealing	1	40	89114	① . Clamp - Pump	1
3	86304	Cover - Oil tank	1	41	62407	. Cover - Outlet valve	1
4	86306	Gasket - Cover	1	42	106104	. "O" Ring	1
5	101143	Nut - Hx 1/4-20	1	43	-92844	. Spring - Outlet valve	1
6	102523	Washer - 1/4	1	44	102809	. Ball - Outlet valve	1
7	69832	Bumper - Front	1	45	63432	Spark Plug (B, D, E)	1
8	91582	Mount - Front	1		63097	Spark Plug (A)	1
9	100955	Nut - Hx 8-32	1	46	87866	Valve - DSP	1
10	110670	Screw - Fil hd 8-32 x 1/2	1	47	85505	Washer - Valve	1
11	105245	Screw - Fil hd 8-32 x 1 (SEMS)	1	48	110681	Screw - Skt hd 10-24 x 1/4	1
12	105673	Pin - Roll 3/32 x 9/16	1	49	110288	Screw - Hx hd 8-32 x 3/4	1
13	69586	Boot - Plunger	1	50	110644	Screw - Hx hd 8-32 x 1-1/2	1
14	69585	Spring - Plunger	1	51	62105	Screw Asy - Sealing	4
15	101556	Pin - Roll 1/8 x 5/8	1	52	62842	. Washer - Sealing	4
16	91219	Plunger - Pump	1	53	-92450A	② Kit - Cyl., C'case, Piston	1
17	105614	"O" Ring	1	54	110288	. Screw - Hx hd 8-32 x 3/4	2
18	91218	Body - Oil pump	1	55	62065	. Bolt - Bar mounting	2
19	91669	Gasket - Oil pump	1	56	69600	. Nipple - Pulse line	1
20	91668	Valve - Oiler	1	57	110851	. Pin - Dowel	1
21	91672	Hose - Oil	1	58	87152	. Insert - Bearing	1
22	51506	. Screen - Hose	1	59	92518	② . Piston Asy (Identified A)	1
23	87270	Cap - Oil tank	1		92519	② . Piston Asy (Identified B)	1
24	87269	. Retainer - Valve	1		92520	② . Piston Asy (Identified C)	1
25	86402	. Valve	1	60	87854	. . Ring Set - Piston	1
26	101148	"O" Ring	1	61	110590	. . Bearing - Needle	2
27	110865	Screw - Skt hd 10-24 x 7/8	1	62	69020	Pin - Piston	1
28	100003	Washer - #10	1	63	85237	Connecting Rod Asy	1
29	-89115A	Pump Asy - Pulse	1	64	61627A	. Screw - Special	2
30	91774	. Sleeve	1	65	85246	. Roller - (set of 22)	1
31	-92818	. Seal - Pulse pump	1	66	61618	Seal - Oil	1
32	60260A	. Piston Asy - Pump	1	67	63464	Ring - Snap	1
33	105603	. "O" Ring	1	68	63429B	Bearing - Ball	1
34	86182	. Ring - Piston	1	69	110260	Seal - Oil	1
35	60259	. Spring - Piston	1	70	104357	Bearing - Needle	1
36	62227	. Sleeve - Adjustment	1	71	86193	Crankshaft	1
37	91259	. Pad - Oil pump	1	72	63699	③ Ring - Bearing insert	1
38	110386	. Screw - Hx hd 8-32 x 1	1	73	63701	③ Insert - Bearing	1

① Used on models with serial number prefix 11-, 12-, 14-.

② Cylinder/Crankcase and Piston Assembly Kits are furnished in matched sets and are identified by a matching letter marking "A", "B" or "C" on both cylinder and piston. Order replacement pistons identified with the letter identification on the cylinder. For piston replacement in an unmarked cylinder, use Piston Assembly, P/N 92519, identified "B".

③ Used on models with serial number prefix 11-.

SUPER PRO 81

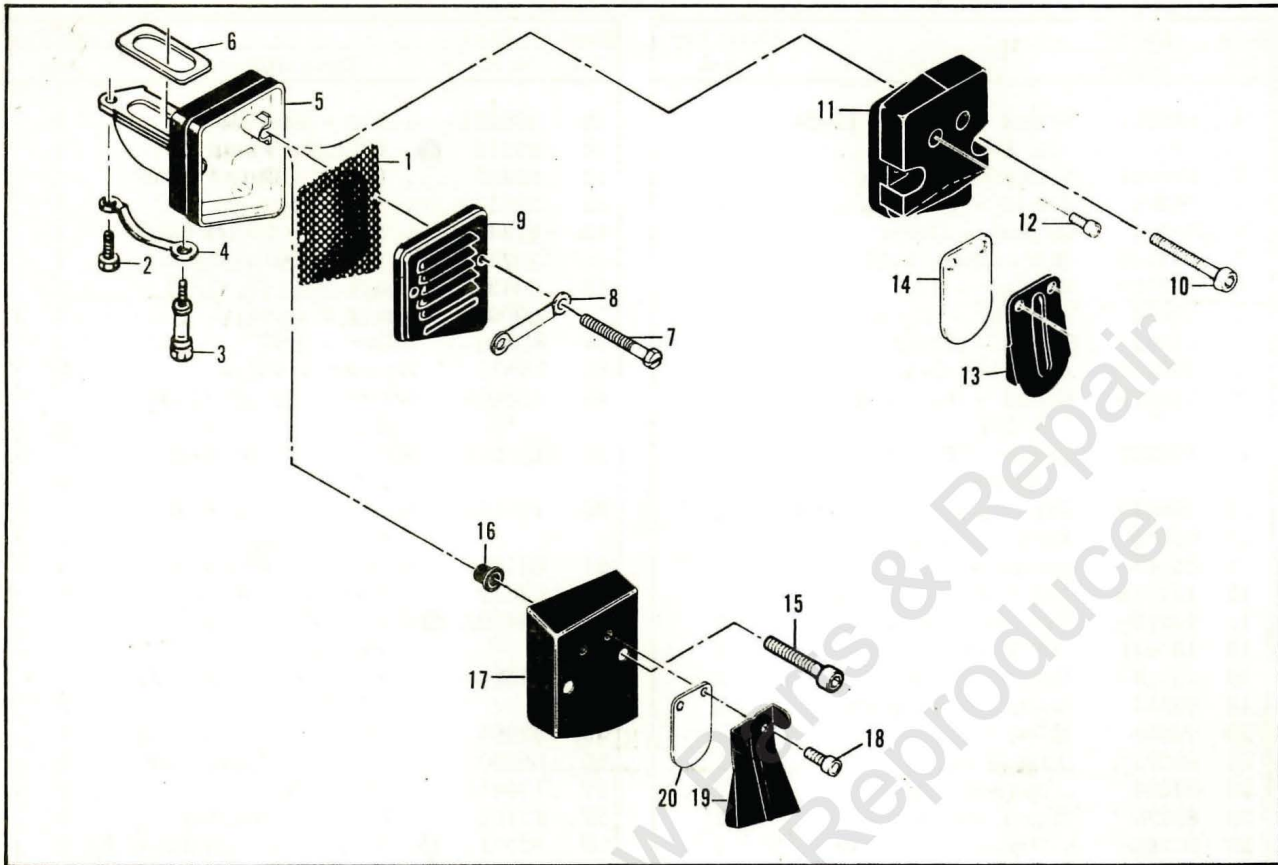

Figure 10. Muffler Assembly

Item No.	Part Number	Description	Units Per Asy.
1	84580	Baffle - Muffler	1
2	110529	Screw - Hx hd 10-24 x 1/2	1
3	84578	Screw - Special	1
4	84579	Plate - Lock	1
5	84572	Body & Duct Asy	1
6	84577	Gasket - Muffler	1
7	103353	① Screw - Hx hd 10-24 x 1-1/2 (A, B, D)	2
8	86050	① Plate - Lock (A, B, D)	1
9	84603	① Cover - Muffler (A, B, D)	1
10	-110440	② Screw - Skt hd 10-24 x 1-3/4	2
11	-84581A	② Kit - Cover & Valve Asy	1

Item No.	Part Number	Description	Units Per Asy.
12	110472	② . Screw - Skt hd 8-32 x 5/16	2
13	87193	② . Stop - Reed	1
14	85585	② . Valve - Reed	1
15	-110440	③ Screw - Skt hd 10-24 x 1-3/4 (A)	2
16	-92539	③ Bushing - Spacer (A)	2
17	-92538	③ Cover - Cooling (A)	1
18	110472	③ Screw - Skt hd 8-32 x 5/16 (A)	2
19	-92552	③ Stop - Reed (A)	1
20	85585	③ Valve - Reed (A)	1

- ① Used on models with serial number prefix 11- and 12-.
- ② Used on models with serial number prefix 14-; also 15- with model number suffix letter B, D, and E.
- ③ Used on models with serial number prefix 15-.

Accessories

Part Number	Description
86218	Kit - Preheater
86209	Kit - Duct, Valve, Guard
84597	Baffle - Spark arrester
86943	Kit - Sprocket & Drum 8T .375P
86342	Kit - Sprocket & Drum 7T .404P
86419	Guide - Timing
92455	Rope - Starter (100 ft)

Part Number	Description
85968	Guard - Hand
87839	Adapter - Bar mounting
89494	Wrench - Clutch retaining
63432	Spark Plug (standard)
63097	Spark Plug (hotter)
65778	Spark Plug (cooler)
63746	Scrench

Service Specifications

Spark Plug Gap	-	.025 inch (.63 mm)
Lamination Gap	-	.010 to .012 inch (.25 to .30 mm)
Breaker Point Gap	-	.019 to .020 inch (.48 to .51 mm)
Timing	-	26° BTDC
Clutch Engagement Speed		2800 to 3000 R.P.M.
Torques	-	Connecting Rod Screws: 65 to 70 inch/pounds (75 to 81 cm/kg)
		Clutch Nut: 160 to 170 inch/pounds (184 to 196 cm/kg)
		Flywheel Nut: 265 to 325 inch/pounds (305 to 374 cm/kg)

 **McCULLOCH**



● MANUFACTURING ● SALES ● SERVICE ●

McCULLOCH CORPORATION

P.O. BOX 92180, LOS ANGELES, CALIFORNIA 90009

INTERNATIONAL DIVISIONS:

LOS ANGELES, CALIFORNIA, P.O. BOX 92181
SINGAPORE, GOLDHILL PLAZA, SINGAPORE II
SAO PAULO, BRAZIL, CAIXA POSTAL 21-492

McCULLOCH OF CANADA LTD.

6338 VISCOUNT ROAD, MALTON, ONTARIO L4V 1H4, CANADA

McCULLOCH OF EUROPE, N. V.

GEERDEGEM SCHONENBERG, 299 2800 MECHELEN, BELGIUM

McCULLOCH OF AUSTRALIA PTY., LTD.

P.O. BOX 223, SEVEN HILLS, N.S.W. 2147, AUSTRALIA