

SUPER 10- 10 & SUPER 10-10A CHAIN SAWS

MODEL NO. 600005 - SERIAL NOS. PREFIXED 15-, A13-
MODEL NO. 600007 - SERIAL NOS. PREFIXED 14-, A11-

ILLUSTRATED PARTS LIST

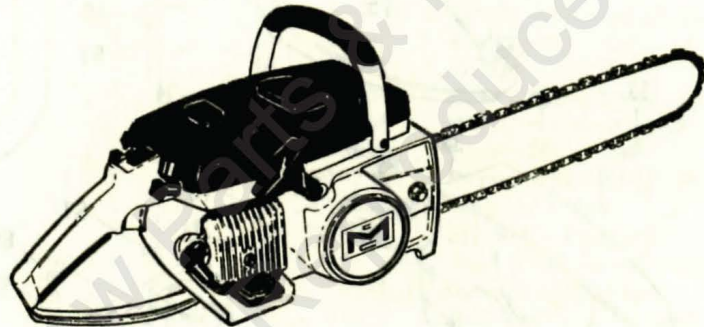

JULY 1970

The policy of McCulloch Corporation is one of continual improvement in design, manufacturing and engineering advancement wherever possible to assure still finer two-cycle power tools. Hence, specifications, equipment, colors, design and manufacturer's suggested list prices are subject to change without notice and McCulloch Corporation reserves the right to make such changes without prior notification or obligation to backfit or supply backfit components for units previously shipped from the factory.

	Page
Figure 1. Engine Exploded View - General	2
Figure 2. Clutch Guard & Starter Assembly	4
Figure 3. Fuel Tank Assembly	4
Figure 4. Carburetor Assembly	6
Figure 5. Powerhead Assembly	8

 **McCULLOCH**

COPYRIGHT 1970 U.S.A.--
McCULLOCH CORPORATION

84372

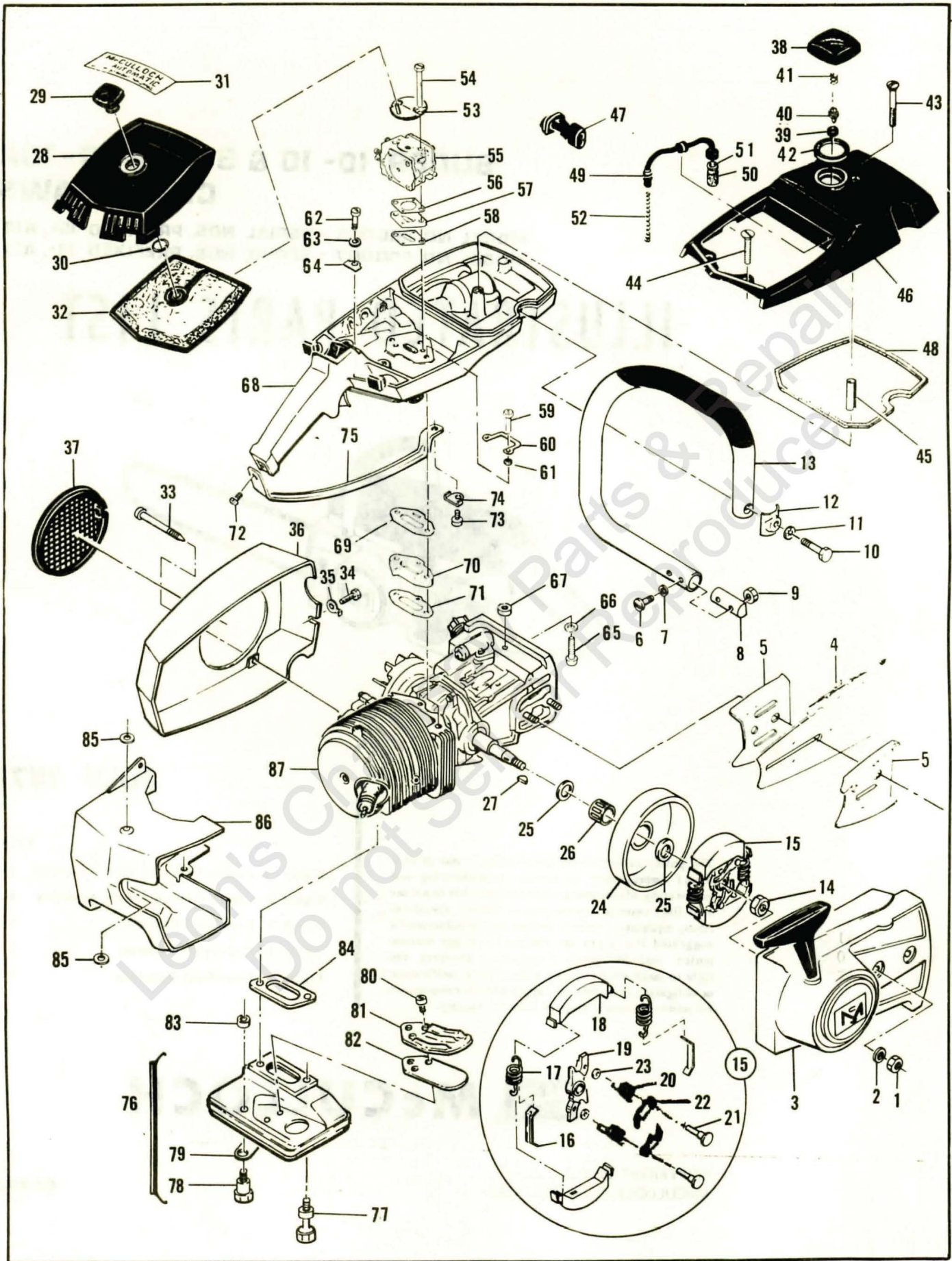

Figure 1. General

FIGURE 1. GENERAL

Item No.	Part Number	Description	Units Per Assy
1	110454	Nut - Hex 5/16-24	2
2	100440	Washer - 5/16	2
3		Clutch Guard & Starter Assy (See Figure 2)	
4		Bar & Chain (See Accessories)	
5	64325	Plate - Bar protector	2
6	102761	Screw - Hex hd 10-24 x 7/8	2
7	100352	Washer - #10	2
8	61678	Plug - Nut retainer	1
9	101326	Nut - Hex 10-24	2
10	102130	Screw - Hex hd 1/4-20 x 1-1/2	1
11	100153	Lockwasher - 1/4	1
12	63484	Clamp - Frame	1
13	69054	Frame & Grip Assy	1
14	110594	Nut - Hex 3/8-24	1
15	83655	Clutch Assy	1
16	64583	. Retainer	2
17	83223	. Spring - Clutch	2
18	67233	. Shoe - Clutch	2
19	83671	. Rotor Assy	1
20	83654	. . Spring - Pawl	2
21	83653	. . Rivet	2
22	24093	. . Pawl - Clutch	2
23	65473	. . Washer - Special	2
24	65370	Kit - Sprocket & Drum Assy	1
25	61692	. Shim	2
26	110330	Bearing	1
27	103879	Key - Woodruff	1
28	68530	Cover Assy - Air cleaner	1
29	68529	. Knob - Cover	1
30	110565	. Ring - Retaining	1
31	* 69932	Nameplate	1
	** 69897	Nameplate	1
32	69922	Filter - Air	1
33	62978	Screw - Special	3
34	102762	Screw - Hex hd 10-24 x 1/2	1
35	69890	Lockplate	1
36	83521	Kit - Fan Housing	1
37	55615	. Guard - Flywheel	
38	68531	Cap Assy - Fuel	1
39	68533	. Plug	1
40	63041	. Valve	1
41	63040	. Spring	1
42	69767	. Gasket	1
43	110402	Screw - Oval hd 12-24 x 2-3/8	1

Item No.	Part Number	Description	Units Per Assy
44	103579	Screw - Flat hd 10-24 X 1	2
45	69686	Spacer - Fuel tank cover	1
46	-84252	Cover - Fuel tank	1
47	-84253	Boot - Carburetor adjustment	1
48	69345	Gasket - Cover	1
49	64848	Hose Assy - Fuel	1
50	63932	. Filter - Fuel	1
51	100440	. Washer - 5/16	1
52	67944	Spring - Hose stiffener	1
53	83204	Kit - Bracket Assy	1
54	103357	. Screw - Hex hd 10-24 x 2-1/4	2
55		Carburetor Assy (See Figure 4)	
56	-83059	Gasket - Carburetor	1
57	-84078	Spacer - Carburetor	1
58	-84081	Gasket - Spacer	1
59	110570	Screw - Hex hd 12-24 x 1-3/8	2
60	68582	Lockplate	1
61	102115	Washer - #12	2
62	110568	Screw - Hex hd 12-24 x 1-1/8	1
63	64856	Washer - Special	1
64	69516	Lockplate	1
65	102660	Screw - Skt hd 10-24 x 7/8	1
66	100003	Washer - #10	1
67	69772	Spacer - Fuel tank	1
68		Fuel Tank Assy (See Figure 3)	
69	-84082	Gasket - Fuel tank	1
70	-84079	Insulator - Fuel tank	1
71	-84082	Gasket - Insulator	1
72	106078	Screw - Hex hd 10-24 x 7/16(SEMS)	1
73	110566	Screw - Hex hd 12-24 x 5/8	1
74	68508	Lockplate	1
75	69838	Brace - Handle	1
76	68863	Kit - Muffler	1
77	67838	. Screw - Muffler long	2
78	67837	. Screw - Muffler short	1
79	83993	. Lockplate	1
80	110563	. . Screw - Skt hd 8-32 x 1/4	2
81	83069	. . Stop - Reed	1
82	64785	. . Reed	1
83	63993	Gasket - Muffler screw	1
84	-84007	Gasket - Muffler	1
85	68581	Insulator - Shroud	2
86	67910	Shroud	1
87		Powerhead Assy (See Figure 5)	

* Model No. 600005

** Model No. 600007

Part numbers which have changed since the previous printing of the illustrated parts list covering these saws, are indicated by a dash (-) preceding the new part number.

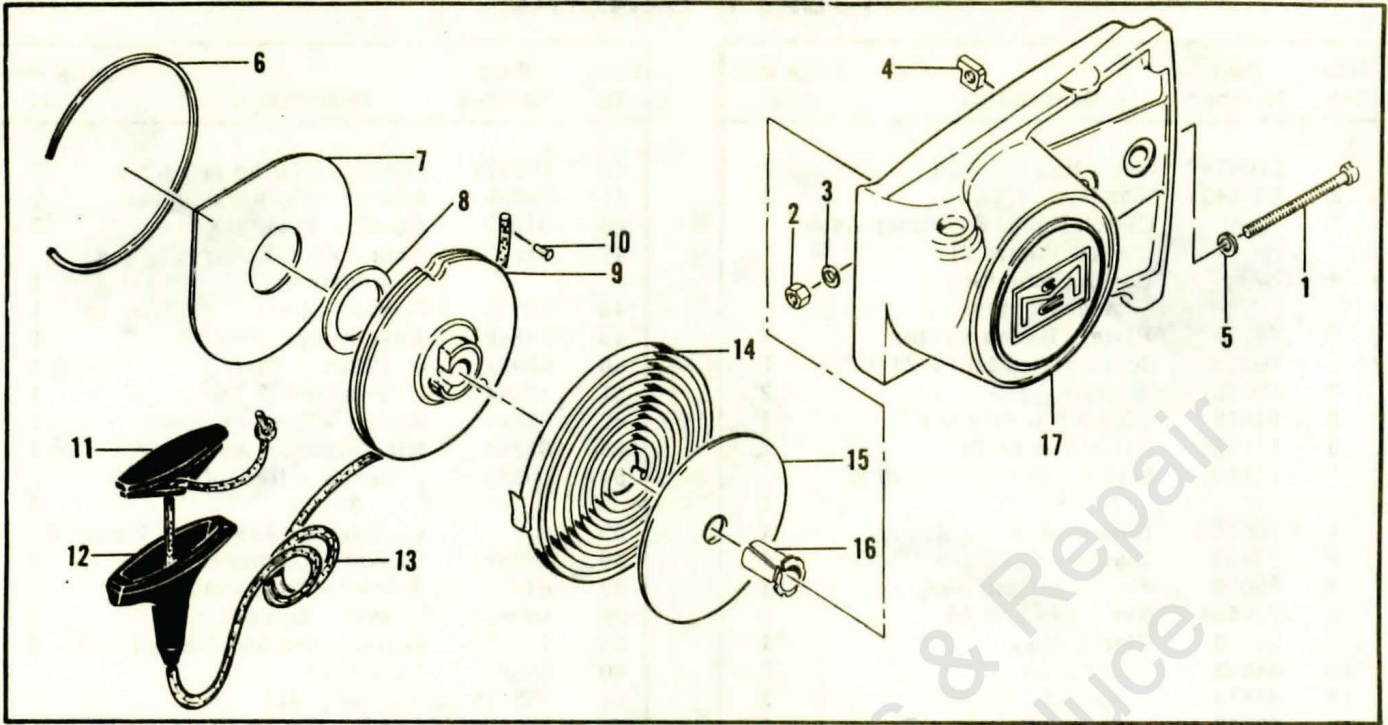

Figure 2. Clutch Guard and Starter Assembly

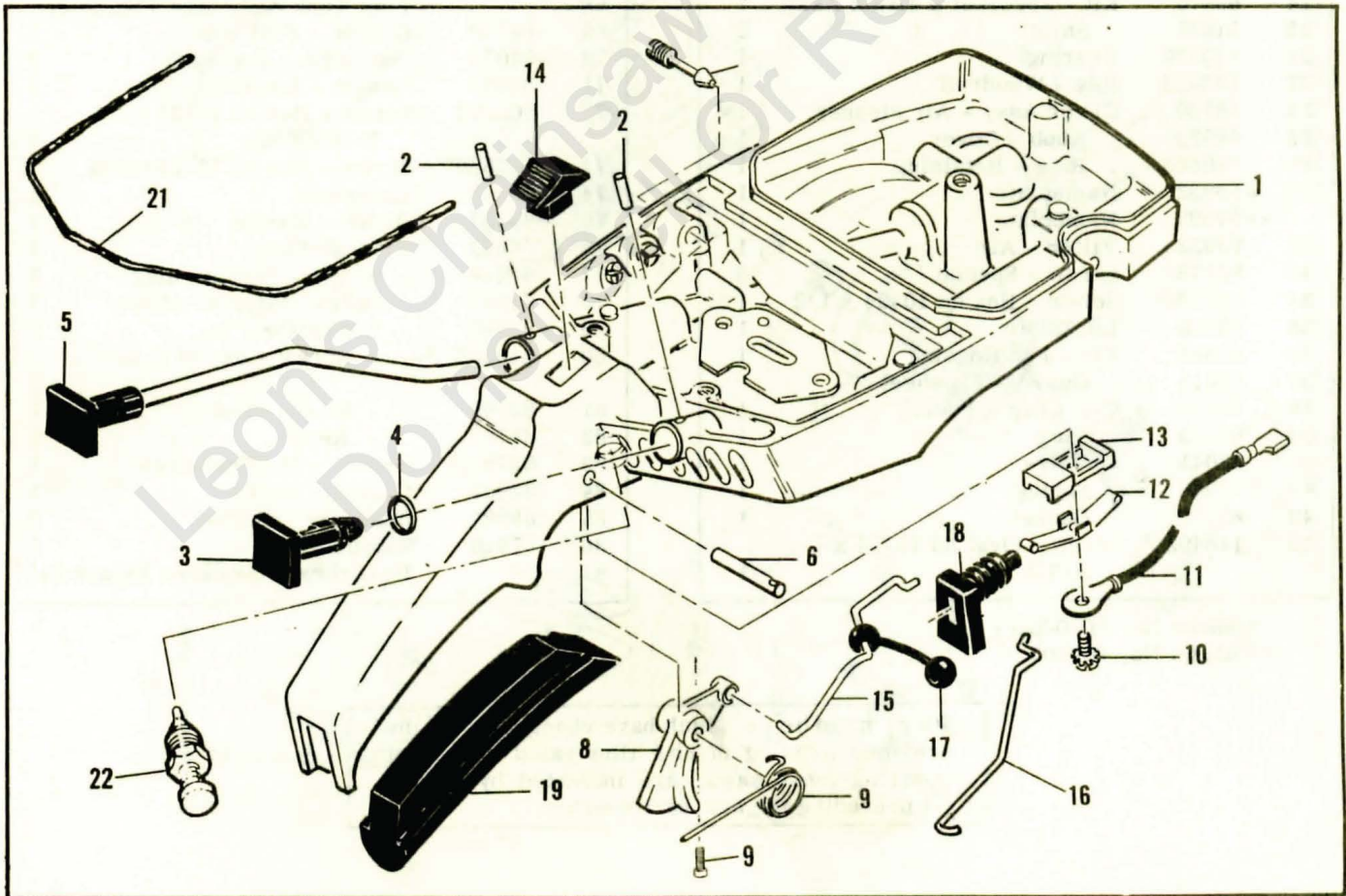

Figure 3. Fuel Tank Assembly

FIGURE 2. CLUTCH GUARD AND STARTER ASSEMBLIES

Item No.	Part Number	Description	Units Per Assy
	83850	Clutch Guard Assy	1
1	102144	. Screw - Bar adjusting	1
2	102067	. Nut - Hex 10-24	1
3	110387	. Washer - Wave	1
4	61705	. Nut - Bar adjusting	1
5	110264	. Washer - #10	1
6	67205	. Retainer - Shield	1
7	63985	. Shield - Dust	1
8	63986	. Washer - Thrust	1

Item No.	Part Number	Description	Units Per Assy
9	83651	. Drum - Starter	1
10	110470	. Rivet - Starter rope	1
11	62191A	. Insert - Handle	1
12	62190A	. Handle - Starter	1
13	69964	. Rope - Starter	1
14	83334	. Spring - Rewind	1
15	63987	. Shield - Spring	1
16	61635A	. Bushing - Nylon	1
17	83569	. Guard - Clutch	1

FIGURE 3. FUEL TANK ASSEMBLY

Item No.	Part Number	Description	Units Per Assy
1	-84183	Fuel Tank Assy	1
2	105673	Pin - Roll	2
3	69041	Button - Choke	1
4	101056	"O" Ring	1
5	64871	Button & Rod Assy	1
6	110378	Pin - Roll	1
7	65734	Spring - Throttle return	1
8	67224	Trigger	1
9	-110668	Screw - Fil hd 8-36 x 5/8	1
10	103672	Screw - Fil hd 8-32 x 1/2 (SEMS)	1
11	62973A	Wire Assy - Stop switch	1

Item No.	Part Number	Description	Units Per Assy
12	62451	Contact - Switch	1
13	62950A	Base - Switch	1
14	62951	Button - Switch	1
15	68170	Rod - Throttle	1
16	69042	Rod - Choke	1
17	69043	Snubber - Control rod	1
18	68522	Seal - Throttle rod	1
19	64872	Grip - Handle	1
20	67271	Screw - Idle speed	1
21	*69564	Seal - Airbox	AR
22	-83051	Throttle Lock Assy	1

*Furnished on a 12-1/2 inch strip containing
9 beads of sealant (enough for 9 replacements).

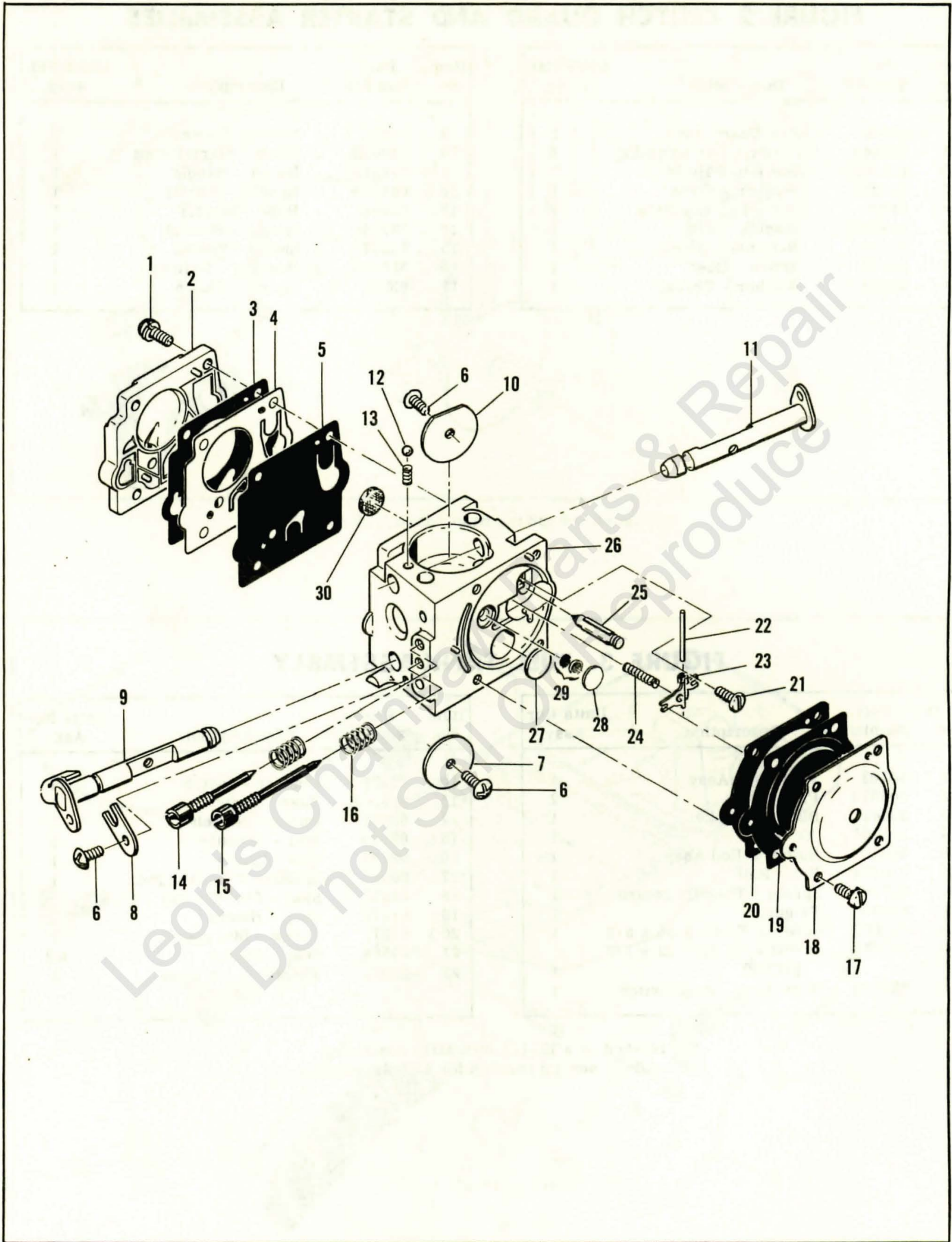

Figure 4. Carburetor Assembly

FIGURE 4. CARBURETOR ASSEMBLY

Item No.	Part Number	Description	Units Per Assy
	67379	Carburetor Assy (McCulloch SDC 2)	1
1	67501	. Screw - Pump cover	4
2	83760	. Cover - Pump	1
3	*67495	. Gasket - Cover	1
4	*67498	. Diaphragm - Check valve	1
5	*83114	. Diaphragm - Fuel pump	1
6	47690	. Screw - Plate	3
7	67487	. Plate - Throttle	1
8	67489	. Clip - Shaft	1
9	67486	. Shaft Assy - Throttle	1
10	67490	. Plate - Choke	1
11	67488	. Shaft Assy - Choke	1
12	*100302	. Ball - Choke friction	1
13	*67504	. Spring - Choke friction	1
14	*67506	. Needle - High speed	1
15	*67505	. Needle - Idle	1
16	*67502	. Spring - Needle	2

Item No.	Part Number	Description	Units Per Assy
17	70798	. Screw - Diaphragm cover	4
18	83761	. Cover - Diaphragm	1
19	*67499	. Diaphragm - Metering	1
20	*67496	. Gasket - Diaphragm	1
21	*67500	. Screw - Lever pin	1
22	*67508	. Pin - Lever	1
23	*67509	. Lever - Inlet	1
24	*67503	. Spring - Lever	1
25	*67491	. Valve - Needle	1
26	67483	. Body Assy - Carburetor	1
27	*71690	. Plug - 3/8	1
28	*69506	. Plug - 5/16	1
29	83758	. Kit - Valve & Seat Assy	1
30	*67507	. Screen - Fuel	1
	*67482	Gasket Set	
	67481	Repair Kit	

*Indicates parts included in Repair Kit, P/N 67481.

Leon's Chainsaw Parts & Repairs
Do not Sell Or Reprint

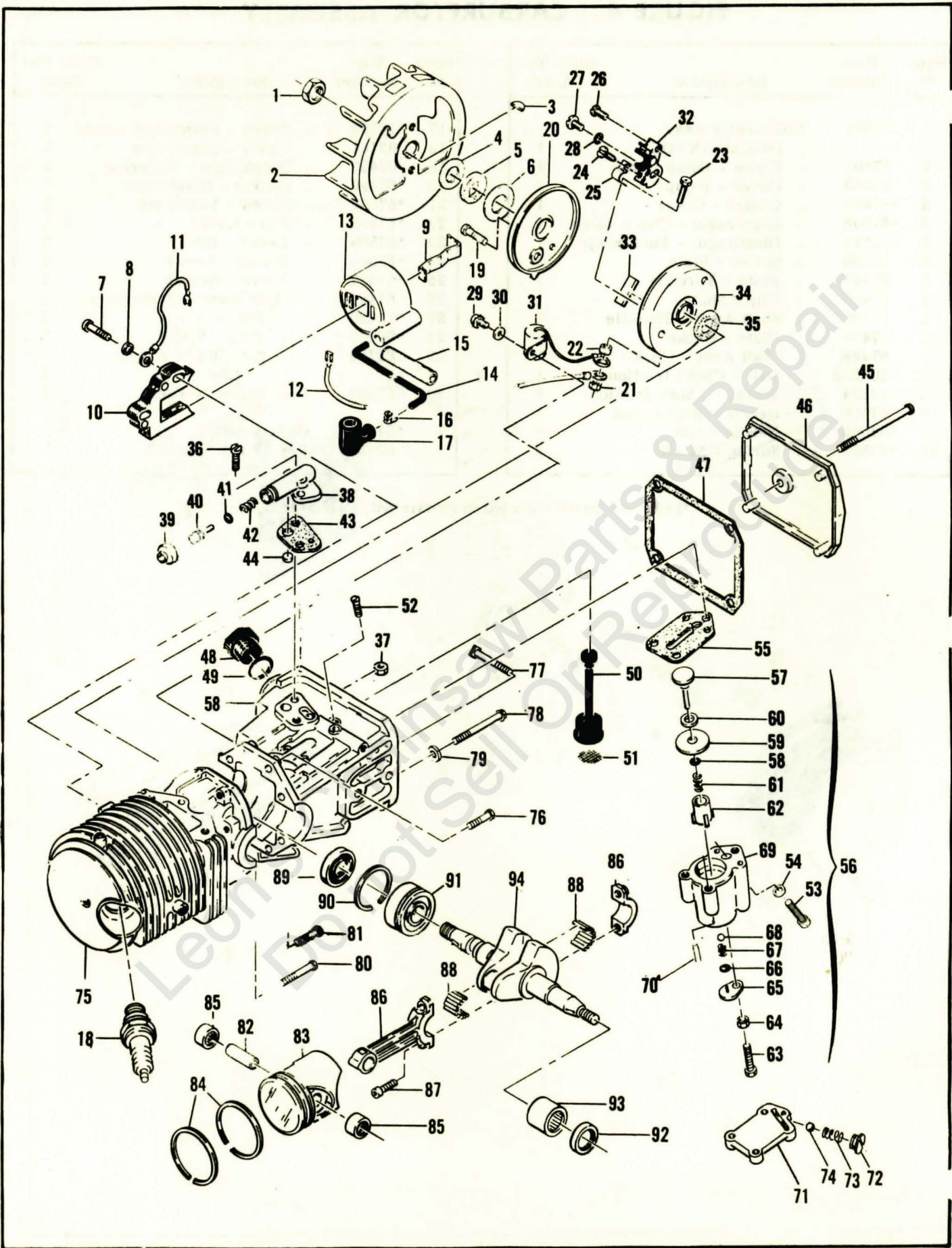

Figure 5. Powerhead Assembly

FIGURE 5. POWERHEAD ASSEMBLY

Item No.	Part Number	Description	Units Per Assy
1	110594	Nut - Hex 3/8-24	1
2	-84681	Flywheel Assy	1
3	103879	Key - Woodruff	1
4	67057	Washer - Thrust	1
5	67056	Seal	1
6	67054	Washer - Thrust	1
7	110127	Screw - Hex hd 10-24 x 7/8 (SEMS)	2
8	100003	Washer - #10	2
9	51253	Retainer - Coil	1
10	68164	Lamination Assy	1
11	62819	Wire Assy - Ground	1
12	69344	Wire Assy - Primary	1
13	69798	Coil & Terminal Assy	1
14	69966	. Wire & Sleeve Assy - Spark plug	1
15	67127	. . Sleeve - Spark plug wire	1
16	62932	. . Connector	1
17	62926	. . Boot	1
18	63097	Spark Plug - AC CS45T	1
19	110349	Screw - Rd hd 8-32 x 3/4	1
20	62362	Cover - Breaker box	1
21	100298	Nut - Hex 6-32	1
22	62365	Spacer - Breaker screw	1
23	110346	Screw - Hex hd 6-32 x 3/4	1
24	110489	Screw - Pan hd 6-32 x 7/16	1
25	83126	Strap - Conduction	1
26	100934	Screw - Rd hd 8-32 x 3/8	1
27	110445	Screw - Tr hd 8-32 x 3/8	1
28	105976	Washer - #8	1
29	103672	Screw - Fil hd 8-32 x 1/2	1
30	100080	Washer - #8	1
31	61650	Condenser	1
32	66231	Breaker Assy	1
33	54184	Wiper	1
34	83125	Box - Breaker	1
35	67051	Seal	1
36	110623	Screw - Fil hd 8-32 x 1/2	2
37	100955	Nut - Hex 8-32	1
38	62261A	Housing - Pump	1
39	62262	Cap - Housing	1
40	62266	Plunger - Pump	1
41	101056	"O" Ring	1
42	66687	Spring	1
43	62230	Gasket	1
44	62909	Valve	1
45	110291	Screw - Pan hd 10-24 x 2-5/8	1
46	63072	Cover - Oil tank	1

Item No.	Part Number	Description	Units Per Assy
47	62116	Gasket - Cover	1
48	68809	Cap - Oil tank	1
49	101148	"O" Ring	1
50	62123B	Hose Assy - Oil	1
51	51506	. Screen - Hose	1
52 *	110333	Screw - Oval hd 8-32 x 1/2	3
53**	-102660	Screw - Skt hd 10-24 x 7/8	1
54**	-24236	Washer - Special	1
55 *	62274	Gasket - Pulse pump	1
**	-83790	Gasket - Pulse pump	1
56**	-83786	Pump Assy - Pulse	1
57**	60260A	. Piston Assy - Pump	1
58**	104001	. "O" Ring	1
59**	60263	. Ring - Pump piston	1
60**	60937	. Washer - Teflon	1
61**	60259	. Spring - Piston	1
62**	62227	. Sleeve - Adjustment	1
63**	110386	. Screw - Hex hd 8-32 x 1	1
64**	100251	. Nut - Hex 8-32	1
65**	62407	. Cover - Outlet valve	1
66**	106104	. "O" Ring	1
67**	62885A	. Spring - Outlet valve	1
68**	102809	. Ball	1
69**	-83787	. Body Assy - Pump	1
70**	110643	. Screw - Set 8-32 x 7/16	1
71 *	68711	Body Assy - Check valve	1
72 *	68714	. Screw - Special	1
73 *	63034	. Spring - Check valve	1
74 *	100071	. Ball - 5/32 dia.	1
75 *	69993	Crankcase Assy	1
**	-84113	Crankcase Assy	1
76	110288	. Screw - Hex hd 8-32 X 3/4	2
77	62065	. Bolt - Bar mounting	2
78	62105	Screw Assy - Sealing	4
79	62842	. Washer - Sealing	4
80	110618	Screw - Hex hd 8-32 X 1-3/8	1
81	110288	Screw - Hex hd 8-32 X 3/4	1
82	61649	Pin - Piston	1
83	69212	Piston Assy	1
84	62814	. Ring Set - Piston	1
85	-103085	. Bearing - Needle	2
86	65401	Connecting Rod Assy	1
87	61627A	. Screw - Special	2
88	63225	. Roller - Needle (set of 20)	1
89	67906	Oil Seal	1
90	63464	Ring - Snap	1
91	67905	Bearing - Ball	1
92	110260	Oil Seal	1
93	104357	Bearing - Needle	1
94	63336	Crankshaft	1

* Model No. 600005

** Model No. 600007

**Super 10-10
Super 10-10A**

SERVICE SPECIFICATIONS

Spark Plug Gap -----	0.025 in.
Lamination Gap -----	0.010 to 0.015 in.
Breaker Point Gap -----	0.018 in.
Carburetor Adjustment	
Idle Needle - Preliminary adjustment 1 turn open. Adjust for smooth idle and acceleration.	
Main Needle - Preliminary adjustment 1 turn open. Adjust for maximum power under load.	
Torque Values	
Flywheel Nut -----	240 to 300 inch-pounds.
Clutch Nut -----	160 to 170 inch-pounds.
Connecting Rod Screws -----	65 to 70 inch-pounds.

ACCESSORIES

Part Number	Description
83434	Manual - Owner's
63746	Scrench
63341A	Kit - Spike
62827	Wrench
65712	Guide - Timing
63432	Spark Plug - AC CS42T
65778	Spark Plug - AC CS41T
69210	Piston Assy - 0.020 in. oversize
62813	. Ring Set - Piston 0.020 in. oversize
69211	Piston Assy - 0.030 in. oversize

Part Number	Description
62812	. Ring Set - Piston 0.030 in. oversize
64330	Bar Plate Set
63084	Manual - Shop
69058	Kit - Wrap around frame
69191	Kit - Pressure test adaptor
83406	Kit - Spark arrester screen
-84453	Kit - Piston tool
63541	Bar - 16 in.
62556M	Chain Assy - 16 in. bar

**40:1 TWO-CYCLE
MOTOR OIL**



6 oz. can # 78960
6-pack # 78961
16oz. can # 78963
6-pack # 78964
1qt. bottle # 110626

Reduces smoke,
carbon and engine wear.

**CHAIN, BAR AND
SPROCKET OIL**



1 qt. bottle # 110631
Case of 24 # 110632

Specially designed for
extra lubrication of bars
and chains.

BAR GUARDS

Protect bar and chain
from accidental
damage.

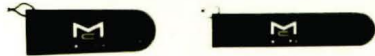

A **B**
Black Polyvinylchloride

(A) for wide bars #56927
(B) narrow bars #64930



C **D**
Rigid Yellow Plastic

(C) MAC 10-16, 20" #66544
(D) PM 6-12, 16" #83124

LOCQUIC AND

Primer. Cleans,
degreases, and
accelerates curing.

7-1/2 oz. spray can.
#69794



LOCTITE

Sealant, bonding
agent

10cc plastic
bottle
#67537



SPRAY PAINT

Black

12 oz. can #103503
Case of 12 #103400



Yellow

12 oz. can #102449
Case of 12 #102464

STARTER ROPE

Solid, braided nylon



100' spool
#36825

CHAIN SHARPENING TOOLS

The ● shows which tools are used on chains		S-25	SM-57	S-40	S-80	S-90
McCULLOCH FILES 	1/8" round	●				
	5/32" round	●	●			
	3/16" round		●			
	7/32" round			●		
	1/4" round				●	
	9/32" round					●
	8" flat	●	●	●	●	●
6" flat safety	●	●	●	●	●	
FILE GUIDE & FILE 						
	#67750 (1/8" round)	●				
	#60950 (7/32" round)			●		
	(Also holds 3/16 and 1/4" round)			●		
DEPTH GAUGE TOOLS 						
	#56241 .045-.060"			●	●	●
	#64198 .035-.060"		●	●	●	●
	#64359 .045-.050"		●			
	#67688 .015-.020"	●				
	#67680 .025-.030"	●	●	●	●	●
FILE-N-JOINT Assures correct filing angle, height. 						
	#61034	●	●	●	●	●

**"BREAK ALL"
CHAIN BREAKER**
Required when
repairing chain.

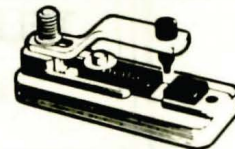

#61753
Instructions
included.

PRESSURE TEST TOOLS

For leakage check
of crankcase,
fuel system.



Basic unit
#62849



● MANUFACTURING ● SALES ● SERVICE ●

**McCULLOCH
CORPORATION**

P.O. Box 92180, Los Angeles, CA 90009

Copyright - McCulloch.

**FOR SERVICE-RELATED PROBLEMS,
REPAIR OR MAINTENANCE
TAKE YOUR UNIT TO THE NEAREST
AUTHORIZED McCULLOCH SERVICING
DEALER LISTED IN YOUR
TELEPHONE DIRECTORY YELLOW PAGES.**

If additional assistance is required, call this toll-free hot-line:
(800) 423-6302

Arizona residents call collect (602) 453-3681