

# ILLUSTRATED PARTS LIST

MODEL NAMES	SERIAL PREFIX NUMBER	MODELS
Pro Mac 700	11-	600116-02
Pro Mac 700	11-	600116-03
Pro Mac 700	11-	600116-04
Pro Mac 4300	11-	600116-05
Pro Mac 700	11-	600116-06

McCulloch products are identified by a model number (in this instance 600116 followed by a suffix number (05 or 06). Suffix numbers denote variations in parts or assemblies used in the manufacture of this product.

Illustrated Parts Lists (IPLs) contain a PART NUMBER, DESCRIPTION, UNITS per assembly and STOCKING CODE for each part. **Stocking Codes** are:

- A - Dealer stocked. Fast to medium moving part.
- B - Distributor stocked. Medium to slow moving part.
- C - Factory stocked. Slow moving part.
- T - Indicates a McCulloch service tool.
- N - No longer available.
- R - Replaced part.

**NOTE:** The following explains symbols/footnotes in this IPL.

(-) A dash preceding a PART NUMBER indicates that it is a new part number, different from the one listed in the previous IPL for this unit.

(. .) One or more dots (. Spring-Starter) preceding a part DESCRIPTION indicates the part is included in the kit or assembly described directly above the dot(s).

(- - -) If four dashes appear in place of a PART NUMBER, the part is not available individually but is included in the next higher assembly or subassembly.

① ② Circled numbers preceding a DESCRIPTION footnote the part or assembly to additional information on the page.

(\*) An asterisk draws attention to general information.

The policy of McCulloch Corporation is one of continual improvement in design, manufacturing and engineering advancement wherever possible to assure still finer power tools. Hence, specifications, equipment, colors, design and manufacturer's suggested list prices are subject to change without notice. McCulloch Corporation reserves the right to make such changes without prior notification or obligation to backfit or supply backfit components for units previously shipped from the factory.

## PRO MAC 4300 PRO MAC 700 CHAIN SAW



### CONTENTS

	PAGE
FIGURE 1 General Assembly . . . . .	2
FIGURE 2 Chain Brake Assembly . . . . .	4
FIGURE 3 Fan Housing / Starter Assembly . . . . .	5
FIGURE 4 Carburetor Assembly . . . . .	6
FIGURE 5 Fuel Tank Assembly . . . . .	7
FIGURE 6 Powerhead Assembly . . . . .	8
FIGURE 7 Specifications . . . . .	10
FIGURE 8 Tools and Accessories . . . . .	10
FIGURE 9 Bar /Chain /Chain Sharpening Tools . . . . .	11

JULY 1992



**McCULLOCH  
CORPORATION**

P.O. Box 11990 • Tucson, Arizona 85734

216176-02

© U.S.A. - McCulloch Corporation, 1992 • Printed in U.S.A.

# FIGURE 1 GENERAL ASSEMBLY

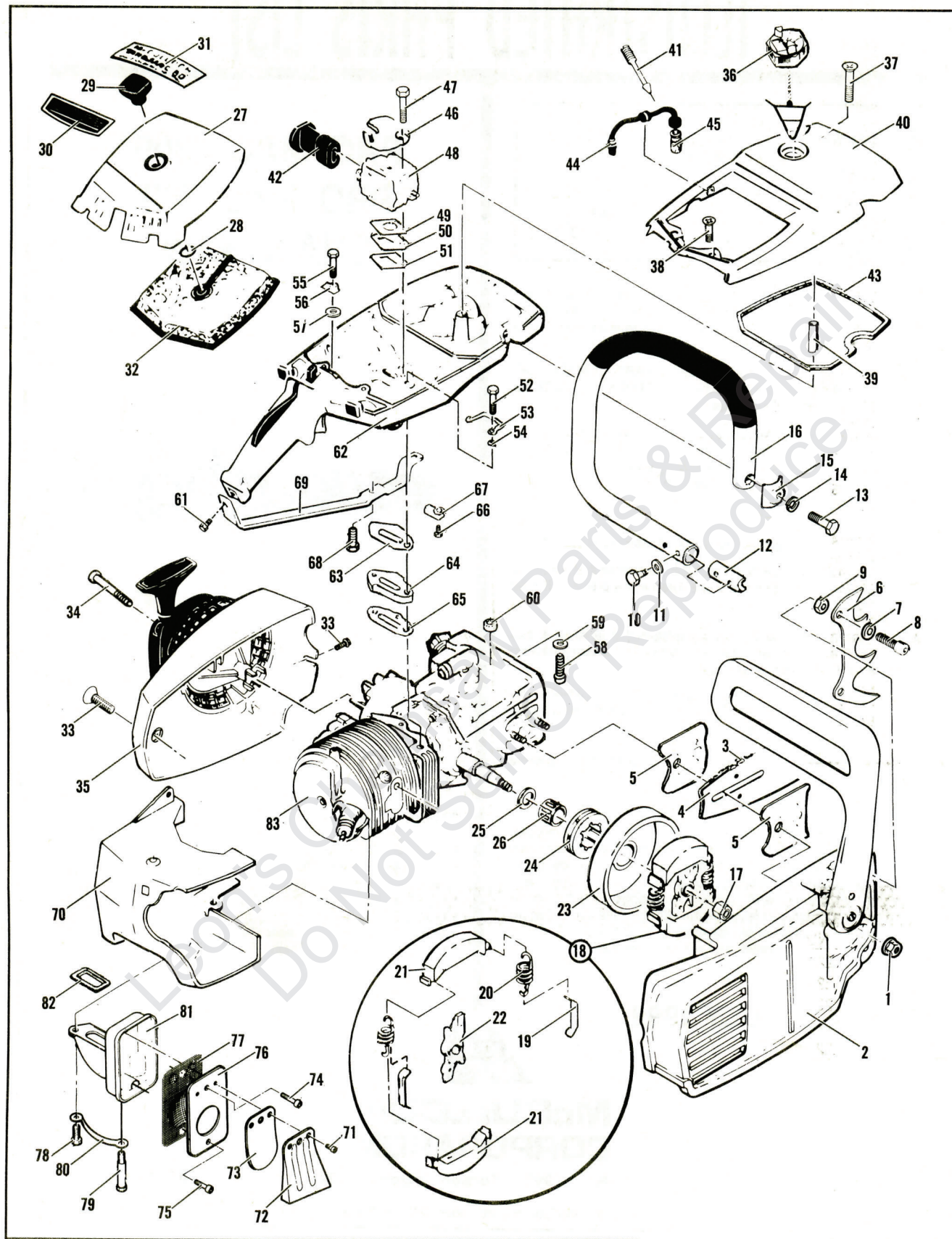

FIGURE 1 GENERAL ASSEMBLY

ITEM NO.	STK. CODE	PART NUMBER	DESCRIPTION	UNITS PER ASY.
1	A	216640	Nut-Flange 5/16-24	2
2		Fig. 2	Chain Brake	1
3		Fig. 9	Chain Assembly	1
4		Fig. 9	Bar Assembly	1
5	A	64325	Plate-Bar Guide	2
6	A	93668	Spike	1
7	A	216683	Washer-Spec. #10	2
8	A	213042	Screw-Skt 10-24x.62	2
9	A	216682	Nut-Hx Lock 10-24	2
10	A	216677	Screw-Hx 10-24x.875 SL	2
11	B	100352	Washer-#10 Plain	2
12	A	89727	Retainer-Frame	1
13	A	216638	Screw-Hx Hd 1/4-20x1.50	1
14	A	100153	Washer-Lock .250	1
15	A	216639	Clamp-Frame	1
16	A	214549	Frame & Grip Assembly	1
17	B	223060	Nut-Hx (L.H.)	1
18	A	214301	Clutch Assembly	1
19	A	64583	. Retainer-Spring	2
20	A	83223	. Spring-Clutch	2
21	B	67233	. Kit-Clutch Shoe	1
22	A	214300	. Rotor-Clutch	1
23	A	95165	Drum & Spkt Asy. 7T (.375)	1
24	C	86961	. Sprocket-7T (.375P)	1
25	A	86958	① . Washer-Shim	1
26	A	110971	① Bearing-Needle	1
27	B	91543	Cover Asy-Air Cleaner	1
28	B	110565	. Ring-Retaining	1
29	B	68529	. Knob-Cover	1
30		---	Plate-Name	1
31	B	216054	Label-Logo	1
32	A	216685	Filter-Air	1
33	A	110741	Screw-Pn Hd 10-24x.50	1
34	A	87871	Screw-Fan Housing	3
35		Fig. 3	Fan Housing/Starter Asy.	1
36	A	216053	Cap Asy-Fuel W/Retainer	1
37	A	216678	Screw-Oval Hd 12-24x2.375	1
38	C	101986	Screw-Oval Hd 10-24x1	2
39	C	87840	Spacer-Fuel Tank Cover	1
40	C	87677	Cover-Fuel Tank	1
41	B	87932	Screw-Idle Adjustment	1
42	B	87665	Boot-Carb. Adjust.	1

ITEM NO.	STK. CODE	PART NUMBER	DESCRIPTION	UNITS PER ASY.
43	A	69345	Gasket-Fuel Tank Cover	1
44	A	215708	Hose Asy-Fuel	1
45	A	215714	. Pickup Asy-Fuel	1
46	B	69952	Bracket-Air Cleaner	1
47	A	103357	Bolt-Hx Hd 10-24x2.25	2
48		Fig. 4	Carburetor Assembly	1
49	A	86189	Gasket-Carburetor	1
50	B	84078	Spacer-Carburetor	1
51	A	84081	Gasket-Carb Spacer	1
52	A	110567	Screw-Hx Hd 12-24x1.25	2
53	A	68582	Plate-Lock	1
54	A	102115	Washer-Plain .254x.033	2
55	A	110568	Screw-Hx Hd 12-24x1.12	1
56	A	69516	Plate-Lock	1
57	B	100352	Washer-#10 Plain	1
58	A	110713	Screw-Skt Hd 10-24x.88	1
59	A	100003	Washer-#10 Plain	1
60	A	69772	Spacer-Fuel Tank	1
61	A	216632	Screw-Pn Hd 10-24x1.25	1
62		Fig. 5	Fuel Tank Assembly	1
63	A	84082	Gasket-Fuel Tank	1
64	B	84080	Insulator-Fuel Tank	1
65	A	68594	Gasket-Fuel Tank	1
66	A	216679	Screw-Hx Hd 10-24x.625	1
67	A	68508	Plate-Lock	1
68	A	216679	Screw-Hx Hd 10-24x.625	1
69	B	85007	Brace-Frame	1
70	B	214702	Shroud-Cylinder	1
71	A	110563	Screw-Skt Hd 8-32x.25	2
72	A	92996-01	Stop-Reed	1
73	A	85585-01	Valve-Reed	1
74	A	101563	Screw-Skt Hd 10-24x1.25	1
75	A	110439	Screw-Skt Hd 10-24x1.00	1
76	A	92995	Cover-Spark Arrestor	1
77	A	92993	Baffle-Screen Arrestor	1
78	A	110529	Screw-Hx Hd 10-24x.50	1
79	A	68187	Screw-Hx 10-24x1.38	1
80	A	67922	Plate-Lock	1
81	A	92989	Body/Duct Asy. S/A	1
82	A	84007	Gasket-Muffler	1
83		Fig. 6	Powerhead Assembly	1

① Whenever Needle Bearing, P/N 110971, is used as a service replacement, Washer, P/N 86958, **MUST** be used. Both components are available by ordering Bearing Kit, P/N 215720 (CODE C).

### LOCTITE KIT

PART NUMBER	DESCRIPTION
322235	LOCTITE KIT
322236	. RETAINING COMPOUND 620 (10 ml)
322237	. THREAD LOCKER 242 (10 ml)
322238	. GASKET ELIMINATOR 518 (50 ml)
322239	. BLACK MAX ADHESIVE 380 (01 oz)

KIT INCLUDES: LOCTITE PRODUCT GUIDE, POCKET GUIDE AND MSDS DATA SHEETS

# FIGURE 2 CHAIN BRAKE ASSEMBLY

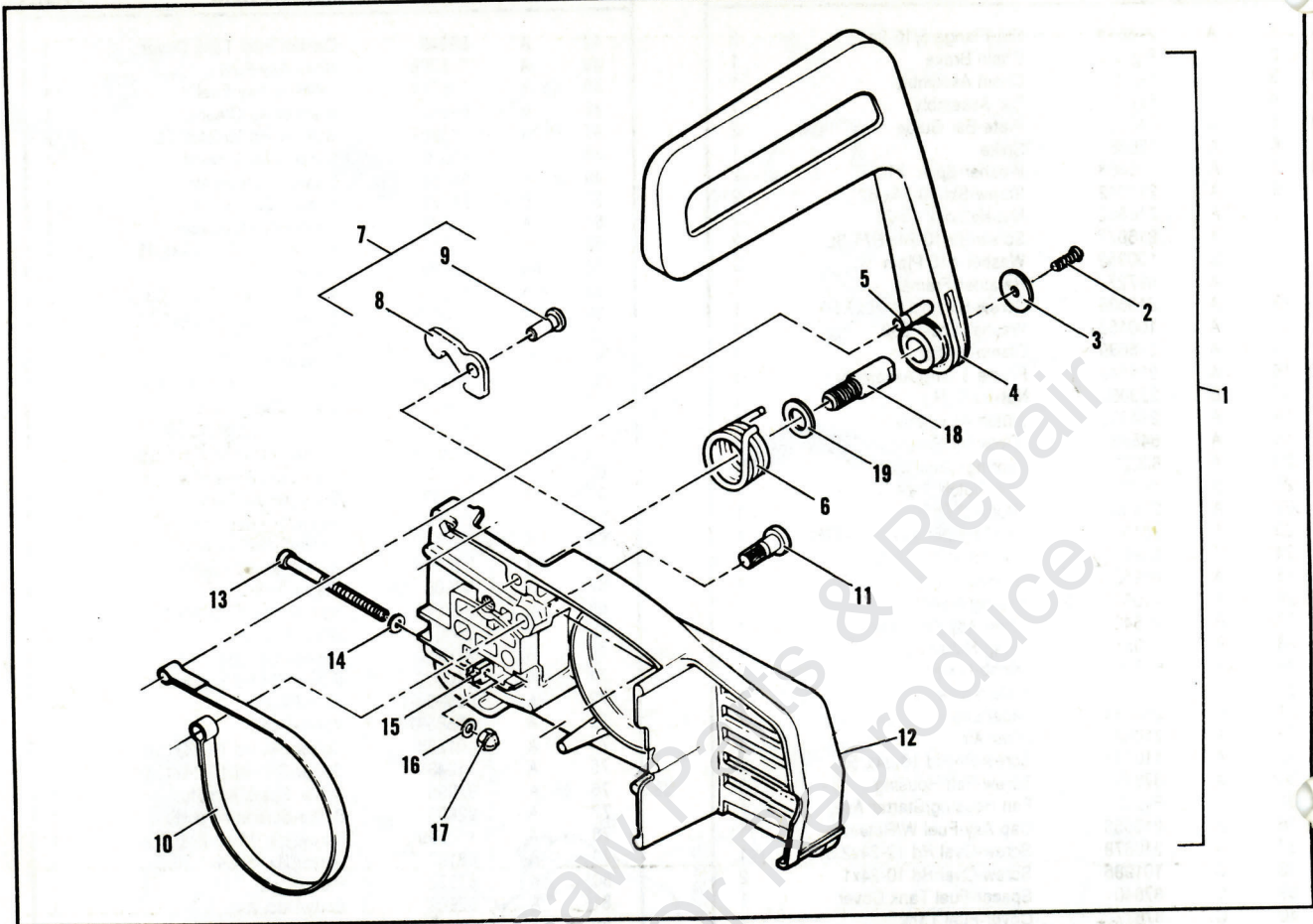

ITEM NO.	STK CODE	PART NUMBER	DESCRIPTION	UNITS PER ASY.
1	A	217694	Chain Brake Assembly	1
2	A	216634	Screw-Pn Hd 10-24x.50	1
3	B	216633	Washer-Plain .210 I.D.	1
4	B	215911	Lever Assembly	1
5	A	214366	Pin Asy-Roller	1
6	B	93085	Spring-Brake	1
7	A	222478	Kit Latch-Pivot	1
8	--	--	Latch	1
9	--	--	Pivot-Latch	1
10	A	93081	Band-Brake	1

ITEM NO.	STK CODE	PART NUMBER	DESCRIPTION	UNITS PER ASY.
11	B	93082	Pin-Band Anchor	1
12	--	--	Housing, Brake	1
13	A	216636	Screw-Fil 10-24x2.75	1
14	A	110582	Washer-#10	1
15	A	61705	Nut-Blade Adjust	1
16	A	100002	Washer-#10 Plain	1
17	A	102067	Nut-Hx Lock 10-24	1
18	B	91246	Pin-Lever Pivot	1
19	B	91245	Washer-Thrust	1

Ⓢ If replacement of either pivot or latch is necessary, you **MUST** order P/N 222478 (item 7) and replace both.

# FAN HOUSING / STARTER ASSEMBLY **FIGURE 3**

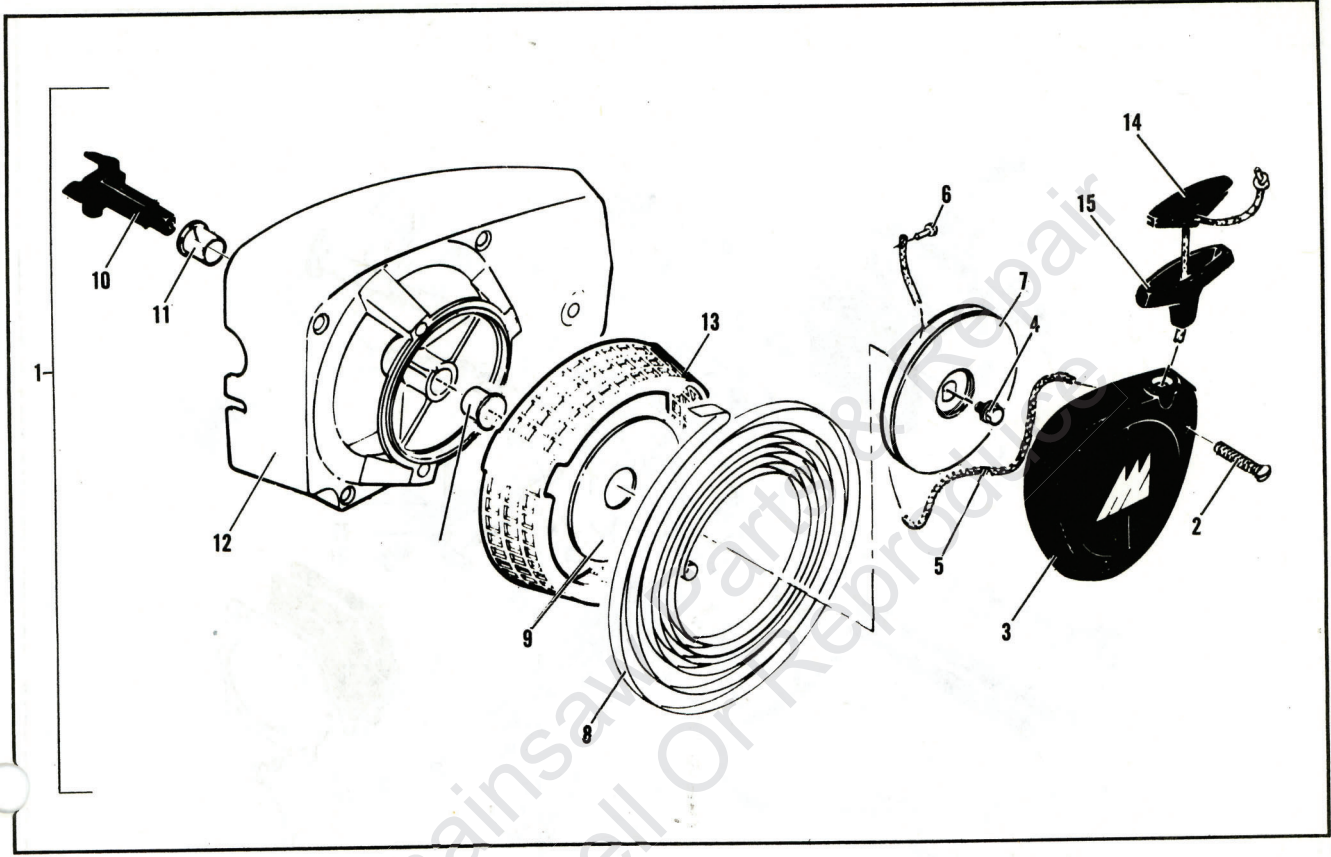

ITEM NO.	STK. CODE	PART NUMBER	DESCRIPTION	UNITS PER ASY.
1	B	216050	Fan Housing/Starter Asy	1
2	A	216623	Screw-Oval 8-32x1.12	3
3	B	91084	Cover-Starter	1
4	A	217935	Screw-Hx 10-24x.50 Tor.	1
5	A	68162	Rope-Starter	1
6	A	110470	Rivet-Rope	1
7	A	85122	Drum Assy-Starter	1
8	A	87680	Pkg., Spring-Starter Rewind	1

ITEM NO.	STK. CODE	PART NUMBER	DESCRIPTION	UNITS PER ASY.
9	A	86053	Shield-Starter Spring	1
10	B	83748	Shaft-Starter	1
11	A	57535	Bushing-Starter	2
12	B	223953	Kit Housing-Fan/Guard	1
13	A	214192	Guard-Sawdust	1
14	A	214699	Insert-Handle	1
15	A	93137	Handle-Starter	1

ER  
SY.  
1  
1  
1  
1  
1  
1  
1  
1  
1

er P/N

# FIGURE 4 CARBURETOR ASSEMBLY

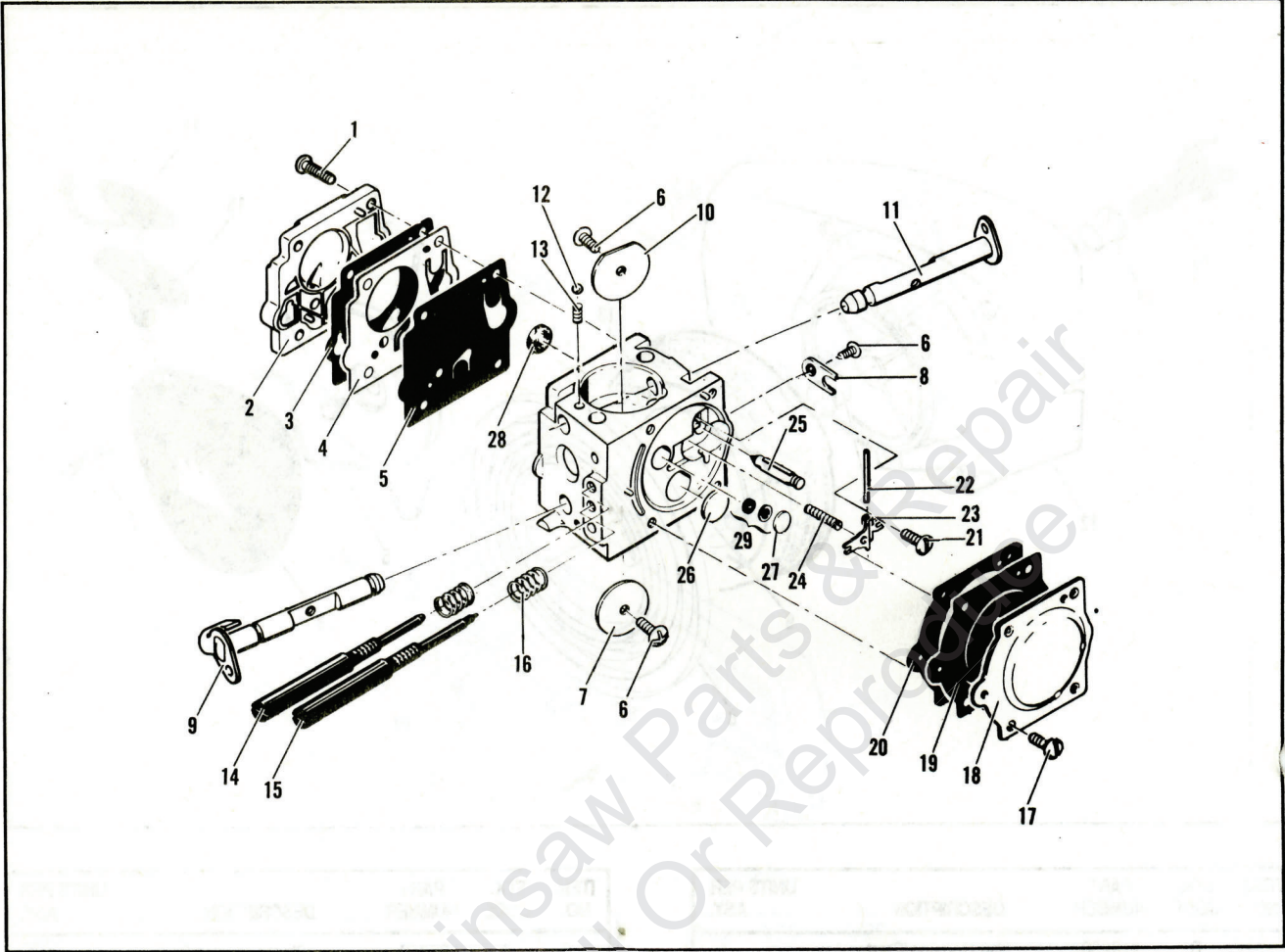

ITEM NO.	STK CODE	PART NUMBER	DESCRIPTION	UNITS PER ASY.
1	A	87666	Carburetor Asy. (SDC 44)	1
2	--	--	Screw-Pump Cover	1
3	--	--	Cover-Pump	4
4	--	--	①② Gasket-Cover	1
5	--	--	①② Diaphragm-Check Valve	1
6	--	--	①② Diaphragm-Fuel Pump	1
7	--	--	Screw-Plate	3
8	--	--	Plate-Throttle	1
9	--	--	Clip-Shaft	1
10	--	--	Shaft Asy-Throttle	1
11	--	--	Plate-Choke	1
12	--	--	Shaft Asy-Choke	1
13	--	--	Ball-Choke Friction	1
14	--	--	Spring-Choke	1
15	--	--	① Needle-High Speed	1

ITEM NO.	STK CODE	PART NUMBER	DESCRIPTION	UNITS PER ASY.
15	--	--	① Needle-Idle	1
16	--	--	Spring-Needle	2
17	--	--	Screw-Diaphragm Cover	4
18	--	--	Cover-Diaphragm	1
19	--	--	①② Diaphragm-Metering	1
20	--	--	①② Gasket-Diaphragm	1
21	--	--	① Screw-Lever Pin	1
22	--	--	① Pin-Lever	1
23	--	--	① Lever-Metering	1
24	--	--	① Spring-Lever	1
25	--	--	① Valve-Needle	1
26	--	--	① Plug 3/8	1
27	--	--	① Plug 5/16	1
28	--	--	① Screen-Fuel	1
29	--	83758	Kit, Valve & Seat Asy.	1

NOTE: Carburetor parts are shown for identification and disassembly sequence purposes only. Components are not available separately unless a part number is listed before the part description.

- ① Contained in Major Repair Kit, P/N 217080 (CODE A)
- ② Contained in Gasket/Diaphragm Kit, P/N 216738 (CODE C)

# FUEL TANK ASSEMBLY **FIGURE 5**

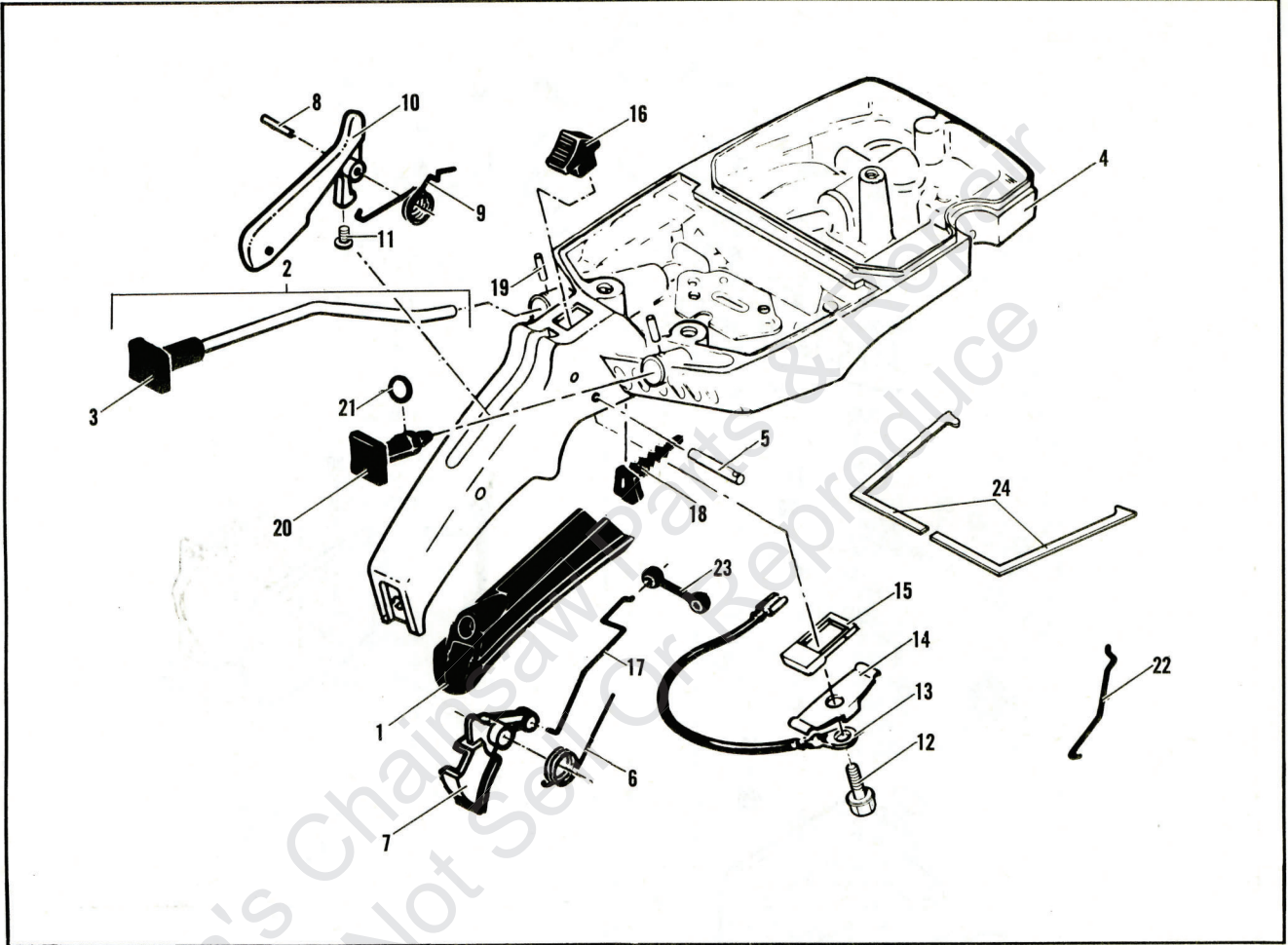

ITEM NO.	STK. CODE	PART NUMBER	DESCRIPTION	UNITS PER ASY.
1	A	89320	Insert-Handle Grip	1
2	B	216126	Button & Rod Assembly	1
3	B	95615	Button-Oiler	1
4	B	216127	Tank Asy-Fuel	1
5	C	110378	Pin-Roll .196x.937	1
6	A	92152	Spring-Trigger	1
7	A	214679	Trigger-Throttle	1
8	C	105654	Pin-Roll .131x.875	1
9	B	92154	Spring-Trigger Release	1
10	B	94275	Release Asy-Trigger	1
11	B	111012	Screw-Pn 4-40x.31 ST	1
12	A	110706	Screw-Pn 8-18x.50 ST	1

ITEM NO.	STK. CODE	PART NUMBER	DESCRIPTION	UNITS PER ASY.
13	A	214692	Wire Asy-Switch	1
14	B	62451	Contact-Ign. Switch	1
15	B	214691	Base-Stop Switch	1
16	A	68846	Button-Stop Switch	1
17	B	85107	Rod-Throttle	1
18	B	214701	Seal-Throttle Rod	1
19	B	105673	Pin-Roll .099x.562	2
20	B	69041	Button-Choke	1
21	A	105614	"O" Ring .239x.070	1
22	C	69042	Rod-Choke	1
23	A	69043	Snubber	1
24	A	219280	Kit, Gasket (L.H. & R.H.)	1

# FIGURE 6 POWERHEAD ASSEMBLY

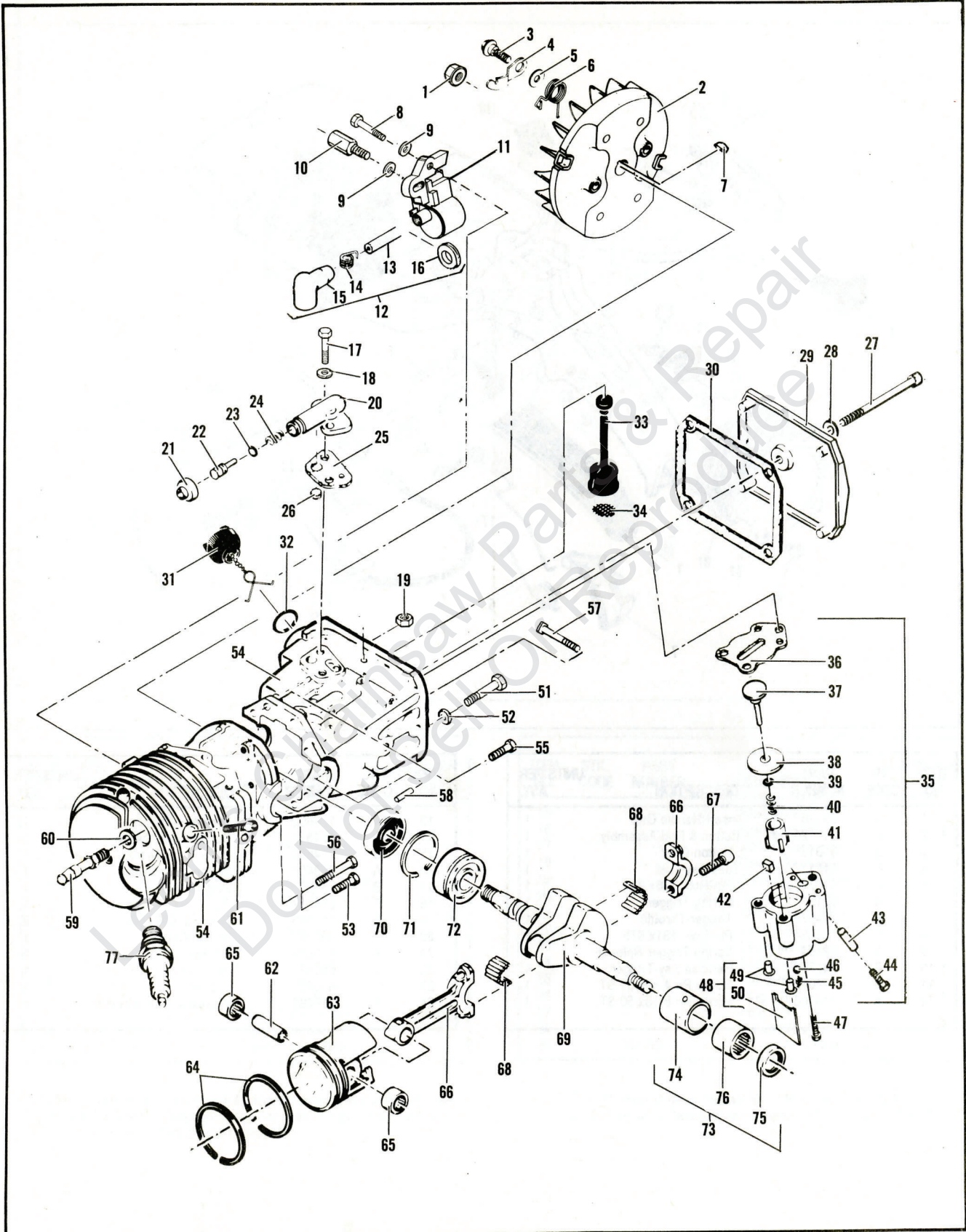



FIGURE 6 POWERHEAD ASSEMBLY

ITEM NO.	STK. CODE	PART NUMBER	DESCRIPTION	UNITS PER ASY.
1	B	110703	Nut-Hx 3/8-24	1
2	A	216739	Flywheel Assembly	1
3	B	93464	. Screw-Pawl Pivot	2
4	A	93198	. Pawl-Starter	2
5	B	93469	. Washer-Starter Pawl	2
6	A	214102	. Spring-Starter Pawl	2
7	A	100106	Key-Woodruff	1
8	A	110127	Screw-Hx 10-24x.88 Sems	1
9	C	223637	Spacer, .21Dx.44Dx.12	2
10	B	83512	Stud-Special	1
11	A	223708	Kit, Ignition Assembly	1
12	A	223884	. Kit, Spark Plug Wire	1
13	B	---	.. Wire-7mm Ignition	1
14	A	102556	.. Connector, Spark Plug	1
15	A	95266	.. Boot, Spark Plug	1
16	B	110995	.. Grommet, Spark Plug Wire	1
	B	215533-01 ①	.. Grommet, H/T Lead	1
17	B	110338	Screw-Hx 8-32x.532	2
18	B	110613	Washer-#8 Hard	2
19	B	100955	Nut-Hx Lock 8-32	1
20	A	84156	Housing-Oil Pump	1
21	A	215151	Cap-Oil Pump	1
22	B	62266	Plunger-Oil Pump	1
23	A	105614	*O* Ring .239x.070	1
24	B	66687	Spring-Plunger	1
25	A	91669	Gasket-Oil Pump Hsg.	1
26	A	91668	Valve-Oiler	1
27	B	110291	Screw-Pn 10-24x2.62	1
28	C	110921	Washer-Sealing	1
29	B	218707	Cover-Oil Tank	1
30	A	86306	Gasket-Cover Oil Tank	1
31	A	216052	Cap Asy-Oil	1
32	A	101148	.O-Ring .75 IDx.09	1
33	A	91672	Hose Asy-Oil Pickup	1
34	B	51506	. Screen-Oil Intake	1
35	A	215339	Kit-Pump Tested	1
36	B	92874	. Seal-Pulse Pump	1
37	A	214278	. Piston Asy-Oiler	1
38	B	86182	. Ring-Piston Pulse Oiler	1

ITEM NO.	STK. CODE	PART NUMBER	DESCRIPTION	UNITS PER ASY.
39	A	105603	. O-Ring .114x.070	1
40	A	60259	. Spring-Piston	1
41	C	62227	. Sleeve-Adjustment	1
42	B	91259	. Pad-Pump	1
43	C	91774	. Sleeve-Pulse Pump Body	1
44	A	217936	. Screw-Hx 10-24x.875 SL	1
45	--	--	. Spring-Outlet Valve	1
46	--	--	. Ball	1
47	C	110963	Screw-Hx 8-32x1.00 WSH	1
48	A	215246	Kit, Oil Pump Retainer	1
49	--	--	. Eyelets	2
50	--	--	. Clip-Sealing	1
51	A	62106	Screw-Wsh 12-24x1.75	4
52	A	111025	Washer-Sealing Alum.	4
53	A	110288	Screw-Hx 8-32x.75	1
54	A	214671	Cylinder/C'Case Asy.	1
55	A	110288	. Screw-Hx 8-32x.75	2
56	A	110618	. Screw-Hx 8-32x1.37 Wsh	1
57	A	62065	. Bolt-Bar Mounting	2
58	C	110851	. Pin-Dowel	1
59	A	94273	Valve-Comp. Release	1
60	A	214765	Washer-Valve	1
61	B	110681	Screw-Skt 10-24x.25	1
62	A	69020	Pin-Piston	1
63	A	85239	Piston Assembly	1
64	A	89732	. Set-Piston Ring	1
65	A	111021	. Bearing-Needle	2
66	A	85352	Rod Assembly-Connecting	1
67	A	61627-01	. Screw-Connecting Rod	2
68	A	63225	. Roller-Needle(Set of 20)	1
69	A	216909	Crankshaft Assembly	1
70	A	61618	. Seal-Oil	1
71	B	63464	. Ring-Snap	1
72	A	63429-02	. Bearing-Ball	1
73	A	87151	Insert-Bearing Asy Needle	1
74	--	--	. Insert-Bearing	1
75	A	110260	. Seal-Oil	1
76	A	104357	. Bearing-Needle	1
77	A	62345	Spark Plug	1

① Not illustrated. Included in Kit, Spark Plug Wire, P/N 223884 which is a universal kit. Please discard Grommet, H/T Lead and use Grommet, Spark Plug Wire, P/N 110995 for installation on Pro Mac 4300 and Pro Mac 700.

## FIGURE 7 SPECIFICATIONS

Bar Length .....	16-28 in.
Weight .....	15.6 lbs.
Displacement .....	4.3 cu in.
Bore and Stroke .....	2.000 in. x 1.375 in.
Cylinder Type .....	Hard Chrome
Ignition .....	Electronic
Ignition Timing .....	26 degrees B.T.D.C.
Lamination Gap .....	.011-.015 (30-40 mm)
Spark Plug Gap .....	.025 in. (.63 mm)
Sprocket Type .....	7T .375 Pitch, Floating Rim
Clutch Engagement Speed .....	2800-3000 rpm
Oil Tank Capacity .....	9.6 oz.
Fuel Tank Capacity .....	24.0 oz.

### TORQUE VALUES

Connecting Rod Screws .....	65-75 in. lbs.
Clutch Nut .....	160-170 in. lbs.
Flywheel Nut .....	265-325 in. lbs.

## FIGURE 8 TOOLS AND ACCESSORIES

PART NUMBER	STOCK CODE	DESCRIPTION
94121-01	A	Universal Carrying Case
92896	C	Guard - Bar 16 in.
86419	T	Timing Guide
69191	T	Kit, Pressure Test Adapter
215432	T	Tool, Pressure Test
63139	T	Adapter Plate, Intake
63137	T	Adapter Plate, Exhaust
84453	T	Kit, Piston Tool
214221	A	Scrench
214223	A	Spark Plug, Standard Type
63432	B	Spark Plug, Cooler Type
91226	T	Wrench, Clutch/Flywheel
322235	T	Kit, LOCTITE

# BAR / CHAIN / SHARPENING TOOLS FIGURE 9

Bar Description	Bar Part Number	Replacement Nose Description	Replacement Nose Part Number
16" Mac 10 .375	89502	*	---- ---- ----
16" Speed Mac .375	94074	Nose Assembly Bar .375	86830
16" Speed Mac .375	94074-05	Kit Sprocket Nose Asy	219807
16" Speed Mac .325	223195	.325 Pitch Nose Asy	223183
20" Mac 10 .375	89503	*	---- ---- ----
20" Speed Mac .375	93778	Nose Assembly Bar .375	86830
20" Speed Mac .375	93778-05	Kit Sprocket Nose Asy	219807
20" Speed Mac .325	218924	.325 Pitch Nose Asy	218999
24" Mac 10 .375	89504	*	---- ---- ----
24" Speed Mac.375	86846	Nose Assembly Bar .375	86830
24" Speed Mac.375	86846-05	Kit Sprocket Nose Asy	219807
28" Mac 10 .375	89505	*	---- ---- ----
28" Speed Mac .375	86847	Nose Assembly Bar .375	86830
28" Speed Mac .375	86847-05	Kit Sprocket Nose Asy	219807
33" Speed Mac .375	91284-00	Kit Sprocket Nose Asy	86830
33" Speed Mac .375	91284-01	Kit Sprocket Nose Asy	219807

\* Replacement nose assemblies are not available for these bars.

The **Mac 10** series bar features a stellite hard facing material welded to the nose to increase bar life. These bars are recommended for use in tough or abrasive conditions.

The **Speed Mac** series features a solid steel body, with heat treated, hardened bar rails for maximum strength and durability. This bar also features a removable sprocket nose that can be replaced when worn or damaged. This Bar is ideal for use where conditions demand long continual use.

Chain Description	Chain Part Number	File Plate Part Number	File Part Number	File Size
16" PMR 370 GLX 60 CL	218839-12	219132	219161	7/32
16" PM 370 GX 60 CL	88167-12			
16" SPR 370 GX 60 CL	89974-12	219130	98023	11/64
16" SPG 320 GLX 68 CL	218551-12			
20" SPR 370 GX 70 CL	89978-12	219132	219161	7/32
20" SPR GX 71 CL	89979-12			
20" PM 370 GX 71 CL	88173-12			
20" PMR 370 GLX 71 CL	218069-12	219130	98023	11/64
20" SPG 320 GLX 79 CL	218552-12			
24" SPR 370 GX 81 CL	89981-12	219232	219161	7/32
24" PM 370 GX 81 CL	88175-12			
24" PMR 370 GLX 81 CL	218070-12			
24" SPR 370 GX 82 CL	89982-12			
24" PM 370 GX 82 CL	93551-12			
28" SPR 370 GX 92 CL	89984-12			
28" PM 370 GX 93 CL	93552-12	92101-12	92101-12	92101-12
33" SPR 370 GX 106 CL	92101-12			

**NOTE:**

Chains identified by the letters **GLX** feature a low kickback design and are recommended for the casual user or home owner.

Chains identified with the letters **GX** are recommended for the experienced chainsaw user or the professional.

For more information on chains, bars, and accessories, refer to accessories catalog P/N 180119-R1.



• MANUFACTURING • SALES • SERVICE •

P.O. Box 11990 • Tucson, AZ 85734

**IF ADDITIONAL ASSISTANCE IS  
REQUIRED, CALL THIS TOLL-  
FREE HOT-LINE MON. - FRI.  
6:00 AM - 4:45 PM (MST)**

**1-800-423-6302**

ARIZONA RESIDENTS CALL:

**1-800-221-6507**

Leon's Chairs Saw Repair  
Do Not Sell or Reproduce