

Models	Serial Number Prefix
600036A	11-, 12
600036B	11-, 12
600036C	11-
600036D	11-, 12
600036J	11-, 12

PRO MAC 60 CHAIN SAW

ILLUSTRATED PARTS LIST

Pro Mac 60 chain saws are identified by a model number (600036) followed by a suffix letter (A, B, C, etc.) stamped on the identification plate attached to the saw. Suffix letters denote variations in parts or assemblies in manufacture of the saw.

Part numbers listed in this I.P.L. which have a suffix letter or letters following the description, indicate the part is used only on the model identified by that letter or letters.

Part numbers and descriptions without suffix letter or letters apply to all models of the Pro Mac 60 saw.

I.P.L. 89321 supersedes and cancels
I.P.L. 87717

The policy of McCulloch Corporation is one of continual improvement in design, manufacturing and engineering advancement wherever possible to assure still finer two-cycle power tools. Hence, specifications, equipment, colors, design and manufacturer's suggested list prices are subject to change without notice and McCulloch Corporation reserves the right to make such changes without prior notification or obligation to backfit or supply backfit components for units previously shipped from the factory.

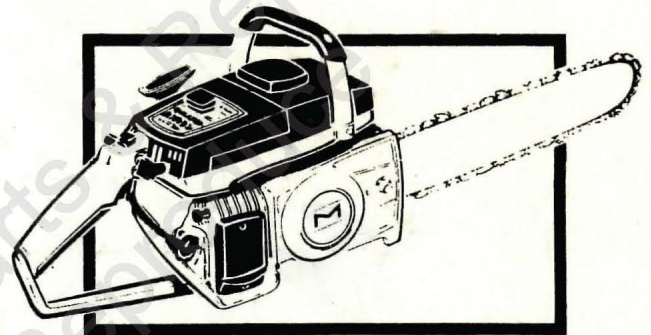

JULY 1973

	Page
Figure 1. General.....	2
Figure 2. Fan Housing & Starter Assemblies	4
Figure 3. Fuel Tank Assembly	4
Figure 4. Carburetor Assembly ...	6
Figure 5. Carburetor Assembly ...	6
Figure 6. Powerhead Assembly....	8
Figure 7. Bar & Chain Assembly ..	10

 **McCULLOCH**

COPYRIGHT U.S.A. 1973
McCULLOCH CORPORATION
Printed in U.S.A.

89321

PRO MAC 60

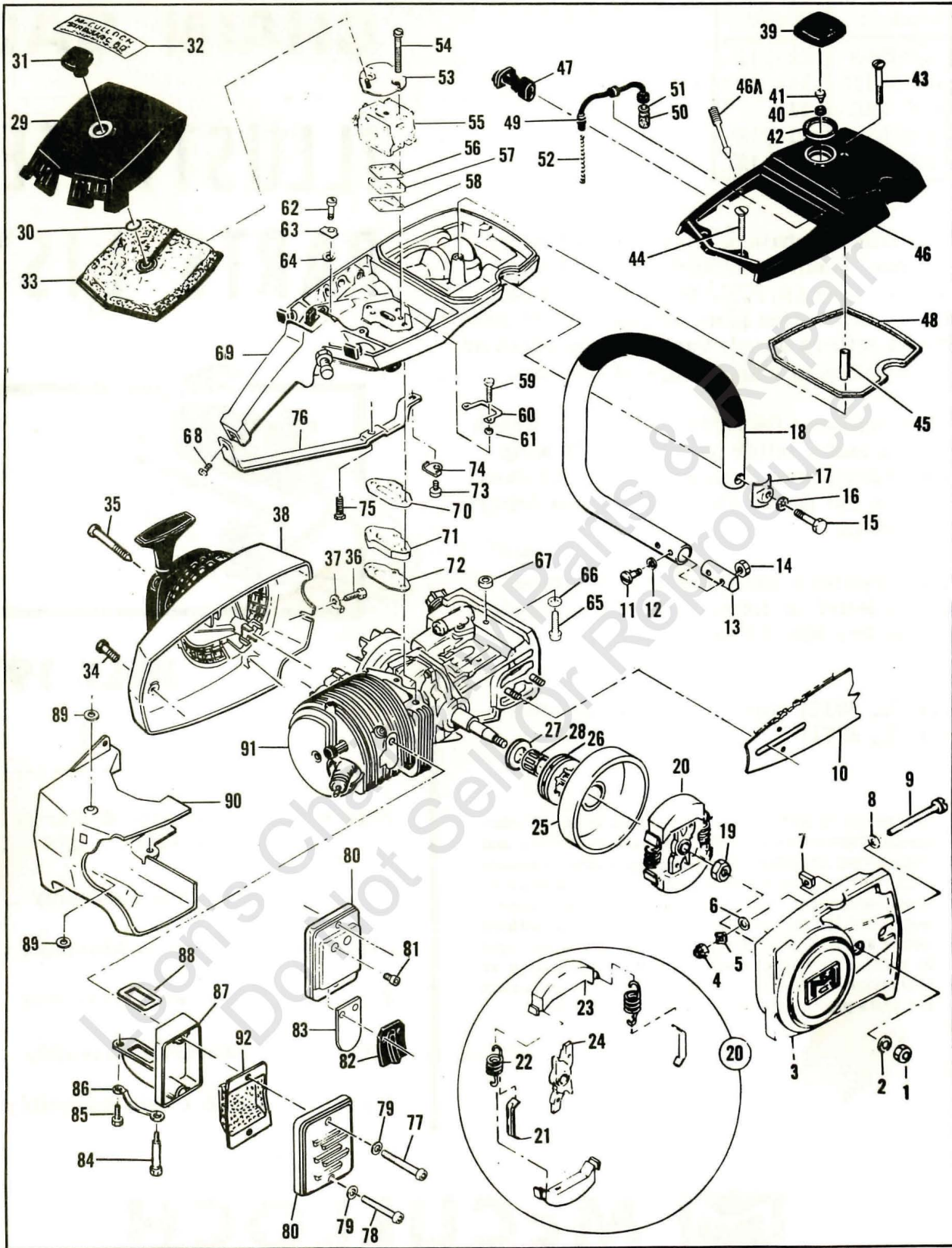

Figure 1. General

FIGURE 1. GENERAL

Item No.	Part Number	Description	Units Per Assy
1	110454	Nut - Hex 5/16-24	2
2	100440	Washer - 5/16	2
3	84530	Clutch Guard Assy	1
4	102067	. Nut - Hex 10-24	1
5	110387	. Washer - Wavey	1
6	100002	. Washer - #10	1
7	61705	. Nut - Bar adjustment	1
8	110264	. Washer - #10	1
9	102144	. Screw - Bar adjustment	1
10		Bar & Chain Assy (See Figure 7)	
11	102761	Screw - Hex hd 10-24 x 7/8	2
12	100352	Washer - #10	2
13	61678	Plug - Nut retainer	1
14	101326	Nut - Hex 10-24	2
15	102130	Screw - Hex hd 1/4-20 x 1-1/2	1
16	100153	Lockwasher - 1/4	1
17	63484	Clamp - Frame	1
18	87686	Frame & Grip Assy	1
19	86113	Nut - Hex 3/8-24 (L. H.)	1
20	87675	Clutch Assy	1
21	64583	. Retainer - Spring	2
22	83223	. Spring - Clutch	2
23	67233	. Shoe - Clutch	2
24	87673	. Rotor Assy	1
	86946	Kit - Sprocket & Drum (B, C, D, J)	1
	-86942	Kit - Sprocket & Drum (A)	1
25	86948	. Drum - Clutch (B, C, D, J)	1
	-86947	. Drum - Clutch (A)	1
26	86951	. Sprocket - 7T .375 (B, C, D, J)	1
	86344	. Sprocket - 7T .375 (A)	1
27	86958	. Washer	1
28	110330	Bearing - Sprocket	1
29	68530	Cover Assy - Air cleaner	1
30	110565	. Ring - Retainer	1
31	68529	. Knob - Cover	1
32	87718	Nameplate	1
33	69922	Filter - Air	1
34	110741	Screw - Pan hd 10-24 x 1/2	1
35	62978	Screw - Special	3
36	102762	Screw - Hex hd 10-24 x 1/2	1
37	69890	Lockplate	1
38		Fan Housing & Starter (See Figure 2)	
39	86451	Cap Assy - Fuel	1
40	86453	. Plug	1
41	53766A	. Valve	1
42	69767	. Gasket	1
43	110402	Screw - Oval hd 12-24 x 2-3/8	1
44	103579	Screw - Fl hd 10-24 x 1	2
45	87840	Spacer	1
46	①-88650	Cover - Fuel tank	1
	②-89323	Cover - Fuel tank	1
46A	① 87932	Screw - Idle adjustment	1
47	① 87665	Boot - Carburetor	1

Item No.	Part Number	Description	Units Per Assy
48	69345	Gasket - Cover	1
49	64848	Hose Assy - Fuel	1
50	63932	. Filter - Fuel	1
51	100440	. Washer	1
52	67944	Spring - Hose	1
53	83204	Bracket Assy	1
54	103357	. Screw - Hex hd 10-24 x 2-1/4	2
55		Carburetor Assy (See Figure 4)	
56	86189	Gasket - Carburetor	1
57	84078	Spacer - Carburetor	1
58	84081	Gasket - Spacer	1
59	110567	Screw - Hex hd 12-24 x 1-1/4	2
60	68582	Lockplate	1
61	102115	Washer - #2	2
62	110568	Screw - Hex hd 12-24 x 1-1/8	1
63	69516	Lockplate	1
64	64856	Washer - Special	1
65	110713	Screw - Skt hd 10-24 x 7/8	1
66	100003	Washer - #10	1
67	69772	Spacer - Fuel tank	1
68	① 106078	Screw - Pan hd 10-24 x 7/16	1
	②-104816	Screw - Pan hd 10-24 x 1-1/4	1
69		Fuel Tank Assy (See Figure 3)	
70	84082	Gasket - Fuel tank	1
71	84080	Insulator - Fuel tank	1
72	68594	Gasket - Insulator	1
73	110566	Screw - Hex hd 12-24 x 5/8	1
74	68508	Lockplate	1
75	110682	Screw - Hex hd 10-24 x 5/8	1
76	85007	Brace - Handle	1
77	104534	Screw - Skt hd 10-24 x 1-7/16	1
78	101563	Screw - Skt hd 10-24 x 1-1/4	1
79	24236	Washer - Special	2
80	① 83966	Cover - Muffler (A, C, D)	1
	②-88779	Cover - Muffler (A, D)	1
	② 87683	Cover - Valve Assy (A, B, J)	1
81	110472	. Screw - Skt hd 8-32 x 5/16 (B, J)	2
82	87286	. Stop - Reed (B, J)	1
83	87682	. Valve - Reed (B, J)	1
84	68187	Screw - Special	1
85	110529	Screw - Hex hd 10-24 x 1/2	1
86	67922	Lockplate	1
87	87663	Body & Duct Assy	1
88	84007	Gasket - Muffler	1
89	68581	Insulator - Shroud	2
90	85731	Shroud	1
91		Powerhead Assy (See Figure 5)	
92	② 85152	Baffle (A, B, J)	1

① Models with serial numbers prefixed 11-.

② Models with serial numbers prefixed 12-.

PRO MAC 60

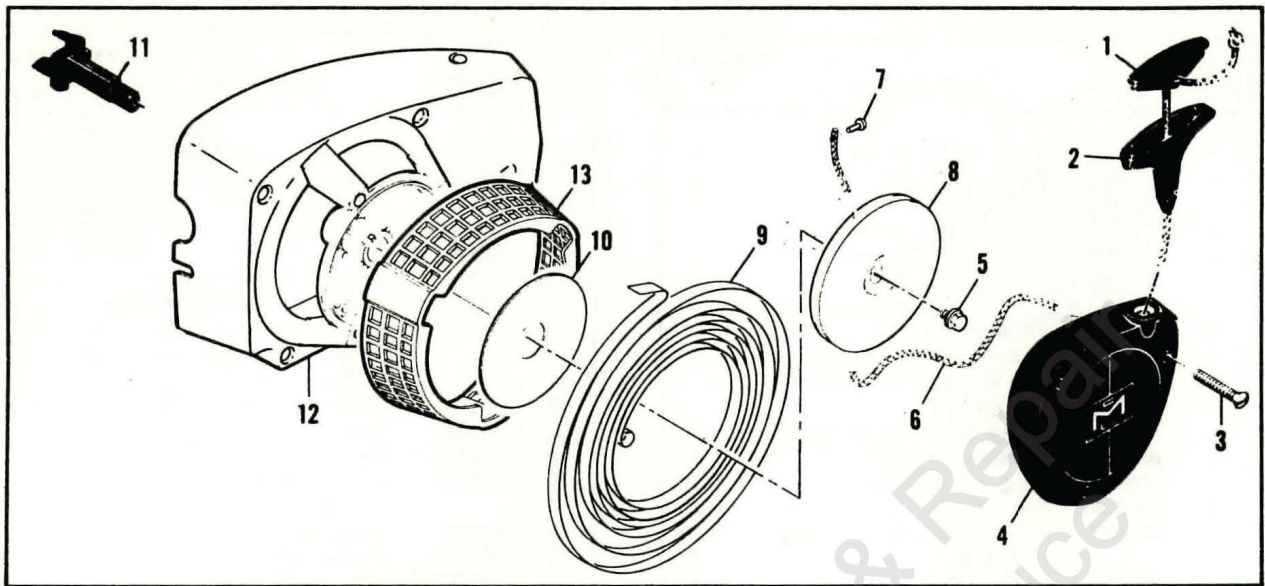

Figure 2. Fan housing & Starter Assemblies

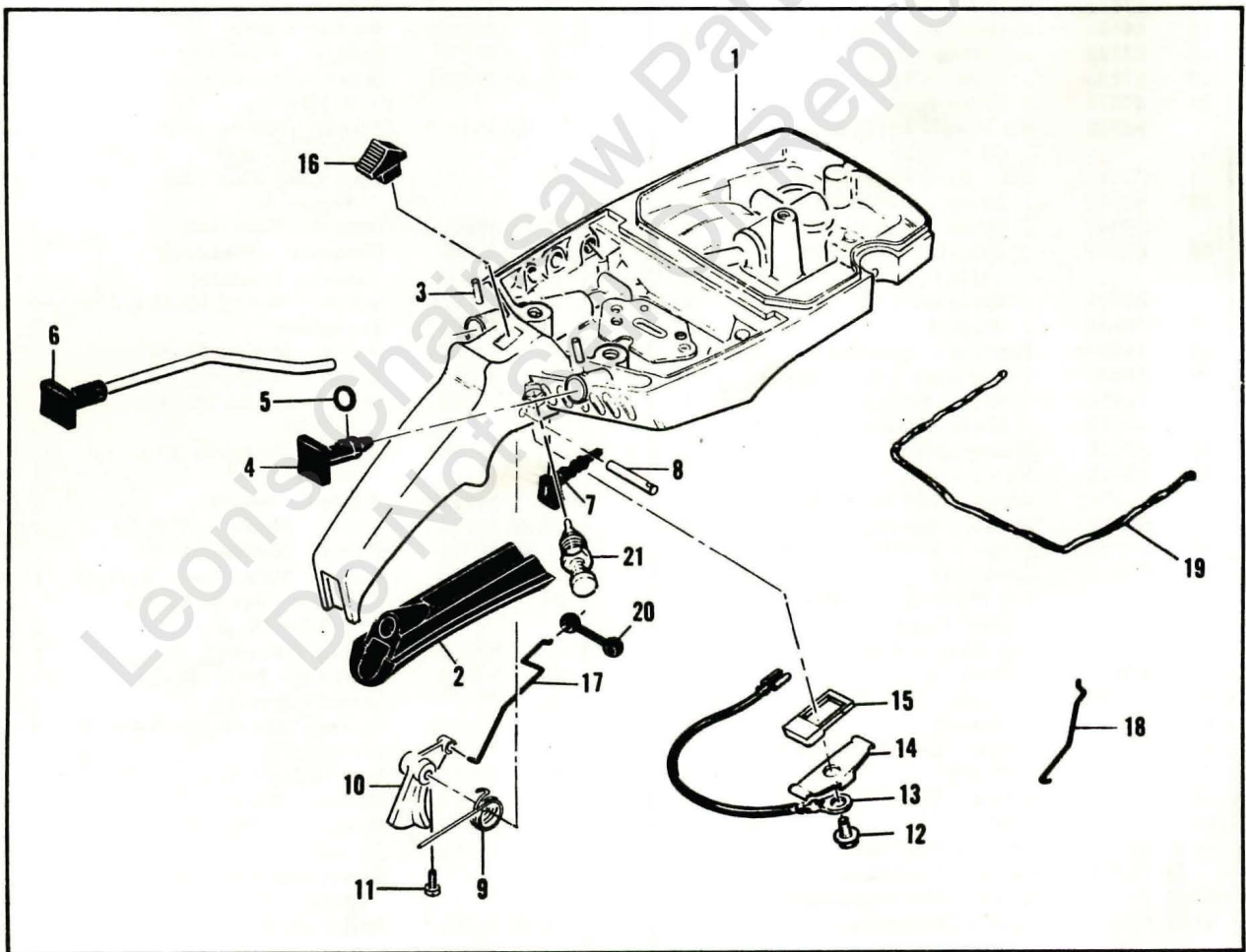

Figure 3. Fuel Tank Assembly

FIGURE 2. FAN HOUSING & STARTER ASSEMBLIES

Item No.	Part Number	Description	Units Per Assy
1	62191A	Insert - Starter handle	1
2	62190A	Handle - Starter	1
3	110646	Screw - Oval hd 8-32 x 1-1/8	3
4	87672	Cover - Starter	1
5	110341	Screw - Hex hd 10-24 x 1/2	1
6	68162	Rope - Starter	1

Item No.	Part Number	Description	Units Per Assy
7	110470	Rivet	1
8	-85122	Drum - Starter	1
9	87680	Spring - Rewind	1
10	86053	Shield - Spring	1
11	83748	Shaft - Starter	1
12	87693	Kit - Fan housing	1
13	87674	. Guard - Sawdust	1

FIGURE 3. FUEL TANK ASSEMBLY

Item No.	Part Number	Description	Units Per Assy
1	87685	Fuel Tank	1
2	① 87883	Grip - Handle	1
	②-89400	Grip - Handle	1
3	105673	Pin - Roll 3/32 x 9/16	2
4	69041	Button - Choke	1
5	101056	"O" Ring	1
6	64871	Button & Rod Assy	1
7	68522	Seal - Throttle rod	1
8	110378	Pin - Roll 3/16 x 15/16	1
9	87178	Spring - Throttle return	1
10	86450	Trigger	1
11	110668	Screw - Fil hd 8-36 x 5/8	1

Item No.	Part Number	Description	Units Per Assy
12	103672	Screw - Fil hd 8-32 x 1/2	1
13	62973A	Wire Assy - Stop switch	1
14	62451	Contact - Switch	1
15	62950A	Base - Switch	1
16	68846	Button - Switch	1
17	85107	Rod - Throttle	1
18	69042	Rod - Choke	1
19	*69564	Seal - Airbox	1
20	69043	Snubber - Rod	1
21	85451	Latch Assy - Throttle	1

*Furnished on a 12-1/2 in. strip containing 9 beads (enough for 9 replacements)

- ① Models with serial numbers prefixed 11-.
- ② Models with serial numbers prefixed 12-.

Part numbers which have changed since the previous printing of the illustrated parts list covering these saws, are indicated by a dash (-) preceding the new part number.

PRO MAC 60

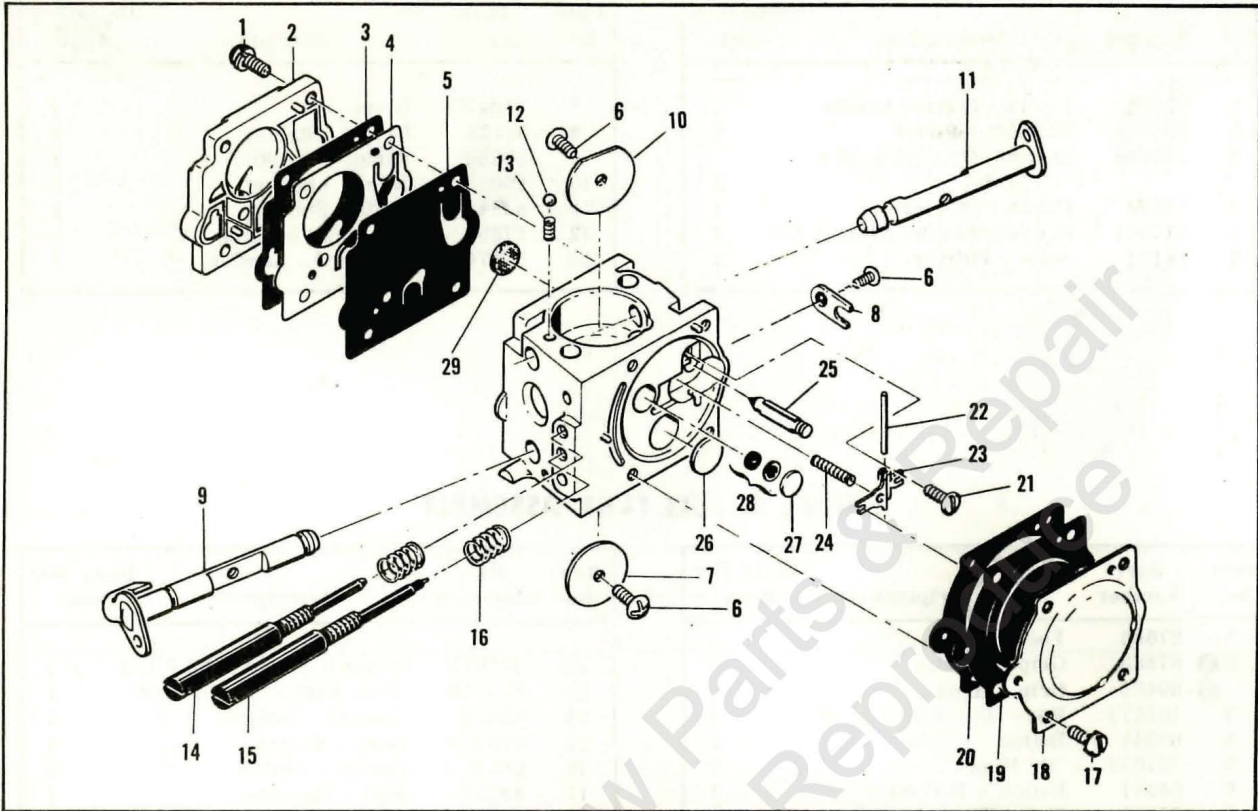

Figure 4. Carburetor Assembly

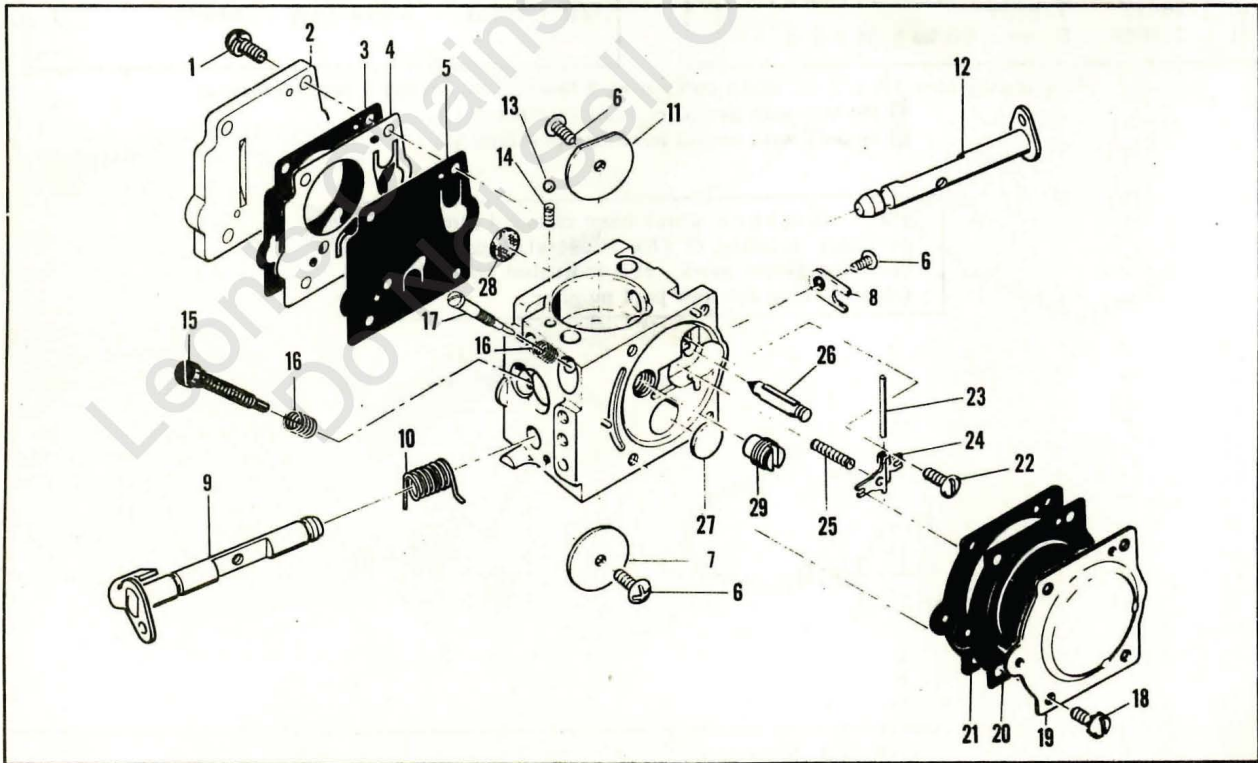

Figure 5. Carburetor Assembly

FIGURE 4. CARBURETOR ASSEMBLY

Item No.	Part Number	Description	Units Per Assy
	87666	Carburetor Assy	1
1	67501	. Screw - Pump cover	4
2	83760	. Cover - Pump	1
3	67495	. Gasket - Cover	1
4	67498	. Diaphragm - Check valve	1
5	83114	. Diaphragm - Fuel pump	1
6	47690	. Screw - Plate	3
7	83762	. Plate - Throttle	1
8	67489	. Clip - Shaft	1
9	67486	. Shaft Assy - Throttle	1
10	67490	. Plate - Choke	1
11	67488	. Shaft Assy - Choke	1
12	100302	. Ball - Choke friction	1
13	67504	. Spring - Choke	1
14	87915	. Needle - High speed	1

Item No.	Part Number	Description	Units Per Assy
15	87916	. Needle - Idle	1
16	67502	. Spring - Needle	2
17	70798	. Screw - Diaphragm cover	4
18	83761	. Cover - Diaphragm	1
19	67499	. Diaphragm - Metering	1
20	67496	. Gasket - Diaphragm	1
21	67500	. Screw - Lever pin	1
22	67508	. Pin - Lever	1
23	67509	. Lever - Metering	1
24	67503	. Spring - Lever	1
25	67491	. Valve - Needle	1
26	71690	. Plug - 3/8	1
27	69506	. Plug - 5/16	1
28	83758	. Kit - Valve & Seat Assy	1
29	67507	. Screen - Fuel	1

FIGURE 5. CARBURETOR ASSEMBLY

Item No.	Part Number	Description	Units Per Assy
	- 89324	Carburetor Assy	1
1	67501	. Screw - Pump cover	4
2	88731	. Kit - Pump cover	1
3	**88617	. . Gasket - Cover	1
4	*67498	. Diaphragm - Check valve	1
5	*83114	. Diaphragm - Fuel pump	1
6	*47690	. Screw - Plate	3
7	83762	. Plate - Throttle	1
8	67489	. Clip - Shaft	1
9	67486	. Shaft Assy - Throttle	1
10	85981	. Spring - Throttle return	1
11	67490	. Plate - Choke	1
12	67488	. Shaft Assy - Choke	1
13	*100302	. Ball - Choke friction	1
14	*67504	. Spring - Choke friction	1
15	*68106	. Screw - Idle speed	1
16	*67502	. Spring - Idle	2
17	90345	. Needle - Idle mixture	1
18	70798	. Screw - Diaphragm cover	4

Item No.	Part Number	Description	Units Per Assy
19	83761	. Cover - Diaphragm	1
20	*67499	. Diaphragm - Metering	1
21	**67496	. Gasket - Diaphragm	1
22	*67500	. Screw - Lever pin	1
23	*67508	. Pin - Lever	1
24	*67509	. Lever - Inlet	1
25	*67503	. Spring - Lever	1
26	*67491	. Valve - Needle	1
27	*71690	. Plug - 3/8	1
28	*67507	. Screen - Fuel	1
29	90346	. Jet - High speed (.032")	1
	90347	Jet - High speed (.033")	Alt.
	90348	Jet - High speed (.031")	Alt.
	90349	Jet - High speed (.0292")	Alt.
	90350	Jet - High speed (.028")	Alt.
	90351	Jet - High speed (.026")	Alt.
	*88619	Kit - Gasket	
	88620	Kit - Repair	

** Contained in Gasket Kit 88619
 * Contained in Repair Kit 88620

PRO MAC 60

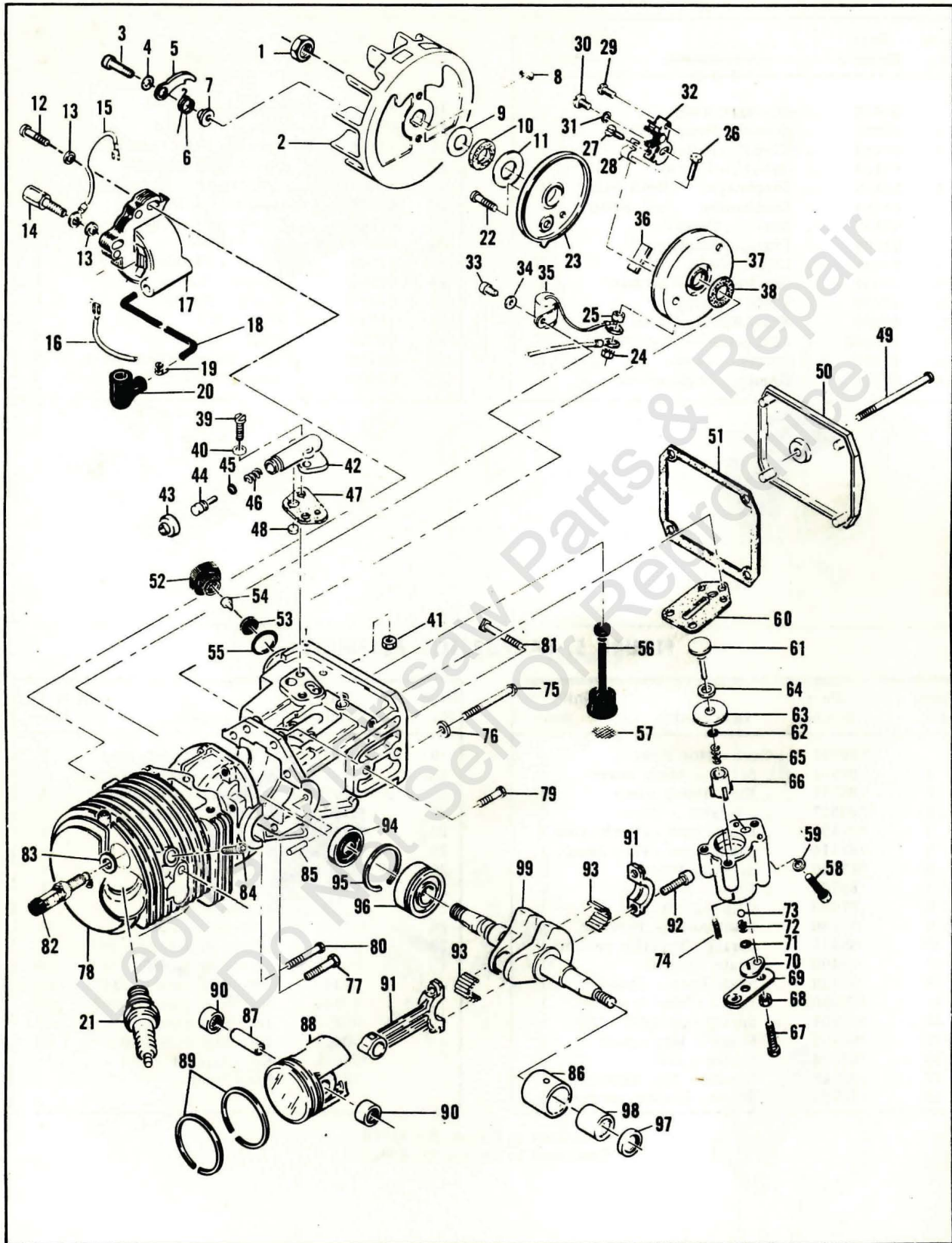

Figure 6. Powerhead Assembly

FIGURE 6. POWERHEAD ASSEMBLY

Item No.	Part Number	Description	Units Per Assy
1	110703	Nut - Hex 3/8-24	1
2	86068	Flywheel	1
3	110713	Screw - Skt hd 10-24 x 7/8	2
4	83241	Washer - Special	2
5	67546	Pawl - Starter	2
6	67545	Spring - Pawl	2
7	67547	Pivot - Pawl	2
8	103879	Key - Woodruff	1
9	67057	Washer - Thrust	1
10	67056	Seal - Breaker box cover	1
11	67054	Washer - Thrust	1
12	110127	Screw - Hex hd 10-24 x 7/8 (SEMS)	1
13	100002	Washer - #10	2
14	83512	Stud - Special	1
15	84686	Wire Assy - Ground	1
16	69344	Wire Assy - Primary	1
17	87246	Coil & Lamination Assy	1
18	50120	Wire Assy - Spark plug	1
19	55061	Connector	1
20	85758	Boot	1
21	63432	Spark Plug - AC CS 42T (B, C, D, J)	1
	65408	Spark Plug - Ch CJ8 (A)	1
22	110584	Screw - Pan hd 8-32 x 3/4	1
23	62362	Cover - Breaker box	1
24	100298	Nut - Hex 6-32	1
25	62365	Spacer - Breaker	1
26	110346	Screw - Hex hd 6-32 x 3/4	1
27	110706	Screw - Pan hd 8-18 x 1/2	1
28	83126	Strap - Conduction	1
29	110811	Screw - Pan hd 8-32 x 3/8	1
30	110445	Screw - Truss hd 8-32 x 3/8	1
31	105976	Washer - #8	1
32	66231	Breaker Assy	1
33	103672	Screw - Fil hd 8-32 x 1/2 (SEMS)	1
34	100080	Washer - #8	1
35	85358	Condenser	1
36	54184	Wiper - Cam	1
37	84329	Box - Breaker	1
38	67051	Seal - Breaker box	1
39	-103672	Screw - Fil hd 8-32 x 1/2 (SEMS)	2
40	105976	Washer - #8	2
41	100955	Nut - Hex 8-32	1
42	84156	Housing - Pump	1
43	62262	Cap - Housing	1
44	62266	Plunger - Pump	1
45	101056	"O" Ring	1
46	66687	Spring - Pump	1
47	62230	Gasket - Pump	1
48	62909	Valve - Pump	1
49	110291	Screw - Pan hd 10-24 x 2-5/8	1

Item No.	Part Number	Description	Units Per Assy
50	86304	Cover - Oil tank	1
51	86306	Gasket - Cover	1
52	87270	Cap - Oil tank	1
53	87269	Retainer - Valve	1
54	86402	Valve - Check	1
55	101148	"O" Ring	1
56	62123B	Hose Assy - Oil	1
57	51506	Screen - Hose	1
58	110713	Screw - Skt hd 10-24 x 7/8	1
59	24236	Washer - Special	1
60	86188	Gasket - Pulse pump	1
	-89115	Pump Assy - Pulse	1
61	60260A	Piston Assy - Pump	1
62	104001	"O" Ring	1
63	86182	Ring - Piston	1
64	60937	Washer - Teflon	1
65	60259	Spring - Piston	1
66	62227	Sleeve - Adjustment	1
67	110386	Screw - Hex hd 8-32 x 1	1
68	100251	Nut - Hex 8-32	1
69	-89114	Clamp - Pump	1
70	62407	Cover - Outlet valve	1
71	106104	"O" Ring	1
72	62885A	Spring - Outlet valve	1
73	102809	Ball	1
74	110643	Screw - Set	1
75	62105	Screw Assy - Sealing	4
76	62842	Washer - Sealing	4
77	110288	Screw Assy - Hex 8-32 x 3/4	1
78	87715	Crankcase Assy	1
79	110288	Screw Assy - Hex 8-32 x 1-3/8	2
80	110618	Screw Assy - Hex 8-32 x 1-3/8	1
81	62065	Bolt - Bar mounting	2
82	84785	Valve - Comp. rel.	1
83	85505	Washer - Valve	1
84	110681	Screw - Skt hd 10-24 x 1/4	1
85	110851	Pin - Dowel	1
86	87152	Insert - Bearing	1
87	87710	Pin - Piston	1
88	87713	Piston Assy	1
89	87716	Ring Set - Piston	1
90	110590	Bearing - Needle	2
91	85352	Connecting Rod Assy	1
92	61627A	Screw - Skt hd special	2
93	63225	Roller - Needle (Set of 20)	1
94	61618	Seal - Oil	1
95	63464	Ring - Snap	1
96	63429B	Bearing - Ball	1
97	110260	Seal - Oil	1
98	104357	Bearing - Needle	1
99	87728	Crankshaft	1

① Models with serial numbers prefixed 11-.

PRO MAC 60

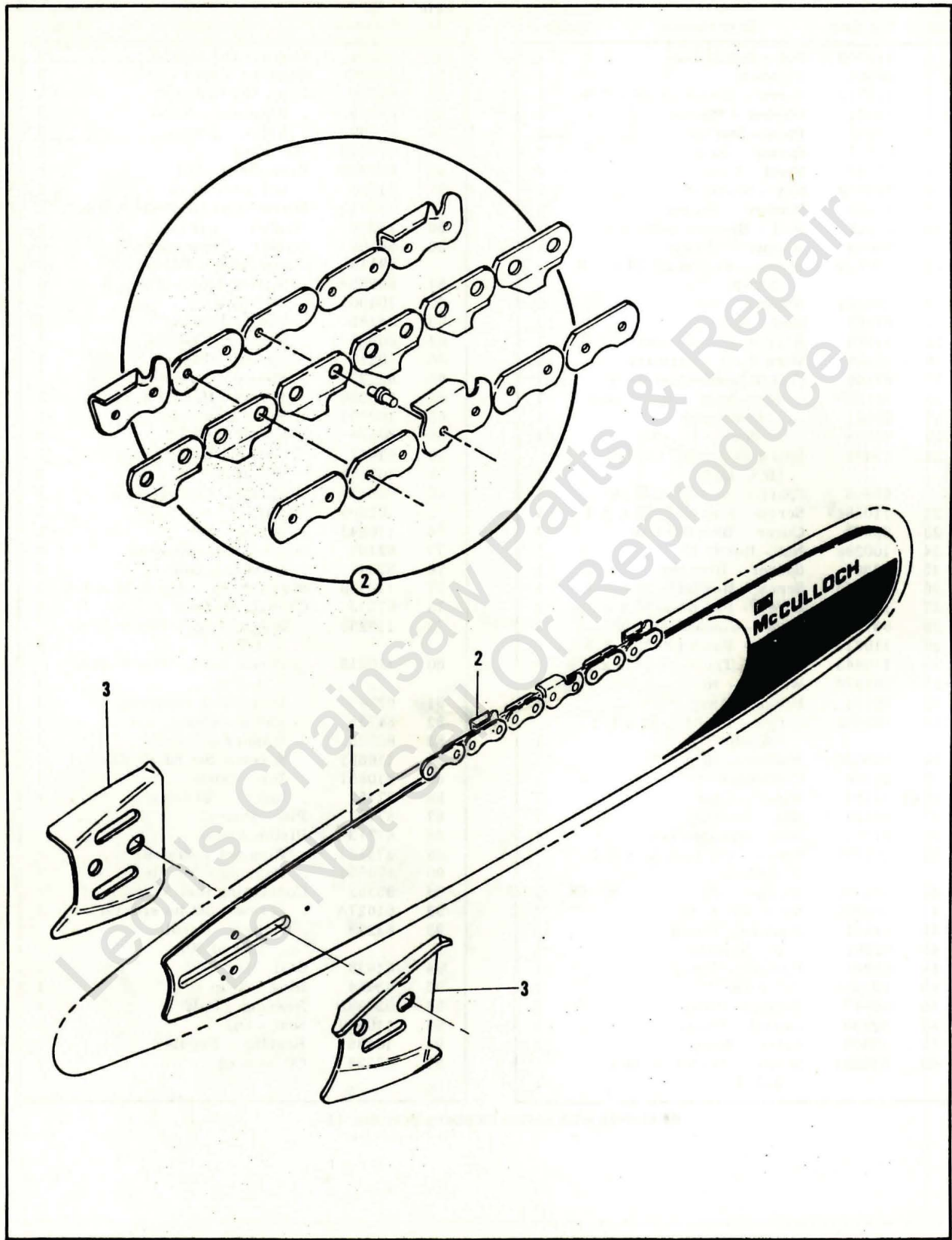

Figure 7. Bar & Chain Assembly

FIGURE 7. BAR & CHAIN ASSEMBLY

Item No.	Part Number	Description	Units Per Assy
1		Bar	1
2		Chain Assy	1

Item No.	Part Number	Description	Units Per Assy
3	64325	Plate - Bar	2

ACCESSORIES

Part Number	Description
84453	Kit - Piston tool
69191	Kit - Pressure test adaptor
63341A	Kit - Spike
84922	Kit - Baffle
86419	Guide - Timing
63097	Spark Plug - AC CS 45T (B, C, D, J)

Part Number	Description
65778	Spark Plug - AC CS 41T (B, C, D, J)
65409	Spark Plug - Ch CJ6 (A)
65551	Spark Plug - Ch CJ4 (A)
62827	Wrench (A, C, D, J)
83235	Wrench (B)
85726	Manual - Owners (A, C, D)

SERVICE SPECIFICATIONS

Spark Plug - AC CS 42T (Standard)
AC CS 41T (colder)
Spark Plug Gap - .025 inch (.63 mm)
Lamination Gap - .007 to .012 inch (.18 to .30 mm)
Breaker Point Gap - .018 inch (.46 mm)
Timing - 26° BTDC
Carburetor Adjustment
Idle mixture needle - 1 turn open (preliminary)
Main mixture - Fixed high speed jet
0 to 4000 feet - Jet No. 32
3000 to 5500 feet - Jet No. 31
4500 to 8000 feet - Jet No. 29
7000 feet and above - Jet No. 28
Clutch Engagement Speed - 2400 to 2800 R.P.M.
Torques
Connecting Rod Screws - 65 to 70 inch/pounds (74.88 to 80.64 cm/kg)
Clutch Nut - 160 to 170 inch/pounds (184.32 to 195.84 cm/kg)
Flywheel Nut - 265 to 325 inch/pounds (305.28 to 374.40 cm/kg)

PRO MAC 60 NUMERICAL ORDER PARTS LIST

Part Number	Description	Units Per Assy
24236	Washer - Special	2
47690	Screw - Rd 6-32	3
47690	Screw - Rd 6-32	3
50120	Wire Assy - Spark	1
51506	Screen - Oil	1
53766A	Valve	1
54184	Wiper - Oil wick	1
55061	Connector	1
60259	Spring - Piston	1
60260A	Piston Assy - Oiler	1
60937	Washer - Pulse pump	1
61618	Seal - Oil	1
61627A	Screw - Connecting rod	2
61678	Plug - Nut retaining	1
61705	Nut - Blade adjusting	1
62065	Bolt - Bar mounting	2
62105	Screw Assy - Sealing	4
62123B	Hose Assy - Oil	1
62190A	Handle - Starter	1
62191A	Insert - Starter	1
62227	Sleeve - Oiler	1
62230	Gasket - Oil pump	1
62262	Cap - Oil pump	1
62266	Plunger - Oil	1
62362	Cover - Breaker box	1
62365	Spacer - Breaker	1
62407	Cover - Outlet	1
62451	Contact - Ignition	1
62827	Wrench & Screwdriver	1
62842	Washer - Sealing	1
62885A	Spring - Outlet	1
62909	Valve - Oiler	1
62950A	Base - Stop switch	1
62973A	Wire Assy - Stop	1
62978	Screw - Oval 8-32	3
63097	Sparkplug	1
63225	Set - Needle	1
63341A	Kit - Spike	1
63429B	Bearing - Ball	1
63432	Sparkplug	1
63464	Ring - Snap	1
63484	Clamp - Frame	1
63932	Filter - Felt	1
64325	Plate - Bar guide	2
64583	Retainer - Clutch	2
64848	Hose Assy	1
64856	Washer - Plain	1
64871	Button & Rod Assy	1
65778	Sparkplug	1
66687	Spring - Plunger	1
67051	Seal - Breaker box	1
67054	Washer - Thrust	1
67056	Seal - Breaker box	1
67057	Washer - Thrust	1
67233	Shoe - Clutch	2
67486	Shaft Assy - Throttle	1
67488	Shaft Assy - Choke	1
67489	Clip - Throttle	1
67490	Valve - Choke	1
67491	Valve - Inlet needle	1

Part Number	Description	Units Per Assy
67495	Gasket - Fuel pump	1
67496	Gasket - Metering	1
67498	Diaphragm - Check	1
67499	Diaphragm Assy	1
67500	Screw - Metering lever	1
67501	Screw Assy	4
67502	Spring - Adjusting	2
67503	Spring - Lever	1
67504	Spring - Choke	1
67507	Screen - Inlet	1
67508	Pin - Metering	1
67509	Lever - Metering	1
67545	Spring - Pawl	2
67546	Pawl - Starter	2
67547	Pivot - Pawl	2
67922	Plate - Lock	1
67944	Spring - Hose	1
68106	Screw - Idle adjustment	1
68162	Rope - Starter	1
68187	Screw - Hex 10-24	1
68508	Plate - Lock	1
68522	Seal - Throttle	1
68529	Knob Assy	1
68530	Cover Assy - Air	1
68581	Insulator - Shroud	2
68582	Plate - Lock	1
68594	Gasket - Fuel tank	1
68846	Button - Stop	1
69041	Button - Choke	1
69042	Rod - Choke	1
69043	Snubber	1
69191	Kit - Adaptor	1
69344	Wire Assy - Primary	1
69345	Gasket - Fuel tank	1
69506	Plug - Welch	1
69516	Plate - Lock	1
69564	Seal - Air box	1
69767	Gasket - Fuel cap	1
69772	Spacer - Fuel tank	1
69890	Plate - Lock	1
69922	Filter - Air cleaner	1
70798	Screw Assy - Diaphragm	4
71690	Plug - Welch	1
83114	Diaphragm	1
83126	Strap - Conduction	1
83204	Kit - Air cleaner	1
83223	Spring - Clutch	2
83235	Wrench	1
83241	Washer - Starter	2
83512	Stud - Special	1
83748	Shaft Assy - Start	1
83758	Kit - Repair	1
83760	Cover - Fuel pump	1
83761	Cover - Metering	1
83762	Valve - Throttle	1
83966	Cover - Preheater	1
84007	Gasket - Muffler	1
84078	Spacer - Carburetor	1
84080	Insulator - Fuel tank	1
84081	Gasket - Carburetor	1
84082	Gasket - Fuel tank	1

Pro Mac 60 Numerical Order Parts List (Continued)

Part Number	Description	Units Per Assy
84156	Housing - Oil pump	1
84183	Kit - Fuel tank	1
84329	Box - Breaker	1
84453	Kit - Piston tool	1
84686	Wire Assy - Ground	1
84922	Kit - Baffle	1
85007	Brace - Frame	1
85107	Rod - Throttle	1
85122	Drum - Starter	1
85152	Baffle - Spark	1
85352	Rod Assy - Connecting	1
85358	Condenser	1
85451	Lock Assy - Throttle	1
85505	Washer - Valve	1
85726	Manual - Owners	1
85731	Shroud - Cylinder	1
85758	Boot - Sparkplug	1
85981	Spring - Throttle	1
86053	Shield - Starter	1
86068	Flywheel	1
86113	Nut - Left hand	1
86182	Ring - Piston	1
86189	Gasket - Carburetor	1
86304	Cover - Oil tank	1
86306	Gasket - Cover	1
86344	Kit - Sprocket 7T	1
86402	Valve - Check	1
86419	Guide - Timing	1
86450	Trigger - Throttle	1
86451	Cap Assy - Fuel	1
86453	Plug - Fuel cap	1
86942	Drum & Sprocket 7T	1
86946	Drum & Sprocket 7T	1
86947	Drum & Hub Assy	1
86948	Drum & Hub Assy	1
86951	Kit - Sprocket 7T	1
86958	Washer - Shim	1
87152	Insert - Bearing	1
87178	Spring - Trigger	1
87246	Coil & Lamination Assy	1
87269	Retainer - Valve	1
87270	Cap Assy - Oil	1
87286	Stop - Reed valve	1
87663	Body & Duct Assy	1
87665	Boot - Carburetor adj.	1
87666	Carburetor Assy	1
87672	Cover - Starter	1
87674	Guard - Sawdust	1
87675	Clutch Assy	1
87676	Rotor - Clutch	1
87680	Spring - Rewind	1
87682	Valve - Reed	1
87683	Cover & Valve Assy	1
87686	Frame & Grip Assy	1
87693	Kit - Fan housing	1
87710	Pin - Piston	1
87713	Piston Assy	1
87715	Cylinder & Crankcase	1
87716	Set - Piston ring	1
87718	Plate - Name	1
87728	Crankshaft	1
87840	Spacer - Fuel tank	1

Part Number	Description	Units Per Assy
87866	Valve - Compression rel.	1
87883	Grip - Handle	1
87915	Needle - Hi speed	1
87916	Needle - Idle	1
87932	Screw - Idle adjustment	1
88586	Guard Assy - Clutch	1
88617	Gasket - Fuel pump	1
88645	Screw - Oiler	1
88650	Cover - Fuel tank	1
88731	Kit - Fuel pump cover	1
88782	Gasket - Pulse pump	1
88808	Breaker Assy	1
89324	Carburetor	1
100002	Washer - #10	2
100003	Washer - Plain	2
100080	Washer - #8	1
100153	Washer - Lock 1/4	1
100251	Nut - Hex 8-32	1
100298	Nut - Hex 6-32	1
100302	Ball - 1/8 Dia.	1
100352	Washer - Plain #1	1
100440	Washer - 5/16 Plain	2
100955	Nut - Hex 8-32	1
101056	O Ring	2
101148	O Ring	1
101326	Nut - Hex 10-24	1
101563	Screw - Socket 10-24	1
102067	Nut - Stop 10-24	1
102115	Washer - Plain	1
102130	Screw - Hex 1/4-20	1
102144	Screw - Fil 10-24	1
102761	Screw - Hex 10-24	1
102762	Screw - Hex 10-24	1
102809	Ball - .093 Dia.	1
103357	Screw - Hex 10-24	1
103579	Screw - Flat 10-24	1
103672	Screw - Fil 8-32	3
103879	Key - Woodruff	1
104001	O Ring	1
104357	Bearing - Needle	1
104534	Screw - Socket 10-24	1
104816	Screw - Hex 10-24	2
105673	Pin - Roll	1
105976	Washer - Flat	2
106078	Screw - Sem 10-24	2
106104	Seal - O Ring	1
110127	Screw - Hex 10-24	1
110260	Seal - Oil	1
110264	Washer - Special #10	1
110288	Screw - Washer 8-32	2
110291	Screw - Pan 10-24	1
110330	Bearing - Sprocket	1
110341	Screw - Hex 10-24	1
110346	Screw - Hex 6-32	1
110378	Pin - Roll 3/16	1
110386	Screw - Hex 8-32	1
110387	Washer - Wavey	1
110402	Screw - Oval 12-24	1
110445	Screw - Tr hd	1
110454	Nut - Hex 5/16-24	1
110470	Rivet - Rd hd	1
110472	Screw - Socket hd	1

Pro Mac 60 Numerical Order Parts List (Continued)

Part Number	Description	Units Per Assy
110529	Screw - Hex 10-24	1
110565	Ring - Retaining	1
110566	Screw - Hex 12-24	2
110567	Screw - Hex 12-24	1
110568	Screw - Hex 12-24	1
110584	Screw - Pan 8-32	1
110590	Bearing	2
110618	Screw - Washer 8-32	1
110646	Screw - Oval 8-32	1

Part Number	Description	Units Per Assy
110668	Screw - Fil 8-36	1
110681	Screw - Socket 10-24	1
110682	Screw - Hex 10-24	1
110703	Nut - Hex flange	1
110706	Screw - Pan 8-18	1
110713	Screw - Socket 10-24	1
110741	Screw - Pan 10-24	1
110811	Screw - Pan 8-32	1
110851	Pin - Dowel	1

Leon's Chainsaw Parts & Repair
Do Not Sell Or Reproduce

Models	Serial Number Prefix
600036A	11-, 12
600036B	11-, 12
600036C	11-
600036D	11-, 12
600036J	11-, 12

PRO MAC 60 CHAIN SAW

ILLUSTRATED PARTS LIST

Pro Mac 60 chain saws are identified by a model number (600036) followed by a suffix letter (A, B, C, etc.) stamped on the identification plate attached to the saw. Suffix letters denote variations in parts or assemblies in manufacture of the saw.

Part numbers listed in this I.P.L. which have a suffix letter or letters following the description, indicate the part is used only on the model identified by that letter or letters.

Part numbers and descriptions without suffix letter or letters apply to all models of the Pro Mac 60 saw.

I.P.L. 89321 supersedes and cancels
I.P.L. 87717

The policy of McCulloch Corporation is one of continual improvement in design, manufacturing and engineering advancement wherever possible to assure still finer two-cycle power tools. Hence, specifications, equipment, colors, design and manufacturer's suggested list prices are subject to change without notice and McCulloch Corporation reserves the right to make such changes without prior notification or obligation to backfit or supply backfit components for units previously shipped from the factory.

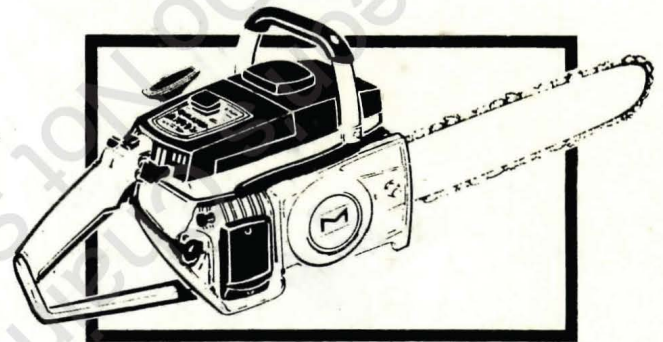

JULY 1973

	Page
Figure 1. General.....	2
Figure 2. Fan Housing & Starter Assemblies	4
Figure 3. Fuel Tank Assembly	4
Figure 4. Carburetor Assembly ...	6
Figure 5. Carburetor Assembly ...	6
Figure 6. Powerhead Assembly....	8
Figure 7. Bar & Chain Assembly ..	10

 **McCULLOCH**

COPYRIGHT U.S.A. 1973
McCULLOCH CORPORATION
Printed in U.S.A.

89321