

ILLUSTRATED PARTS LIST

MODELS	SERIAL NUMBER PREFIX	MODELS	SERIAL NUMBER PREFIX
600031A	13-	600031E	11-,12-,13-
600031B	12-,13-	600031F	12-,13-
600031D	11-,12-,13-	600031U	11-,12-,13-

Pro Mac 55 chain saws are identified by a model number (600031) followed by a suffix letter (A, B, D, E, F, U) stamped on the identification plate attached to the saw. Suffix letters denote variations in parts or assemblies in the manufacture of the saw.

Part numbers listed in this IPL which have a suffix letter or letters following the description, indicate the part is used only on the model(s) identified by the letter or letters.

Part numbers and descriptions without suffix letter or letters apply to all models of the Pro Mac 55 chain saw.

Part numbers which have one or more dots (.) preceding their description may be ordered individually but they are also included in the kit or assembly whose description begins directly above the dot(s).

Part numbers which have changed since the previous printing of the IPL covering these saws, are indicated by a dash (-) preceding the new part number.

The policy of McCulloch Corporation is one of continual improvement in design, manufacturing and engineering advancement wherever possible to assure still finer two-cycle power tools. Hence, specifications, equipment, colors, design and manufacturer's suggested list prices are subject to change without notice and McCulloch Corporation reserves the right to make such changes without prior notification or obligation to backfit or supply backfit components for units previously shipped from the factory.

PRO MAC 55 Chain Saw



March 1977

- CONTENTS -

	<u>Page</u>
Figure 1. General	2
Figure 2. CHAIN BRAKE & Spike Asys ..	4
Figure 3. Fan Housing & Starter Asys ...	4
Figure 4. Carburetor Assembly	6
Figure 5. Carburetor Assembly	6
Figure 6. Carburetor Assembly	8
Figure 7. Fuel Tank Assembly	8
Figure 8. Powerhead Assembly	10
Service Specifications	5
Accessories	9



McCULLOCH

© U.S.A. 1976 - McCULLOCH CORPORATION

Printed in U.S.A.

92384A-R1

(This IPL supersedes & replaces IPL, P/N 92050)

PRO MAC 55

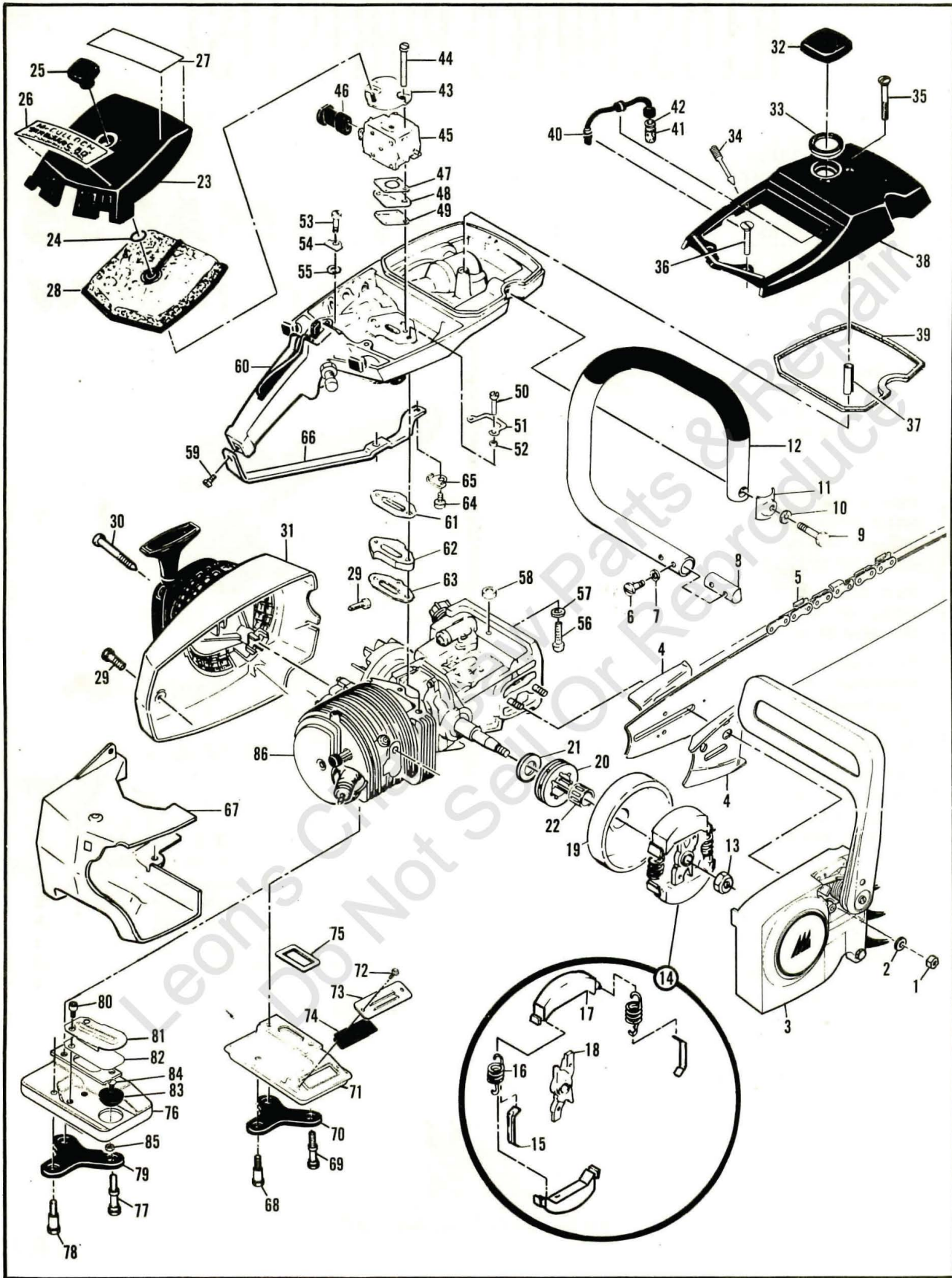

Figure 1. General View - Exploded

Figure 1. General

Item No.	Part Number	Description	Units Per Asy
1	110454	Nut - Hx 5/16 - 24	2
2	100440	Washer - 5/16	2
3		CHAIN BRAKE & Spike Asys (Fig. 2)	
4	-64330	Set - Bar plates	1
5		Bar & Chain	
6	110865	Screw - Hx hd 10-24 x 7/8	2
7	100352	Washer - #10	2
8	89727	Retainer - Frame	1
9	102130	Screw - Hx hd 1/4 - 20 x 1-1/2	1
10	100153	Washer - Lock 1/4	1
11	63484	Clamp - Frame	1
12	-87686A	Frame & Grip Asy	1
13	86113	Nut - Hx 3/8 - 24 (L.H.)	1
14	87675	Clutch Asy	1
15	64583	. Retainer - Spring	2
16	83223	. Spring - Clutch	2
17	67233	. Shoe - Clutch	2
18	89438	. Rotor Asy	1
19	86946	① Drum/Spkt Asy-7T .375P	1
20	86951	① . Sprocket-7T .375P	1
21	86958	① . Washer - Shim	1
(19)	-86942	② Drum/Spkt Asy-7T .375P(A)	1
(20)	-86344	② . Sprocket-7T .375P (A)	1
(21)	86958	② . Washer-Shim (A)	1
22	110330	Bearing - Sprocket	1
23	68530A	Cover Asy - Air cleaner	1
24	110565	. Ring - Retainer	1
25	68529	. Knob - Cover	1
26	-91548	② Plate - Instruction	1
27	91546	Plate - Name	1
28	69922	Filter - Air	1
29	110741	Screw - Pan hd 10-24 x 1/2	2
30	87871	Screw - Special	3
31		Fan Housing & Starter Asy (Fig. 3)	
32	89322	Cap Asy - Fuel	1
33	69767	. Gasket - Fuel cap	1
34	-87932	③ Screw - Idle adjustment	1
35	110402	Screw - Oval hd 10-24 x 2-3/8	1
36	103579	Screw - Fil hd 10-24 x 1	2
37	87840	Spacer	1
38	69679	④ Cover - Fuel Tank	1
(38)	-88650	③ Cover - Fuel Tank	1
39	69345	Gasket - Fuel tank cover	1
40	64848	Hose Asy - Fuel	1
41	63932	. Filter - Fuel	1
42	100440	. Washer - 5/16	1
43	83204	Kit - Air cleaner bracket	1
44	103357	. Bolt - Hx hd 10 - 24 x 2-1/4	2

Item No.	Part Number	Description	Units Per Asy
45		Carburetor Asy (Fig. 4, 5, 6)	
46	-87665	③ Boot - Carburetor adj.	1
47	86189	Gasket - Carburetor	1
48	84078	Spacer - Carburetor	1
49	84081	Gasket - Spacer	1
50	110570	Screw - Hx hd 12-24 x 1-3/8	2
51	68582	Plate - Lock	1
52	102115	Washer - #12	2
53	110568	Screw - Hx hd 12-24 x 1-1/8	1
54	69516	Plate - Lock	1
55	64856	Washer - Special	1
56	110713	Screw - Skt hd 10-24 x 7/8	1
57	100003	Washer - #10	1
58	69772	Spacer - Fuel tank	1
59	-110910	Screw - Hx hd 10-24 x 1-1/4	1
60		Fuel Tank Asy (Fig. 7)	
61	84082	Gasket - Fuel tank	1
62	84079	Insulator - Fuel tank	1
63	84082	Gasket - Fuel tank	1
64	110566	Screw - Hx hd 10-24 x 5/8	1
65	68508	Plate - Lock	1
66	85007	Brace - Handle	1
67	-85731A	Shroud - Cylinder	1
68	67837	Screw - Muffler short	1
69	67838	Screw - Muffler long	2
70	83993	Plate - Lock	1
71	-95318	⑤ Muffler Asy	1
72	110662	⑤ . Screw - Pan hd 6-32 x 3/8	2
73	-95320	⑤ . Cover - Screen	1
74	89431	⑤ Screen - Spark arrester	1
75	84007	Gasket - Muffler	1
76	-68863	② Kit - Pancake Reed Muffler	1
77	67838	② . Screw - Muffler long	2
78	67837	② . Screw - Muffler short	1
79	83993	② . Plate - Lock	1
80	-110563	② . Screw - Skt hd 8-32 x 1/4	2
81	-84780	② . Stop - Reed	1
82	-84779	② . Valve - Spark arrester	1
83	-85933	② Kit - Spark Arrester Screen (A)	1
84	-101987	② . Screw - Rd hd 6-32 x 1/4 (A)	1
85	-100796	② . Nut - Hx 6-32 (A)	1
86		Powerhead Asy (Fig. 8)	

- ① Used on models with serial number prefix 11- and 12-; also 13- with model number suffix letter B, D, E, F, and U.
- ② Used on models with serial number prefix 13-.
- ③ Used on models with Carburetor Asy, P/N 87666 (Figure 6).
- ④ Used on models with Carburetor Asy, P/Ns 89324, 91275, 91121 (Figures 4,5).
- ⑤ Used on models with serial number prefix 11- and 12-.

PRO MAC 55

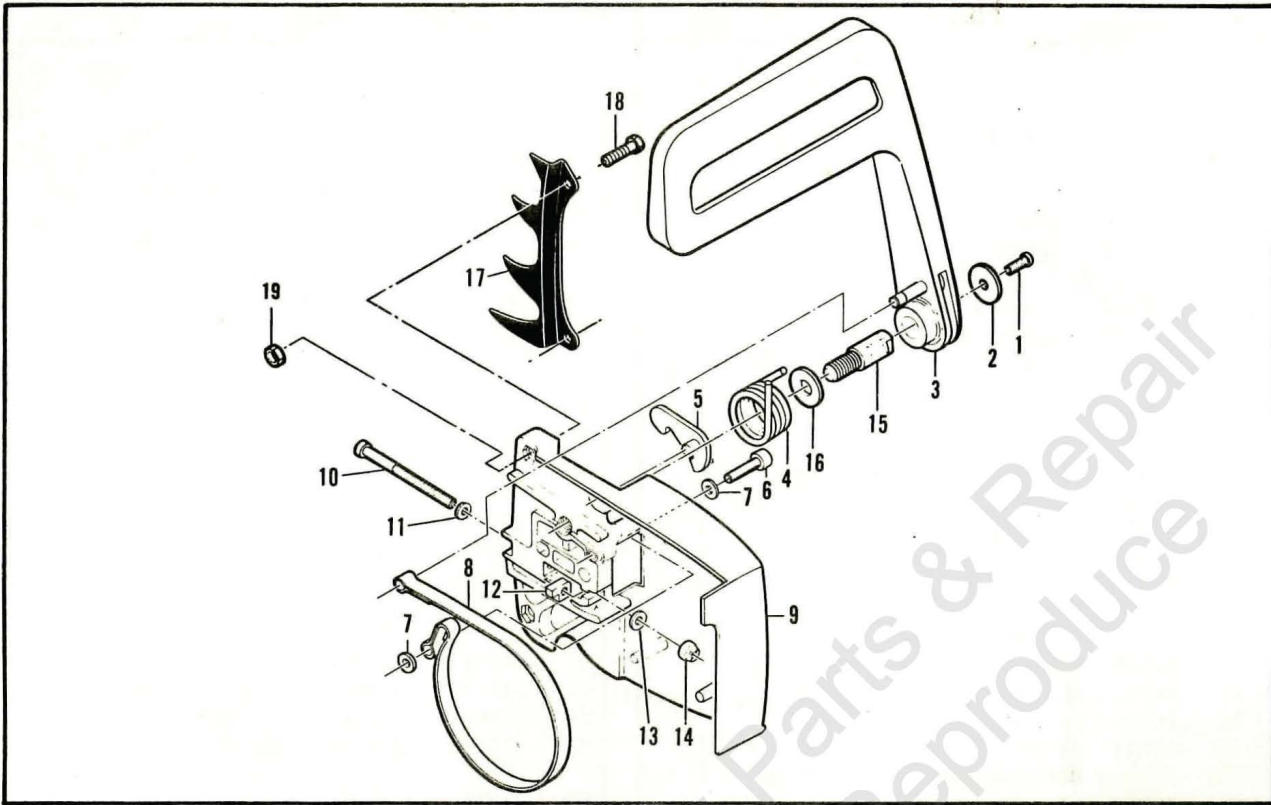

Figure 2. CHAIN BRAKE & Spike Assemblies

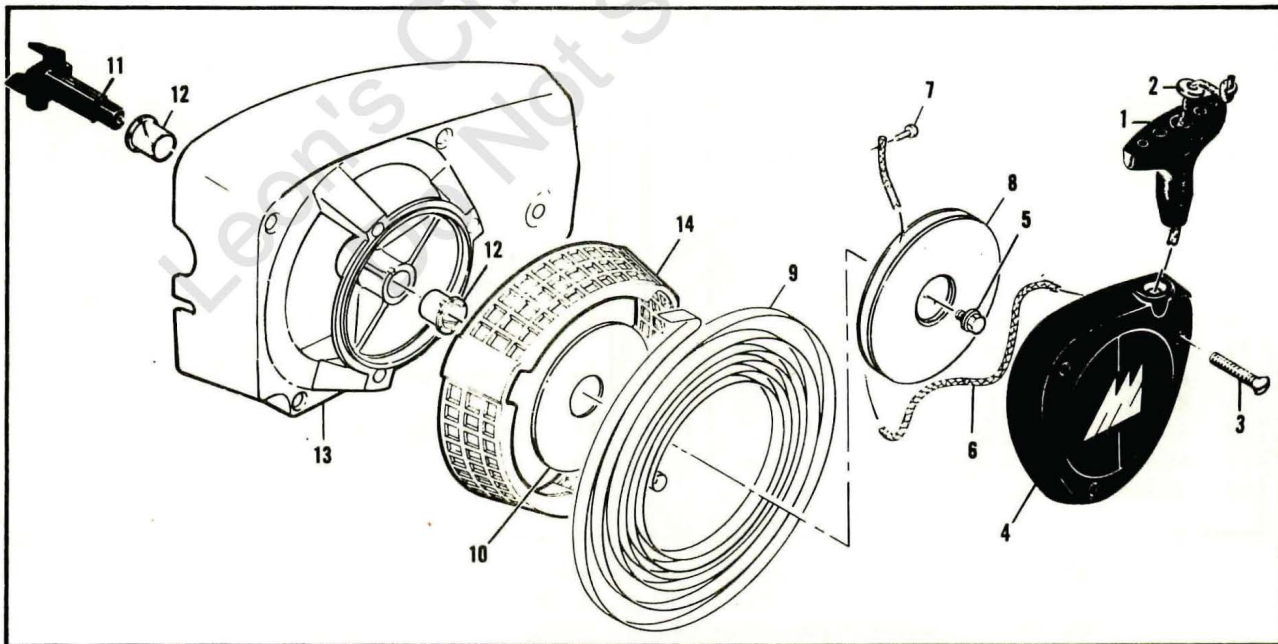

Figure 3. Fan Housing & Starter Assemblies

Figure 2. CHAIN BRAKE & Spike Assemblies

Item No.	Part Number	Description	Units Per Asy.
	91278	CHAIN BRAKE Asy	1
1	102500	. Screw - Pan hd 10-24 x 1/2	1
2	91273	. Washer - Special	1
3	91251	. Lever Asy	1
4	91239	. Spring	1
5	-91235A	. Latch Asy	1
6	105738	. Screw - Skt hd 1/4-20 x 7/8	1
7	91274	. Washer - Special	2
8	91238	. Band	1
9	91249	. Housing Asy	1

Item No.	Part Number	Description	Units Per Asy.
10	110527	. . Screw - Fil hd 10-24 x 2-3/4	1
11	110264	. . Washer - #10	1
12	61705	. . Nut - Bar adjusting	1
13	100002	. . Washer - #10	1
14	102067	. . Nut - Hx 10-24	1
15	91246	. . Pin - Lever pivot	1
16	91245	. . Washer - Thrust	1
17	86330	Kit - Spike	1
18	102388	. Screw - Hx hd 10-24 x 5/8	2
19	101191	. Nut - Hx 10-24	2

Service Specifications

Spark Plug Gap	-	.025 inch (.63 mm)
Lamination Gap	-	.010 to .012 inch (.25 to .30 mm)
Breaker Point Gap	-	.019 to .020 inch (.48 to .51 mm)
Timing	-	26° BTDC
Clutch Engagement Speed		2800 to 3000 R.P.M.
Torques	-	Connecting Rod Screws: 65 to 70 pound x inches (8.5 to 9.2 N.m)
		Clutch Nut: 160 to 170 pound x inches (18 to 19 N.m)
		Flywheel Nut: 265 to 325 pound x inches (30 to 37 N.m)

Figure 3. Fan Housing & Starter Assemblies

Item No.	Part Number	Description	Units Per Asy.
1	91255	Kit - Starter handle	1
2	105490	. Washer - Starter handle	1
3	87667	Fan Housing & Starter Asy	1
	110646	. Screw - Oval hd 8-32 x 1-1/8	3
4	87672	. Cover - Starter	1
5	110341	. Screw - Hx hd 10-24 x 1/2	1

Item No.	Part Number	Description	Units Per Asy.
6	68162	. Rope-Starter	1
7	110470	. Rivet-Rope	1
8	85122	. Drum-Starter	1
9	87680	. Spring-Rewind	1
10	86053	. Shield-Spring	1
11	83748	. Shaft-Starter	1
12	57535	. Bushing - Starter	2
13	87693	. Kit-Fan Housing	1
14	87674	. . Guard-Sawdust	1

PRO MAC 55

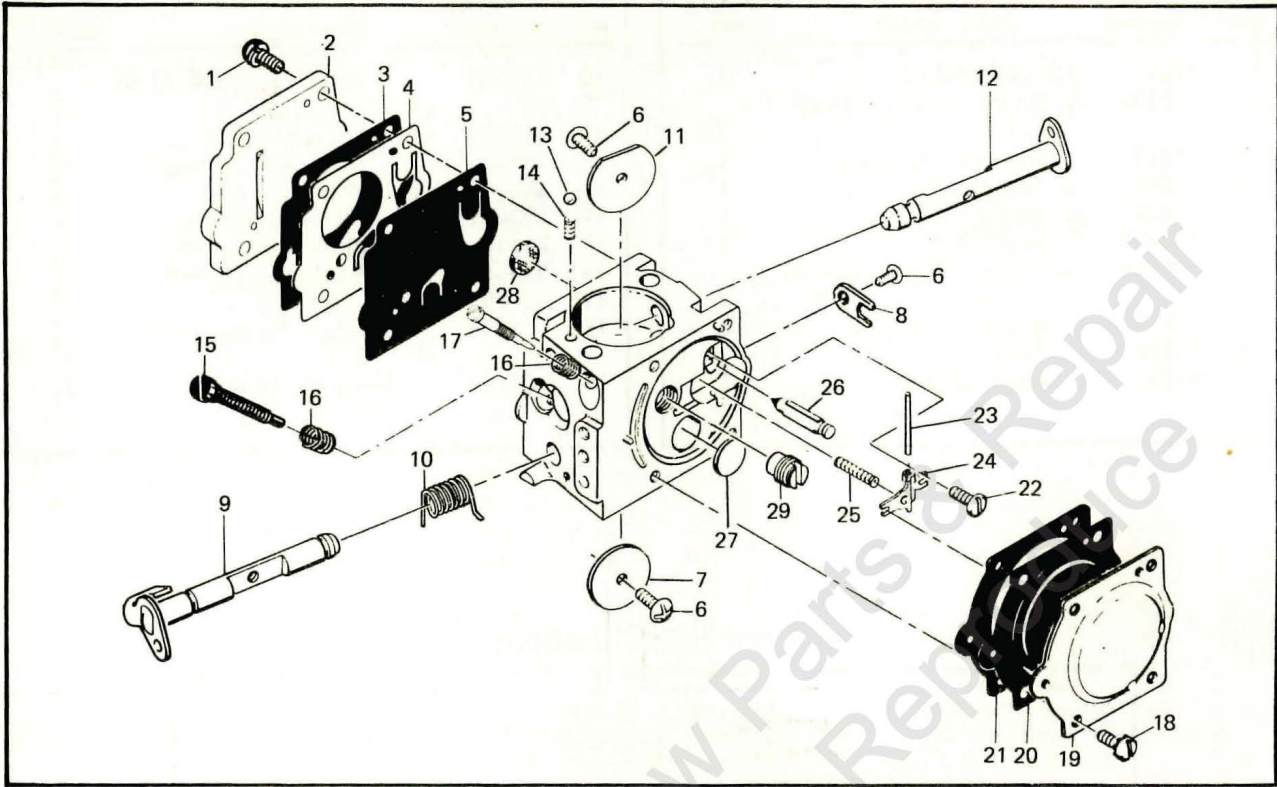

Figure 4. Carburetor Assembly (SDC)

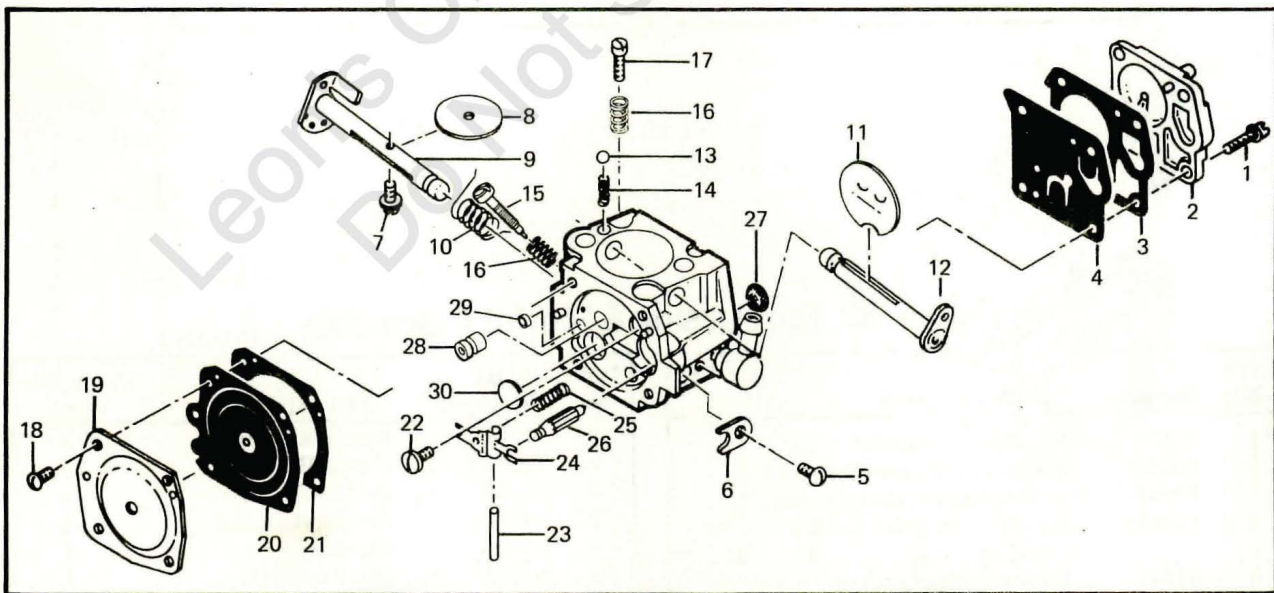

Figure 5. Carburetor Assembly (HS)

Figure 4. Carburetor Assembly

Item No.	Part Number	Description	Units Per Asy.	Item No.	Part Number	Description	Units Per Asy.
	89324	① Carburetor Asy - SDC	1	19	83761	. Cover - Diaphragm	1
	91275	② Carburetor Asy - SDC	1	20	67499	④. Diaphragm - Metering	1
1	67501	. Screw - Pump cover	4	21	67496	③. Gasket - Diaphragm	1
2	88731	. Kit - Pump cover	1	22	67500	. Screw - Lever pin	1
3	88617	③. . Gasket - Cover	1	23	67508	④. Pin - Lever	1
4	67498	④. Diaphragm - Check valve	1	24	67509	④. Lever - Inlet	1
5	83114	④. Diaphragm - Fuel pump	1	25	67503	④. Spring - Lever	1
6	47690	④. Screw - Plate	3	26	67491	④. Valve - Needle	1
7	83762	. Plate - Throttle	1	27	71690	④. Plug - 3/8	1
8	67489	. Clip - Shaft	1	28	67507	④. Screen - Fuel	1
9	67486	. Shaft Asy - Throttle	1	29	90346	①. Jet - High speed (032)(std)	1
10	85981	. Spring - Throttle return	1		90347	① Jet - H/S (033)	Alt.
11	67490	. Plate - Choke	1		90348	① Jet - H/S (031)	Alt.
12	67488	. Shaft Asy - Choke	1		90349	Jet - H/S (029)	Alt.
13	100302	④. Ball - Choke friction	1		90350	① Jet - H/S (028)	Alt.
14	67504	④. Spring - Choke friction	1		90351	Jet - H/S (026)	Alt.
15	68106	④. Screw - Idle speed	1		90350	②. Jet - High speed (028)(std)	1
16	67502	④. Spring - Idle	2		88620	Kit - Repair	
17	90345	. Needle - Idle mixture	1		88619	④ Set - Gasket	
18	70798	. Screw - Diaphragm cover	4				

NOTE: Before ordering parts, identify carburetor on saw.

- ① Used on models with serial number prefix 11-.
- ② Used on models with serial number prefix 12-, 13-.
- ③ Contained in Gasket Set, P/N 88619.
- ④ Contained in Repair Kit, P/N 88620.

Figure 5. Carburetor Assembly

Item No.	Part Number	Description	Units Per Asy	Item No.	Part Number	Description	Units Per Asy
	91121	① Carburetor Asy - HS	1	18	51721	. Screw - Diaphragm cover	4
1	52933	. Screw - Pump cover	4	19	83724	. Cover - Diaphragm	1
2	66628	. Cover - Pump	1	20	66632	③. Diaphragm - Metering	1
3	66629	②. Gasket - Pump cover	1	21	66633	②. Gasket - Diaphragm	1
4	66630	③. Diaphragm - Fuel pump	1	22	66644	④. Screw - Inlet lever pin	1
5	48780	. Screw - Throttle shaft clip	1	23	66636	④. Pin - Inlet lever	1
6	66646	. Clip - Throttle shaft	1	24	66638	④. Lever - Inlet	1
7	48780	④. Screw - Throttle plate	1	25	66404	④. Spring - Inlet lever	1
8	51720	. Plate - Throttle	1	26	66637	. Needle - Inlet	1
9	87922	. Shaft Asy - Throttle	1	27	66623	④. Screen - Fuel inlet	1
10	67136	④. Spring - Throttle shaft	1	28	88771	. Jet - H/S fuel (029)	1
11	65856	. Plate - Choke	1		88772	Jet - H/S fuel (028)	Alt.
12	83725	. Shaft Asy - Choke	1		88781	Jet - H/S fuel (027)	Alt.
13	100071	. Ball - Choke friction	1	29	52928	. Plug - Cup	1
14	48759	. Spring - Choke friction	1	30	66622	④. Plug - Welch	1
15	88768	. Needle - Idle mixture	1		88774	③ Set - Gasket	
16	66626	④. Spring - Idle	2		88775	Kit - Repair	
17	66625	. Screw - Idle speed adjust	1		88776	④ Set - Gasket Diaphragm	

NOTE: Before ordering parts, identify carburetor on saw.

- ① Used on models with serial number prefix 11-, 12-, 13-.
- ② Contained in Gasket Set, P/N 88774.
- ③ Contained in Gasket & Diaphragm Set, P/N 88776.
- ④ Contained in Repair Kit, P/N 88775.

PRO MAC 55

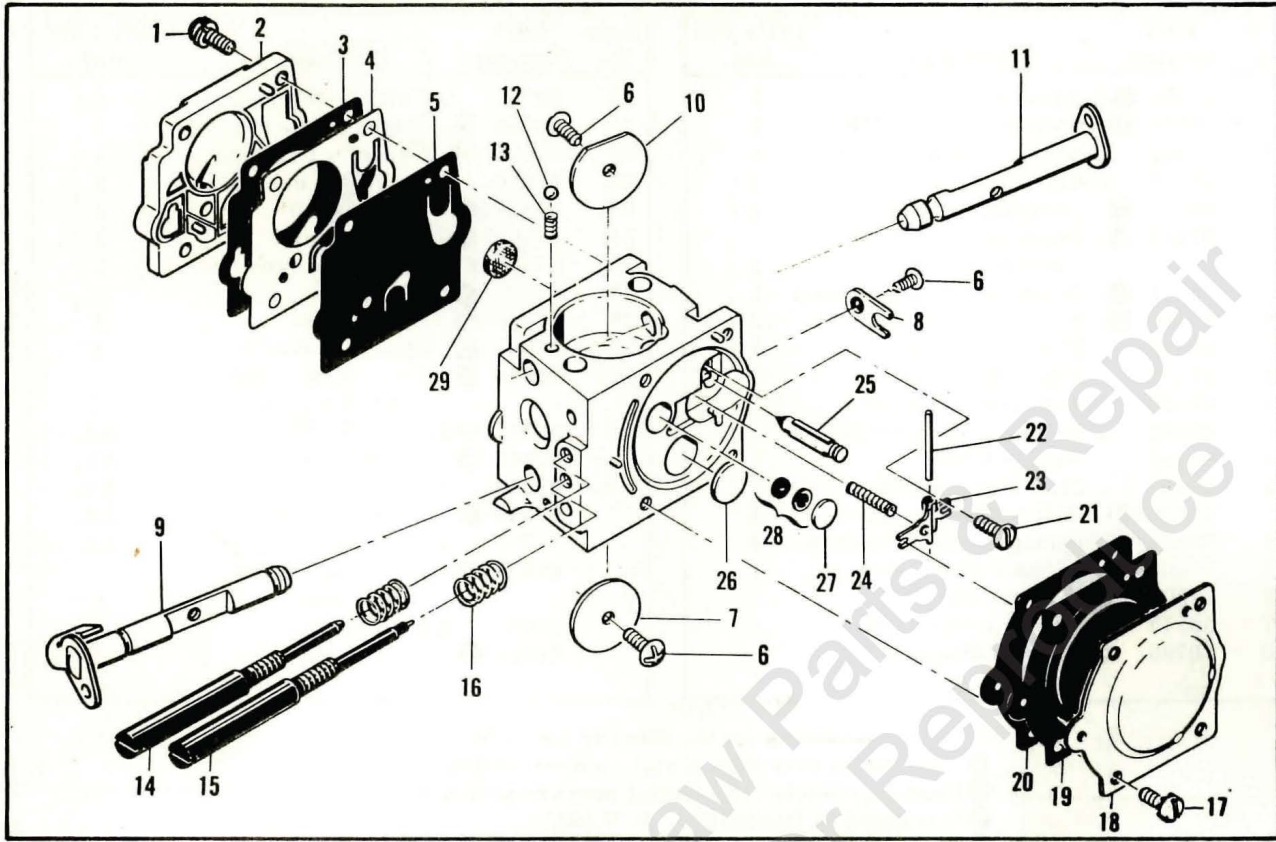

Figure 6. Carburetor Assembly

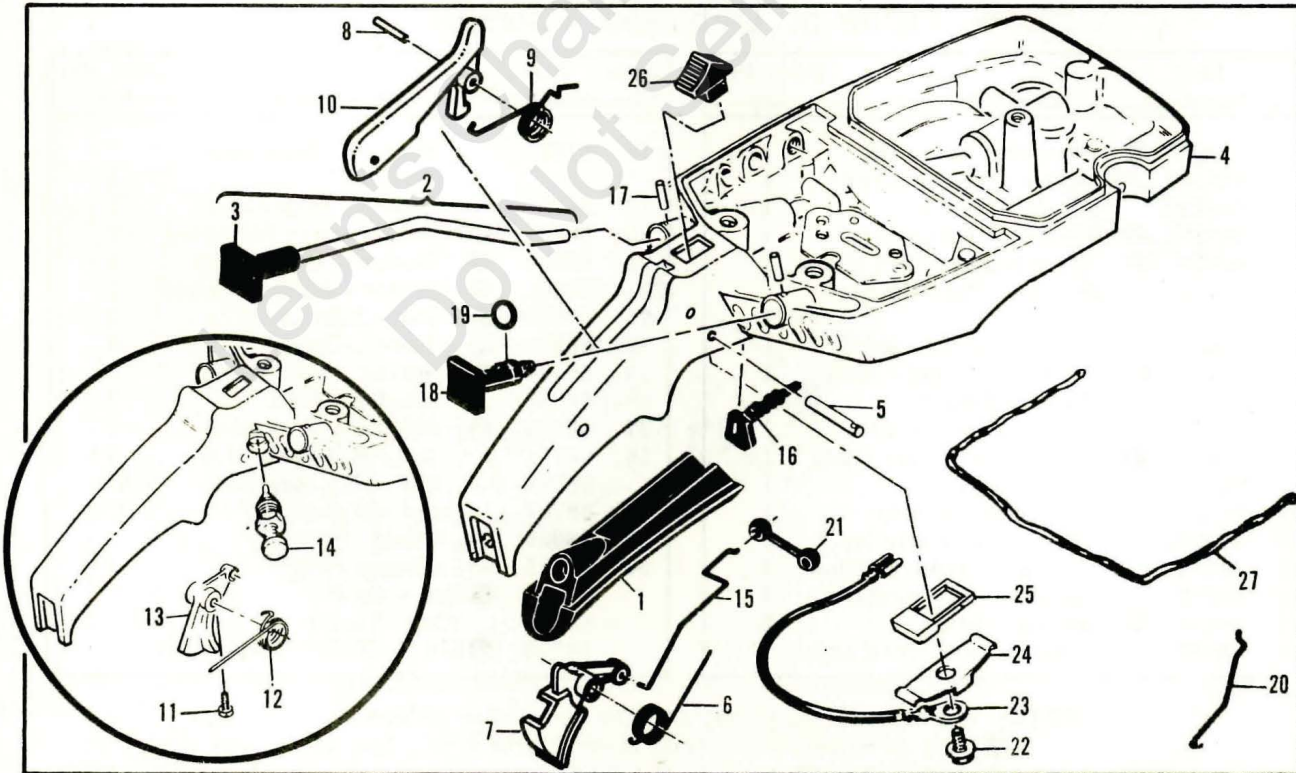

Figure 7. Fuel Tank Assembly

Figure 6. Carburetor Assembly

Item No.	Part Number	Description	Units Per Asy	Item No.	Part Number	Description	Units Per Asy
-	87666	① Carburetor Asy	1	15	87916	. Needle - Idle	1
1	67501	. Screw - Pump cover	4	16	67502	. Spring - Needle	2
2	83760	. Cover - Pump	1	17	70798	. Screw - Diaphragm cover	4
3	67495	. Gasket - Cover	1	18	83761	. Cover - Diaphragm	1
4	67498	. Diaphragm - Check valve	1	19	67499	. Diaphragm - Metering	1
5	83114	. Diaphragm - Fuel pump	1	20	67496	. Gasket - Diaphragm	1
6	47690	. Screw - Plate	3	21	67500	. Screw - Lever pin	1
7	83762	. Plate - Throttle	1	22	67508	. Pin - Lever	1
8	67489	. Clip - Shaft	1	23	67509	. Lever - Metering	1
9	67486	. Shaft Asy - Throttle	1	24	67503	. Spring - Lever	1
10	67490	. Plate - Choke	1	25	67491	. Valve - Needle	1
11	67488	. Shaft Asy - Choke	1	26	71690	. Plug - 3/8	1
12	100302	. Ball - Choke friction	1	27	69506	. Plug - 5/16	1
13	67504	. Spring - Choke	1	28	83758	. Kit - Valve & Seat Asy	1
14	87915	. Needle - High speed	1	29	67507	. Screen - Fuel	1

Note: Before ordering parts, identify carburetor on saw.

① Used on models with serial number prefix 13-.

Accessories

Part Number	Description
84453	Kit - Piston tool
69191	Kit - Pressure test adaptor
84922	Kit - Baffle
86419	Guide - Timing
85933	Kit - Spark arrester screen

Part Number	Description
63097	Spark Plug (Standard)
63432	Spark Plug (Cooler)
62827	Wrench/Screwdriver
65370	Kit - Spkt 7T .354 P
63746	Srench

Figure 7. Fuel Tank Assembly

Item No.	Part Number	Description	Units Per Asy.	Item No.	Part Number	Description	Units Per Asy.
1	89320	Insert - Handle grip	1	15	85107	Rod - Throttle	1
2	64871	Button & Rod Assembly	1	16	-68522A	Seal - Throttle rod	1
3	63044	. Button - Oiler	1	17	105673	Pin - Roll 3/32 x 9/16	2
4	-84183A	Kit - Fuel Tank/Control	1	18	69041	Button - Choke	1
5	110378	. Pin - Roll 3/16 x 15/16	1	19	105614	"O" Ring	1
6	-92152	① Spring - Trigger	1	20	69042	Rod - Choke	1
7	-92151	① Trigger - Throttle	1	21	69043	Snubber - Rod	1
8	-105654	① Pin - Roll 1/8 x 7/8	1	22	110706	Screw - Fil hd 8-18 x 1/2	1
9	-92154	① Spring - Trigger release	1	23	62973A	Wire Asy - Stop switch	1
10	-92153A	① Release - Trigger	1	24	62451	Control - Switch	1
11	110668	② Screw - Fil hd 8-36 x 5/8	1	25	62950A	Base - Switch	1
12	87178	② Spring - Throttle return	1	26	68846	Button - Switch	1
13	88796	② Trigger	1	27	69564	③ Seal - Airbox	1
14	85451	② Latch Asy - Throttle	1				

① Used on models with serial number prefix 13-.

② Used on models with serial number prefix 11-, 12-.

③ Furnished on a 12-1/2 inch strip containing 9 beads (enough for 9 replacements).

PRO MAC 55

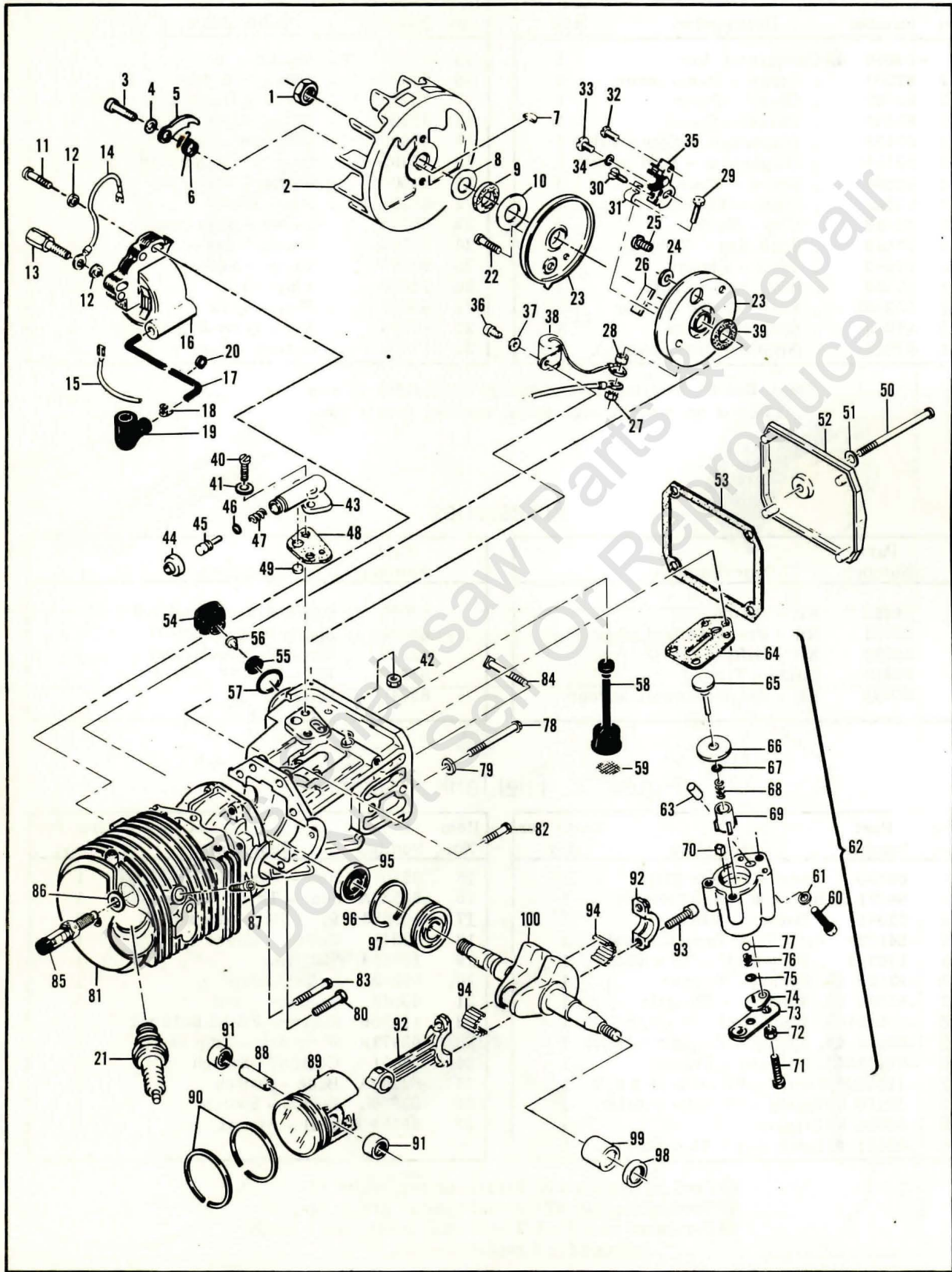

Figure 8. Powerhead Assembly

Figure 8. Powerhead Assembly

Item No.	Part Number	Description	Units Per Asy	Item No.	Part Number	Description	Units Per Asy
1	110703	Nut - Hx 3/8-24	1	51	110921	Washer - Sealing	1
2	86068	Flywheel	1	52	86304	Cover - Oil tank	1
3	88804	Screw - Pawl pivot	2	53	86306	Gasket - Cover	1
4	83241	Washer - Special	2	54	87270	Cap - Oil tank	1
5	67546	Pawl - Starter	2	55	87269	Retainer - Valve	1
6	67545	Spring - Pawl	2	56	86402	Valve - Check	1
7	100106	Key - Woodruff	1	57	101148	"O" Ring	1
8	67057	Washer - Thrust	1	58	91672	Hose Asy - Oil	1
9	67056	Seal - Breaker box cover	1	59	51506	. Screen - Hose	1
10	67054	Washer - Thrust	1	60	110865	Screw - Hx hd 10-24 x 7/8	1
11	110127	Screw - Hx hd 10-24 x 7/8 (SEMS)	1	61	100003	Washer - #10	1
12	100002	Washer - #10	2	62	-89115A	Pump Asy - Pulse	1
13	83512	Stud - Special	1	63	91774	. Sleeve	1
14	84686	Wire Asy - Ground	1	64	-92818	. Seal - Pulse pump	1
15	69344	Wire Asy - Primary	1	65	60260A	. Piston Asy - Pump	1
16	-87246A	Coil & Lamination Asy	1	66	86182	. Ring - Piston	1
17	50120	. Wire Asy - Spark plug	1	67	105603	. "O" Ring	1
18	55061	. . Connector	1	68	60259	. Spring - Piston	1
19	85758	. . Boot	1	69	62227	. Sleeve - Adjustment	1
20	-100268	. Grommet	1	70	-91259	. Pad - Oil pump	1
21	63097	Spark Plug (A, B, D, F, U)	1	71	110386	. Screw - Hx hd 8-32 x 1	1
(21)	-93018	Spark Plug (E)	1	72	100251	. Nut - Hx 8-32	1
22	110584	Screw - Pan hd 8-32 x 3/4	1	73	89114	① Clamp - Pump	1
23	91852	Kit - Breaker box & cover	1	74	62407	. Cover - Outlet valve	1
24	91838	. Washer	1	75	106104	. "O" Ring	1
25	110489	. Screw - Pan hd 6-32 x 7/16	1	76	-92844	. Spring - Outlet valve	1
26	54184	Wiper - Cam	1	77	102809	. Ball	1
27	100298	Nut - Hx 6-32	1	78	62105	Screw Asy - Sealing	4
28	62365	Spacer - Breaker	1	79	62842	. Washer - Sealing	4
29	110346	Screw - Hx hd 6-32 x 3/4	1	80	110288	Screw - Hx hd 8-32 x 3/4	1
30	110706	Screw - Pan hd 8-18 x 1/2	1	81	-89435A	Crankcase Asy	1
31	83126	Strap - Conduction	1	82	110288	. Screw - Hx hd 8-32 x 3/4	2
32	110811	Screw - Pan hd 8-32 x 3/8	1	83	110618	. Screw - Hx hd 8-32 x 1-3/8	1
33	-110969	Screw - Hx hd 8-32 x 1/2	1	84	62065	. Bolt - Bar mounting	2
34	105976	Washer - #8	1	85	-94272	. Valve - Comp. rel.	1
35	88808	Breaker Asy	1	86	85505	. Washer - Valve	1
36	-110623	Screw - Fil hd 8-32 x 1/2	1	87	110681	. Screw - Skt hd 10-24 x 1/4	1
37	100080	Washer - #8	1	88	87710	Pin - Piston	1
38	85358	Condenser	1	89	89783A	Piston Asy	1
39	67051	Seal - Breaker box	1	90	-92517	. Ring Set - Piston	1
40	-110338	Screw - Fil hd 8-32 x 9/16	2	91	110590	. Bearing - Needle	2
41	110613	Washer - #8	2	92	85352	Connecting Rod Asy	1
42	100955	Nut - Hx 8-32	1	93	61627A	. Screw - Skt hd special	2
43	84156	Housing - Pump	1	94	63225	. Roller - Needle (Set of 20)	1
44	62262	Cap - Housing	1	95	67906	Seal - Oil	1
45	62266	Plunger - Pump	1	96	63464	Ring - Snap	1
46	105614	"O" Ring	1	97	67905	Bearing - Ball	1
47	66687	Spring - Pump	1	98	110260	Seal - Oil	1
48	91669	Gasket - Pump	1	99	104357	Bearing - Needle	1
49	91668	Valve - Pump	1	100	87699	Crankshaft	1
50	110291	Screw - Pan hd 10-24 x 2-5/8	1				

① Used on models with serial number prefix 11- and 12-.

McCULLOCH
CORPORATION



● MANUFACTURING ● SALES ● SERVICE ●

McCULLOCH
CORPORATION

P.O. Box 92180, Los Angeles, CA 90009

Copyright - McCulloch.

To answer service-related questions and to solve common consumer problems quickly, we invite you to call this toll-free hot-line:

Arizona residents please call collect (602)453-3681

(800)423-6302

Leon's Chair & Repair
Do Not Sell or Rent