

ILLUSTRATED PARTS LIST

MODELS	SERIAL NUMBER PREFIX	MODELS	SERIAL NUMBER PREFIX
600111-02	11-	600111-05	11-
600111-03	11-	600111-06	11-
600111-04	11-		

McCulloch Chain Saws are identified by a model number (in this instance 600111) followed by a suffix number (02, 03, 04, etc.). Suffix numbers denote variations in parts or assemblies used in the manufacture of this product.

Part numbers listed in this I.P.L. which have a circled number ① or numbers preceding the description, are used only on the model or models identified by a circled number ① or numbers.

Part numbers which have one or more dots (.) preceding their descriptions may be ordered individually, but they are also included in the kit or assembly whose description begins directly above the dot(s).

Part numbers in this IPL which were not in the previous IPL covering these saws, are indicated by a dash (-) preceding the new part number.

The policy of McCulloch Corporation is one of continual improvement in design, manufacturing and engineering advancement wherever possible to assure still finer power tools. Hence, specifications, equipment, colors, design and manufacturer's suggested list prices are subject to change without notice and McCulloch Corporation reserves the right to make such changes without prior notification or obligation to backfit or supply backfit components for units previously shipped from the factory.

SEPTEMBER 1987

THE PROFESSIONAL

PRO MAC™ CHAIN SAW

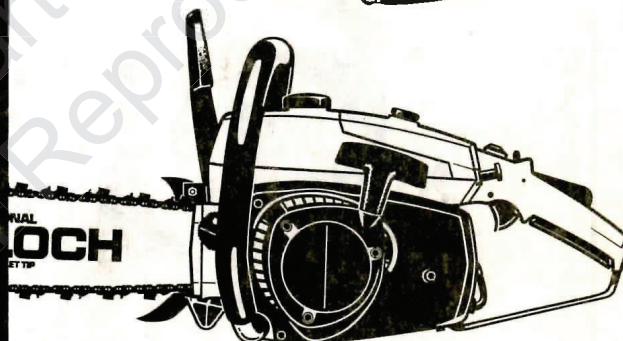
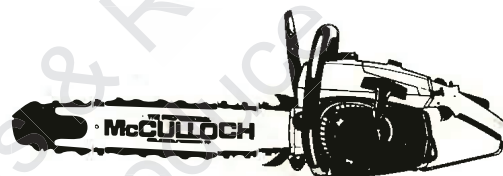

- CONTENTS -

	PAGE
Figure 1. General	2
Service Specifications	3
Figure 2. CHAIN BRAKE Assembly	4
Figure 3. Fan Housing & Starter Asys.	5
Accessories	5
Figure 4. Fuel Tank Assembly	6
Figure 5. Carburetor Assembly	7
Figure 6. Powerhead Assembly	8
Bar & Chain Combinations	9

McCULLOCH
CORPORATION

Figure 1 GENERAL ASSEMBLY

PRO MAC™ 10-10S

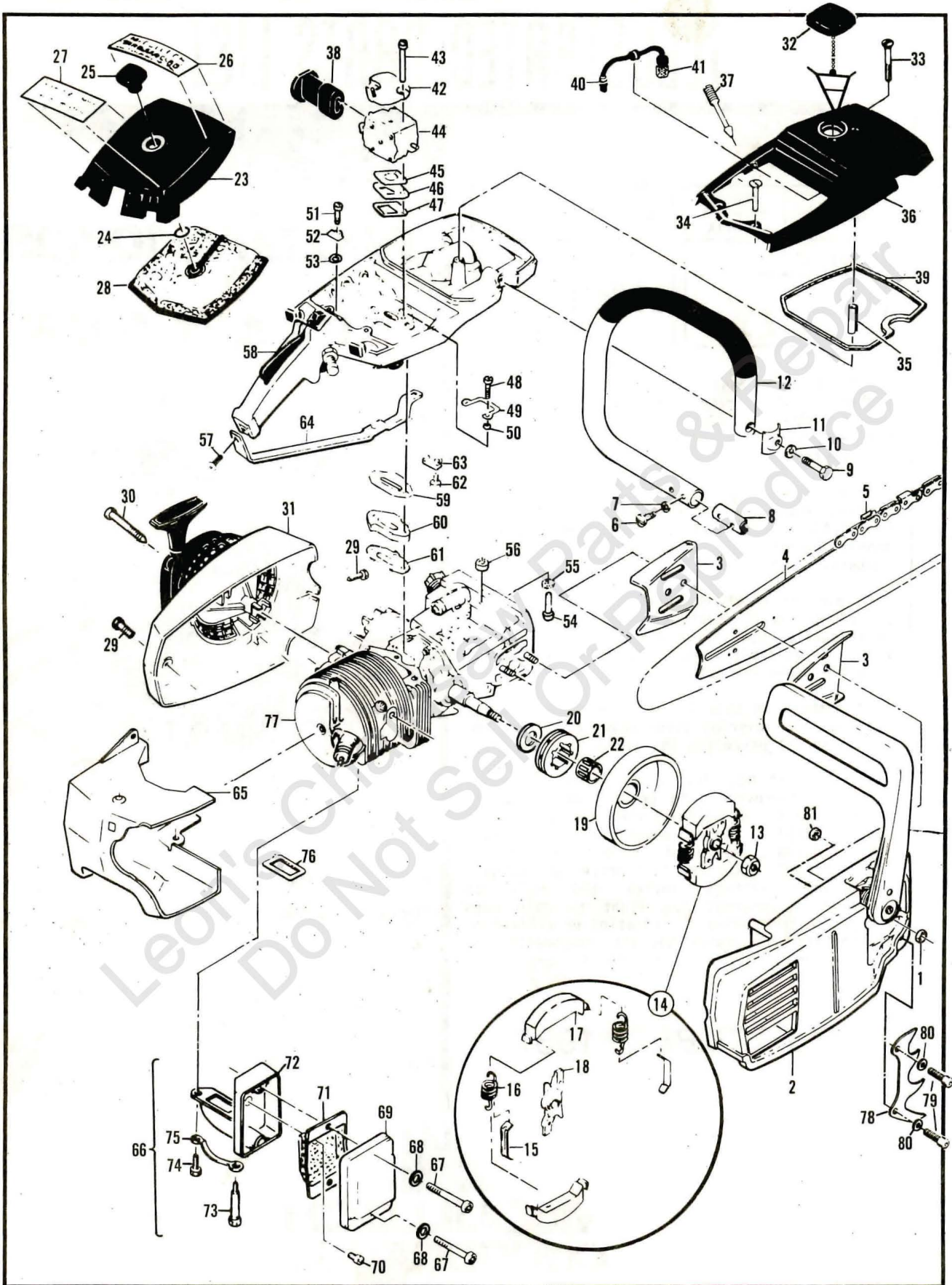

FIGURE 1 GENERAL ASSEMBLY

ITEM NO.	PART NUMBER	DESCRIPTION	UNITS PER ASY.	ITEM NO.	PART NUMBER	DESCRIPTION	UNITS PER ASY.
1	110961	NUT - HEX 5/16-24	2	42	69952	BRACKET - AIR CLEANER	1
2		CHAIN BRAKE ASSEMBLY (FIG. 2)		43	103357	BOLT - HEX HD 10-24 x 2 1/4	2
3	64330	SET - BAR PLATE	1	44		CARBURETOR ASSEMBLY (FIG. 4)	
4		BAR ASSEMBLY	1	45	86189	GASKET - CARBURETOR	1
5		CHAIN ASSEMBLY	1	46	84078	SPACER - CARBURETOR	1
6	110865	SCREW - HEX HEAD 10-24 x 7/8	2	47	84081	GASKET - SPACER	1
7	100352	WASHER - #10 PLAIN	2	48	110570	SCREW - HEX HD 12-24 x 1 3/8	2
8	89727	RETAINER - FRAME	1	49	68582	LOCKPLATE	1
9	102130	SCREW - HEX HD 1/4-20 x 1.5	1	50	102115	WASHER - PLAIN	2
10	216542	WASHER - LOCK 1/4	1	51	110568	SCREW - HEX HD 12-24 x 1 1/8	1
11	216639	CLAMP - FRAME	1	52	69516	LOCKPLATE	1
12	214549	FRAME AND GRIP ASSEMBLY	1	53	1750-100352	WASHER - SPECIAL	1
13	86113	NUT - HEX 3/8-24 LEFT HAND	1	54	110713	SCREW - SKT HD 10-24 x 1 1/4	1
14	214301	CLUTCH ASSEMBLY	1	55	100003	WASHER - #10	1
15	64583	. RETAINER - CLUTCH SPRING	2	56	69772 ①	SPACER - FUEL TANK	1
16	83223	. SPRING - CLUTCH	2	57	216632	SCREW - BTN 10-24 x 1 1/4	1
17	67233	. KIT - CLUTCH SHOE	2	58		FUEL TANK ASSEMBLY (FIG. 5)	
18	214300	. ROTOR CLUTCH	1	59	84082	GASKET	1
19	95165	DRUM/SPROCKET ASSEMBLY	1	60	84079	INSULATOR - FUEL TANK	1
20	86958	. WASHER - SHIM	1	61	84082	GASKET	1
21	86951	. KIT - SPROCKET	1	62	216680	SCREW - HEX HD 12-24 x 5/8	1
22	215720	BEARING - SPROCKET	1	63	68508	LOCKPLATE	1
23	91543	COVER ASSEMBLY - AIR CLEANER	1	64	85007	BRACE - HANDLE	1
24	110565	. RING - RETAINER	1	65	214702	SHROUD	1
25	68529	. KNOB - COVER	1	66	93992	KIT - MUFFLER	1
26	216055	NAMEPLATE	1	67	101563	. SCREW - SKT HD 10-24 x 1.25	2
27	216054	PLATE - INSTRUCTION	1	68	-216635	. WASHER	2
28	69922	FILTER - AIR	1	69	83966	. COVER ASSEMBLY - MUFFLER	1
29	216670	SCREW - SKT HD 10-24 x .50	2	70	110928	. SCREW - HEX HD 10-24 x 1/2	1
30	216624	SCREW - SPECIAL	3	71	85152	. BAFFLE - SPARK ARRESTER	1
31	Fig. 3	FAN HOUSING/STARTER ASSEMBLIES		72	-83105	. Kit-Body/Duct Asy	1
32	216053	CAP ASSEMBLY - FUEL	1	73	68187	. Screw - Hx 10-24 x 1.38	1
33	216678	SCREW - OVAL 12-24 x 2 3/8	1	74	110529	. SCREW - HEX HD 10-24 x 1/2	1
34	101986	SCREW - OVAL 10-24 x 1	2	75	67922	. LOCKPLATE	1
35	87840	SPACER	1	76	84007	GASKET - MUFFLER	1
36	88650	COVER - FUEL TANK	1	77		POWERHEAD ASSEMBLY (FIG. 6)	
37	-87932	SCREW - IDLE ADJUSTMENT	1	78	91967	KIT - SPIKE	1
38	-87665	BOOT - CARBURETOR	1	79	213042	. SCREW - SKT HD 10-24 x 5/8	2
39	69345	GASKET - COVER	1	80	-216683	. WASHER - SPECIAL	2
40	215708	HOSE ASSEMBLY - FUEL	1	81	-216682	. NUT - HEX 10-24	2
41	215714	. PICKUP ASSEMBLY - FUEL	1				

① Used on some earlier models.

SPECIFICATIONS

WEIGHT:	15.6 lbs. (7.1 kg)
BORE:	1.750 in. (44.5 mm)
STROKE:	1.375 in. (34.9 mm)
DISPLACEMENT:	3.5 cu. in. (57 cc)
COIL LAMINATION TO	
FLYWHEEL AIR GAP:	.011 to .015 in. (30 to 40 mm)
IGNITION TIMING:	26 B.T.D.C.
CLUTCH ENGAGEMENT SPEED:	2800 to 3000 RPM
SPARK PLUG GAP:	.025 in (.63 mm)
GASOLINE:	Regular (Leaded)
FUEL TANK CAPACITY:	1.5 U.S. pints (0.71 liters)

NOTE

For your convenience Service Bulletins which affect part numbers are referenced in this IPL. Service Bulletin numbers are boxed and precede part numbers.

TORQUE VALUES

CONNECTING ROD SCREWS:	65 to 70 inch pounds (8.5 to 9.2 Nm)
CLUTCH NUT:	160 to 170 inch pounds (18 to 19 Nm)
FLYWHEEL NUT:	265 to 325 inch pounds (30 to 37 Nm)

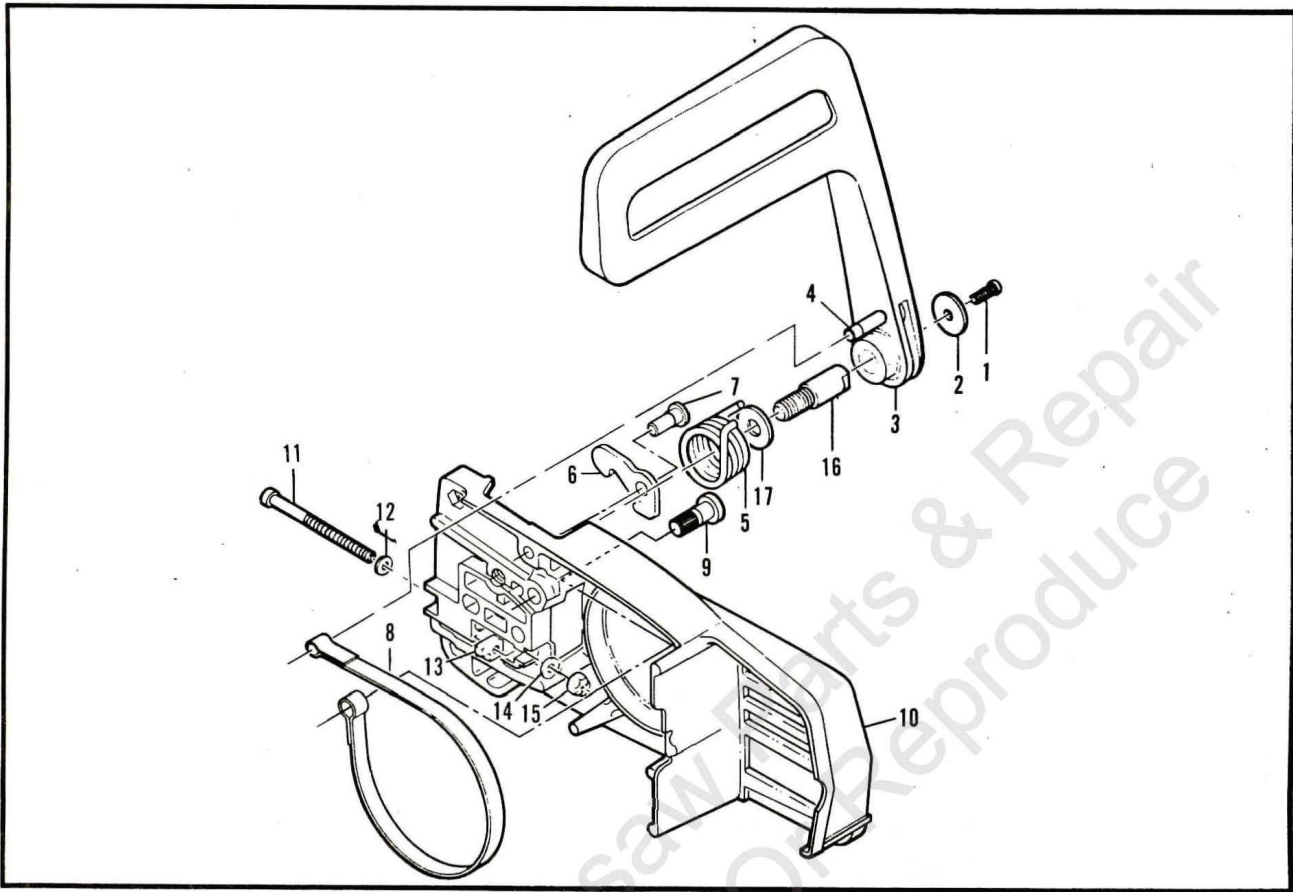

FIGURE 2 CHAIN BRAKE ASSEMBLY

ITEM NO.	PART NUMBER	DESCRIPTION	UNITS PER ASY.	ITEM NO.	PART NUMBER	DESCRIPTION	UNITS PER ASY.
	-217694	CHAIN BRAKE ASSEMBLY	1	10	216771	. HOUSING - BRAKE	1
1	216634	. SCREW - PN HD 10-24 x .50	1	11	216636	. SCREW - FIL 10-24 x 2 3/4	1
2	216633	. WASHER - PLAIN .210 ID	1	12	216635	. WASHER	1
3	215911	. LEVER ASSEMBLY	1	13	61705	. NUT - BAR ADJUSTING	1
4	214366	. PIN ASSEMBLY - ROLLER	1	14	100002	. WASHER - 10 PLAIN	1
5	93085	. SPRING - BRAKE	1	15	102067	. NUT - HEX LOCK 10-24	1
6	217235	. LATCH	1	16	91246	. PIN - LEVER PIVOT	1
7	94144	. PIVOT - LATCH	1	17	91245	. WASHER - THRUST	1
8	93081	. BAND - BRAKE	1				
9	93082	. PIN - BAND ANCHOR	1				

FAN HOUSING and STARTER ASSEMBLY

Figure 3

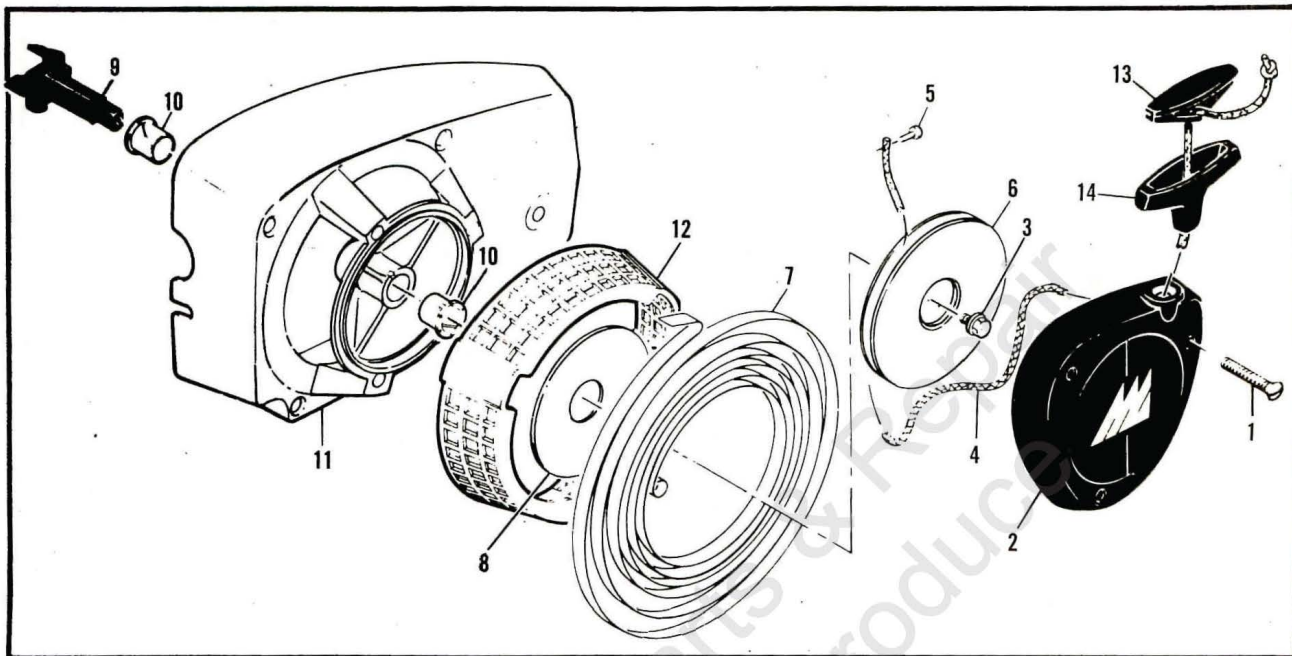

FIGURE 3 FAN HOUSING and STARTER ASSEMBLY

ITEM NO.	PART NUMBER	DESCRIPTION	UNITS PER ASY.
	216050	Fan Housing and Starter Asy	1
1	110646	. Screw-Oval 8-32 x 1 1/8	3
2	91084	. Cover-Starter	1
3	110928	. Screw-Hx hd 10-24 x 1/2	1
4	68162	. Rope-Starter	1
5	110470	. Rivet-Rope	1
6	85122	. Drum-Starter	1
7	87680	. Spring-Rewind	1

ITEM NO.	PART NUMBER	DESCRIPTION	UNITS PER ASY.
8	86053	. Shield-Spring	1
9	83748	. Shaft-Starter	1
10	57535	. Bushing-Starter	2
11	216051	. Kit-Fan Housing	1
12	214192	. Guard-Sawdust	1
13	214699	Insert-Starter	1
14	93137	Handle-Starter	1

ACCESSORIES

PART NUMBER	DESCRIPTION
-94121	Case-Carrying (16" Bar Guard)
92896	Guard - Bar 16"
86419	Guide - Timing
69191	Kit - Pressure Test Adaptor
84453	Kit - Piston Tool
-214221	Srench

PART NUMBER	DESCRIPTION
84922	Kit - Spark Arrester Screen
214223	Spark - Plug (Standard)
63432	Spark Plug (Cooler)
216063	Key - Socket 5/32
216147	Key - Socket 1/8
216335	Key - Socket 3/32

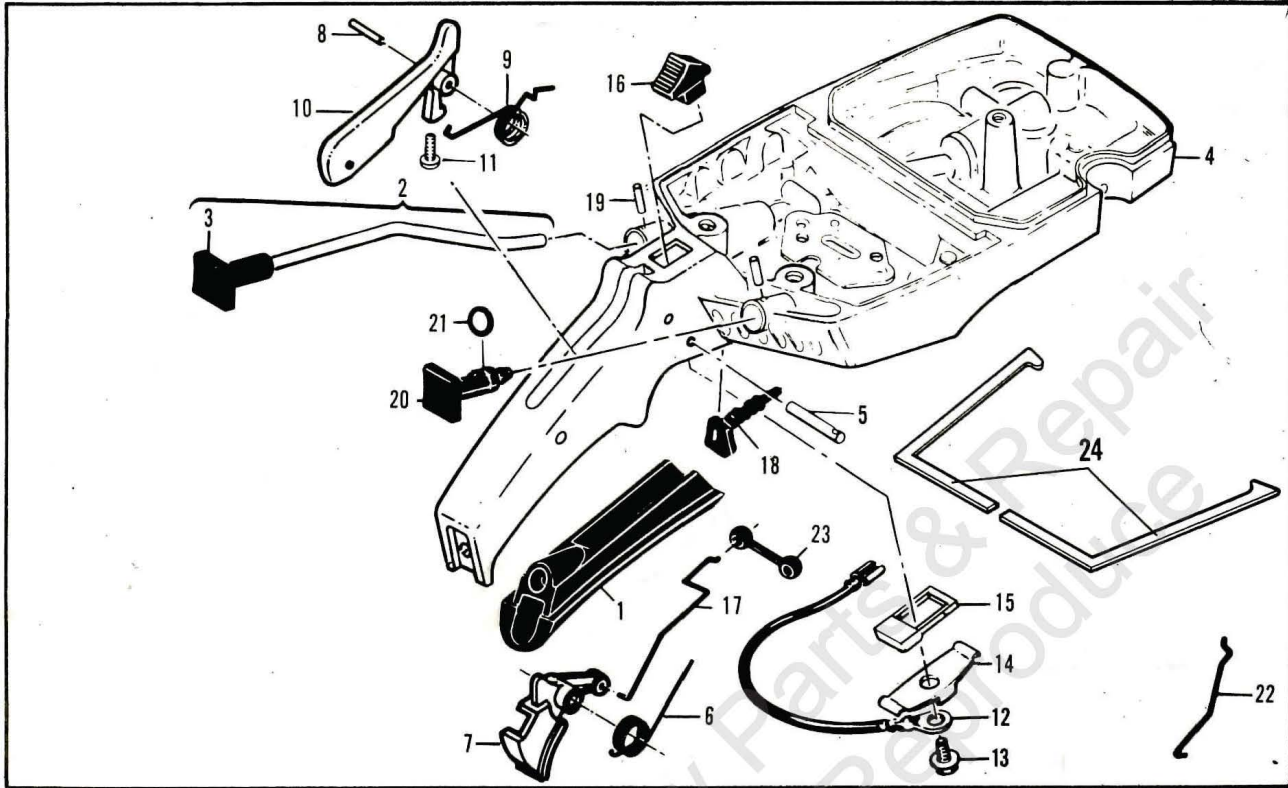

FIGURE 4 FUEL TANK ASSEMBLY

ITEM NO.	PART NUMBER	DESCRIPTION	UNITS PER ASY.
1	89320	Insert-Handle Grip	1
2	216126	Button and Rod Assembly	1
3	95615	. Button-Oiler	1
4	-216127	Kit-Fuel Tank/Control	1
5	110378	. Pin-Roll 3/16 x 15/16	1
6	92152	. Spring-Trigger	1
7	214679	. Trigger-Throttle	1
8	105654	. Pin-Roll 1/8 x 7/8	1
9	92154	. Spring-Trigger Release	1
10	-214680	. Release-Trigger	1
11	-110713	. Screw-SKT HD 10-24 x .88	1
12	214692	. Wire Assembly-Stop Switch	1

ITEM NO.	PART NUMBER	DESCRIPTION	UNITS PER ASY.
13	111012	Screw-PN HD 4-40 x .31	1
14	62451	Control-Switch	1
15	214691	Base-Switch	1
16	68846	Button-Switch	1
17	85107	Rod-Throttle	1
18	214701	Seal-Throttle Rod	1
19	105673	Pin-Roll 3/32 x 9/16	2
20	69041	Button-Choke	1
21	105614	"O" Ring	1
22	69042	Rod-Choke	1
23	69043	Snubber-Rod	1
24	-219280	Gasket - Kit	1

CARBURETOR ASSEMBLY Figure 5

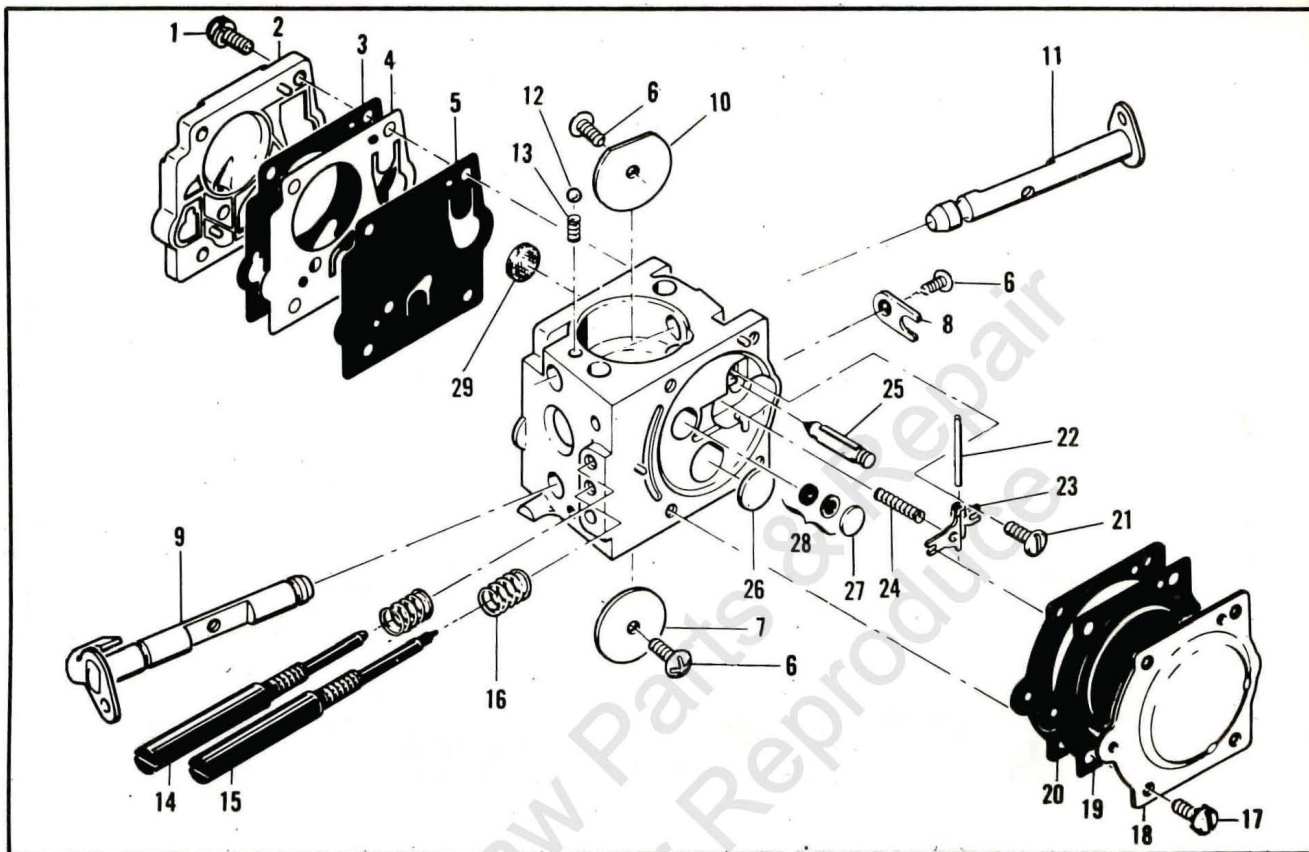

FIGURE 5 CARBURETOR ASSEMBLY

ITEM NO.	PART NUMBER	DESCRIPTION	UNITS PER ASY.
	1761 87666	CARBURETOR ASSEMBLY (WALBRO)	1
1	---	. SCREW - PUMP COVER	4
2	---	. COVER - PUMP	1
3	---	. GASKET - COVER	1
4	--- ① ②	. DIAPHRAGM - CHECK VALVE	1
5	--- ① ②	. DIAPHRAGM - FUEL PUMP	1
6	---	. SCREW - PLATE	3
7	---	. PLATE - THROTTLE	1
8	---	. CLIP - SHAFT	1
9	---	. SHAFT ASSEMBLY - THROTTLE	1
10	---	. PLATE - CHOKE	1
11	---	. SHAFT ASSEMBLY - CHOKE	1
12	--- ①	. BALL - CHOKE FRICTION	1
13	--- ①	. SPRING - CHOKE	1
14	--- ①	. NEEDLE - HIGH SPEED	1
15	--- ①	. NEEDLE - IDLE	1

ITEM NO.	PART NUMBER	DESCRIPTION	UNITS PER ASY.
16	--- ①	. SPRING - NEEDLE	2
17	---	. SCREW - DIAPHRAGM COVER	4
18	---	. COVER - DIAPHRAGM	1
19	--- ① ②	. DIAPHRAGM - METERING	1
20	--- ①	. GASKET - DIAPHRAGM	1
21	--- ① ②	. SCREW - LEVER PIN	1
22	--- ① ②	. LEVER - METERING	1
23	--- ① ②	. SPRING - LEVER	1
24	--- ① ②	. SPRING - LEVER	1
25	--- ① ②	. VALVE - NEEDLE	1
26	--- ① ②	. PLUG - 3/8	1
27	--- ① ②	. PLUG - 5/16	1
28	--- ① ②	. KIT VALVE & SEAT ASSEMBLY	1
29	--- ① ②	. SCREEN - FUEL	1

① Contained in Major Repair Kit, P/N 217080.

② Contained in Minor Repair Kit, P/N 217078.

Figure 6

POWERHEAD ASSEMBLY

PRO MAC™ 10-10S

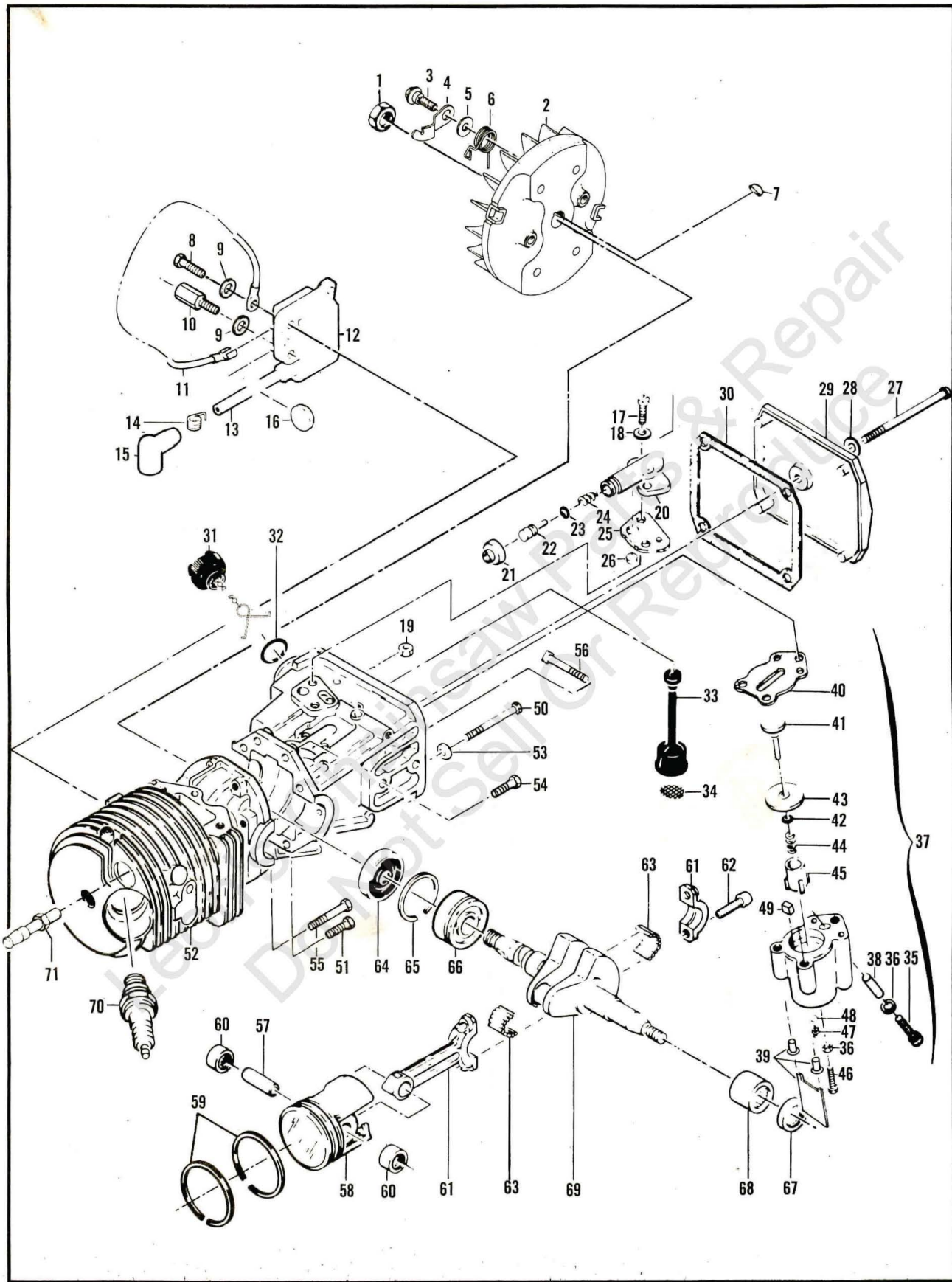

FIGURE 6 POWERHEAD ASSEMBLY

ITEM NO.	PART NUMBER	DESCRIPTION	UNITS PER ASY.	ITEM NO.	PART NUMBER	DESCRIPTION	UNITS PER ASY.
1	110703	Nut-Hx 3/8-24	1	37	215339	Pump Assembly-Pulse	1
2	216739	Flywheel Assembly	1	38	91774	. Sleeve	1
3	93464	. Screw-Pawl Pivot	2	39	215246	. Kit-Oil pump clip	1
4	93198	. Pawl-Starter	2	40	92818	. . Seal-Pulse pump	1
5	93469	. Washer-Pawl	2	41	214278	. Piston Assembly-Pump	1
6	214102	. Spring-Starter Pawl	2	42	105603	. "O" Ring	1
7	100106	Key-Woodruff	1	43	86182	. Ring-Piston	1
8	110127	Screw-Hx hd 10-24 x 7/8 SEMS	1	44	60259	. Spring-Piston	1
9	100002	Washer-#10	2	45	62227	. Sleeve-Adjustment	1
10	83512	Stud-Special	1	46	110386	. Screw-Hx hd 8-32 x 1	1
11	-84686-01	Wire Assembly-Ground	1	47	92844	. Spring-Outlet valve	1
12	95553	Electronic Ignition Assembly	1	48	-- --	. Ball	1
13	95269	. Wire Assembly-Spark plug	1	49	91259	. Pad-Pump	1
14	102556	. . Connector	1	50	62106	Screw-Sealing	4
15	95266	. . Boot	1	51	110288	Screw-Hx hd 8-32 x 3/4	1
16	110995	. Grommet	1	52	214672	Cylinder/Crankcase Assembly	1
17	110338	Screw-Fil 8-32 x 9/16	2	53	111025	. Washer-Sealing	4
18	110613	Washer-#8	2	54	110288	. Screw-Hx hd 8-32 x 3/4	2
19	100955	Nut-Hx 8-32	1	55	110618	. Screw-Hx hd 8-32 x 1 3/8	1
20	84156	Housing-Pump	1	56	62065	. Bolt-Bar mounting	2
21	215151	Cap-Housing	1	57	87710	Pin-Piston	1
22	62266	Plunger-Pump	1	58	89783-01	Piston Assembly	1
23	105614	"O" Ring	1	59	92517	. Ring Set-Piston	1
24	66687	Spring-Pump	1	60	-111021	. Bearing-Needle-	2
25	91669	Gasket-Pump	1	61	85352	Connecting Rod Assembly	1
26	91668	Valve-Pump	1	62	61627-01	. Screw-Skt special	2
27	110291	Screw-Pn hd 10-24 x 2 5/8	1	63	63225	. Roller-Needle (set of 20)	1
28	110921	Washer-Sealing	1	64	67906	Seal-Oil	1
29	-218707	Cover-Oil tank	1	65	63464	Ring-Snap	1
30	86306	Gasket-Cover	1	66	67905	Bearing-Ball	1
31	216053	Cap-Oil tank	1	67	110260	Seal-Oil	1
32	101148	"O" Ring	1	68	104357	Bearing-Needle	1
33	91672	Hose Assembly-Oil	1	69	216910	Kit-Crankshaft	1
34	51506	. Screen-Hose	1	70	62345 ②	Spark Plug	1
35	110890	Screw-Fil 10-24 x 7/8	1	70	92879 ①	Spark Plug	1
36	100003	Washer-#10	1	71	94272	Valve-Compression Release	1

① Used on modelos with suffix number -03.

② Used on models with suffix numbers -02, -04, -05, -06.

BAR and CHAIN COMBINATIONS

PART NUMBER	DESCRIPTION
94074	Bar-16" Speed Mac
89502	Bar-16" Mac 10
-88167-12	Chain 16" PM 370GX 60CL
-218839-12	Chain 16" PGR 370GLX 60CL
89974-14	Chain-16" SPR 370G
93778	Bar-20" Speed Mac
89503	Bar-20" Mac 10
-88173-12	Chain 20" PM 370GLX 71CL
-218069-12	Chain 20" PGR 370GLX 70CL
-89979-12	Chain 20" SPR 370GX 71CL

PART NUMBER	DESCRIPTION
86846	Bar-24" Speed Mac
89504	Bar-24" Mac 10
-88175-14	Chain 24" PM 370G 81CL
218070-14	Chain 24" PGR 370G 81CL
-89981-12	Chain 24" SPR 370GX 81CL
86847	Bar-28" Speed Mac
89505	Bar-28" Mac 10
-93552-14	Chain 28" PM 370G 93CL
-89984-12	Chain 28" SPR 370GX 92CL

McCULLOCH
CORPORATION

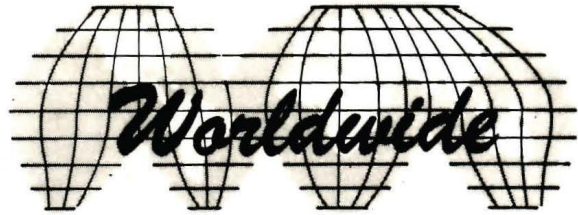

● MANUFACTURING ● SALES ● SERVICE ●

McCULLOCH
CORPORATION

900 LAKE HAVASU AVE.
LAKE HAVASU CITY, AZ 86403-2891

FOR SERVICE-RELATED PROBLEMS,
REPAIR OR MAINTENANCE
TAKE YOUR UNIT TO THE NEAREST
AUTHORIZED McCULLOCH SERVICING
DEALER LISTED UNDER SAWS IN YOUR
TELEPHONE DIRECTORY YELLOW PAGES.

If additional assistance is required, call this toll-free hot-line:
(800) 423-6302

Arizona residents call collect (602) 453-3681

Leon's Chair & Repair
Do Not Sell My Products