

ILLUSTRATED PARTS LIST

MODELS	SERIAL NUMBER PREFIX	MODELS	SERIAL NUMBER PREFIX
600014A	11-, 12-	600014F	12-
600014B	11-, 12-	600014G	12-
600014C	11-, 12-	600014K	11-, 12-
600014E	11-, 12-	600014U	11-, 12-

McCulloch chain saws are identified by a model number (in this instance, 600014) followed by a suffix letter (A, B, C, etc.) stamped on the identification plate attached to the saw. Suffix letters denote variations in parts or assemblies in the manufacture of the saw.

Part numbers listed in this I.P.L. which have a suffix letter or letters following the description, indicate the part is used only on the model(s) identified by the letter or letters.

Part numbers and descriptions without suffix letter or letters apply to all versions of the chain saw model.

Part numbers which have one or more dots (.) preceding their descriptions may be ordered individually, but they are also included in the kit or assembly whose description begins directly above the dot(s).

Part numbers in this IPL which were not in the previous IPL covering these saws, are indicated by a dash (-) preceding the new part number.

The policy of McCulloch is one of continual improvement in design, manufacturing and engineering advancement wherever possible to assure still finer two-cycle power tools. Hence, specifications, equipment, colors, design and manufacturer's suggested list prices are subject to change without notice and McCulloch reserves the right to make such changes without prior notification or obligation to backfit or supply backfit components for units previously shipped from the factory.

PRO MAC 10-10 CHAIN SAW



January 1983

- CONTENTS -

	Page
Figure 1. General	2
Figure 2. CHAIN BRAKE Assembly	4
Figure 3. Fan Housing & Starter Asys	4
Figure 4. Carburetor Assembly	6
Figure 5. Carburetor Assembly	6
Figure 6. Fuel Tank Assembly	8
Figure 7. Powerhead Assembly	10
Accessories	9
Service Specifications	9



PRO MAC 10-10

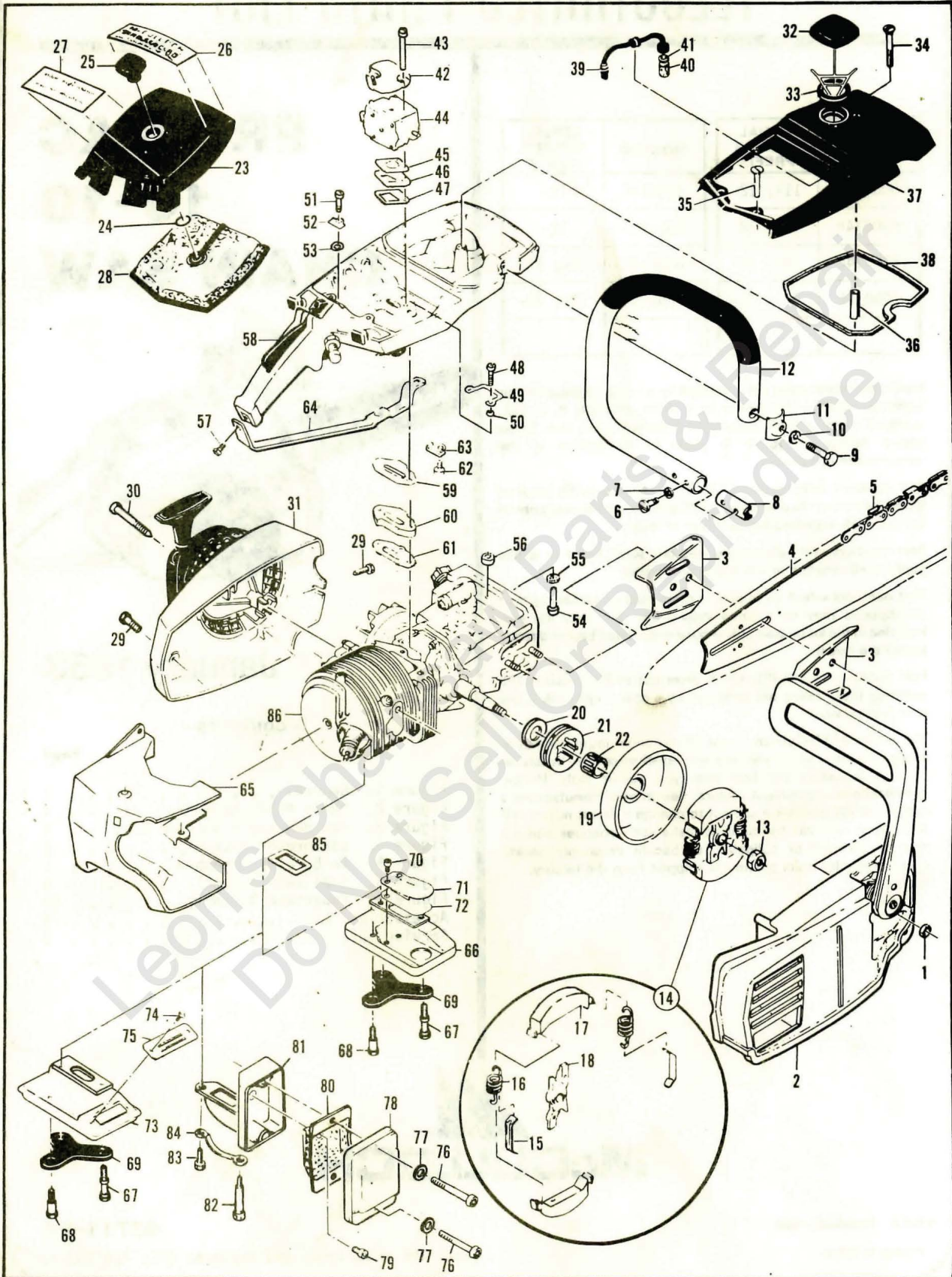

Figure 1. General

Figure 1. General

ITEM NO.	PART NUMBER	DESCRIPTION	UNITS PER ASY.	ITEM NO.	PART NUMBER	DESCRIPTION	UNITS PER ASY.
1	110961	Nut-Hx 5/16-24	2	43	103357	Screw-Hx hd 10-24 x 2 1/8	1
2		CHAIN BRAKE Asy (Figure 2)		44		Carburetor Asy (Figure 4, 5)	
3	64330	Set-Bar plates	1	45	86189	Gasket-Carburetor	1
4	214237	Bar-16" Sprocket Nose	1	46	84078	Spacer-Carburetor	1
5	88167N	Chain Assembly-16" PM 370G	1	47	84081	Gasket-Spacer	1
6	110865	Screw-Hx hd 10-24 x 7/8	2	48	110570	Screw-Hx hd 12-24 x 1-3/8	2
7	100352	Washer-#10	2	49	68582	Plate-Lock	1
8	89727	Retainer-Frame	1	50	102115	Washer-#12	2
9	102130	Screw-Hx hd 1/4-20 x 1-1/2	1	51	110568	Screw-Hx hd 12-24 x 1-1/8	1
10	100153	Washer-Lock 1/4	1	52	69516	Plate-Lock	1
11	63484	Clamp-Frame	1	53	64856	Washer-Special	1
12	214549	Frame & Grip Assembly	1	54	110713	Screw-Skt hd 10-24 x 7/8	1
13	86113	Nut-Hx 3/8-24 (L.H.)	1	55	100003	Washer-#10	1
14	214301	Clutch Assembly	1	56	69772	Spacer-Fuel tank	1
15	64583	. Retainer-Spring	2	57	110910	Screw-Hx hd 10-24 x 1-3/8	1
16	83223	. Spring-Clutch	2	58		Fuel Tank Assembly (Figure 6)	
17	67233	. Kit-Clutch shoe	1	59	84082	Gasket-Fuel tank	1
18	214300	. Rotor Assembly		60	84079	Insulator-Fuel tank	1
19	95166	Drum/Sprocket Assembly (A)	1	61	84082	Gasket-Insulator	1
20	86958	. Washer-Shim (A)	1	62	110566	Screw-Hx hd 12-24 x 5/8	1
21	86145	. Kit-Sprocket (A)	1	63	68508	Plate-Lock	1
19	214979	① Drum/Sprocket Assembly-Spur	1	64	85007	Brace-Handle	1
20	86958	① Washer-Shim	1	65	214702	Shroud	1
19	95165	① Drum/Sprocket Asy (B,C,E,F,G, K,U)		66	68863	Kit-Muffler (A,B,G)	1
20	86958	① . Washer-Shim (B,C,E,F,G,K,U)	1	67	67838	② . Screw-Muffler, long	2
21	-86951	① . Kit-Spkt (B,C,E,F,G,K,U)	1	68	67837	② . Screw-Short	1
22	-215720	Kit-Bearing-Washer	1	69	83993	② . Plate-Lock	1
23	214674	Cover Assembly-Air cleaner	1	70	110563	. Screw-Skt hd 8-32 x 1/4 (A,B,G)	2
24	110565	. Ring-Retainer	1	71	84780	. Stop-Reed (A,B,G)	1
25	68529	. Knob-Cover	1	72	84779	. Reed (A,B,G)	1
26	93266	Plate-Name	1	73	95318	③ Kit-Muffler	1
27	91548	Plate-Instruction	1	74	110662	③ . Screw-Pan hd 6-32 x 3/8	2
28	92420	Filter-Air	1	75	95320	③ . Kit-Muffler cover	1
29	110741	Screw-Pan hd 10-24 x 1/2	2		93992	Kit-Muffler (E)	1
30	87871	Screw-Special	3	76	101563	. Screw-Skt hd 10-24 x 1-1/4 (E)	2
31		Fan Housing & Starter Asys (Fig.3)		77	110264	. Washer (E)	2
32	-216053	Cap Assembly-Fuel	1	78	83966	. Cover Asy-Muffler (E)	1
33	69767	. Gasket	1	79	110928	. Screw-Hx hd 10-24 x 1/2(E)	1
34	110402	Screw-Oval hd 12-24 x 2-3/8	1	80	85152	. Baffle (E)	1
35	101986	Screw-Oval hd 10-24 x 1	2	81	83105	. Kit-Body & Duct (E)	1
36	87840	Spacer	1	82	68187	. . Screw-Special (E)	1
37	69679	Cover-Fuel tank	1	83	110529	. Screw-Hx hd 10-24 x 1/2 (E)	1
38	69345	Gasket-Cover	1	84	67922	. Lockplate (E)	1
39	-215708	Hose Assembly-Fuel	1	85	84007	Gasket-Muffler	1
40	63932	. Filter-Fuel	1	86		Powerhead Assembly (Figure 7)	
41	100440	. Washer	1				
42	69952	Bracket-Air cleaner	1				

① One of two types of sprocket/drum assemblies used on models with serial number prefix 12-, suffix letter "U". Identify parts before ordering.

② Used on models with model number suffix letter A, B, C, F, G, K, U.

③ Used on models with model number suffix letter C, F, K, U.

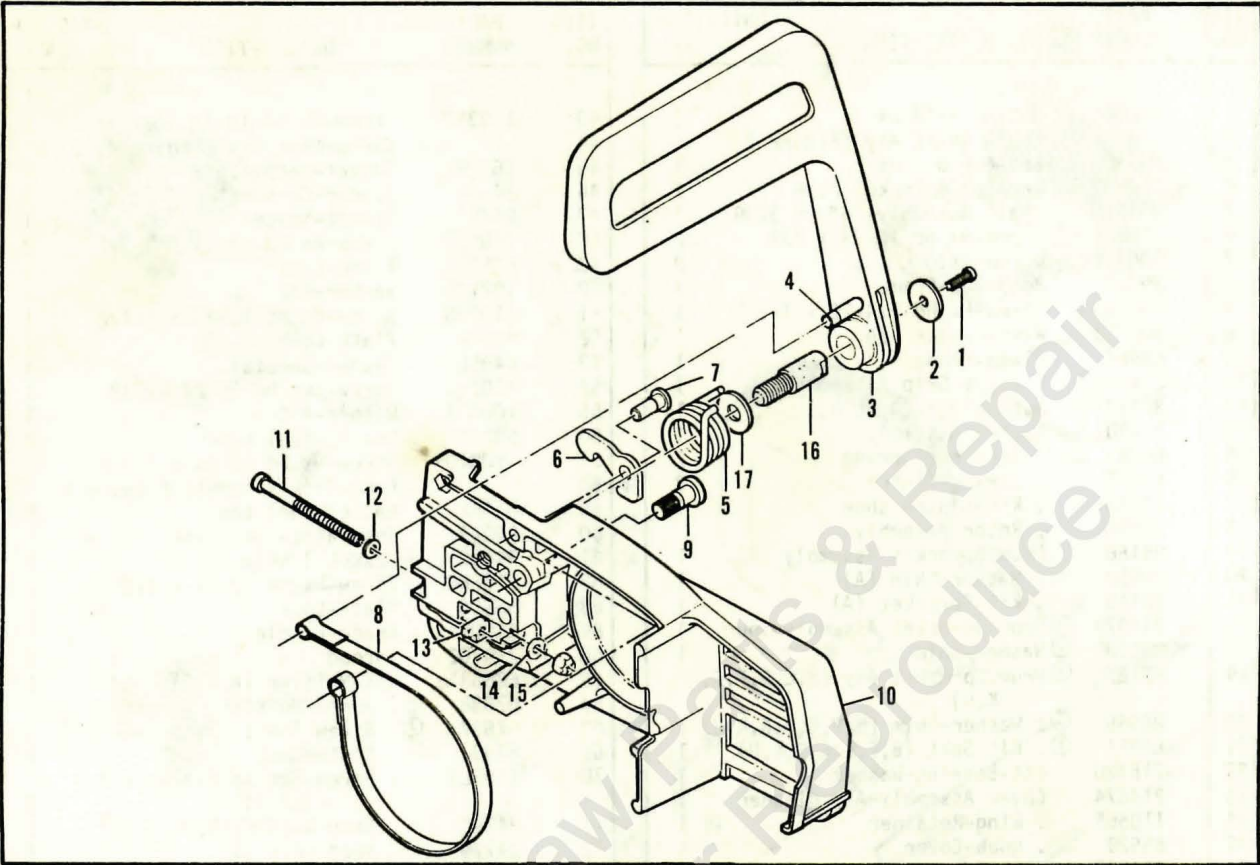

Figure 2. CHAIN BRAKE Assembly

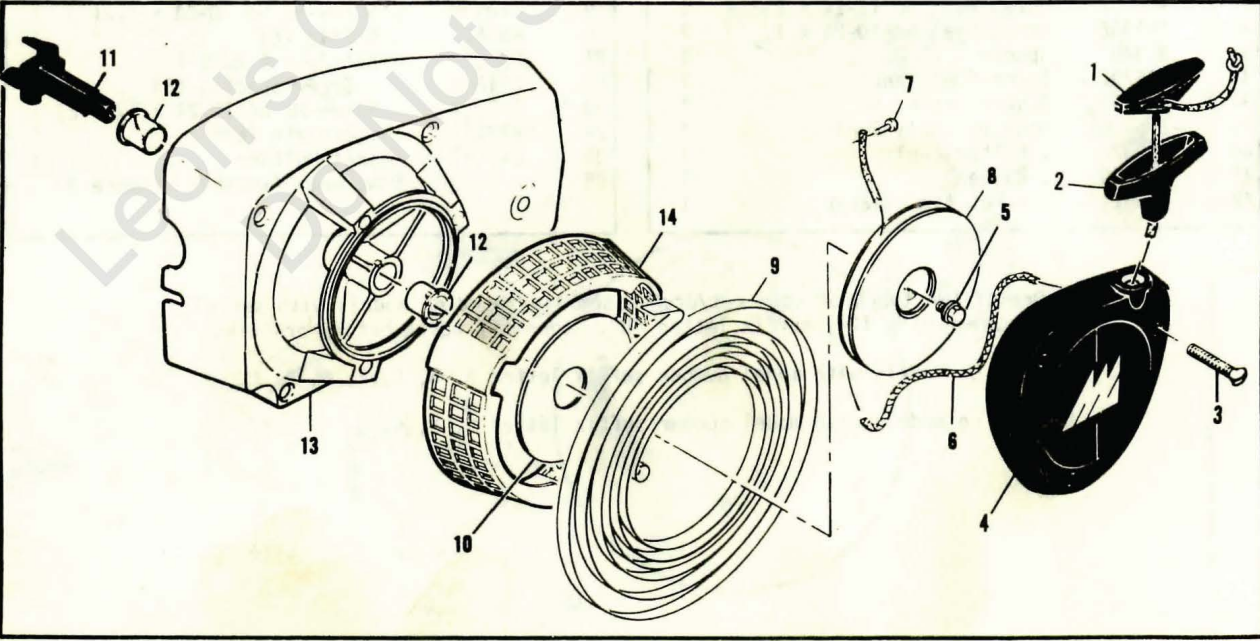

Figure 3. Fan Housing & Starter Assemblies

Figure 2. CHAIN BRAKE Assembly

ITEM NO.	PART NUMBER	DESCRIPTION	UNITS PER ASY.
	-216003	Kit-CHAIN BRAKE	1
1	102500	. Screw-Pan hd 10-24 x 1/2	1
2	91273	. Washer-Special	1
3	-215911	. Lever Asy	1
4	214366	. . Pin Asy-Roller	1
5	93085	. Spring-Brake	1
6	93083	. Latch	1
7	93669	. Pivot-Latch	1
8	93081	. Band-Brake	1
9	93082	. Pin-Band Anchor	1
10	214668	. Housing-Brake (A,B,G)	1

ITEM NO.	PART NUMBER	DESCRIPTION	UNITS PER ASY.
10	214669	. Housing-Brake (C,E,F,K,U)	1
11	110527	. . Screw-Fil hd 10-24 x 2-3/4	1
12	110264	. . Washer-#10	1
13	61705	. . Nut-Bar adjusting	1
14	100002	. . Washer-#10	1
15	102067	. . Nut-Hx 10-24	1
16	91246	. . Pin-Lever pivot	1
17	91245	. . Washer-Thrust	1

Figure 3. Fan Housing & Starter Assembly

ITEM NO.	PART NUMBER	DESCRIPTION	UNITS PER ASY.
	87667	Fan Housing & Starter Asy	1
1	214699	. Insert-Starter	1
2	93137	. Handle-Starter	1
3	110646	. Screw-Oval hd 8-32 x 1-1/8	3
4	91084	. Cover-Starter	1
5	-110928	. Screw-Hx hd 10-24 x 1/2	1
6	68162	. Rope-Starter	1
7	110470	. Rivet-Rope	1

ITEM NO.	PART NUMBER	DESCRIPTION	UNITS PER ASY.
8	85122	. Drum-Starter	1
9	87680	. Spring-Rewind	1
10	86053	. Shield-Spring	1
11	83748	. Shaft-Starter	1
12	57535	. Bushing-Starter	2
13	87693	. Kit-Fan Housing	1
14	214192	. . Guard-Sawdust	1

Leon's Chainsaws & Repairs
Do Not Sell

PRO MAC 10-10

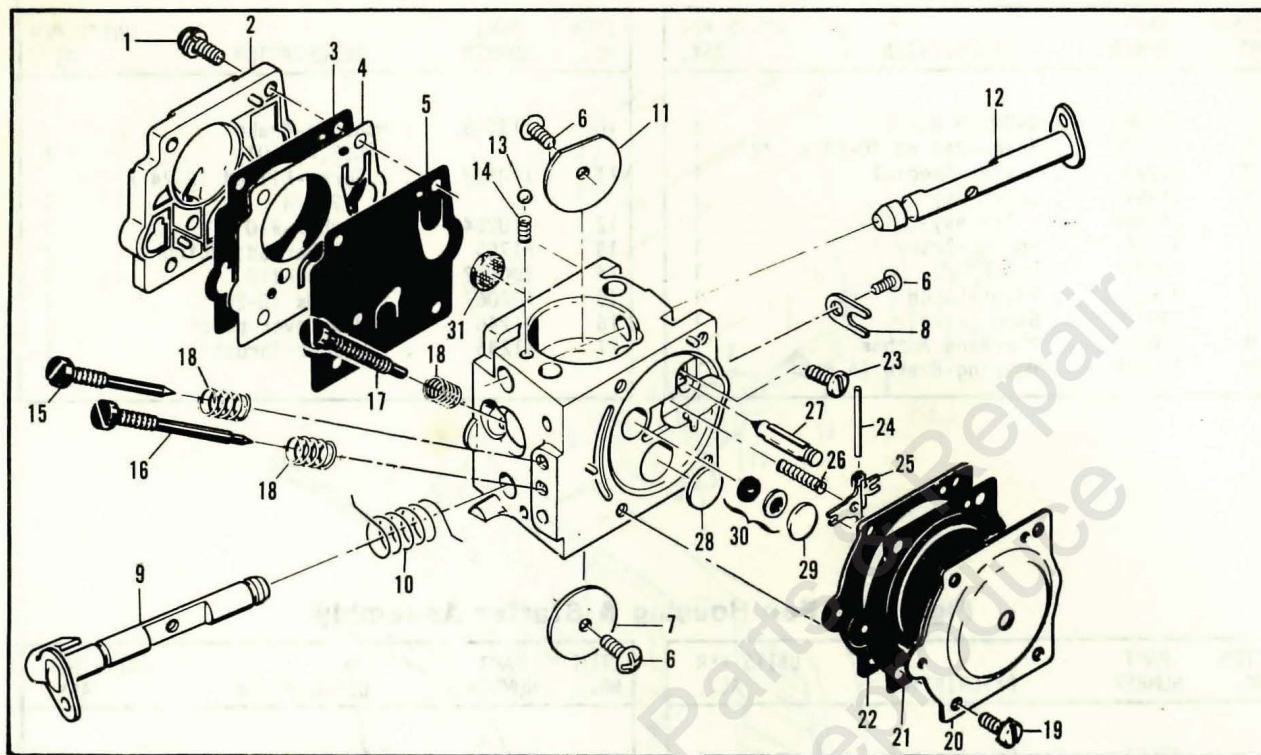

Figure 4. Carburetor Assembly

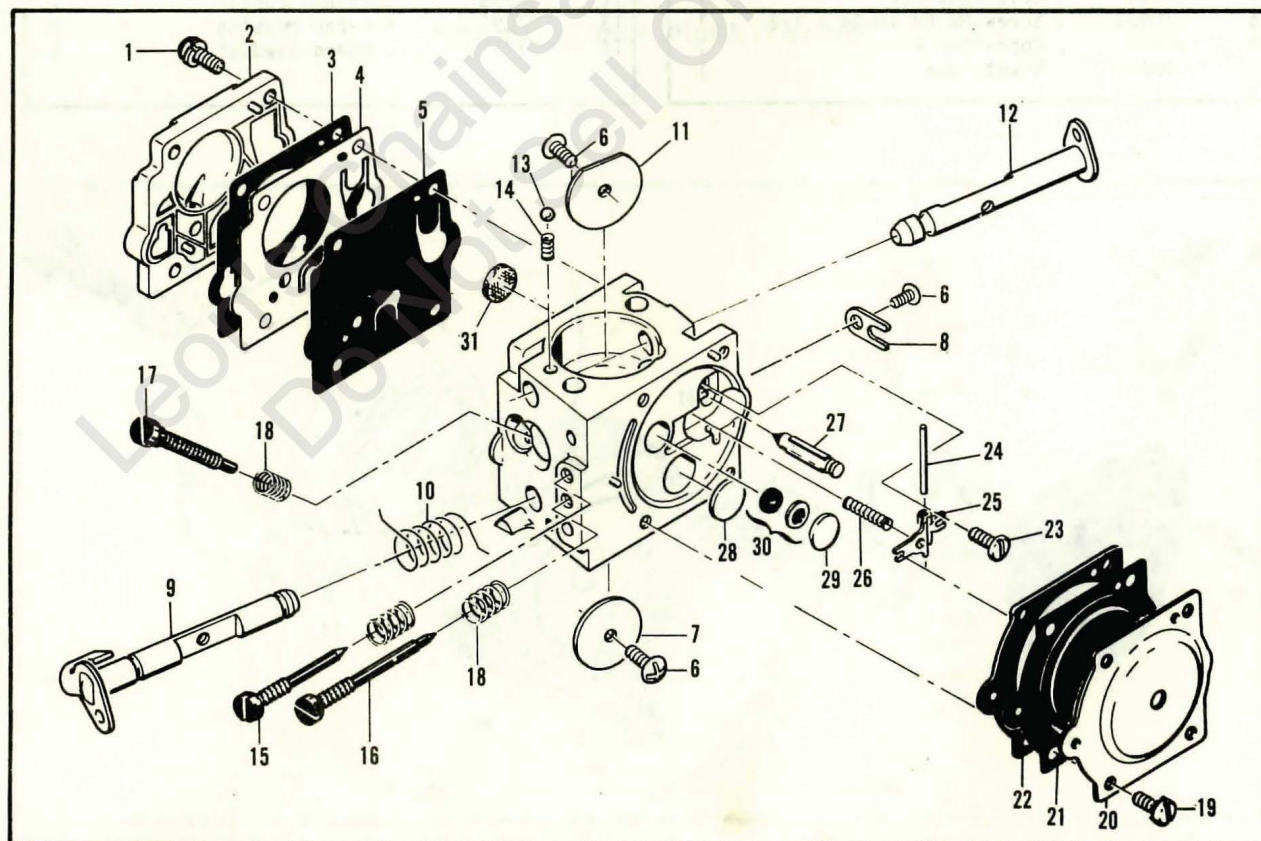

Figure 5. Carburetor Assembly

Figure 4. Carburetor Assembly

ITEM NO.	PART NUMBER	DESCRIPTION	UNITS PER ASY.	ITEM NO.	PART NUMBER	DESCRIPTION	UNITS PER ASY.
	92654	① Carburetor-Walbro SDC 65	1	16	92924	④ Needle-Idle	1
1	-	. Screw-Pump cover	4	17	68106	④ Screw-Idle speed	1
2	-	. Cover-Pump	1	18	67502	④ Spring-Needle	3
3	67495	②③ Gasket-Cover	1	19	-	. Screw-Diaphragm cover	4
4	67498	②③ Diaphragm-Check valve	1	20	-	. Cover-Diaphragm	1
5	83114	②③ Diaphragm-Fuel pump	1	21	67499	②③ Diaphragm-Metering	1
6	-	. Screw-Plate	3	22	67496	②③ Gasket-Diaphragm	1
7	-	. Plate-Throttle	1	23	67500	③ Screw-Lever pin	1
8	-	. Clip-Shaft	1	24	67508	③ Pin-Lever	1
9	-	. Shaft Asy-Throttle	1	25	67509	③ Lever-Metering	1
10	-	. Spring-Throttle shaft	1	26	67503	③ Spring-Lever	1
11	-	. Plate-Choke	1	27	67491	③ Valve-Needle	1
12	-	. Shaft Asy-Choke	1	28	71690	③ Plug-3/8	1
13	-	. Ball-Choke friction	1	29	69506	③ Plug-5/16	1
14	-	. Spring-Choke friction	1	30	83758	③ Kit-Valve & Seat Asy	1
15	92937	④ Needle-High speed	1	31	67507	③ Screen-Fuel	1

- ① This is one of two carburetors used alternately on the PM 10-10. Before ordering parts, identify the carburetor on the saw.
- ② Contained in Repair Kit, P/N -216718.
- ③ Contained in Gasket/Diaphragm Kit, P/N -216729.
- ④ Contained in Needle Kit, P/N -216735.

NOTE: Items not listed with part numbers are shown for identification and disassembly sequence purposes only. They are NOT available as service parts.

Figure 5. Carburetor Assembly

ITEM NO.	PART NUMBER	DESCRIPTION	UNITS PER ASY.	ITEM NO.	PART NUMBER	DESCRIPTION	UNITS PER ASY.
	85720	① Carburetor-Walbro SDC 37A	1	17	68106	. Screw-Idle speed	1
1	67501	. Screw-Pump cover	4	18	*67502	. Spring-Needle	3
2	83760	. Cover-Pump	1	19	70798	. Screw- Diaphragm cover	4
3	*67495	. Gasket-Cover	1	20	83761	. Cover-Diaphragm	1
4	*67498	. Diaphragm-Check valve	1	21	*67499	. Diaphragm-Metering	1
5	*83114	. Diaphragm-Fuel pump	1	22	*67496	. Gasket-Diaphragm	1
6	*47690	. Screw-Plate	3	23	*67500	. Screw-Lever pin	1
7	83762	. Plate-Throttle	1	24	*67508	. Pin-Lever	1
8	67489	. Clip-Shaft	1	25	*67509	. Lever-Metering	1
9	67486	. Shaft Asy-Throttle	1	26	*67503	. Spring-Lever	1
10	*85981	. Spring-Throttle shaft	1	27	*67491	. Valve-Needle	1
11	67490	. Plate-Choke	1	28	*71690	. Plug-3/8	1
12	67488	. Shaft Asy-Choke	1	29	*69506	. Plug-5/16	1
13	*100302	. Ball-Choke friction	1	30	83758	. Kit-Valve & Seat Asy	1
14	*67504	. Spring-Choke friction	1	31	*67507	. Screen-Fuel	1
15	*68104	. Needle-High speed	1		*67482	Gasket Set	
16	*68105	. Needle-Idle	1		83764	Repair Kit	

- *Indicates parts included in Repair Kit, P/N 83764.
- ① This is one of two carburetors used alternately on the PM 10-10. Before ordering parts, identify the carburetor on the saw.

PRO MAC 10-10

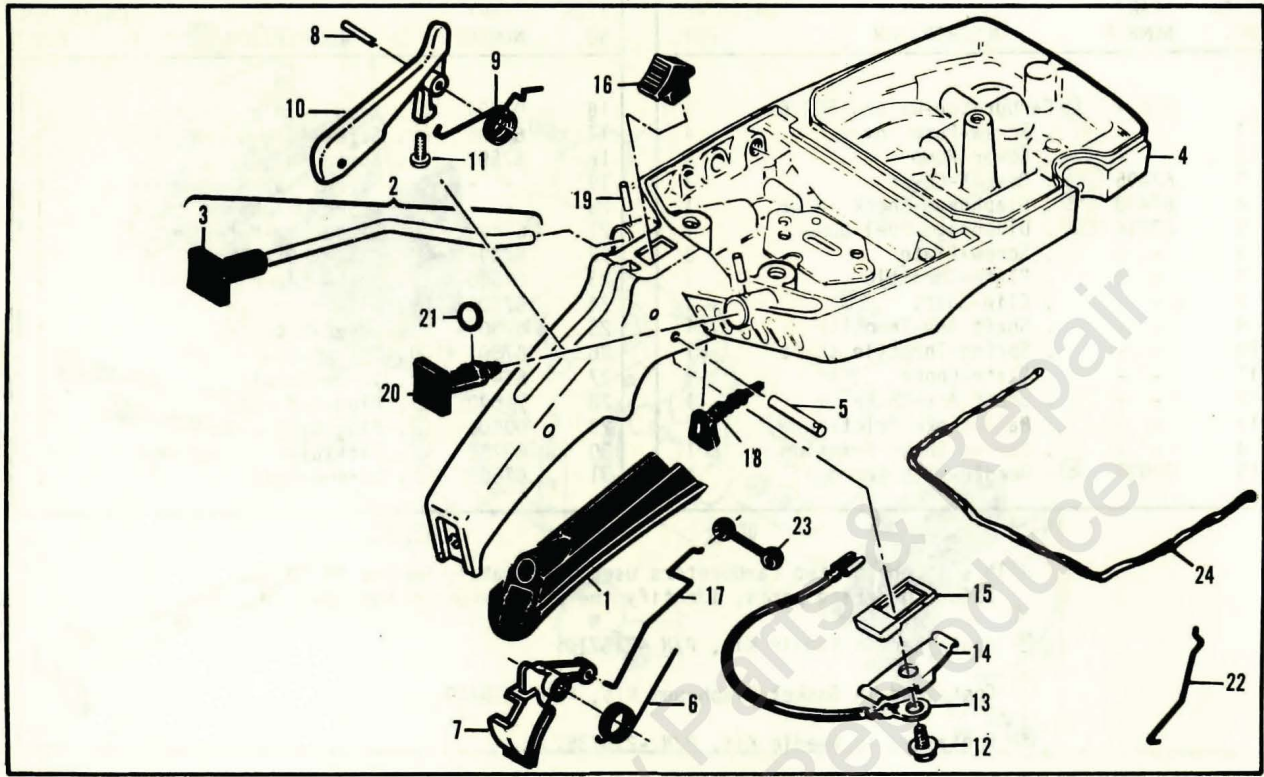

Figure 6. Fuel Tank Assembly

Figure 6. Fuel Tank Assembly

ITEM NO.	PART NUMBER	DESCRIPTION	UNITS PER ASY.
1	89320	Insert-Handle grip	1
2	-216126	Button & Rod Assembly	1
3	95480	. Button-Oiler	1
4	214705	Kit-Fuel tank/control	1
5	110378	. Pin-Roll 3/16 x 15/16	1
6	92152	. Spring-Trigger	1
7	214679	. Trigger-Throttle	1
8	105654	. Pin-Roll 1/8 x 7/8	1
9	92154	. Spring-Trigger release	1
10	94275	. Release Asy-Trigger	1
11	111012	. . Screw-Pan hd 4-40 x 5/16	1
12	110706	. Screw-Fil hd 8-18 x 1/2	1

ITEM NO.	PART NUMBER	DESCRIPTION	UNITS PER ASY.
13	214692	. Wire Asy-Stop switch	1
14	62451	. Contact-Switch	1
15	214691	. Base-Switch	1
16	68846	. Button-Switch	1
17	85107	Rod-Throttle	1
18	214701	Seal-Throttle rod	1
19	105673	Pin-Roll 3/32 x 9/16	2
20	69041	Button-Choke	1
21	105614	"O" Ring	1
22	69042	Rod-Choke	1
23	69043	Snubber-Rod	1
24	69564	① Seal-Airbox	1

①Furnished on a 12-1/2 inch strip containing 9 beads (enough for 9 replacement).

Accessories

ITEM NO.	PART NUMBER	DESCRIPTION	UNITS PER ASY.
	214238	Bar-20" Sprocket Nose (G)	
	89978N	Chain Asy-20" SPR 370G (G)	
	93285	Case-Carrying (16" Bar Guard)	
	92896	Guard-Bar 16"	
	69210	Piston Asy-.020 in. oversize	
	- -	. Ring Set-Piston .020 in. oversize	
	69211	Piston Asy-.030 in. oversize	
	62812	. Ring Set-Piston .030 in. oversize	
	86419	① Guide-Timing	

ITEM NO.	PART NUMBER	DESCRIPTION	UNITS PER ASY.
	69191	Kit-Pressure Test Adaptor	
	84453	Kit-Piston Tool	
	83235	Scrench	
	89431	Kit-Spark Arrester Screen	
	214223	Spark Plug (Standard)	
	63432	Spark Plug (Cooler)	
	91967	Kit-Spike	
	102388	. Screw-Hx hd 10-24 x 5/8	
	24236	. Washer Special	
	101191	. Nut-Hx 10-24	

①Used on models with serial number prefix 11-.

Service Specifications

Spark Plug Gap	.025 inch (.63 mm)
*Lamination Gap	.010 to .012 inch (.25 to .30 mm)
**Lamination Gap	.011 to .015 inch (.30 to .40 mm)
*Breaker Point Gap	.019 to .020 inch (.48 to .51 mm)
Timing	26° BTDC
Clutch Engagement Speed	2800 to 3000 R.P.M.
Torques	Connecting Rod Screws: 65 to 70 pound x inches (8.5 to 9.2 N.m)
	Clutch Nut: 160 to 170 pound x inches (18 to 19 N.m)
	Flywheel Nut: 265 to 325 pound x inches (30 to 37 N.m)

*These specifications for models with serial number prefix 11-.

**These specifications for models with serial number prefix 12-.

PRO MAC 10-10

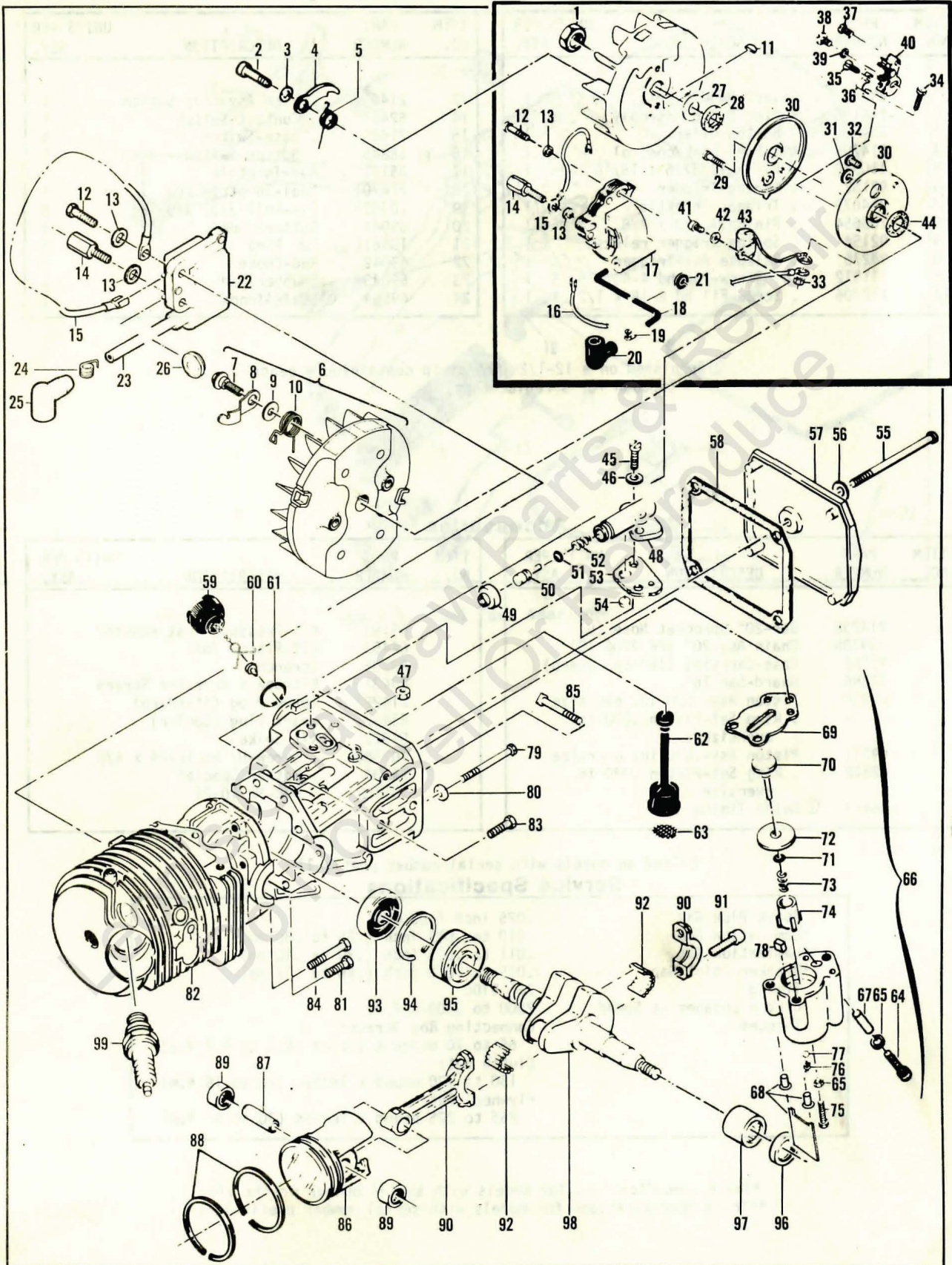

Figure 7. Powerhead Assembly

Figure 7. Powerhead Assembly

ITEM NO.	PART NUMBER	DESCRIPTION	UNITS PER ASY.
1	110703	Nut-Hx 3/8-24	1
2	88804 ①	Screw-Pawl Pivot	1
3	83241 ①	Washer-Special	2
4	67546 ①	Pawl-Starter	2
5	67545 ①	Spring-Pawl	2
6	-216739 ②	Kit-Flywheel/Pawl	1
7	93464 ②	. Screw-Pawl	2
8	93198 ②	. Pawl-Starter	2
9	93469 ②	. Washer-Pawl	2
10	214102 ②	. Spring-Pawl	2
11	100106	Key-Woodruff	1
12	110127	Screw-Hx hd 10-24 x 7/8 (SEMS)	1
13	100002	Washer-#10	2
14	83512	Stud-Special	1
15	84686A	Wire Assembly-Ground	1
16	69344	Wire Assembly-Primary	1
17	214535	Coil & Lamination Assembly	1
18	-215351	. Wire Asy-Spark plug	1
19	55061	. . Connector	1
20	95266	. . Boot	1
21	100268	. Grommet	1
22	95553 ③	Electronic Ignition Asy	1
23	95269 ③	. Wire Asy-Spark plug	1
24	102556 ③	. . Connector	1
25	95266 ③	. . Boot	1
26	110995 ③	Grommet	1
27	67057	Washer-Thrust	1
28	67056	Seal-Breaker box cover	1
29	110584	Screw-Pan hd 8-32 x 3/4	1
30	91852A	Kit-Breaker box & cover	1
31	91838	. Washer	1
32	110489	. Screw-Pan hd 6-32 x 7/16	1
33	100298	Nut-Hx 6-32	1
34	110346	Screw-Hx hd 6-32 x 3/4	1
35	110706	Screw-Pan hd 8-18 x 1/2	1
36	83126	Strap-Conduction	1
37	110811	Screw-Pan hd 8-32 x 3/8	1
38	110969	Screw-Hx hd 8-32 x 1/2	1
39	105976	Washer-#8	1
40	88808	Breaker Assembly	1
41	110338	Screw-Fil hd 8-32 x 1/2	1
42	100080	Washer-#8	1
43	85358	Condenser	1
44	67051	Seal-Breaker box	1
45	110338	Screw-Fil hd 8-32 x 1/2	2
46	110613	Washer-#8	2
47	100955	Nut-Hx 8-32	1
48	84156	Housing-Pump	1
49	-215151	Cap-Housing	1
50	62266	Plunger-Pump	1

ITEM NO.	PART NUMBER	DESCRIPTION	UNITS PER ASY.
51	105614	"O" Ring	1
52	66687	Spring-Pump	1
53	91669	Gasket-Pump	1
54	91668	Valve-Pump	1
55	110291	Screw-Pan hd 10-24 x 2-5/8	1
56	110921	Washer-Sealing	1
57	86304	Cover-Oil tank	1
58	86306	Gasket-Cover	1
59	-216052	Cap-Oil tank	1
60	86402	Valve-Check	1
61	101148	"O" Ring	1
62	91672	Hose Assembly-Oil	1
63	51506	. Screen-Hose	1
64	110865	Screw-Hx hd 10-24 x 7/8	1
65	100003	Washer-#10	1
66	215339	Pump Assembly-Pulse	1
67	91774	. Sleeve	1
68	215246	. Kit-Oil pump clip	1
69	92818	. Seal-Pulse pump	1
70	214278	. Piston Assembly-Pump	1
71	105603	. "O" Ring	1
72	86182	. Ring-Piston	1
73	60259	. Spring-Piston	1
74	62227	. Sleeve-Adjustment	1
75	110386	. Screw-Hx hd 8-32 x 1	1
76	92844	. Spring-Outlet valve	1
77	102809	. Ball	1
78	91259	. Pad-Pump	1
79	62106	Screw-Sealing	4
80	-111025	Washer-Sealing	4
81	110288	Screw-Hx hd 8-32 x 3/4	1
82	-214672	Cylinder/Crankcase Assembly	1
83	110288	. Screw-Hx hd 8-32 x 3/4	2
84	110618	. Screw-Hx hd 8-32 x 1-3/8	1
85	62065	. Bolt-Bar mounting	2
86	-89783A	. Piston Assembly	1
87	-87710	. . Pin-Piston	1
88	-92517	. . Ring Set-Piston	1
89	-110590	. . Bearing-Needle	2
90	-85352	. Connecting Rod Assembly	1
91	61627A	. . Screw-Skt hd special	2
92	63225	. . Roller-Needle (set of 20)	1
93	67906	Seal-Oil	1
94	63464	Ring-Snap	1
95	67905	Bearing-Ball	1
96	110260	Seal Oil	1
97	104357	Bearing-Needle	1
98	-87699	Crankshaft	1
99	-214223	Spark Plug (A, C, K, U)	1
99	93018	Spark Plug (B, E, F, G)	1

*Used on models with serial number prefix 11-.

① Used on models with serial number prefix 11- and 12- with 12-fin flywheel.

② Used on models with serial number prefix 12- and 24-fin flywheel.

③ Used on models with serial number prefix 12-.

McCULLOCH



● MANUFACTURING ● SALES ● SERVICE ●

McCULLOCH

P.O. Box 92180, Los Angeles, CA 90009

Copyright - McCulloch, 1982

To answer service-related questions and to solve common consumer problems quickly, we invite you to call this toll-free hot-line:

Arizona residents please call collect (602)453-3681

(800) 423-6302

Leon's Chain Saw Parts & Repair
Do Not Sell or Reproduce