

MODEL 895 Chain Saw

Model Number 600135

Serial Numbers Prefixed 13-

ILLUSTRATED PARTS LIST

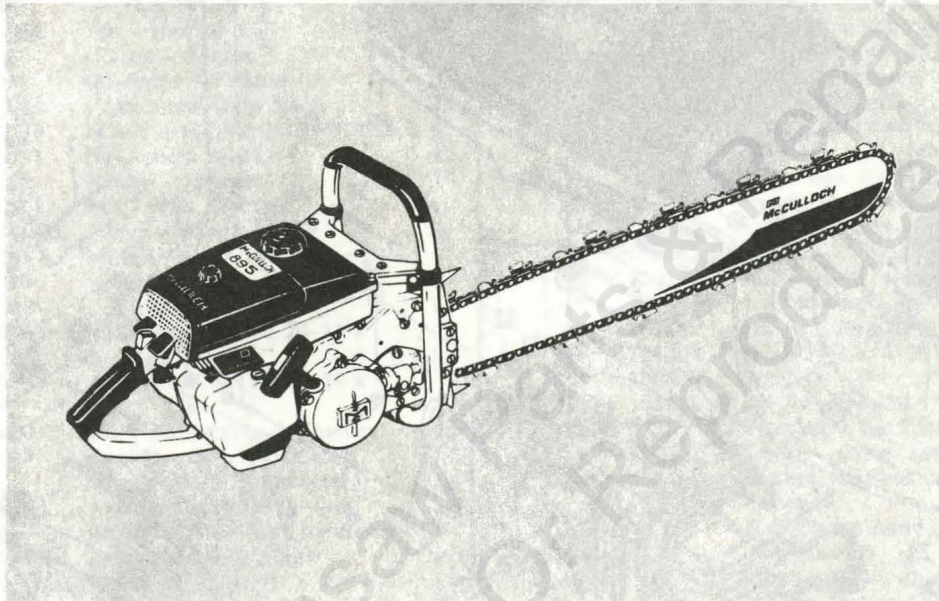

JANUARY 1972

The policy of McCulloch Corporation is one of continual improvement in design, manufacturing and engineering advancement wherever possible to assure still finer two-cycle power tools. Hence, specifications, equipment, colors, design and manufacturer's suggested list prices are subject to change without notice and McCulloch Corporation reserves the right to make such changes without prior notification or obligation to backfit or supply backfit components for units previously shipped from the factory.

	Page
Figure 1. General	2
Figure 2. Fuel System Components	4
Figure 3. Carburetor Assembly	6
Figure 4. Starter and Clutch Assemblies	8
Figure 5. Powerhead Assembly	10
Figure 6. Transmission Assembly	12
Figure 7. Lockplate Adjusting Assembly, Bar and Chain .	14
Figure 8. Handle and Control Assembly	15

 **McCULLOCH**

MODEL 895 Chain Saw

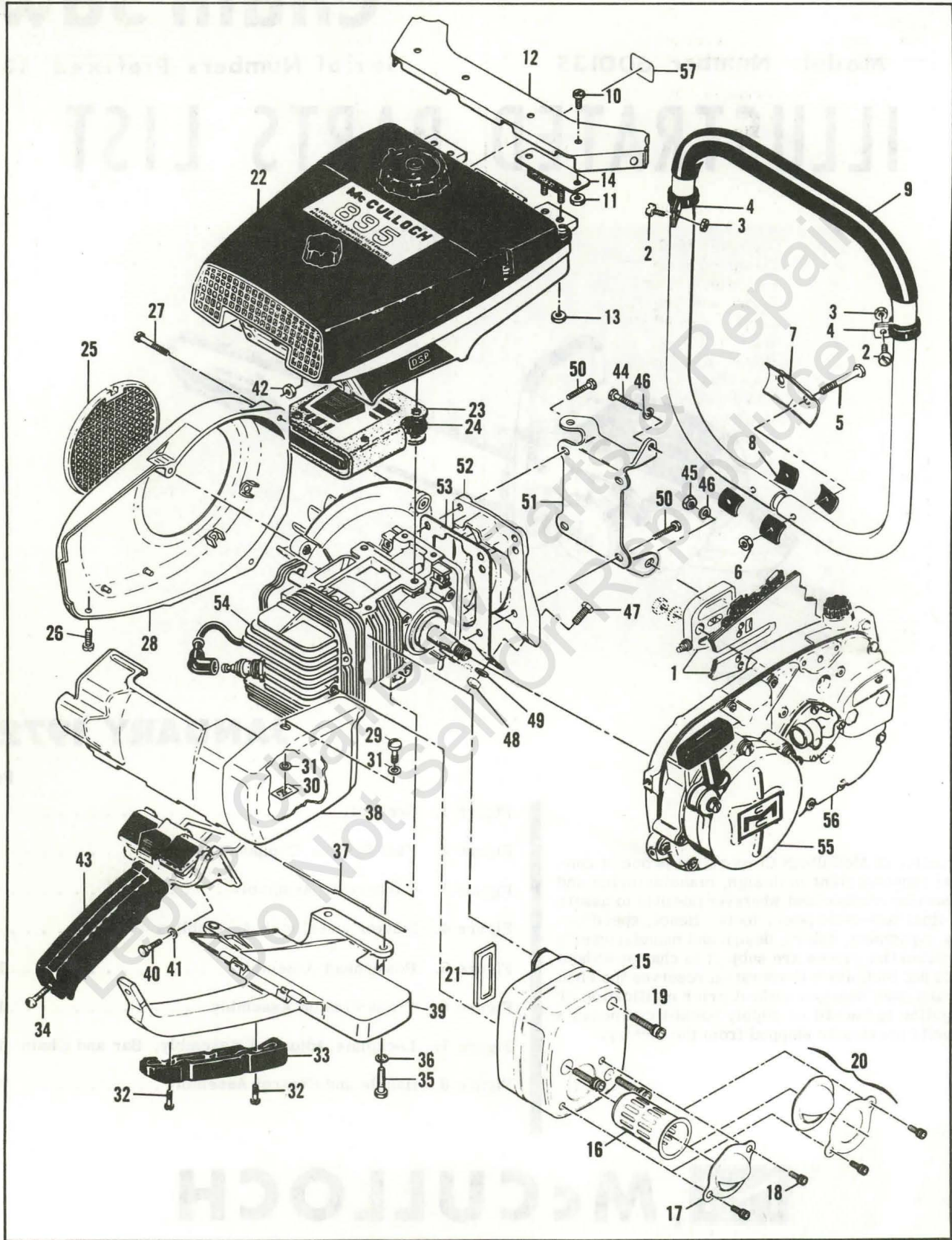

Figure 1. General

MODEL 895 Chain Saw

FIGURE 1. GENERAL

Item No.	Part Number	Description	Units Per Assy
1		Lockplate Adjusting Assy, Bar & Chain (See Figure 7)	
2	102660	Screw - Skt hd 10-24 x 7/8	2
3	105367	Nut - Hex 10-24	2
4	103923	Clamp - Frame	2
5	102125	Screw - Hex hd 1/4-20 x 1-3/4	2
6	105394	Nut - Hex 10-24	2
7	51660	Clamp - Frame	1
8	50062	Insulator - Frame	4
9	60766A	Frame and Grip Assy	1
10	104393	Screw - Pan hd 10-24 x 3/8	4
11	101191	Nut - Hex 10-24	4
12	55638	Brace - Frame	1
13	101191	Nut - Hex 10-24	4
14	55606B	Mount - Shock	2
15	84205	Muffler Assy	1
16	84690	. Baffle	1
17	*84203	. Deflector	1
18	110664	. Screw - Skt hd 10-24 x 3/8	2
19	110713	. Screw - Skt hd 10-24 x 7/8	3
20	85929	Kit - Adjustable deflector	1
21	83379	Gasket - Spark arrester	1
22		Fuel System Components (See Figure 2)	
23	67477	Gasket - Fuel tank insulator	1
24	53684A	Insulator - Fuel tank	1
25	55615	Guard - Flywheel	1
26	102500	Screw - Pan hd 10-24 x 1/2	1
27	104816	Screw - 10-24 x 1-1/4	3
28	66812	Fan Housing	1
29	51351	Screw - Special	1

Item No.	Part Number	Description	Units Per Assy
30	103741	Speednut	1
31	100005	Washer - 1/4	2
32	104483	Screw - Binder hd 10-24 x 5/8	2
33	55941	Insert - Handle	1
34	104397	Screw - Pan hd 10-24 x 7/8	1
35	102121	Screw - Hex hd 1/4-20 x 7/8	2
36	100005	Washer - 1/4	2
37	55885	Pin - Shroud hinge	1
38	66259	Shroud Assy - Cylinder & spark arrester	1
39	57872	Brace - Handle	1
40	102761	Screw - Hex hd 10-24 x 7/8	2
41	102189	Washer - #10	2
42	102067	Nut - Hex 10-24	2
43		Handle & Control Assy (See Figure 9)	
44	100882	Screw - Hex hd 1/4-20 x 3/4	1
45	100248	Nut - Hex 1/4-28	1
46	100153	Lockwasher - 1/4	2
47	100882	Screw - Hex hd 1/4-20 x 3/4	1
48	105394	Nut - Hex 1/4-20	1
49	100005	Washer - 1/4	1
50	101982	Screw - Hex hd 1/4-20 x 1	4
51	61225	Bracket - Gearcase	1
52	65743	Cover - Crankcase bottom	1
53	65654	Gasket - Crankcase bottom cover	1
54		Powerhead Assy (See Figure 5)	
55		Starter & Clutch Assy (See Figure 4)	
56		Transmission Assy (See Figure 6)	
57	59445	Decal - Oiler	1

*Not used on this model.

MODEL 895 Chain Saw

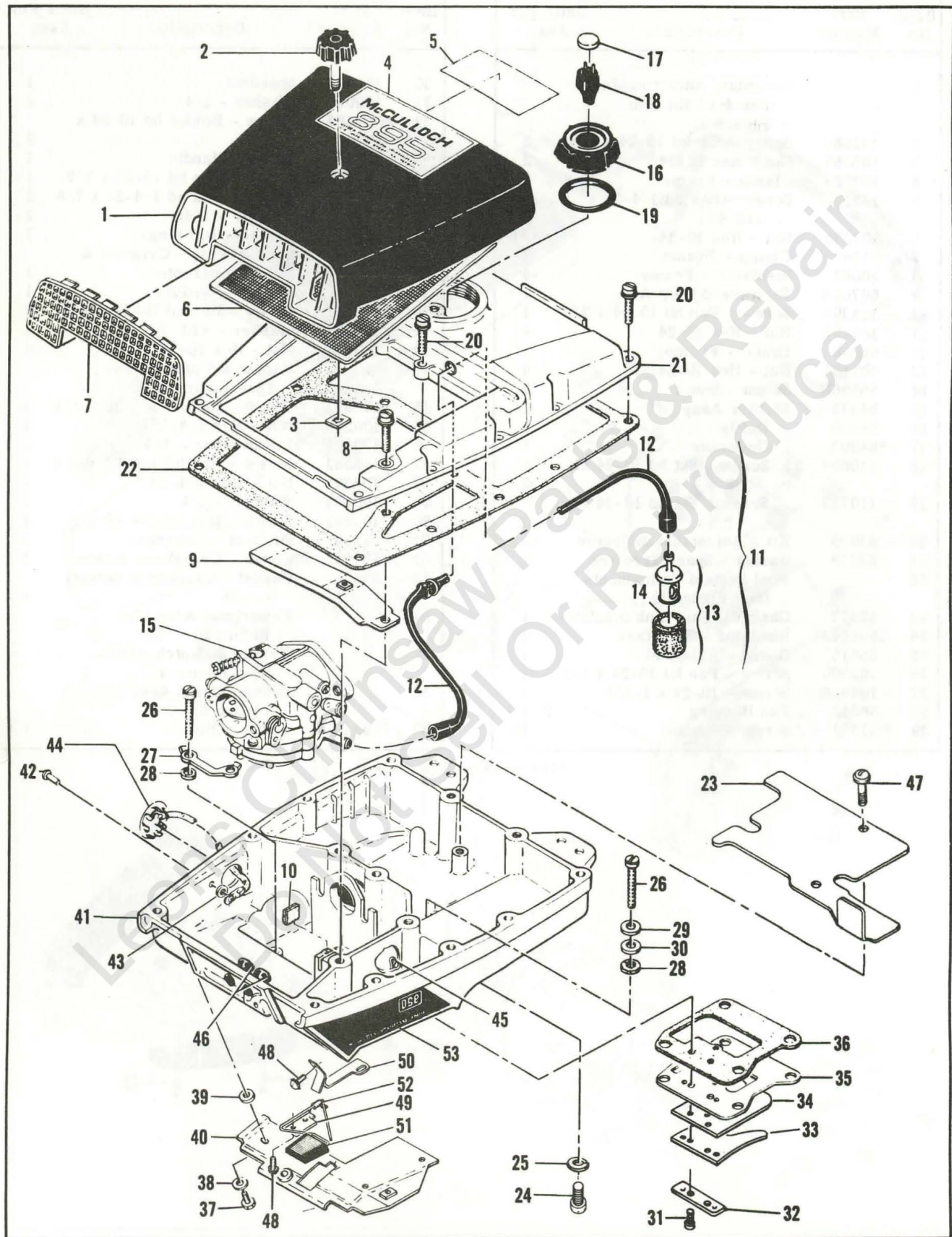

Figure 2. Fuel System Components

MODEL 895 Chain Saw

FIGURE 2. FUEL SYSTEM COMPONENTS

Item No.	Part Number	Description	Units Per Assy
1	60427A	Cover Assy - Air cleaner	1
2	60243	. Knob - Air cleaner cover	1
3	83367	. Speednut	1
4	86289	Nameplate	1
5	83559	Instruction Plate	1
6	55498	Screen - Air cleaner	1
7	55659	Grill - Air cleaner cover	1
8	104396	Screw - Pan hd 10-24 x 3/4	1
9	55634	Anchor Assy - Air cleaner	1
10	51394	Felt	1
11	63831	Hose Assy - Fuel line	1
12	63669	. Hose - Fuel	1
13	53679B	. Pickup Assy - Fuel	1
14	61159	. . Filter - Fuel	1
15		Carburetor Assy (See Figure 3)	
16	55934B	Cap Assy - Fuel	1
17	55063	. Filter - Fuel cap	1
18	53766A	. Valve - Check	1
19	101348	"O" Ring - Fuel cap	1
20	104396	Screw - Pan hd 10-24 x 3/4	14
21	69001	Cover - Fuel tank	1
22	65632	Gasket - Fuel tank	1
23	63650	Liner - Fuel tank	1
24	100633	Screw - Skt hd 1/4-20 x 1/2	1
25	105043	Lockwasher	1
26	55948A	Screw - Fuel tank	4
27	68654	Lockplate	1
28	68203	Washer - Insulating	4

Item No.	Part Number	Description	Units Per Assy
29	102189	Washer - #10	2
30	103744	Washer - Sealing	2
31	103740	Screw - Hex hd 8-32 x 7/8	2
32	51480	Lockplate	1
33	86294	Guard - Valve	1
34	86293	Valve - Reed	1
35	86284	Plate - Reed	1
36	86292	Gasket	1
37	102388	Screw - Hex hd 10-24 x 5/8	3
38	102189	Washer	3
39	68203	Washer - Insulating	2
40	63652	Shield Assy - Fuel tank	1
41	86296	Bottom Assy - Fuel tank	1
42	104504	. Rivet	1
43	101871	. Washer - Plain	1
44	51396A	. Cover Assy - Adjustment hole	1
45	104310	. Pin - Cotter	1
46	68258	. Grommet	2
47	110054	. Screw - Pan hd 6-32 x 3/8 (SEMS)	2
48	105249	. Screw - 8-32 x 3/8 (SEMS)	3
49	63619	Plate - Lever retaining	1
50	64582	Retainer - Lever	1
51	63914A	Lever Assy - Compression release	1
52	63827	Spring - Lever	1
53	66269	Emblem - Fuel tank	1

SERVICE SPECIFICATIONS

Spark Plug Gap -----	0.025 in.
Lamination Gap -----	0.010 to 0.015 in.
Breaker Point Gap -----	0.018 in.
Carburetor Adjustment	
Idle Needle - Preliminary adjustment	1 turn open.
Adjust for smooth idle and acceleration.	
Main Needle - Preliminary adjustment	1 turn open.
Adjust for maximum power under load.	
Torque Values	
Flywheel Nut -----	350 to 400 inch-pounds.
Clutch Nut -----	240 to 300 inch-pounds.
Connecting Rod Screws -----	105 to 110 inch-pounds.

MODEL 895 Chain Saw

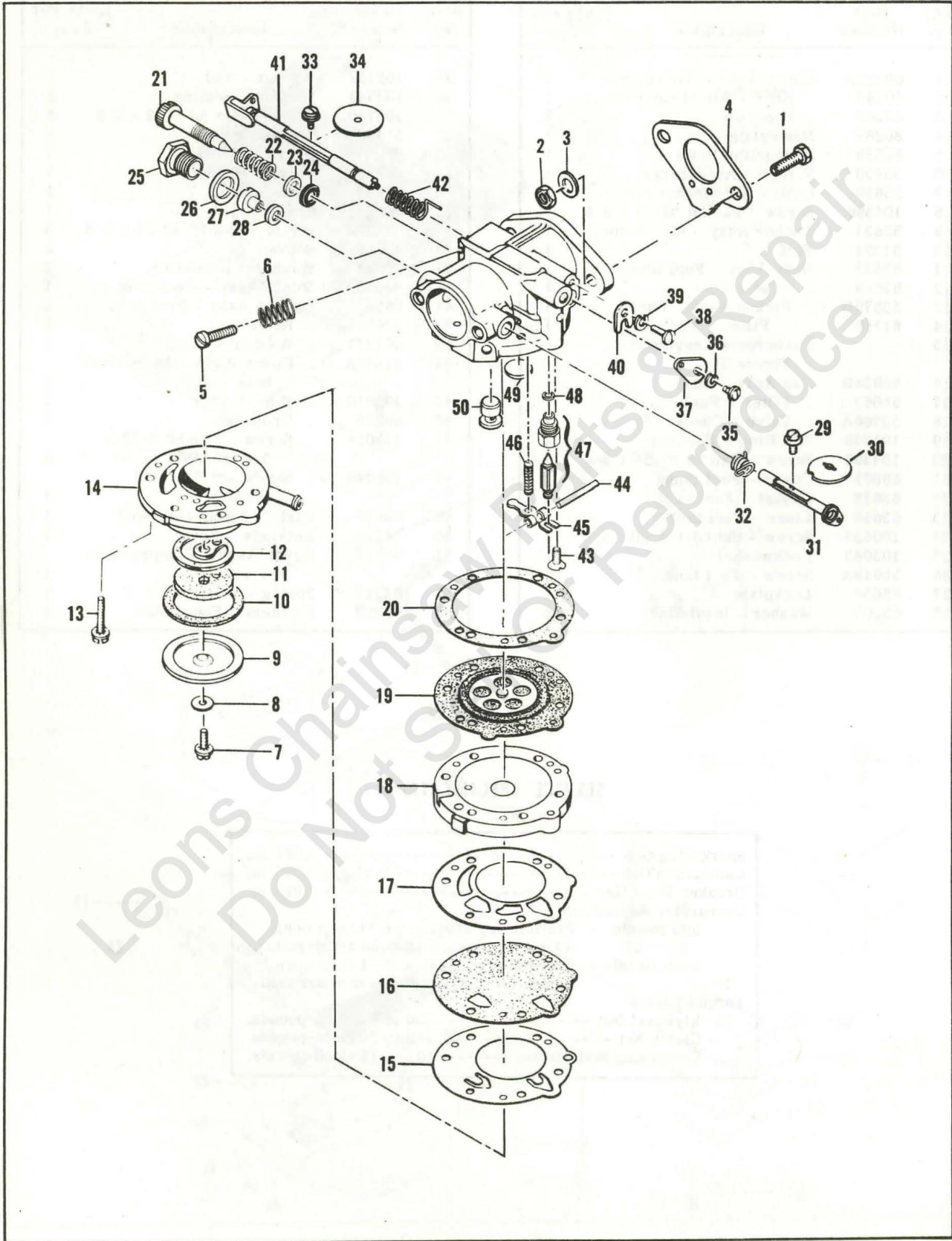

Figure 3. Carburetor Assembly

MODEL 895 Chain Saw

FIGURE 3. CARBURETOR ASSEMBLY

Item No.	Part Number	Description	Units Per Assy
1	100882	Screw - Hex hd 1/4-20 x 3/4	2
2	103242	Nut - Hex 1/4-20	2
3	100005	Washer - 1/4	2
4	86286	Gasket - Carburetor	1
	86285	Carburetor Assy	1
5	52940	. Screw - Idle speed regulating	1
6	51705	. Spring - Idle speed screw	1
7	50797	. Screw - Fuel strainer cover	1
8	50798	. Gasket - Cover screw	1
9	50796	. Cover - Fuel strainer	1
10	51704	. Gasket - Cover	1
11	53717	. Filter - Fuel	1
12	53565	. Gasket - Filter	1
13	87230	. Screw Assy - Fil hd 6-32 x 3/4	6
14	87224	. Body - Fuel pump	1
15	84030	. Diaphragm - Check valve	1
16	84029	. Diaphragm - Fuel pump	1
17	65592	. Gasket - Fuel pump	1
18	87225	. Cover - Diaphragm	1
19	66167	. Diaphragm - Metering	1
20	65591	. Gasket - Diaphragm	1
21	87223	. Needle - Idle fuel mixture	1
22	52936	. Spring - Needle	1
23	52937	. Washer - Needle	1
24	52938	. Packing - Needle	1
25	84037	. Plug - Main fuel jet	1
26	52941	. Gasket - Plug	1

Item No.	Part Number	Description	Units Per Assy
27	84058	. Jet - Main fuel (0.039 orifice)	1
	84059	. Jet - Main fuel (0.037 orifice)	Alt.
	84035	. Jet - Main fuel (0.041 orifice)	Alt.
	84057	. Jet - Main fuel (0.043 orifice)	Alt.
28	84036	. Gasket - Jet	1
29	51721	. Screw - Choke shutter (SEMS)	1
30	84026	. Shutter - Choke	1
31	87227	. Shaft Assy - Choke	1
32	87226	. Spring - Choke return	1
33	51721	. Screw - Throttle shutter	1
34	84041	. Shutter - Throttle	1
35	51719	. Screw - Throttle lever	1
36	100261	. Lockwasher - #4	1
37	87231	. Lever - Throttle shaft	1
38	51717	. Screw - Throttle shaft clip	1
39	100252	. Lockwasher - #8	1
40	51716	. Clip - Throttle shaft	1
41	87228	. Shaft Assy - Throttle	1
42	87232	. Spring - Throttle return	1
43	66644	. Screw - Lever pin	1
44	84033	. Pin - Lever	1
45	84032	. Lever - Inlet valve	1
46	66404	. Spring - Lever	1
47	84034	. Needle & Seat - Inlet	1
48	51708	. Gasket - Inlet	1
49	51583	. Plug - Welch 3/8 in.	1
50	87229	. Valve Assy - Check	1

ACCESSORIES

Part Number	Description
61040	Wrench & Screwdriver Combination
84381	Owner's Manual
64797	Wrench - Spark plug
86419	Guide - Timing
101522	Wrench - Muffler
63432	Spark Plug - AC CS 42T
65551	Spark Plug - AC CS 41T
62884	Piston Assy - 2.248 in. dia.
62423	. Ring Set - 2.248 in. dia.
60464	Transmission Assy - 3:1 Conversion Complete
60463	Transmission Assy - 3.6:1 Conversion Complete

Part Number	Description
60348B	Kit - Clutch & Drum Assy (3.6:1 Transmission)
60349B	Kit - Clutch & Drum Assy (2:1 & 3:1 Transmission)
60462	Gear Set - Idler & sprocket (2:1 Transmission)
62115	Gear Set - 3:1 Transmission Conversion
62114	Gear Set - 3.6:1 Transmission Conversion
60914D	Pump & Gasket Assy - Oiler (3:1 Transmission)
60915D	Pump & Gasket Assy - Oiler (3.6:1 Transmission)

MODEL 895 Chain Saw

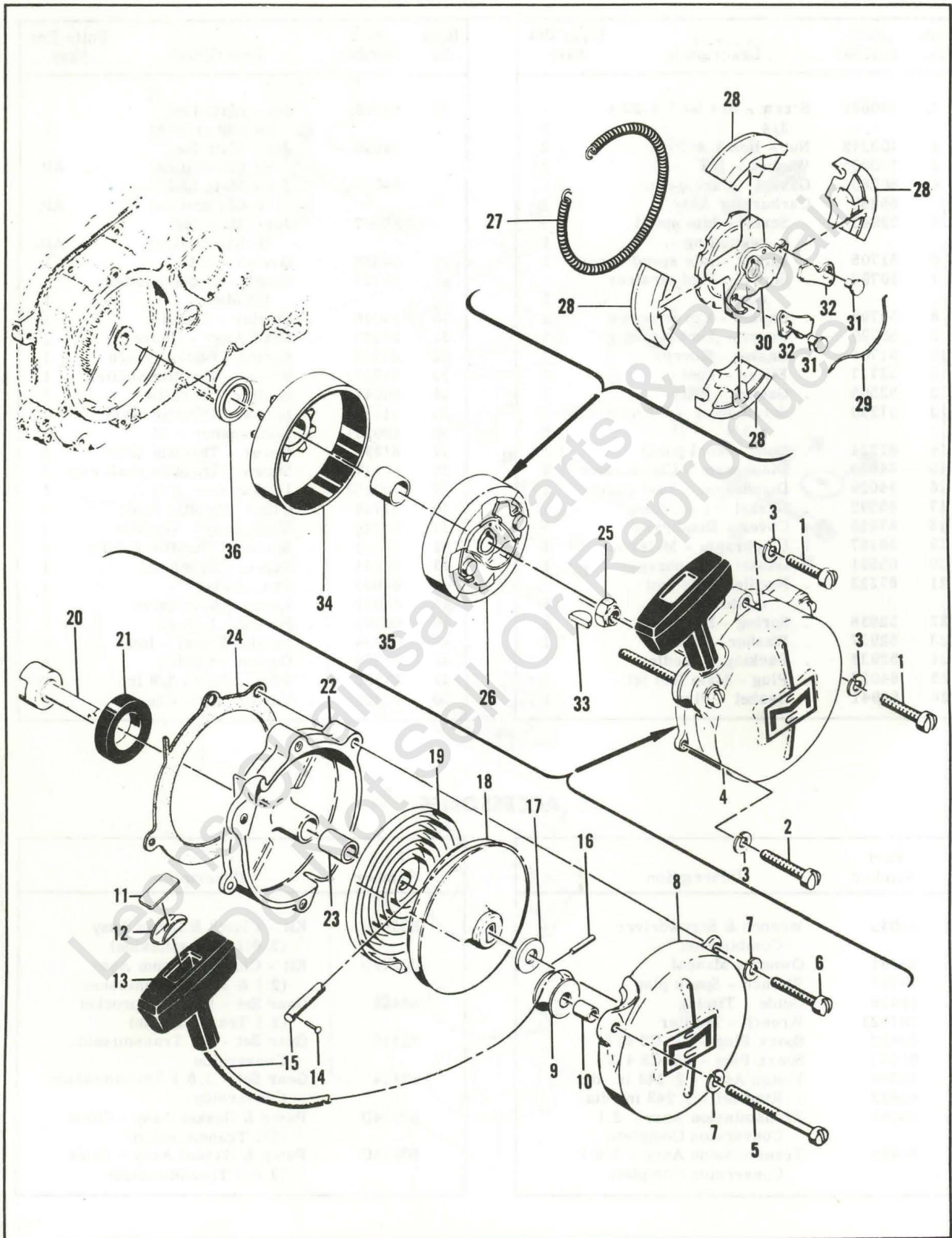

Figure 4. Starter and Clutch Assemblies

MODEL 895 Chain Saw

FIGURE 4. STARTER AND CLUTCH ASSEMBLIES

Item No.	Part Number	Description	Units Per Assy
1	102212	Screw - Fil hd 10-24 x 1-3/4	2
2	102135	Screw - Fil hd 10-24 x 2	1
3	101194	Lockwasher #10	3
4	53303	Starter Assy	1
5	103840	. Screw - Fil hd 10-24 x 3-1/2	1
6	102135	. Screw - Fil hd 10-24 x 2	2
7	101194	. Lockwasher #10	3
8	55024B	. Cover - Starter	1
9	51138	. Pulley - Starter rope	1
10	103536	. Bearing - Starter pulley	1
11	57232	. Plate - Starter handle	1
12	57231	. Cup - Starter handle	1
13	57230	. Handle - Starter	1
14	101136	. Rivet	1
15	28716	. Rope - Starter	1
16	103047	. Pin - Roll	1
17	104457	. Washer - 3/8	1
18	55871	. Drum - Starter	1

Item No.	Part Number	Description	Units Per Assy
19	51665	. Spring - Rewind	1
20	55110A	. Shaft - Starter	1
21	104439	. Seal - Oil	1
22	65364	. Base Assy - Starter	1
23	55591	. . Bearing - Starter base	1
24	55983	Gasket - Starter base	1
25	103746	Nut - Flexloc 3/8-24	1
26	61227	Clutch Assy	1
27	86079	. Spring - Shoe retaining	1
28	61228	. Shoe - Clutch	4
29	28766A	. Spring - Starter pawl	1
30	61322	. Rotor & Pawl Assy - Clutch	1
31	28917	. . Pin - Starter pawl	1
32	28765	. . Pawl - Starter	1
33	103879	Key - Woodruff	1
34	61321	Drum & Liner Assy - Clutch	1
35	51700	. Bushing - Clutch drum	1
36	68182	Spacer - Clutch drum	1

Leons Chainsaw Parts & Repair
Do Not Sell Or Repair

MODEL 895 Chain Saw

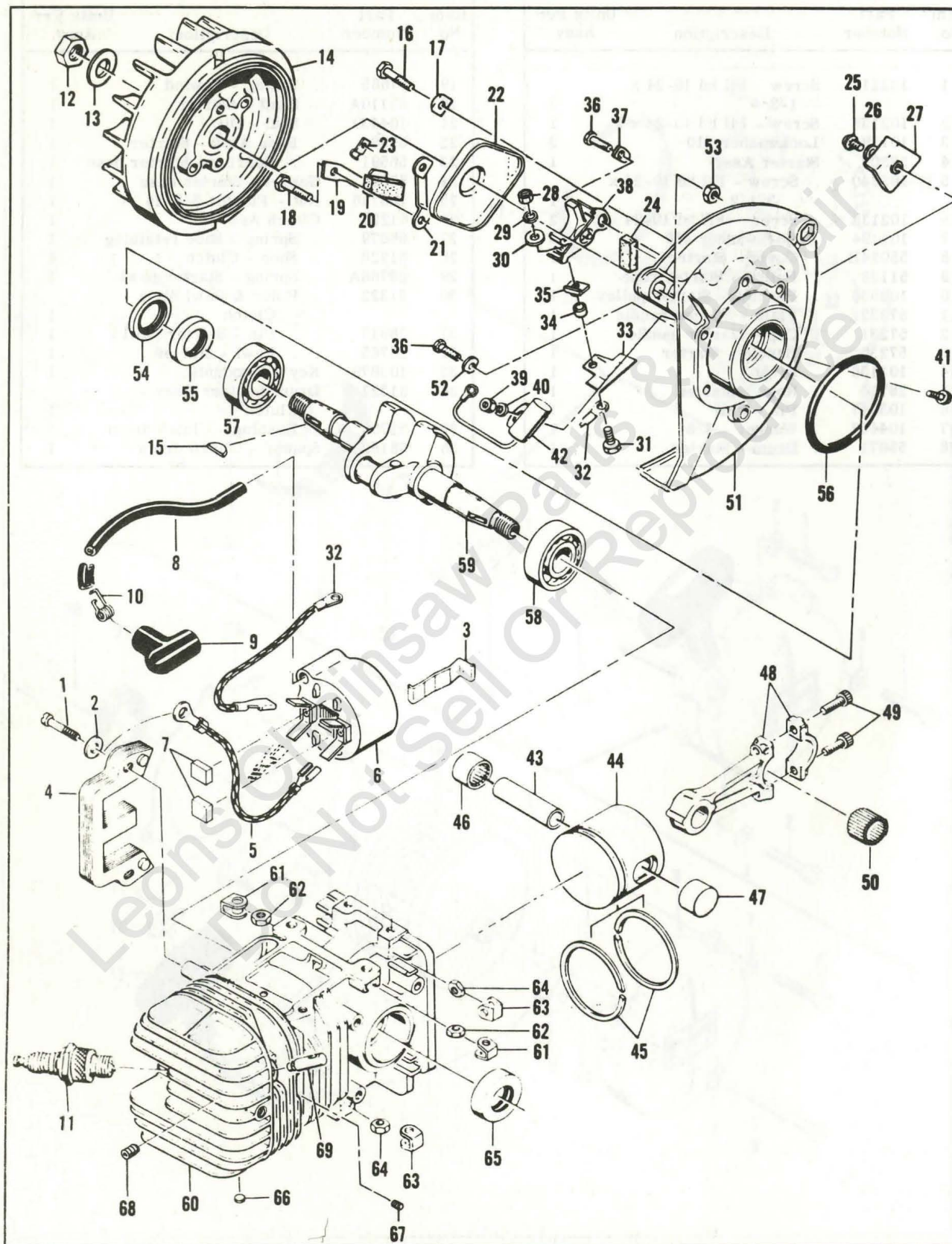

Figure 5. Powerhead Assembly

MODEL 895 Chain Saw

FIGURE 5. POWERHEAD ASSEMBLY

Item No.	Part Number	Description	Units Per Assy
1	104815	Screw - Hex hd 10-24 x 7/8	2
2	100352	Washer - #10	2
3	51253	Retainer - Coil	1
4	51251	Lamination Assy - Coil	1
5	63639	Wire Assy - Ground	1
6	84972	Coil and Terminal Assy	1
7	67863	. Spacer - Lamination	2
8	69966	. Wire Assy - Spark plug	1
9	62926	. . Boot - Spark plug	1
10	62932	. . Connector - Spark plug wire	1
11	63097	Plug - Spark 14 mm	1
12	40655	Nut - Hex 7/16	1
13	101270	Washer - Special	1
14	68281	Flywheel Assy	1
15	103879	Key - Woodruff	1
16	102763	Screw - Hex hd 10-24 x 3/4	2
17	36388	Lockplate	1
18	102763	Screw - Hex hd 10-24 x 3/4	4
19	57815	Strap - Seal	1
20	50664	Seal - Breaker box drain	1
21	55977	Clip - Breaker box cover	2
22	55766B	Cover - Breaker box	1
23	104230	Speednut	1
24	54184	Wiper - Felt	1
25	110055	Screw - 8-32 x 3/8 (SEMS)	1
26	100080	Washer - #8	1
27	57829	Clamp - Ignition wire	1
28	104551	Nut - Hex 8-32	1
29	104553	Lockwasher	1
30	100080	Washer - #8	1
31	110338	Screw - Hex hd 8-32 x 1/2	1
32	63628	Wire Assy - Primary	1
33	55782A	Insulator - Primary wire assy	1
34	57769	Insulator - Ignition screw	1
35	57770A	Insulator - Breaker spring	1
36	104733	Screw - 8-32 x 1/2 (SEMS)	2

Item No.	Part Number	Description	Units Per Assy
37	57767A	Lockplate	1
38	57765B	Breaker Assy	1
39	100251	Nut - Hex 8-32	1
40	100057	Lockwasher - #8	1
41	103748	Screw - 8-32 x 1/2	1
42	85358	Condenser	1
43	69408	Pin - Piston	1
44	62883	Piston Assy - 2.217 in. dia. (Also see Oversize Assy)	1
45	62422	. Ring Set - Piston 2.217	1
46	104519	. Bearing - Needle	1
47	62868	. Bearing - Needle (closed end)	1
48	47903	Connecting Rod Assy	1
49	60210A	. Screw - Skt hd 10-32 x 5/8	2
50	85420	. Roller - Needle	24
51	84193	Crankcase Cover Assy	1
52	55778E	. Washer - Breaker retainer	1
53	101326	. Nut - Hex 10-24	3
54	57897	. Seal - Oil	1
55	57898	. Seal - Oil	1
56	104523	"O" Ring	1
57	100824	Bearing - Ball	1
58	104490	Bearing - Ball	1
59	58128	Crankshaft	1
60	67421	Cylinder Assy - Crankcase	1
61	28053	. Retainer - Nut	2
62	101326	. Nut - Hex 10-24	2
63	18556A	. Retainer - Nut	6
64	105394	. Nut - Hex 1/4-20	6
65	57732	. Seal - Oil	1
66	110685	. Plug - Cup	3
67	83374	. Insert - Taplok	3
68	103614	. Screw - Skt hd 1/4-20 x 3/8	1
69	86295	. Valve - Compression release	1

MODEL 895 Chain Saw

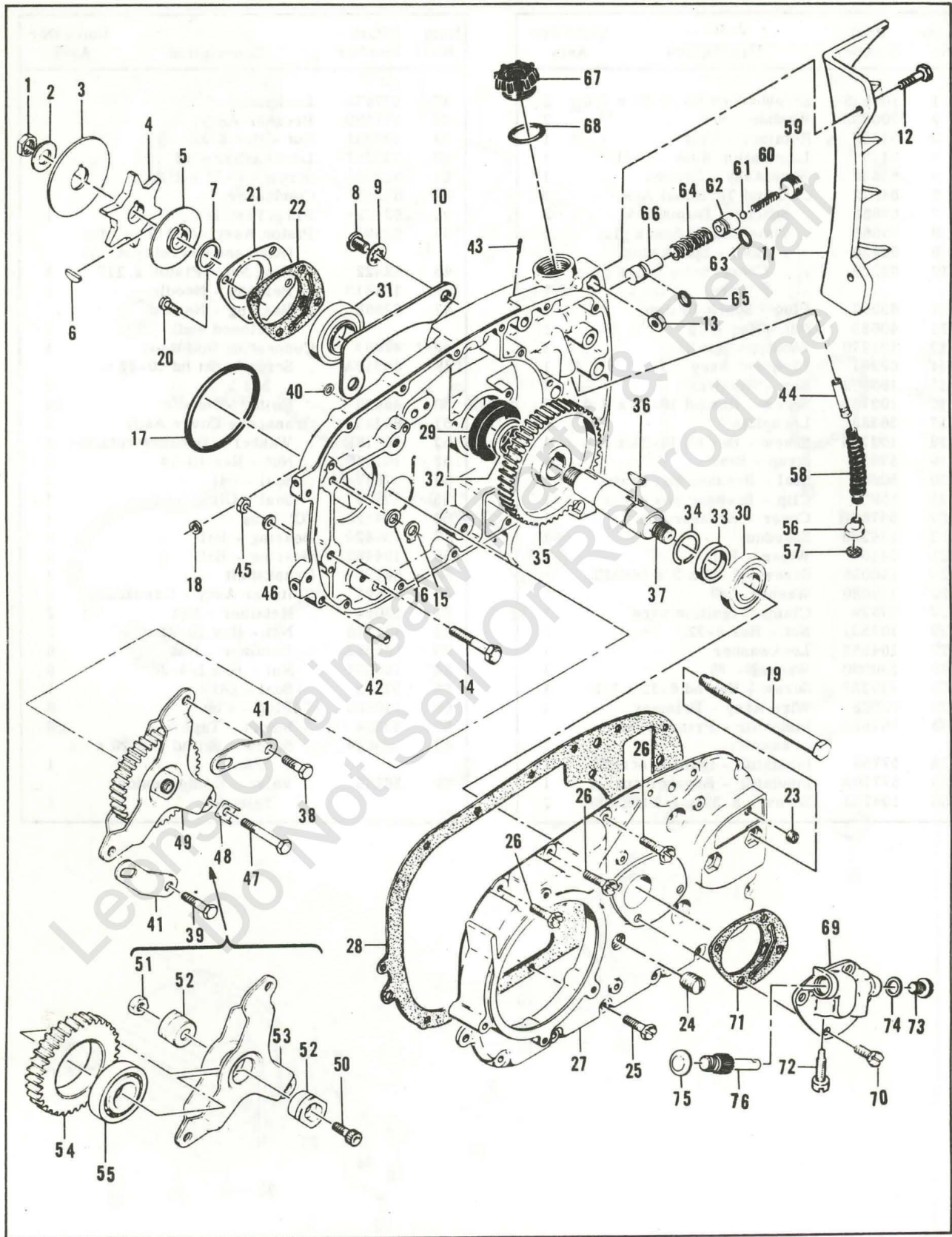

Figure 6. Transmission Assembly

MODEL 895 Chain Saw

FIGURE 6. TRANSMISSION ASSEMBLY.

Item No.	Part Number	Description	Units Per Assy
1	60972	Nut - Special	1
2	100593	Washer - 7/16	1
3	51627	Plate - Chain guide	1
4	36791A	Sprocket - 7 tooth, 9/16 in. pitch	1
	36790A	Sprocket - 6 tooth, 9/16 in. pitch	Alt.
	36644A	Sprocket - 7 tooth, 1/2 in. pitch	Alt.
	36020B	Sprocket - 6 tooth, 1/2 in. pitch	Alt.
	52069A	Sprocket - 7 tooth, 0.404 in. pitch	Alt.
5	36019A	Shroud - Sprocket	1
6	100256	Key - Woodruff	1
7	55737	Spacer - Sprocket	1
8	102415	Screw - Pan hd 10-24 x 3/8 s/t	2
9	101194	Lockwasher - #10	2
10	61224	Cover - Pushrod	1
11	61783	Kit - Spike	1
12	100882	Screw - Hex hd 1/4-20 x 3/4	2
13	105394	Nut - Hex 1/4-20	2
14	102128	Screw - Hex hd 1/4-20 x 1-1/4	3
15	36306	Lockplate	1
16	100004	Washer - 1/4	1
17	104535	"O" Ring	1
18	57736	Washer - Oiler rod felt	1
	60633	Transmission Assy (2:1)	1
19	51631A	Bolt - Bar mounting	2
20	104835	Screw - Pan hd 10-24 x 1/2 (SEMS)	4
21	60408	Retainer - Bearing	1
22	60409	Gasket - Retainer	1
23	104869	Plug - Pipe 1/16-27	1
24	104218	Plug - Pipe 3/8-18	1
25	103464	Screw - Hex hd 10-24 x 3/4 (SEMS)	11
26	103947	Screw - Hex hd 10-24 x 1 (SEMS)	3
27	58779	Cover - Gearcase	1
28	68639	Gasket - Gearcase cover	1
29	104298	Seal - Oil	1
30	101039	Bearing - Ball	1
31	104422	Bearing - Ball	1
32	55715	Spacer - Gear	1
33	60407	Spacer - Gear	1
	60420	Shaft & Sprocket Gear Assy	1
34	104451	Ring - Retaining	1

Item No.	Part Number	Description	Units Per Assy
35	57999	Gear - Sprocket drive	1
36	55953	Key - Sprocket gear	1
37	60470A	Shaft - Sprocket	1
	60461	Gearcase Assy	1
38	103280	Screw - Hex hd 1/4-28 x 5/8	1
39	103413	Screw - Hex hd 1/4-28 x 1	1
40	30351884	Washer - 1/4	2
41	60186	Strap - Idler yoke	2
42	100993	Pin - Dowel	1
43	100010	Pin - Cotter	1
44	60389	Valve Assy - Check	1
45	100640	Nut - Hex 1/4-28	2
46	100004	Washer - 1/4	1
47	104351	Screw - Hex hd 1/4-28 x 1-13/32	1
48	55539	Lockplate - Yoke	1
49	55722	Gear and Yoke Assy	1
50	100201	Screw - Skt hd 1/4-28 x 1/2	1
51	100640	Locknut - Hex 1/4-28	1
52	57493	Hub - Bearing	2
53	53820	Yoke Assy	1
54	55728	Gear - Idler	1
55	100824	Bearing - Ball	1
56	51505	Weight Assy	1
57	51506	Screen - Pickup	1
58	28007	Hose - Pickup	1
59	51755	Plug - Oiler valve	1
60	51944	Spring	1
61	100549	Ball - Steel	1
	60622A	Body Assy - Oiler	1
62	57721B	Body - Oiler	1
63	101056	"O" Ring	1
64	19236	Spring - Oiler	1
	51472	Piston Assy - Oiler	1
65	101056	"O" Ring	1
66	36126	Piston - Oiler	1
67	57129A	Cap - Filler	1
68	101148	"O" Ring	1
69	60466D	Pump & Gasket Assy - Oiler (2:1)	1
70	110172	Screw - Fil hd 10-24 x 3/4 (SEMS)	4
71	60409	Gasket - Oiler pump	1
72	61398	Screw - Special	1
73	60959	Plug - Special	1
74	60964	Shim - 0.015 in.	AR
75	104791	Plug - Expansion 5/8 in.	1
76	61810	Plunger - Oiler pump (2:1)	1

MODEL 895 Chain Saw

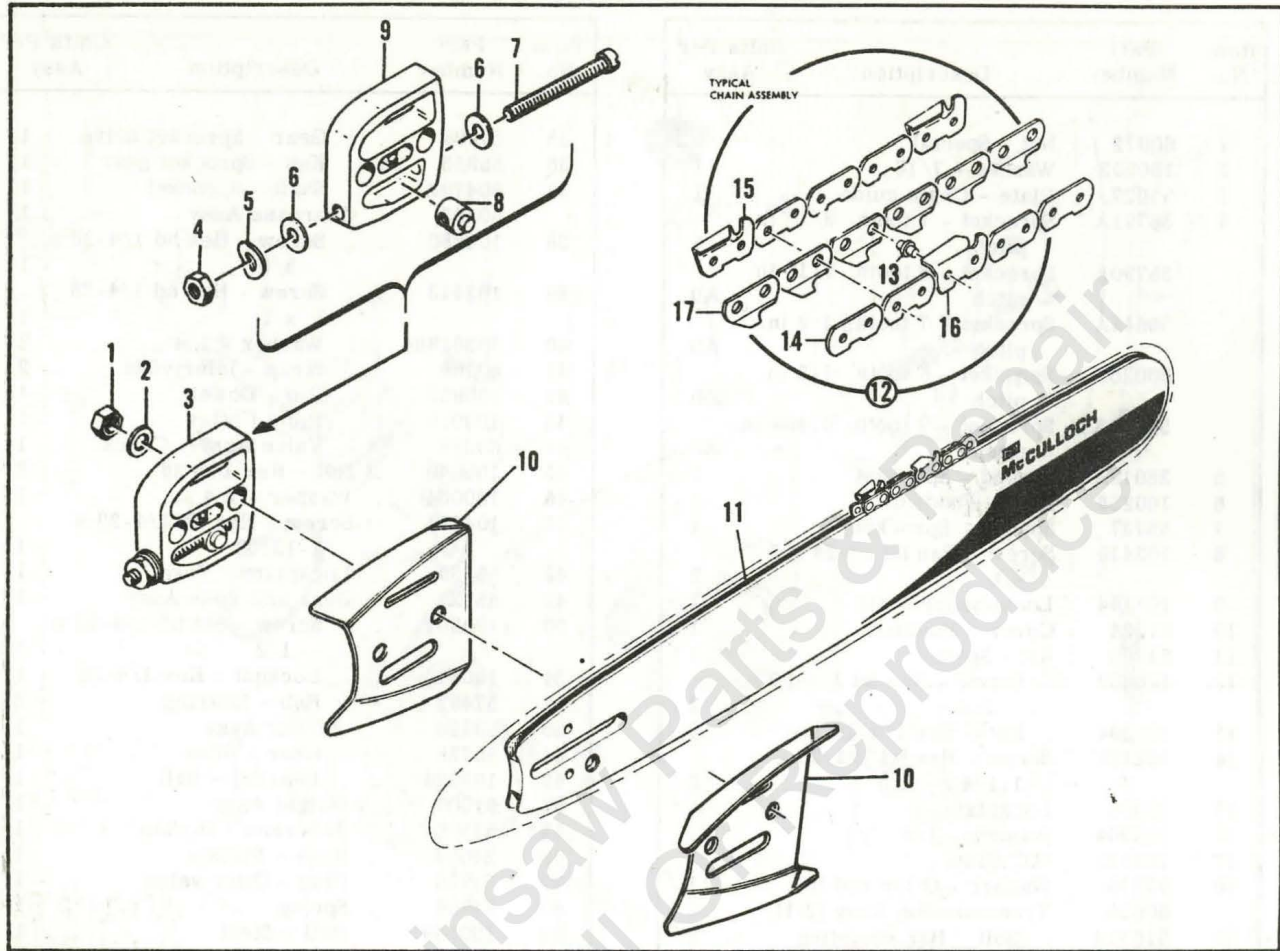

FIGURE 7. LOCKPLATE ADJUSTING ASSEMBLY

Item No.	Part Number	Description	Units Per Assy
1	110625	Nut - Hex 3/8-24	2
2	100393	Washer - 3/8 in.	2
3	52211D	Lockplate Adjusting Assy	1
4	100640	. Nut - Hex 1/4-28	1
5	102813	. Washer - Spring	1
6	102843	. Washer - Plain 1/4 in.	2
7	103919	. Screw - Fil hd 1/4-28 x 2-1/2	1
8	52207C	. Nut - Adjusting	1

Item No.	Part Number	Description	Units Per Assy
9	52206B	. Lockplate	1
10	64935	Bar Plate	2
11		Typical McCulloch Bar	1
12		Typical Chain Assy	1
13		. Rivet	
14		. Side Link	
15		. Cutter - L. H.	
16		. Cutter - R. H.	
17		. Center Link	

MODEL 895 Chain Saw

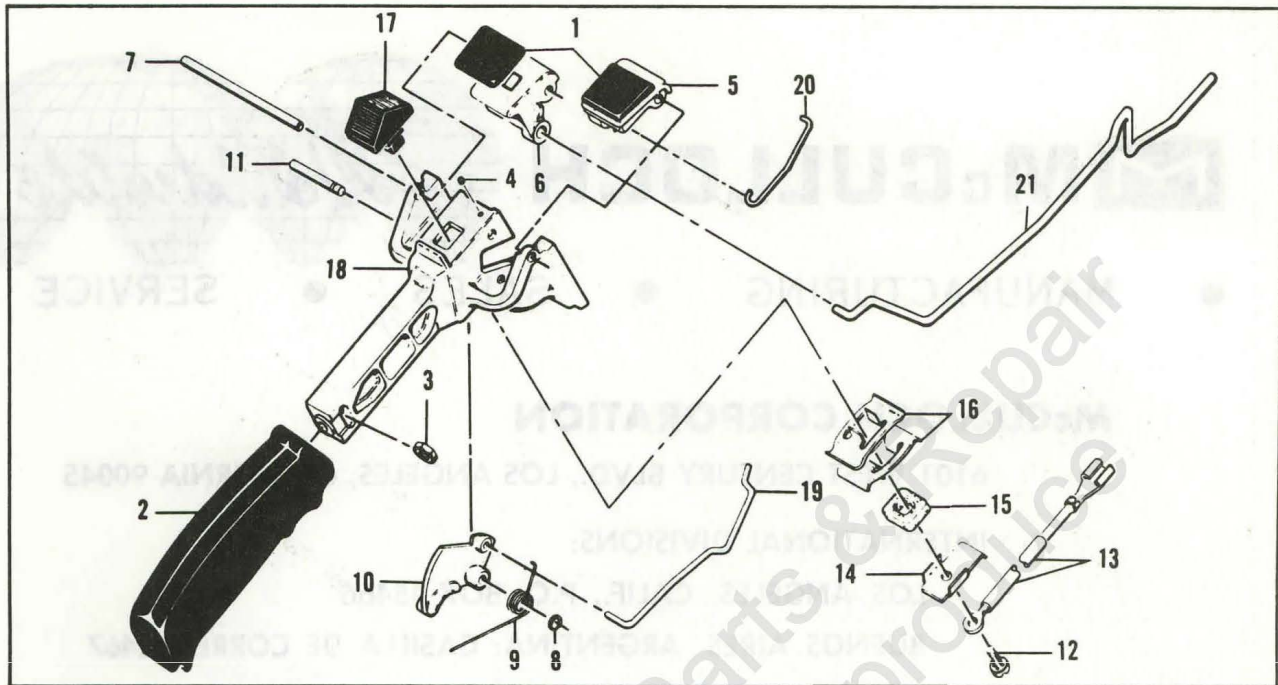

FIGURE 8. HANDLE AND CONTROL ASSEMBLY

Item No.	Part Number	Description	Units Per Assy
1	55670	Grommet	2
	64860	Handle & Control Assy	1
2	55624A	. Grip - Handle	1
3	101326	. Nut - Hex 10-24	1
4	104484	. Screw - Set 8-32 x 1/4	1
5	55968A	. Button - Primer control	1
6	55969A	. Button - Oiler control	1
7	51344A	. Shaft - Primer & oiler buttons	1
8	104501	. Retainer - Trigger pin	1
9	55674	. Spring - Trigger return	1
10	63663	. Trigger	1

Item No.	Part Number	Description	Units Per Assy
11	50507	. Pin - Trigger	1
12	110706	. Screw - Pan hd 8-18 x 1/2 (SEMS)	1
13	63662	. Wire Assy - Stop switch	1
14	51279	. Contact - Switch	1
15	51555	. Insulator - Switch	1
16	51554A	. Detent - Switch	2
17	57718	. Button - Switch	1
18	55986	. Handle	1
19	55873	Pushrod - Throttle	1
20	84319	Pushrod - Choke	1
21	57719	Pushrod - Oiler	1



McCULLOCH



● MANUFACTURING ● SALES ● SERVICE ●

McCULLOCH CORPORATION

6101 WEST CENTURY BLVD., LOS ANGELES, CALIFORNIA 90045

INTERNATIONAL DIVISIONS:

LOS ANGELES, CALIF., P.O. BOX 45466

BUENOS AIRES, ARGENTINA: CASILLA DE CORREO 2467

SINGAPORE, 431-432 PEOPLE'S PARK COMPLEX

McCULLOCH OF CANADA LTD.

6338 VISCOUNT ROAD, MALTON, ONTARIO, CANADA

McCULLOCH OF EUROPE, N. V.

ANTOON SPINOYSTRAAT, 5, B-2800 MECHELEN, BELGIUM

McCULLOCH OF AUSTRALIA PTY., LTD.

P.O. BOX 223, SEVEN HILLS, N.S.W. 2147, AUSTRALIA