

Chain Saw

MODEL 450

SERIAL NO. 14001 & UP

ILLUSTRATED PARTS LIST

SEPTEMBER 1965

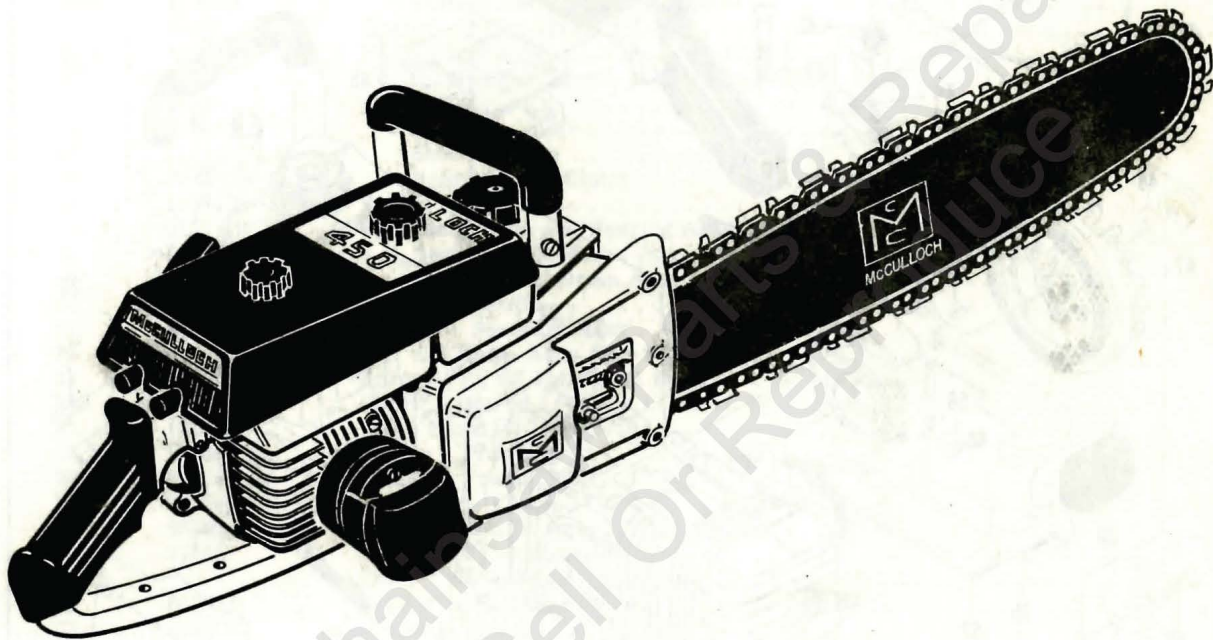

The following pages contain an illustrated parts list for the Model 450 Chain Saw. Due to small differences between saws, it is important that the Serial Number of your saw be included whenever spare parts are ordered.

	Page
Figure 1. Engine Exploded View - General	2
Figure 2. Starter and Crankcase Cover Assemblies	4
Figure 3. Oiler Tank and Fuel Tank Assemblies	6
Figure 4. Cover and Airbox Assemblies	8
Figure 5. McCulloch Carburetor Assembly	12
Figure 6. Powerhead Assembly	10
Figure 7. Clutch Guard - Bar and Chain Assembly	14

MCCULLOCH CORPORATION

6101 West Century Boulevard, Los Angeles, California 90045

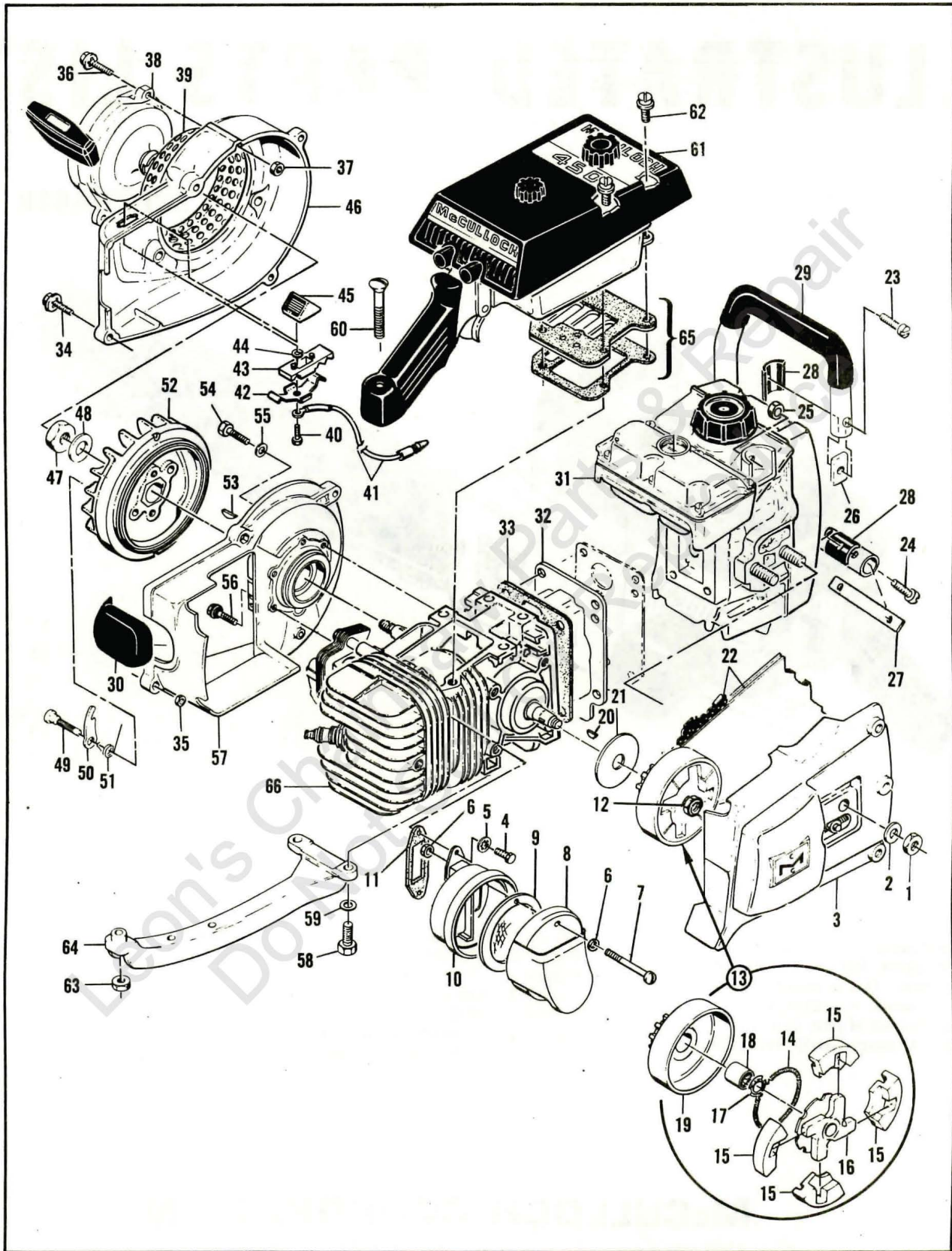

Figure 1. Engine Exploded View - General

FIGURE 1. ENGINE EXPLODED VIEW—GENERAL.

SERIAL NO. 14001 & UP

Index No.	Part Number	Nomenclature	Units Per Assy
1	103729	Nut - Hex 3/8-24	2
2	100006	Washer - Plain 3/8 in.	2
3		Guard Assy - Clutch (See Figure 7)	1
4	102388	Screw - Hex hd 10-24 x 5/8 in. lg.	2
5	103100	Lockwasher - No. 10 internal	2
	53204C	Spark Arrester Assy	1
6	101191	. Nut - Hex 10-24	2
7	110371	. Screw - Fil hd 10-24 x 1-5/8 in. lg.	2
8	53205B	. Top Assy - Spark arrester	1
9	*51968	. Baffle	1
10	52424A	. Bottom Assy - Spark arrester	1
11	53652	Gasket - Spark arrester	1
12	103746	Nut - Flexloc	1
13		Clutch, Sprocket, Drum and Bearing Assy	1
	60315	Clutch Assy	1
14	51468A	. Spring - Clutch	1
15	51464A	. Shoe - Clutch	4
16	60316	. Rotor Assy - Clutch	1
17	103718	Spring - Thrust	1
	51774B	Sprocket, Drum and Bearing Assy	1
18	103688	. Bearing - Needle	1
19	51775B	. Sprocket and Drum Assy	1
20	103879	Key - Woodruff	1
21	51420	Washer - Sprocket Assy	1
22		Bar and Chain Assy (See Figure 7)	1
23	103267	Screw - Fil hd 1/4-20 x 1 in. lg.	1
24	102130	Screw - Hex hd 1/4-20 x 1-1/2 in. lg.	2
25	101143	Nut - Hex 1/4-20	3
26	57133	Saddle - Frame	1
27	50215	Clamp - Frame	1
28	62244	Insulator - Frame	3
29	63349	Frame and Grip Assy	1
30	57565	Cover Assy - Spark plug	1
31		Oiler Tank and Fuel Tank Assy (See Figure 3)	1
32	60251A	Cover - Crankcase bottom	1
33	58166A	Gasket - Bottom	1
34	104815	Screw - Hex hd 10-24 x 7/8 in. lg. (SEMS)	4
35	101326	Nut - Hex 10-24	2
36	104815	Screw - Hex hd 10-24 x 7/8 in. lg. (SEMS)	3
37	101191	Nut - Hex 10-24	3
38	60130	Starter Assy (See Figure 2)	1
39	50581A	Guard - Sawdust	1
	53488	Fan Housing Assy	1
40	103672	. Screw - Hex hd 8-32 x 1/2 in. lg.	1
41	53490	. Wire Assy - Stop switch	1
42	59592	. Contact - Switch	1
43	59591	. Base - Switch	1
44	100057	. Lockwasher - No. 8 internal	1
45	57718	. Button - Switch	1
46		. Housing - Fan (Order Fan Housing Assy #53488)	1
47	101179	Nut - Hex 7/16 in.	1
48	101270	Washer - Special	1
49	36144B	Pin - Starter pawl	2
50	24093	Pawl - Starter	2
51	50582	Spring - Pawl	2
52	48785D	Flywheel Assy	1
53	103879	Key - Woodruff	1
54	102289	Screw - Hex hd 10-24 x 3/4 in. lg.	4
55	102189	Washer - Plain #10	3
56	55494	Screw - Sealing #10	2
57	57126A	Crankcase Cover Assy (See Figure 2)	1
	*61545A	Baffle - Spark arrester (alternate)	1

This list is continued on page 5

MODEL

450

SERIAL NO. 14001 & UP

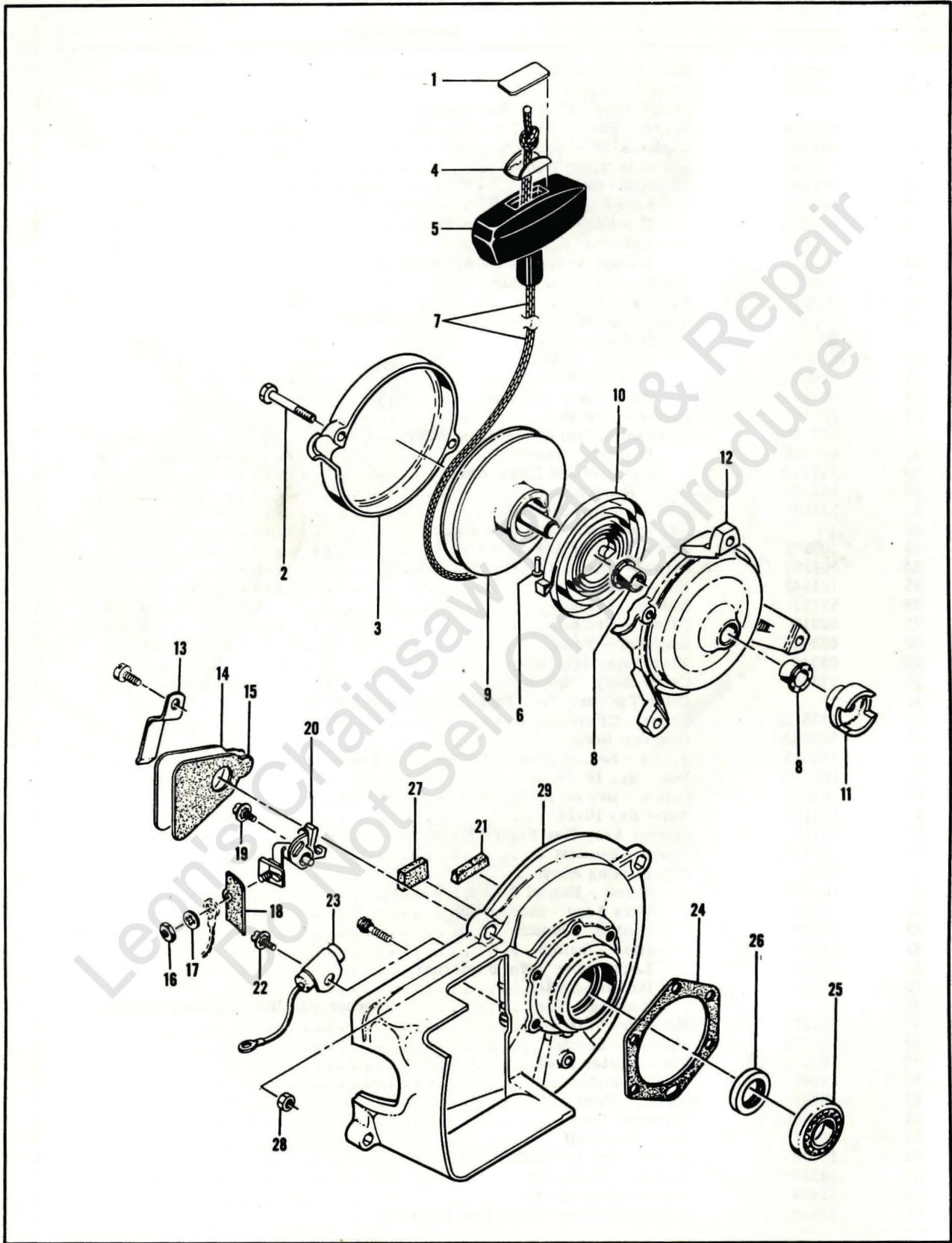

Figure 2. Starter and Crankcase Assemblies

FIGURE 1. ENGINE EXPLODED VIEW—GENERAL. (CONT)

SERIAL NO. 14001 & UP

Index No.	Part Number	Nomenclature	Units Per Assy
58	100882	Screw - Hex hd 1/4-20 x 3/4 in. lg.	2
59	100004	Washer - Plain 1/4 in.	2
60	104435	Screw - Oval hd 10-24 x 1-3/4 in. lg.	1
61		Cover and Airbox Assy (See Figure 4)	1
62	110127	Screw - Hex hd 10-24 x 7/8 in. lg. (SEMS)	4
63	101191	Nut - 10-24	1
64	50041	Brace - Handle	1
65		Reed Plate Assy and Insulator (See Figure 4)	1
66		Powerhead Assy (See Figure 6)	1

FIGURE 2. STARTER AND CRANKCASE COVER ASSEMBLIES.

Index No.	Part Number	Nomenclature	Units Per Assy
	60130	Starter Assy	1
1	57232	. Plate - Starter handle	1
2	104396	. Screw - Pan hd 10-24 x 3/4 in. lg.	2
3	60647	. Cover - Starter	1
4	57231	. Cup - Starter handle	1
5	57230	. Handle - Starter	1
6	101136	. Rivet	1
7	28716	. Rope - Starter	1
8	57535	. Bushing - Starter base	2
9	57792	. Drum - Starter	1
10	51665	. Spring - Rewind.	1
11	57790	. Ratchet - Starter	1
12	60646	. Base - Starter	1
13	50671	Retainer - Breaker box cover	1
14	50588	Cover - Breaker box	1
15	50589	Gasket - Breaker box	1
16	100251	Nut - Hex 8-32	1
17	100057	Lockwasher - No. 8 internal	1
18	50381A	Insulator - Breaker terminal	1
19	103672	Screw - 8-32 x 1/2 in. lg (SEMS)	1
20	50076A	Breaker Assy	1
21	50664	Felt - Breaker box	1
22	103672	Screw - 8-32 x 1/2 in. lg (SEMS)	1
23	50074	Condenser.	1
24	51240	Gasket - Crankcase	1
25	100824	Bearing - Ball	1
	57126A	Crankcase Cover Assy	1
26	50663	. Seal - Oil	1
27	54184	. Wiper - Felt	1
28	101326	. Nut - Hex 10-24.	2
29		. Cover - Crankcase. (Order Crankcase Cover Assy #57126A)	1

MODEL

450

SERIAL NO. 14001 & UP

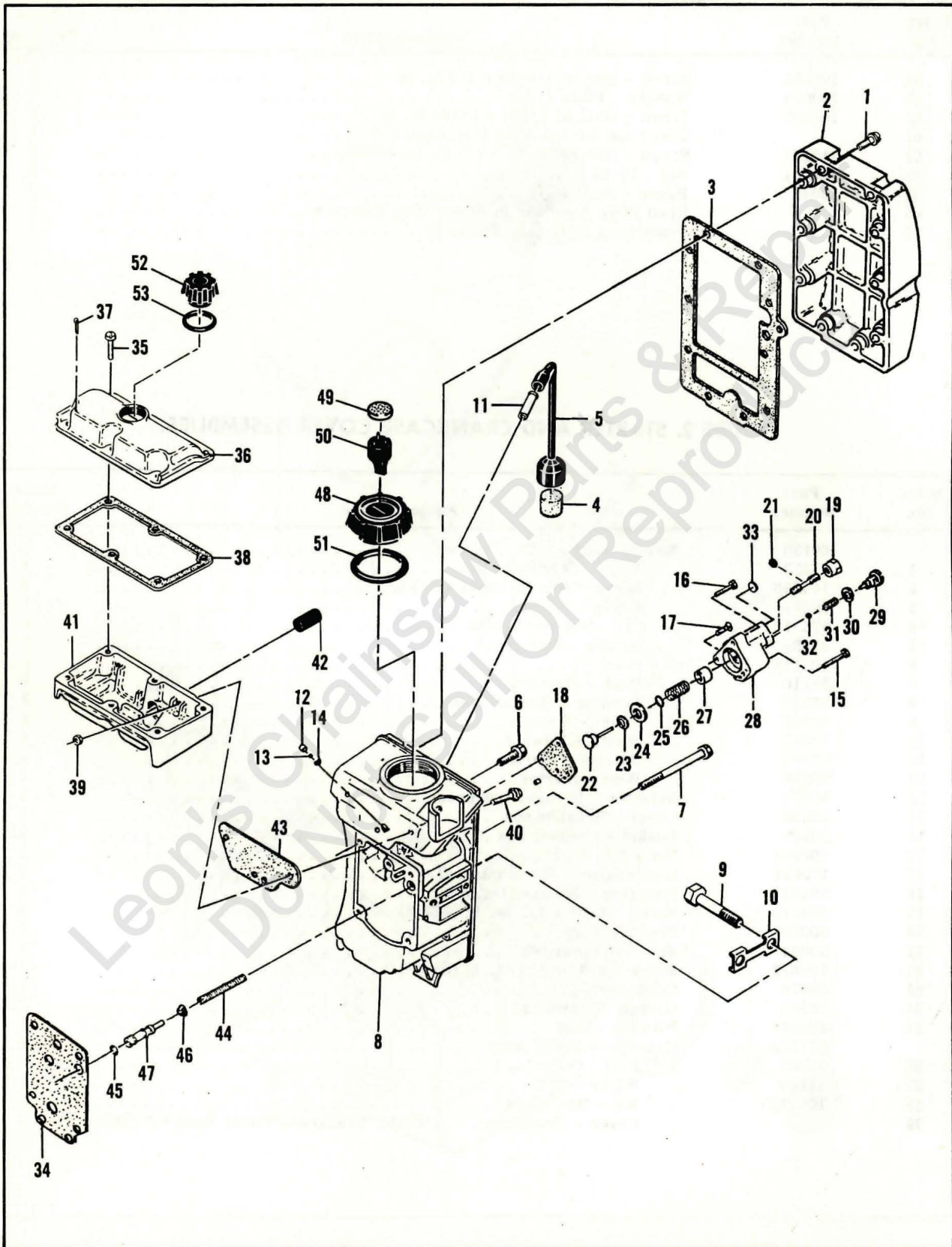

Figure 3. Oiler Tank and Fuel Tank Assemblies

FIGURE 3. OILER TANK AND FUEL TANK ASSEMBLIES

SERIAL NO. 14001 & UP

Index No.	Part Number	Nomenclature	Units Per Assy
1	104396	Screw - Pan hd 10-24 x 3/4 in. lg.	10
2	60781	Cover - Fuel tank	1
3	50034B	Gasket - Fuel tank cover	1
4	50124A	Filter - Fuel	1
5	50082	Hose - Flex	1
6	57840	Screw Assy - Sealing	3
7	50569	Screw Assy - Sealing	1
8	62154A	Fuel Tank Assy	1
9	61437	. Bolt - Bar mounting	2
10	51439	. Lockplate	1
11	28042	. Tube - Fuel hose	1
12	62216	. Seat - Ball	2
13	100071	. Ball	1
14	110327	. Ring - Retaining.	1
15	110257	Screw - Hex hd 10-24 x 1-3/4 in. lg. (SEMS)	1
16	110127	Screw - Hex hd 10-24 x 7/8 in. lg. (SEMS)	1
17	110245	Screw - Flat hd 10-24 x 3/4 in. lg.	1
18	62338B	Gasket - Pulse pump	1
	60253D	Pulse Pump Assy	1
19	60976	. Locknut - 10-24	1
20	62890	. Screw - Set 10-24 x 1-1/4 in. lg.	1
21	104001	. "O" Ring	1
22	60260A	. Piston Assy - Pulse pump	1
23	60937	. Washer - Teflon	1
24	60263	. Ring - Pulse pump	1
25	101758	. "O" Ring.	1
26	60259	. Spring - Piston	1
27	60258A	. Sleeve - Piston	1
28	60254D	. Body Assy - Pulse pump	1
29	60397A	. . Screw - Fil hd special	1
30	60398B	. . Washer	1
31	60396B	. . Spring - Ball check	1
32	102809	. . Ball - Steel 0.093 in. dia.	1
33	110157	. . Plug - Expansion 5/8 in.	1
34	60601A	Gasket - Fuel Tank	1
35	104395	Screw - Pan hd 10-24 x 5/8 in. lg.	6
36	57114A	Cover - Oil tank	1
37	100010	Pin - Cotter	1
38	57152	Gasket - Oil tank cover	1
39	101326	Nut - Hex 10-24	3
40	55494	Screw Assy - Sealing	3
41	57112A	Tank - Oiler	1
42	57279	Screen - Oiler	1
43	57147	Gasket - Oiler tank	1
44	18349A	Spring - Oiler piston	1
45	101056	"O" Ring	1
46	24104A	Cup - Oiler piston	1
47	63122	Piston - Oiler	1
48	55934B	Fuel Cap Assy	1
49	55063	. Filter - Fuel cap	1
50	53766A	. Valve - Fuel cap	1
51	101348	"O" Ring	1
52	57129A	Cap - Oil filler	1
53	101148	"O" Ring	1

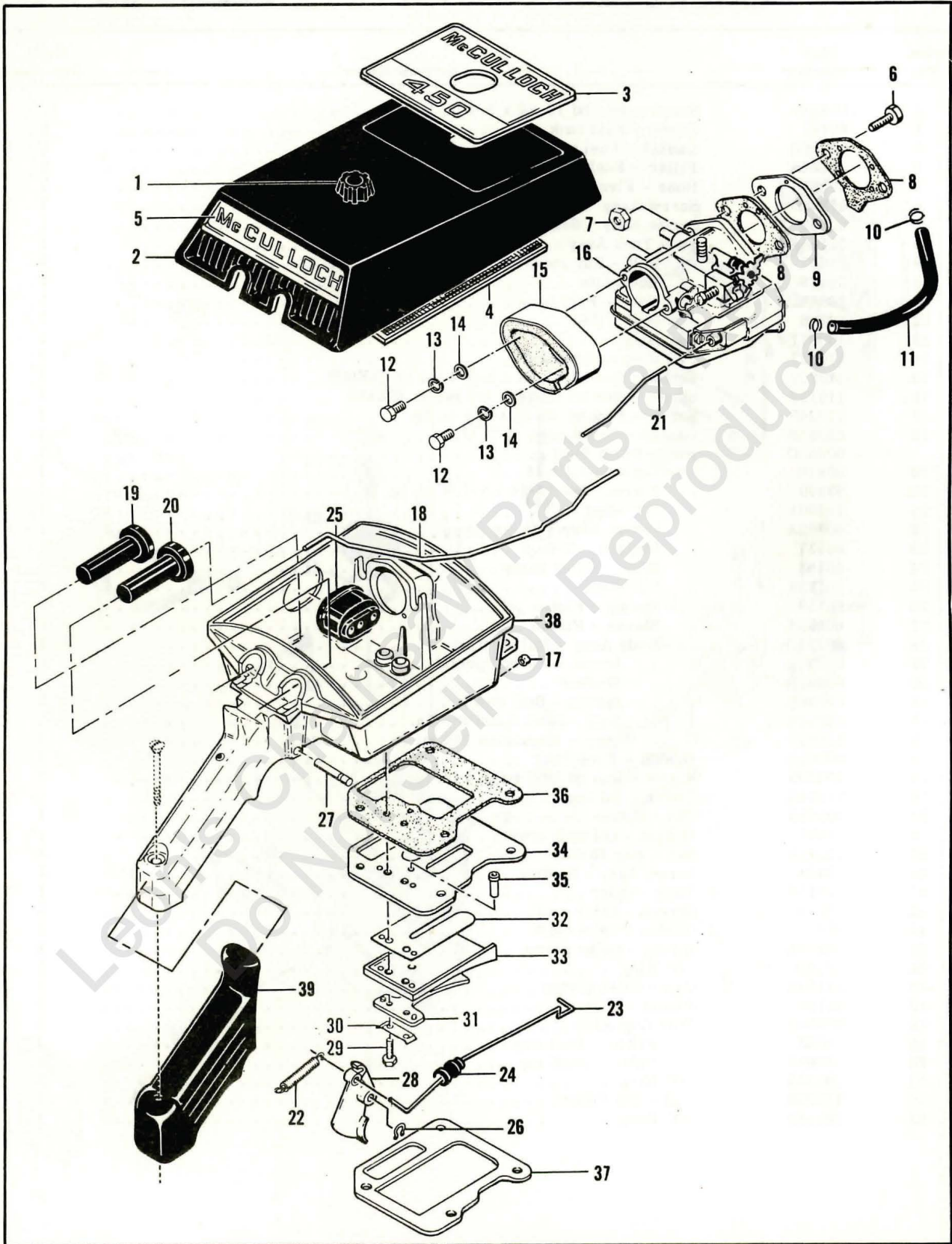

Figure 4. Cover and Airbox Assemblies

FIGURE 4. COVER AND AIRBOX ASSEMBLIES.

SERIAL NO. 14001 & UP

Index No.	Part Number	Nomenclature	Units Per Assy
	61466	Cover Assy - Air cleaner	1
1	61458A	. Knob - Air cleaner cover	1
2		. Cover - Air cleaner (Order Assy #61466)	1
3	61456	Plate - Name	1
4	55497	Screen - Air cleaner	1
5	61457A	Trim - Air cleaner cover	1
6	60208	Screw - Hex hd 1/4-20 x 7/8 in. lg.	2
7	103242	Nut - Hex 10-24	2
8	50123B	Gasket - Carburetor	2
9	53189	Adapter - Carburetor	1
10	50742	Clamp - Fuel hose	2
11	50097	Hose - Fuel	1
12	103705	Screw - Hex hd 10-32 x 9/16 in. lg.	2
13	103174	Lockwasher No. 10	2
14	102189	Washer - Plain #10	2
15	58922A	Collector Assy - Fuel	1
16	61853A	Carburetor Assy (See Figure 5)	1
17	55449A	Seal - Oiler pushrod	1
18	57866A	Pushrod - Oiler	1
19	50591B	Button - Oiler	1
20	50591B	Button - Primer	1
21	53589A	Pushrod - Primer	1
	62488	Airbox Assy	1
22	36499	. Spring - Throttle	1
23	61106	. Rod - Throttle	1
24	60237	. Grommet - Throttle rod	1
25	53277	. Grommet - Carburetor controls	1
26	104501	. Retainer - Trigger pin	1
27	50507	. Pin	1
28	50091B	. Trigger	1
29	103740	. Screw - Hex hd 8-32 x 5/8 in. lg.	2
30	51480	. Plate - Lock	1
31	57658A	. Clamp - Reed	1
32	48593	. Valve - Reed	1
33	53686A	. Deflector - Fuel	1
34	53685C	. Plate - Reed	1
35	63067	. Tube - Reed plate	1
36	57145A	. Gasket - Airbox	1
37	62834	. Insulator - Reed plate	1
38		. Airbox (Order Airbox Assy #62488)	1
39	57834	Grip - Handle	1

MODEL
450

SERIAL NO. 14001 & UP

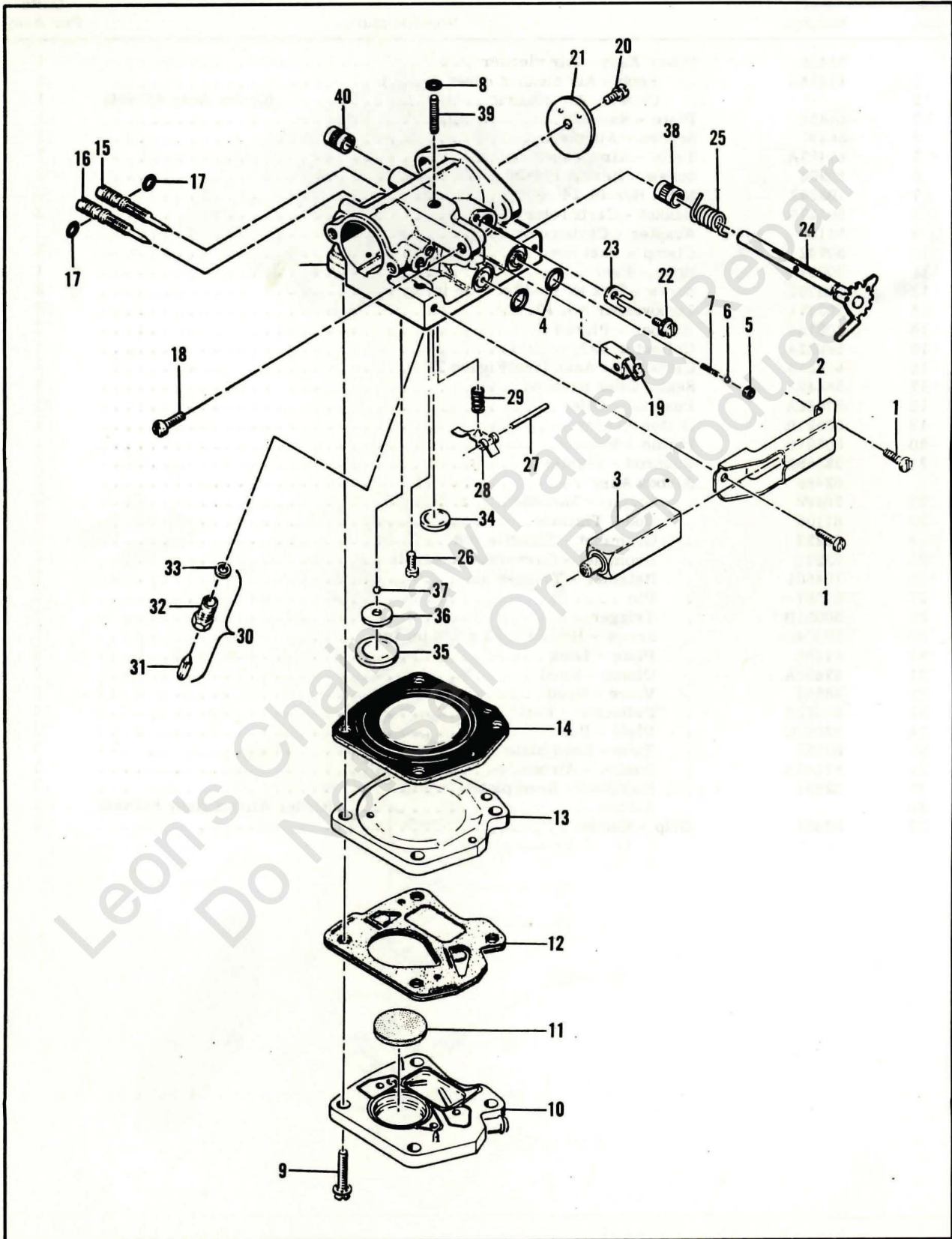

Figure 5. Carburetor Assembly

FIGURE 5. CARBURETOR ASSEMBLY.

SERIAL NO. 14001 & UP

Index No.	Part Number	Nomenclature	Units Per Assy
	61853A	Carburetor Assy	1
1	110054	. Screw - Pan hd 6-32 x 3/8 in. lg.	2
2	53440	. Bracket - Primer mounting	1
3	53449	. Primer Assy	1
4	101056	. "O" Ring	2
5	59480	. Seat - Primer valve	1
6	100302	. Ball - Steel 1/8 in.	1
7	28754	. Spring - Primer	1
8	100283	. Grommet	1
9	104520	. Screw - 10-24 x 7/8 in. lg. (SEMS)	4
10	57667	. Body Assy - Fuel pump	1
11	57277	. Filter - Fuel pump	1
12	57274B	. Diaphragm Assy - Fuel pump	1
13	48901	. Plate - Carburetor diaphragm	1
14	55067C	. Diaphragm - Carburetor	1
15	53948	. Needle - Idle adjustment	1
16	53311	. Needle - Main adjustment	1
17	104001	. "O" Ring	2
18	62910	. Screw - Idle adjusting	1
19	61108	. Guide - Throttle rod	1
20	104814	. Screw - 4-40 x 1/4 in. lg. (SEMS)	1
21	61360	. Plate - Throttle	1
22	110055	. Screw - 8-32 x 3/8 in. lg. (SEMS)	1
23	55082	. Clip - Shaft	1
24	61854A	. Shaft Assy - Throttle	1
25	61858	. Spring - Idle governor	1
26	104164	. Screw - Pan hd 4-40 x 1/4 in. lg.	1
27	104305	. Pin - Lever	1
28	55688	. Lever - Inlet control	1
29	57172	. Spring - Inlet control	1
30	60163A	. Valve Set - Needle and body	1
31	63038	. Needle - Inlet control	1
32	58969	. Body - Needle valve	1
33	55689	. Washer - Needle valve	1
	61364	. Body Assy - Carburetor	1
34	102758	. Plug - Expansion 1/2 in.	1
35	104407	. Plug - Expansion 1 in.	1
	61155	. Set - Ball and seat	1
36	61152	. Seat - Ball	1
37	61151	. Ball - Nylon 3/32 in.	1
38	55062A	. Bushing - Body	2
39	48611	. Stud	1
40		. Body (Order Body Assy #61364)	1

MODEL

450

SERIAL NO. 14001 & UP

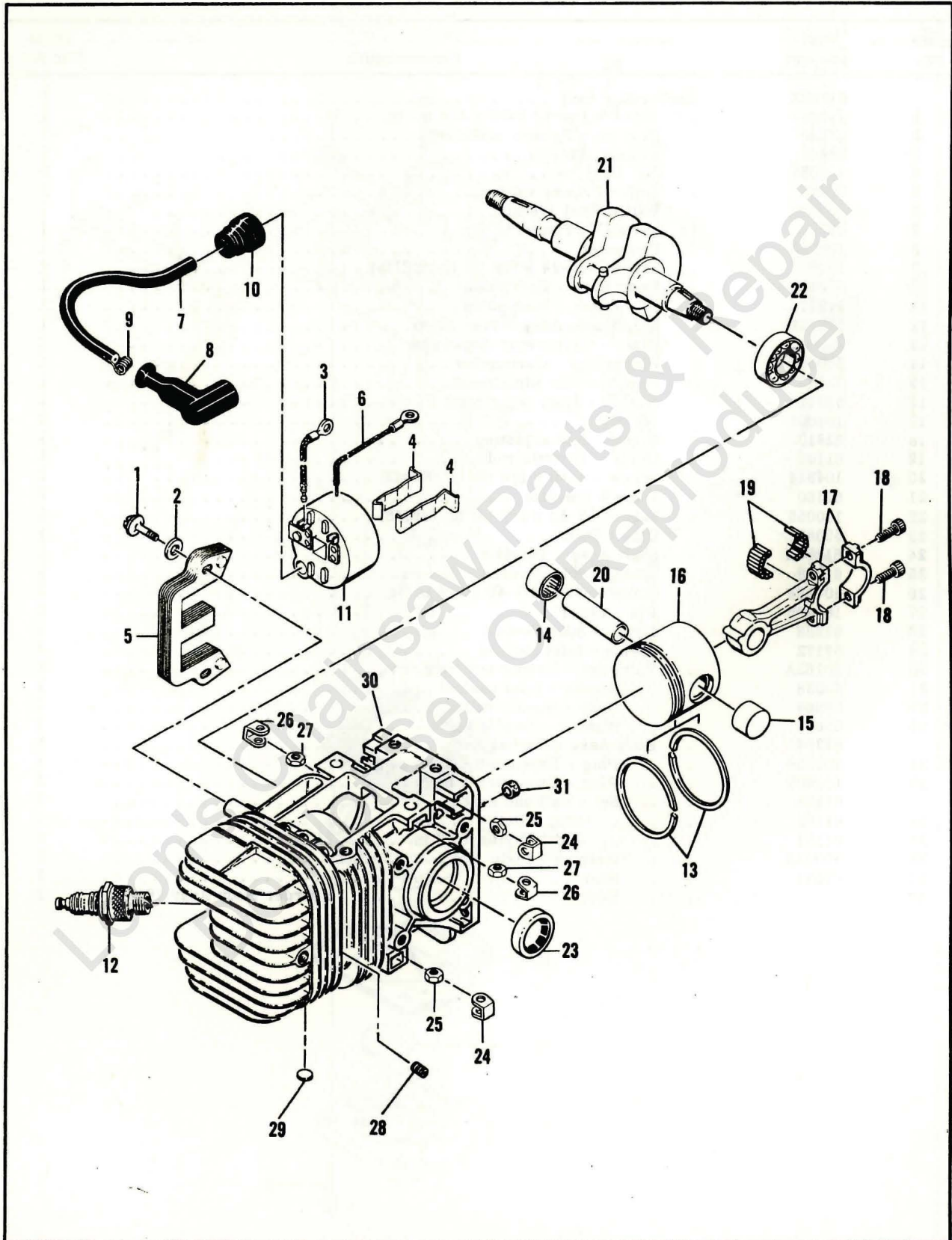

Figure 6. Powerhead Assembly

FIGURE 6. POWERHEAD ASSEMBLY.

Index No.	Part Number	Nomenclature	Units Per Assy
1	104815	Screw - Fil hd 10-24 x 7/8 in. lg.	2
2	102189	Washer - Plain #10	2
3	57225	Wire Assy - Primary	1
4	51253	Retainer - Coil	2
5	51251	Lamination Assy	1
	55949A	Coil and Terminal Assy	1
6	101883	. Wire Assy - Ground	1
7	52547	. Wire Assy - Spark plug	1
8	55060	. . Boot - Spark plug	1
9	55061	. . Connector	1
10	55617	. Nipple - Spark plug wire	1
11		. Coil Assy (Order Coil and Terminal Assy #55949A)	1
12		Spark Plug 14MM	1
	61428	Piston Assy	1
13	58881	. Ring Set - Piston	1
14	101206	. Bearing	1
15	104378	. Bearing (closed end)	1
16		. Piston (Order Piston Assy #61428)	1
17	47903	Connecting Rod Assy	1
18	60210A	. Screw - Socket hd 10-32 x 5/8 in. lg.	2
19	102742	. Roller - Needle	24
20	62831	Pin - Piston	1
21	60313A	Crankshaft	1
22	100824	Bearing - Ball	1
	62499	Crankcase Assy	1
23	104432	. Seal - Oil	1
24	18556A	. Retainer - Nut	6
25	105394	. Nut - Hex 1/4-20	6
26	28053	. Retainer - Nut	2
27	101326	. Nut - Hex 10-24	2
28	110034	. Insert - Taplok	2
29	110179	. Plug - Expansion	3
30		. Crankcase (Order Crankcase Assy #62499)	1
31	57736	Seal - Pushrod	1

OVERSIZE PISTON ASSEMBLY

Part Number	Nomenclature	Units Per Assy
61426	Piston Assy 0.020 in. oversize	1
58889	. Ring Set 0.020 in. oversize	1
101206	. Bearing	1
104378	. Bearing (closed end)	1
61427	Piston Assy 0.030 in. oversize	1
58893	. Ring Set 0.030 in. oversize	1
101206	. Bearing	1
104378	. Bearing (closed end)	1

MODEL

450

SERIAL NO. 14001 & UP

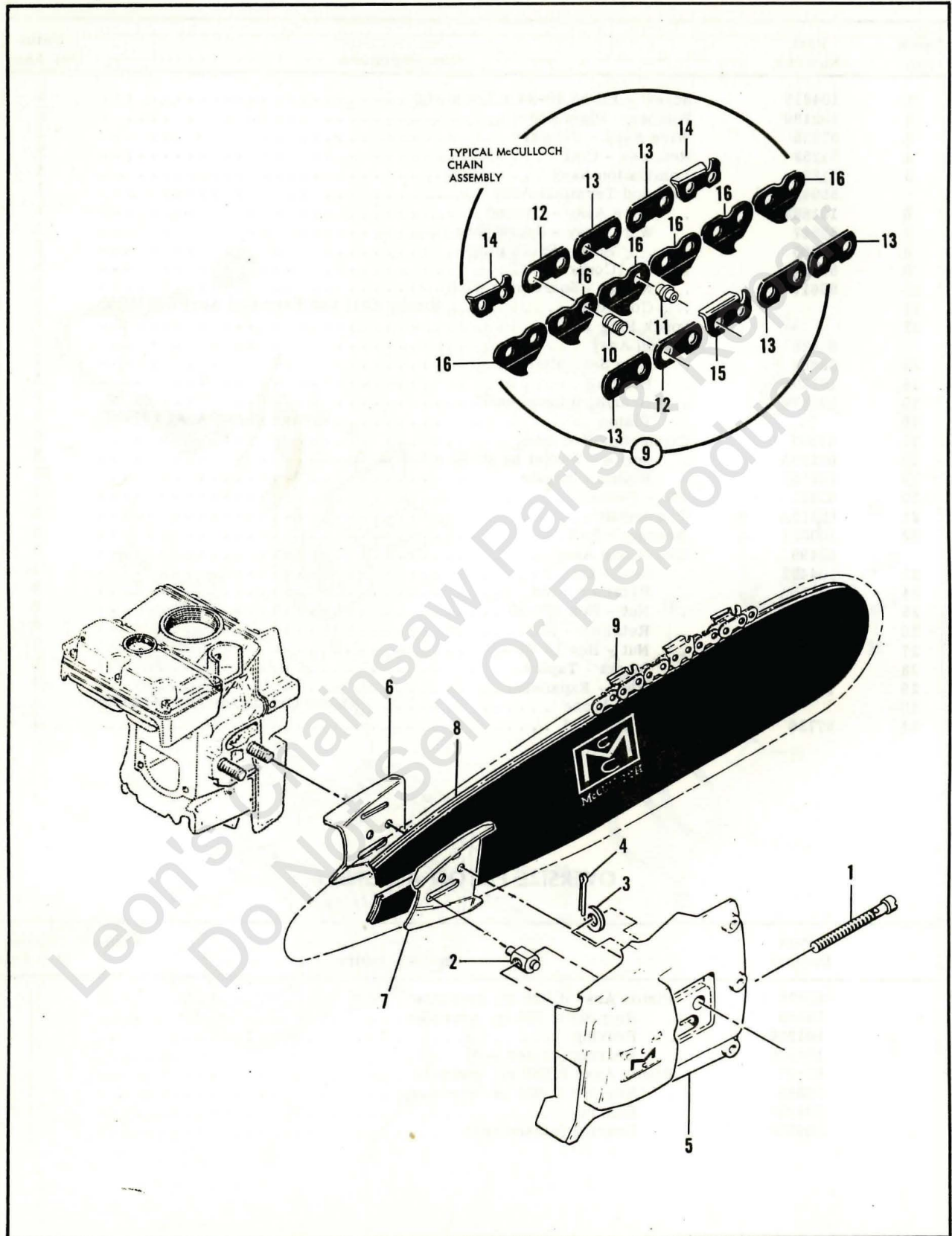

Figure 7. Clutch Guard - Bar and Chain Assemblies

FIGURE 7. CLUTCH GUARD—BAR AND CHAIN ASSEMBLIES. SERIAL NO. 14001 & UP

Index No.	Part Number	Nomenclature	Units Per Assy
	60133A	Guard Assy - Clutch	1
1	62057	. Screw - Fil hd 1/4-28 x 3-1/2 in. lg.	1
2	52207C	. Nut - Bar adjusting	1
3	100004	. Washer	1
4	105686	. Key - Cotter	1
5	60134	. Guard - Clutch	1
	61994	Set - Bar plates	1
6	61995	. Plate - Bar (L.H.)	1
7	61996	. Plate - Bar (R.H.)	1
8	51405A	Bar - Hard faced - 18 in.	1
	51407A	Bar - Hard faced - 24 in.	1
	50606	Laminated Bar - Hard faced - 12 in.	1
	50346	Laminated Bar - Hard faced - 18 in.	1
	50348	Laminated Bar - Hard faced - 24 in.	1
9		Typical McCulloch Chain Assy	
10		. Master Pin	
11		. Rivet	
12		. Master Side Link	
13		. Side Link	
14		. Cutter - Left side	
15		. Cutter - Right side	
16		. Center Link	

TOOLS AND ACCESSORIES.

Part Number	Nomenclature
*51445A	Wrench and Screwdriver Combination
*61463	Owner's Manual of Operating Instructions
56625B	Chain Maintenance Manual
57600A	Drive Unit Accessory
57610	Kit - Brushcutter Attachment
57630	Kit - Weedcutter Attachment
50275A	Earth Drill Attachment
25074B	Auger Assy - 6 inch
25075B	Auger Assy - 9 inch
61330	Kit - Spike 5-tooth
61331	Kit - Spike 4-tooth

*Items furnished with each saw.



The policy of McCulloch Corporation is one of continual improvement in design, manufacturing and engineering advancement wherever possible to assure still finer two-cycle power tools. Hence, specifications, equipment, colors, design and manufacturer's suggested list prices are subject to change without notice and McCulloch Corporation reserves the right to make such changes without prior notification or obligation to backfit or supply backfit components for units previously shipped from the factory.

Leon's Chainsaw Parts & Repair
Do Not Sell Or Repair