

MASTER ILLUSTRATED PARTS LIST

SUPER 2-10 AUTOMATIC Chain Saw

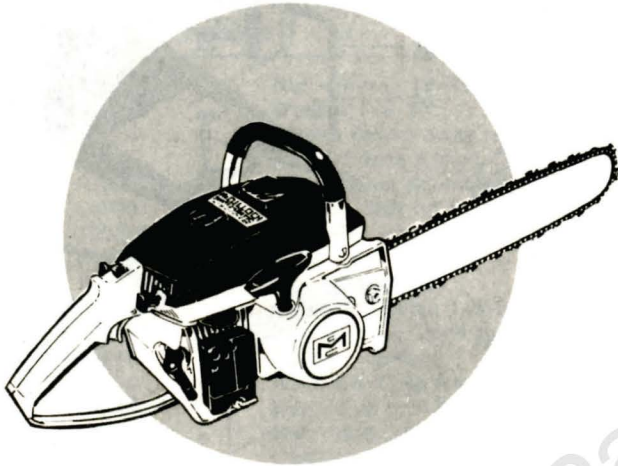

May 1970

CONTENTS

Page

The policy of McCulloch Corporation is one of continual improvement in design, manufacturing and engineering advancement wherever possible to assure still finer two-cycle power tools. Hence, specifications, equipment, colors, design and manufacturer's suggested list prices are subject to change without notice and McCulloch Corporation reserves the right to make such changes without prior notification or obligation to backfit or supply backfit components for units previously shipped from the factory.

Figure 1. General	2
Figure 2. Clutch Guard and Starter Assembly	6
Figure 3. Fuel Tank Assembly	8
Figure 4. Carburetor Assembly	10
Figure 5. Carburetor Assembly	12
Figure 6. Powerhead Assembly	14

This Master Illustrated Parts List gives the name, number and interchangeability between engines, of service and replacement parts which were used on or are presently available for all SUPER 2-10A chain saws manufactured to date.

Information about the List and how to use it will be found on the back cover.
Read the information before you start to use the List.



SUPER 2-10 AUTOMATIC

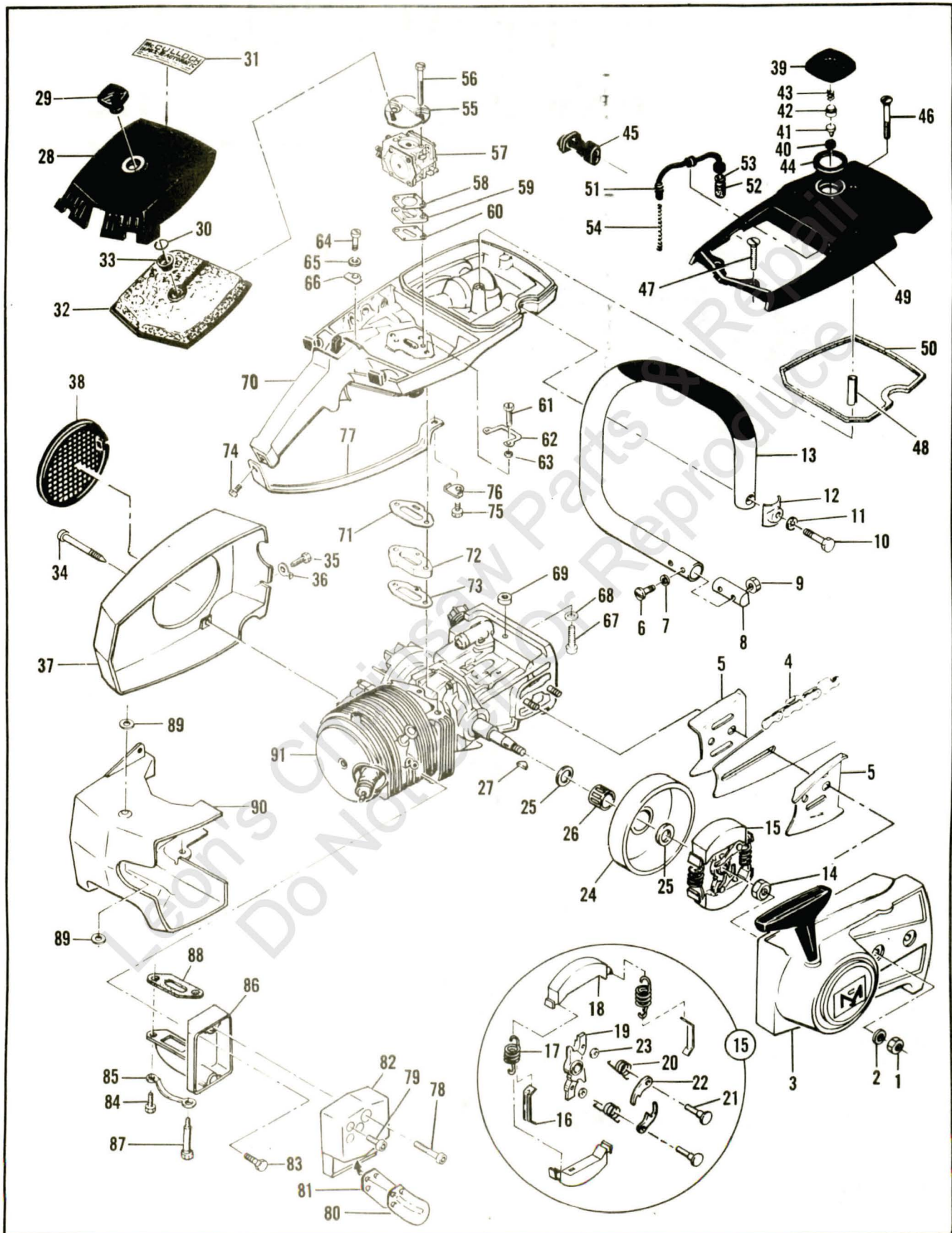

Figure 1. General

SUPER 2-10 AUTOMATIC

FIGURE 1. GENERAL

Item No.	Part Number	Description	Units Per Assy	Usable on Code												
SUPER 2-10A Usable on Code																
		<table border="1" style="width: 100%; border-collapse: collapse;"> <thead> <tr> <th style="text-align: center;">Letter</th> <th style="text-align: center;">A</th> <th style="text-align: center;">B</th> <th style="text-align: center;">C</th> <th style="text-align: center;">D</th> <th style="text-align: center;">E</th> </tr> </thead> <tbody> <tr> <td style="text-align: center;">Serial Numbers</td> <td style="text-align: center;">Prefixed 14-</td> <td style="text-align: center;">Prefixed 13-</td> <td style="text-align: center;">Prefixed 15-</td> <td style="text-align: center;">Prefixed 16-</td> <td style="text-align: center;">Prefixed 17-, A16-</td> </tr> </tbody> </table>	Letter	A	B	C	D	E	Serial Numbers	Prefixed 14-	Prefixed 13-	Prefixed 15-	Prefixed 16-	Prefixed 17-, A16-		
Letter	A	B	C	D	E											
Serial Numbers	Prefixed 14-	Prefixed 13-	Prefixed 15-	Prefixed 16-	Prefixed 17-, A16-											
1	110454	Nut - Hex 5/16-24	2	All												
2	100440	Washer - 5/16	2	All												
3		Clutch Guard Assy (see Figure 2)		All												
4		Bar & Chain Assys		All												
5	84325	Plate - Bar protector	2	All												
6	102761	Screw - Hex hd 10-24 x 7/8	2	All												
7	100352	Washer - #10	2	All												
8	61678	Plug - Nut retainer	1	All												
9	101326	Nut - Hex 10-24	2	All												
10	102130	Screw - Hex hd 1/4-20 x 1-1/2	1	All												
11	100153	Lockwasher - 1/4	1	All												
12	63484	Clamp - Frame	1	All												
13	69054	Frame & Grip Assy	1	All												
14	103746	Nut - Hex 3/8-24	1	A												
	110594	Nut - Hex 3/8-24	1	B,C,D,E												
15	67148	Clutch Assy	1	A,B												
	83224	Clutch Assy	1	C												
	83655	Clutch Assy	1	D,E												
16	64583	. Retainer	2	All												
17	66384	. Spring	2	A,B												
	83223	. Spring	2	C,D,E												
18	67233	. Shoe - Clutch	2	All												
19	67149	. Rotor Assy - Clutch	1	A,B,C												
	83671	. Rotor Assy - Clutch	1	D,E												
20	68837	. Spring - Pawl	2	A,B,C												
	83654	. Spring - Pawl	2	D,E												
21	67112	. Rivet - Pawl	2	A,B,C												
	83653	. Rivet - Pawl	2	D,E												
22	64857	. Pawl	2	A,B,C												
	24093	. Pawl	2	D,E												
23	65473	. Washer - Special	2	All												
24	65370	Kit - Sprocket	1	All												
25	61692	. Shim	2	All												
26	110330	Bearing - Sprocket	1	All												
27	103879	Key - Woodruff	1	All												
28	68530	Cover Assy - Air cleaner	1	All												
29	68529	. Knob - Cover	1	All												
30	110565	. Ring - Retaining	1	All												
31	68698	Nameplate	1	All												
32	68520	Filter Assy - Air	1	A												
	83230	Filter Assy - Air	1	B												
33	68528	. Grommet	1	A,B												
32	69922	Filter - Air	1	C,D,E												
34	62978	Screw - Special	3	All												
35	102762	Screw - Hex hd 10-24 x 1/2	1	All												
36	69890	Lockplate	1	All												
37	83521	Kit - Fan housing	1	All												
38	55615	. Guard - Flywheel	1	All												
39	68531	Cap Assy - Fuel	1	All												
40	68533	. Plug	1	All												
41	63041	. Valve	1	All												
42	62316	. Guide	1	A,B,C,D												
43	63040	. Spring	1	All												
44	69767	. Gasket	1	All												
45	84253	Boot - Carburetor adjustment	1	E												
46	110402	Screw - Oval hd 12-24 x 2-3/8	1	All												
47	103579	Screw - Fl hd 10-24 x 1	2	All												

This list continued on next page

**SUPER 2-10
AUTOMATIC**

FIGURE 1. GENERAL (CONTINUED)

Item No.	Part Number	Description	Units Per Assy	Usable on Code
48	69686	Spacer - Screw	1	All
49	69679	Cover - Fuel tank	1	A,B,C,D
	84252	Cover - Fuel tank	1	E
50	69345	Gasket - Cover	1	All
51	64848	Hose Assy - Fuel	1	All
52	63932	. Filter - Fuel	1	All
53	100440	. Washer	1	All
54	67944	Spring - Hose	1	All
55	83204	Bracket Assy	1	All
56	103357	. Screw - Hex hd 10-24 x 2-1/4	2	All
57		Carburetor Assy (see Figures 4 and 5)		All
58	68132	Gasket - Carburetor	1	A,B,C,D
	83059	Gasket - Carburetor	1	E
59	66678	Spacer - Carburetor	1	A,B,C,D
	84078	Spacer - Carburetor	1	E
60	68131	Gasket - Spacer	1	A,B,C,D
	84081	Gasket - Spacer	1	E
61	*110553	Screw - Hex hd 10-24 x 1-3/8	2	A
	110570	Screw - Hex hd 12-24 x 1-3/8	2	B,C,D,E
62	68582	Lockplate	1	All
63	102115	Washer - #12	2	All
64	*110516	Screw - Hex hd 10-24 x 1-1/8	1	A
	110568	Screw - Hex hd 12-24 x 1-1/8	1	B,C,D,E
65	64856	Washer - Special	1	All
66	68523	Lockplate	1	A
	69516	Lockplate	1	B,C,D,E
67	102660	Screw - Skt hd 10-24 x 7/8	1	All
68	100003	Washer - #10	1	All
69	*68219	Spacer - Fuel tank	1	A
	69772	Spacer - Fuel tank	1	B,C,D,E
70		Fuel Tank Assy (see Figure 3)		All
71	*68130	Gasket - Fuel tank	1	A
	68580	Gasket - Fuel tank	1	B,C,D
	84082	Gasket - Fuel tank	1	E
72	*66659	Insulator - Fuel tank	1	A
	68614	Insulator - Fuel tank	1	B,C,D
	84079	Insulator - Fuel tank	1	E
73	*68130	Gasket - Insulator	1	A
	68580	Gasket - Insulator	1	B,C,D
	84082	Gasket - Insulator	1	E
74	110353	Screw - Oval hd 10-24 x 3/8	1	A
	106078	Screw - Pan hd 10-24 x 7/16 (SEMS)	1	B,C,D,E
75	*102289	Screw - Hex hd 10-24 x 3/4	1	A
	110566	Screw - Hex hd 12-24 x 5/8	1	B,C,D,E
76	68508	Lockplate	1	All
77	69838	Brace - Handle	1	All
78	110473	Screw - Skt hd 10-24 x 1-5/8	2	A,B,C,D
	104560	Screw - Skt hd 10-24 x 1-1/2	2	E
	65532	Cover & Valve Assy	1	All
79	110472	. Screw - Skt hd 8-32 x 5/16	3	All
80	83069	. Stop - Reed valve	1	All
81	64785	. Valve - Reed	1	All
82	65419	. Cover Assy	1	All
83	110529	Screw - Hex hd 10-24 x 1/2	1	All
84	110529	Screw - Hex hd 10-24 x 1/2	1	A
	110506	Screw - Hex hd 10-24 x 5/8	1	B,C,D,E
85	67922	Lockplate	1	All
86	83106	Body & Duct Assy	1	All
87	68187	. Screw - Special	1	All
88	+ 68149	Gasket - Spark arrester	1	A,B,C,D
	± 84007	Gasket - Spark arrester (see Figure 6)	1	E

FIGURE 1. GENERAL (CONTINUED)

Item No.	Part Number	Description	Units Per Assy	Usable on Code
89	68581	Insulator - Shroud	2	All
90	67377	Shroud	1	All
91		Powerhead Assy (see Figure 6)		All

*Used on "A" coded saws with original cylinder-crankcase assembly only. Corresponding parts listed for "B", "C" and "D" coded saws must be used with service Crankcase Assembly, P/N 69779, "E" coded saws with P/N 84103.

± Used on "E" coded saws with serial numbers 10677 & up.

+ Used on "E" coded saws with serial numbers below 10677.

Master Illustrated Parts List P/N 84377 supersedes and cancels all previous lists issued for the SUPER 2-10 Automatic Saw. Discard the following lists:

IPL 68774, covering saws with serial numbers prefixed 14-

IPL 68615, covering saws with serial numbers prefixed 13-

IPL 83239, covering saws with serial numbers prefixed 15-

IPL 83682, covering saws with serial numbers prefixed 16-

SERVICE SPECIFICATIONS

Spark Plug Gap	0.025 in.
Lamination Gap	0.010 to 0.015 in.
Breaker Point Gap	0.018 in.
Torque Values	
Flywheel Nut	240 to 300 inch-pounds.
Clutch Nut	160 to 170 inch-pounds.
Connecting Rod Screws	65 to 70 inch-pounds.

SUPER 2-10
AUTOMATIC

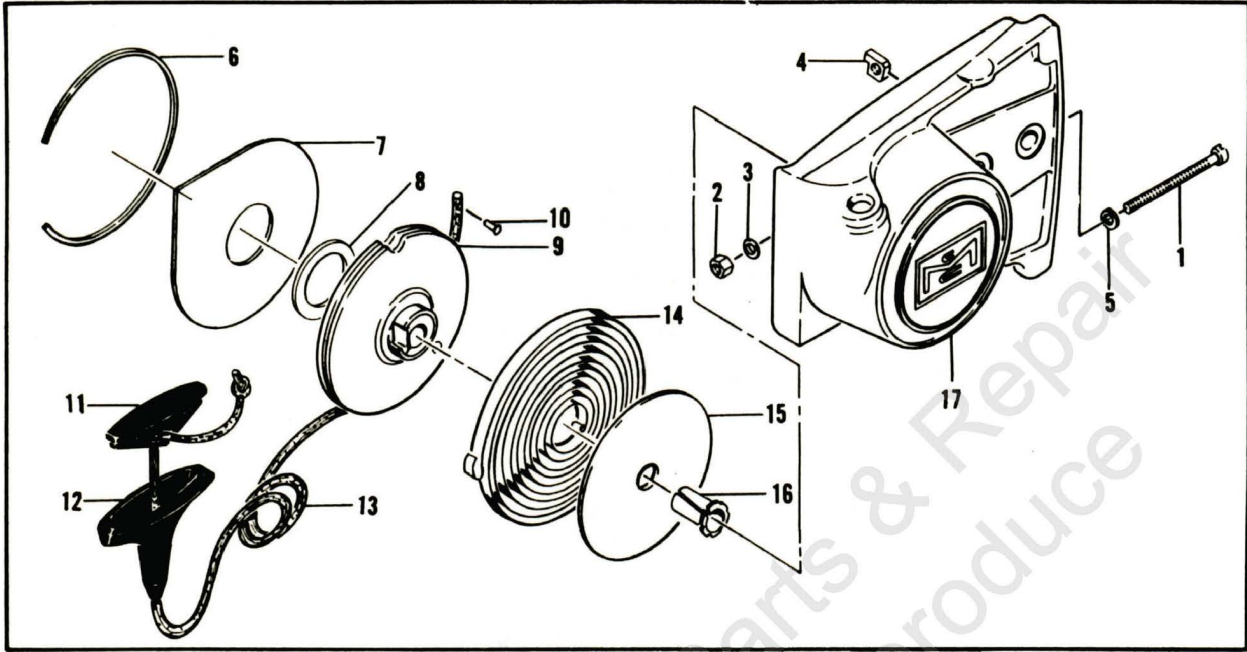

Figure 2. Clutch Guard and Starter Assembly

Leon's Chainsaw Parts & Repair
Do Not Sell Or Reproduce

SUPER 2-10 AUTOMATIC

FIGURE 2. CLUTCH GUARD AND STARTER ASSEMBLY

Item No.	Part Number	Description	Units Per Assy	Usable on Code												
SUPER 2-10A Usable on Code																
<table border="1" style="margin: auto; border-collapse: collapse;"> <thead> <tr> <th style="text-align: center;">Letter</th> <th style="text-align: center;">A</th> <th style="text-align: center;">B</th> <th style="text-align: center;">C</th> <th style="text-align: center;">D</th> <th style="text-align: center;">E</th> </tr> </thead> <tbody> <tr> <td style="text-align: center;">Serial Numbers</td> <td style="text-align: center;">Prefixed 14-</td> <td style="text-align: center;">Prefixed 13-</td> <td style="text-align: center;">Prefixed 15-</td> <td style="text-align: center;">Prefixed 16-</td> <td style="text-align: center;">Prefixed 17-, A16-</td> </tr> </tbody> </table>					Letter	A	B	C	D	E	Serial Numbers	Prefixed 14-	Prefixed 13-	Prefixed 15-	Prefixed 16-	Prefixed 17-, A16-
Letter	A	B	C	D	E											
Serial Numbers	Prefixed 14-	Prefixed 13-	Prefixed 15-	Prefixed 16-	Prefixed 17-, A16-											
	83850	Clutch Guard Assy	1	All												
1	102144	. Screw - Bar adjusting	1	All												
2	102067	. Nut - Hex 10-24	1	All												
3	110387	. Washer - Wave	1	All												
4	61705	. Nut - Bar adjusting	1	All												
5	110264	. Washer - #10	1	All												
6	67205	. Retainer - Shield	1	All												
7	63985	. Shield - Dust	1	All												
8	63986	. Washer - Thrust	1	All												
9	83651	. Drum - Starter	1	All												
10	110470	. Rivet - Rope	1	All												
11	62191A	. Insert - Handle	1	All												
12	62190A	. Handle - Starter	1	All												
13	69964	. Rope - Starter	1	All												
14	68626	. Spring - Rewind	1	A,B,C												
	83334	. Spring - Rewind	1	D,E												
15	63987	. Shield - Starter spring	1	All												
16	61635A	. Bushing - Nyliner	1	All												
17	67207	. Guard - Clutch	1	A,B,C												
	83569	. Guard - Clutch	1	D,E												

Leon's Chainsaw Parts & Repair
Do Not Sell Or Reproduce

SUPER 2-10
AUTOMATIC

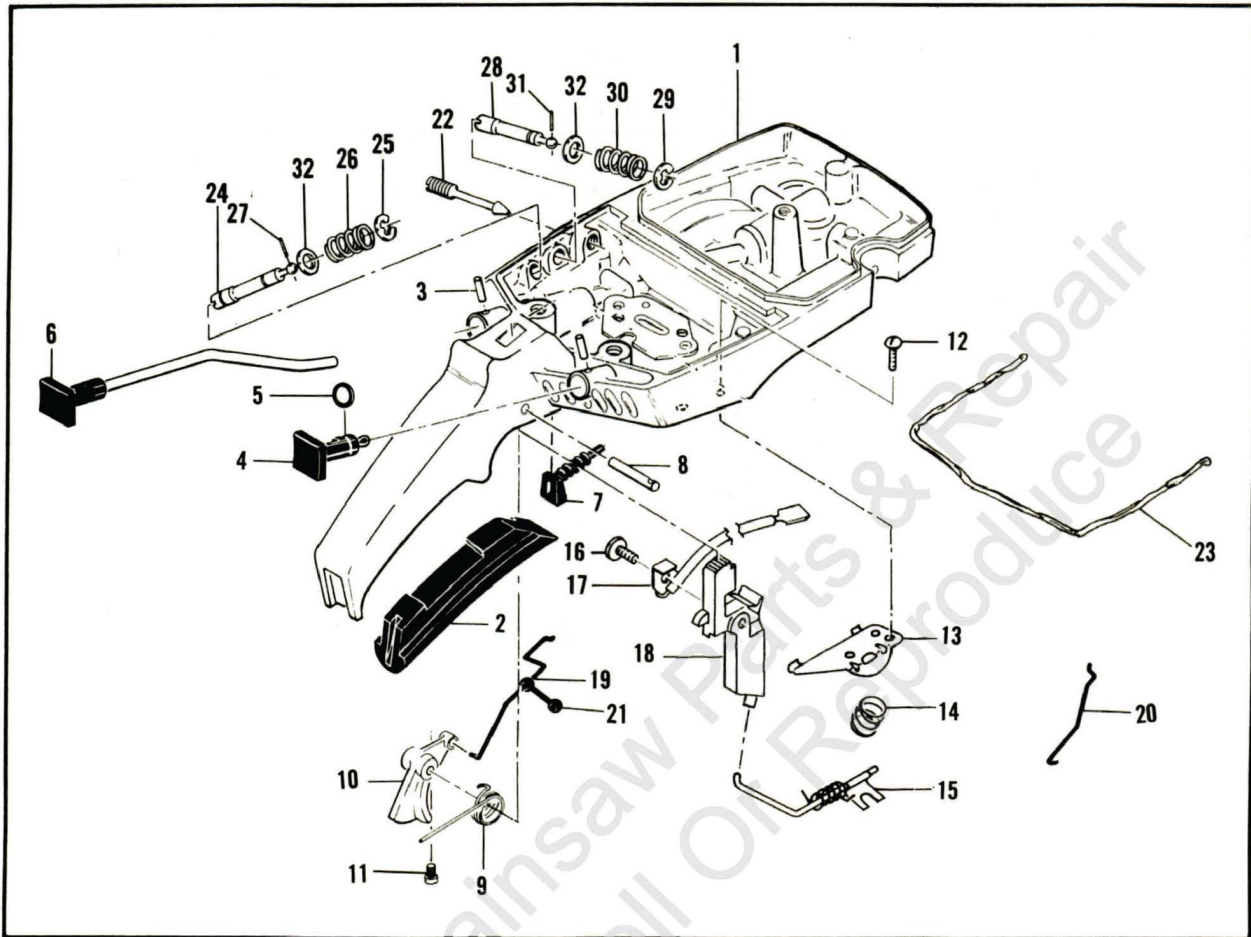

Figure 3. Fuel Tank Assembly

SUPER 2-10 AUTOMATIC

FIGURE 3. FUEL TANK ASSEMBLY

Item No.	Part Number	Description	Units Per Assy	Usable on Code												
SUPER 2-10A Usable on Code																
<table border="1" style="width: 100%; border-collapse: collapse;"> <thead> <tr> <th style="text-align: center;">Letter</th> <th style="text-align: center;">A</th> <th style="text-align: center;">B</th> <th style="text-align: center;">C</th> <th style="text-align: center;">D</th> <th style="text-align: center;">E</th> </tr> </thead> <tbody> <tr> <td style="text-align: center;">Serial Numbers</td> <td style="text-align: center;">Prefixed 14-</td> <td style="text-align: center;">Prefixed 13-</td> <td style="text-align: center;">Prefixed 15-</td> <td style="text-align: center;">Prefixed 16-</td> <td style="text-align: center;">Prefixed 17-, A16-</td> </tr> </tbody> </table>					Letter	A	B	C	D	E	Serial Numbers	Prefixed 14-	Prefixed 13-	Prefixed 15-	Prefixed 16-	Prefixed 17-, A16-
Letter	A	B	C	D	E											
Serial Numbers	Prefixed 14-	Prefixed 13-	Prefixed 15-	Prefixed 16-	Prefixed 17-, A16-											
1	68683	Fuel Tank Assy	1	A,B,C,D												
	84183	Fuel Tank Assy	1	E												
2	64872	Grip - Handle	1	All												
3	105673	Pin - Roll 3/32 x 9/16	2	All												
4	68517	Button - Choke	1	A,B												
	69041	Button - Choke	1	C,D,E												
5	101056	"O" Ring	1	All												
6	64871	Button & Rod Assy	1	All												
7	68522	Seal - Throttle rod	1	All												
8	110378	Pin - Roll 3/16 x 15/16	1	All												
9	65734	Spring - Throttle return	1	All												
10	67224	Trigger	1	All												
11	110537	Screw - Trigger adjustment	1	All												
12	105249	Screw - Rd hd 8-32 x 3/8	2	All												
13	64721	Bracket - Lever Assy	1	All												
14	69687	Spring - DSP valve	1	All												
15	69811	Lever Assy - DSP	1	All												
16	110469	Screw - Pan hd 8-32 x 5/16 s/t	1	A												
	110385	Screw - Pan hd 8-32 x 5/16	1	B,C,D,E												
17	65873	Wire Assy - Stop switch	1	All												
18	67209	Button - Control	1	All												
19	68170	Rod - Throttle	1	All												
20	67355	Rod - Choke	1	A,B												
	69042	Rod - Choke	1	C,D,E												
21	69043	Snubber - Control rod	1	C,D,E												
22	67271	Screw - Idle speed adjustment	1	All												
23	*69564	Seal - Airbox	AR	All												
24	68102	Extension Assy - High speed	1	A,B,C,D												
25	110512	. Ring - Retaining	1	A,B,C,D												
26	67363	. Spring - Extension	1	A,B,C,D												
27	110509	. Pin - Groove	1	A,B,C,D												
28	68101	Extension Assy - Idle	1	A,B,C,D												
29	110512	. Ring - Retaining	1	A,B,C,D												
30	67363	. Spring - Extension	1	A,B,C,D												
31	110509	. Pin - Groove	1	A,B,C,D												
32	67292	Washer - Special	2	A,B,C,D												

*One strip, 12-1/2 inches long, containing 9 beads of sealant (enough for 9 replacements).

SUPER 2-10 AUTOMATIC

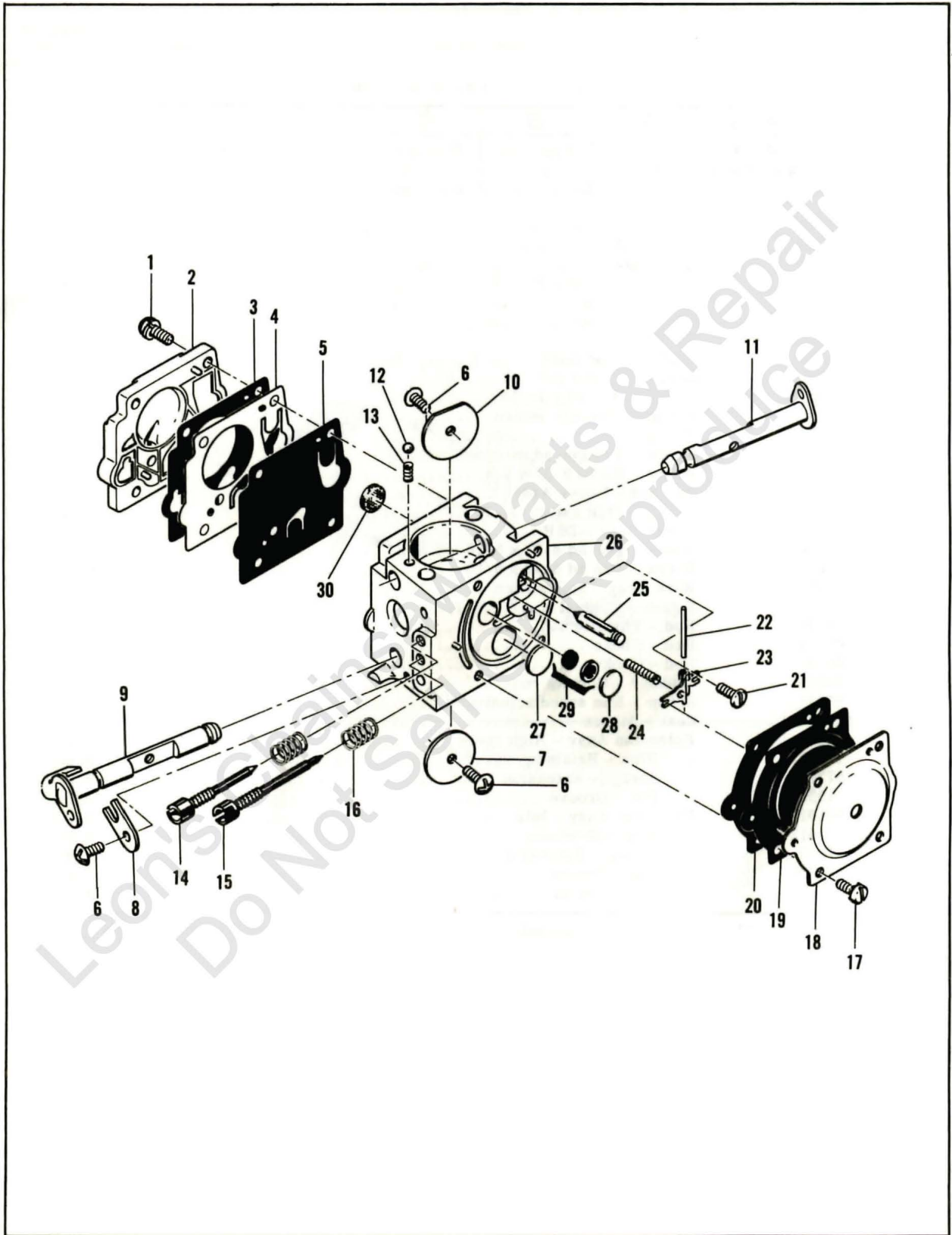

Figure 4. Carburetor Assembly

SUPER 2-10 AUTOMATIC

FIGURE 4. CARBURETOR ASSEMBLY

Item No.	Part Number	Description	Units Per Assy	Usable on Code												
SUPER 2-10A Usable on Code																
<table border="1" style="width: 100%; border-collapse: collapse;"> <thead> <tr> <th style="text-align: center;">Letter</th> <th style="text-align: center;">A</th> <th style="text-align: center;">B</th> <th style="text-align: center;">C</th> <th style="text-align: center;">D</th> <th style="text-align: center;">E</th> </tr> </thead> <tbody> <tr> <td style="text-align: center;">Serial Numbers</td> <td style="text-align: center;">Prefixed 14-</td> <td style="text-align: center;">Prefixed 13-</td> <td style="text-align: center;">Prefixed 15-</td> <td style="text-align: center;">Prefixed 16-</td> <td style="text-align: center;">Prefixed 17-, A16-</td> </tr> </tbody> </table>					Letter	A	B	C	D	E	Serial Numbers	Prefixed 14-	Prefixed 13-	Prefixed 15-	Prefixed 16-	Prefixed 17-, A16-
Letter	A	B	C	D	E											
Serial Numbers	Prefixed 14-	Prefixed 13-	Prefixed 15-	Prefixed 16-	Prefixed 17-, A16-											
	67379	Carburetor Assy (McCulloch SDC 2)	1	All												
1	67501	. Screw - Pump cover	4	All												
2	83760	. Cover - Pump	1	All												
3	*67495	. Gasket - Cover	1	All												
4	*67498	. Diaphragm - Check valve	1	All												
5	*83114	. Diaphragm - Fuel pump	1	All												
6	47690	. Screw - Plate	3	All												
7	67487	. Plate - Throttle	1	All												
8	67489	. Clip - Shaft	1	All												
9	67486	. Shaft Assy - Throttle	1	All												
10	67490	. Plate - Choke	1	All												
11	67488	. Shaft Assy - Choke	1	All												
12	*100302	. Ball - Choke friction	1	All												
13	*67504	. Spring - Choke friction	1	All												
14	*67506	. Needle - High speed	1	All												
15	*67505	. Needle - Idle	1	All												
16	*67502	. Spring - Needle	2	All												
17	70798	. Screw - Diaphragm cover	4	All												
18	83761	. Cover - Diaphragm	1	All												
19	*67499	. Diaphragm - Metering	1	All												
20	*67496	. Gasket - Diaphragm	1	All												
21	*67500	. Screw - Lever pin	1	All												
22	*67508	. Pin - Lever	1	All												
23	*67509	. Lever - Inlet	1	All												
24	*67503	. Spring - Lever	1	All												
25	*67491	. Valve - Needle	1	All												
26	67483	. Body Assy - Carburetor	1	All												
27	*71690	. Plug - 3/8	1	All												
28	*69506	. Plug - 5/16	1	All												
29	83758	. Kit - Valve & Seat Assy	1	All												
30	*67507	. Screen - Fuel	1	All												
	*67482	Gasket Set														
	67481	Repair Kit														

*Indicates parts included in Repair Kit, P/N 67481.

SUPER 2-10
AUTOMATIC

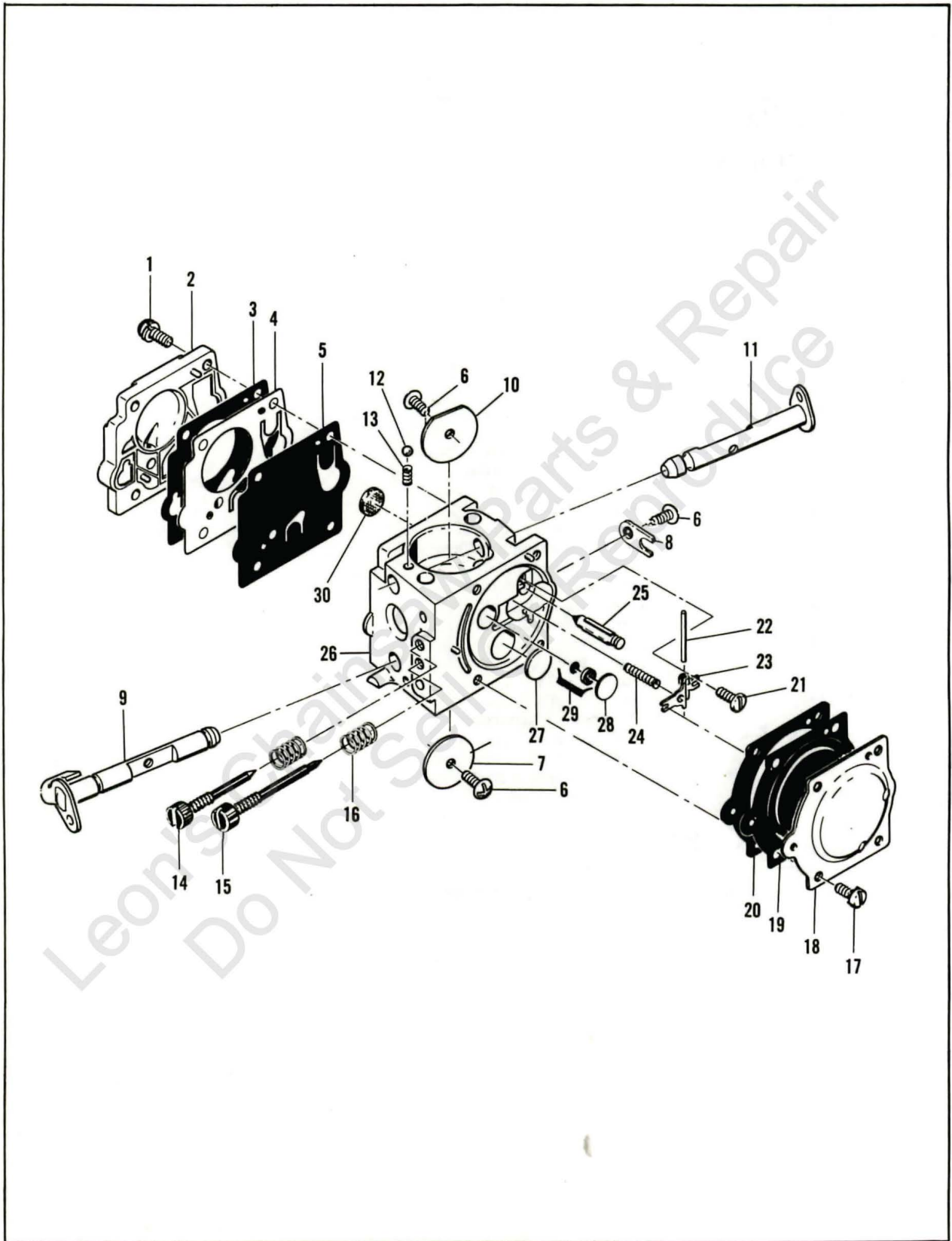

Figure 5. Carburetor Assembly

SUPER 2-10 AUTOMATIC

FIGURE 5. CARBURETOR ASSEMBLY

Item No.	Part Number	Description	Units Per Assy	Usable on Code												
SUPER 2-10A Usable on Code																
<table border="1" style="width: 100%; border-collapse: collapse;"> <thead> <tr> <th style="text-align: center;">Letter</th> <th style="text-align: center;">A</th> <th style="text-align: center;">B</th> <th style="text-align: center;">C</th> <th style="text-align: center;">D</th> <th style="text-align: center;">E</th> </tr> </thead> <tbody> <tr> <td style="text-align: center;">Serial Numbers</td> <td style="text-align: center;">Prefixed 14-</td> <td style="text-align: center;">Prefixed 13-</td> <td style="text-align: center;">Prefixed 15-</td> <td style="text-align: center;">Prefixed 16-</td> <td style="text-align: center;">Prefixed 17-, A16-</td> </tr> </tbody> </table>					Letter	A	B	C	D	E	Serial Numbers	Prefixed 14-	Prefixed 13-	Prefixed 15-	Prefixed 16-	Prefixed 17-, A16-
Letter	A	B	C	D	E											
Serial Numbers	Prefixed 14-	Prefixed 13-	Prefixed 15-	Prefixed 16-	Prefixed 17-, A16-											
	†69942	Carburetor Assy (McCulloch SDC 18)	1	E												
1	67501	. Screw - Pump cover	4	E												
2	83760	. Cover - Pump	1	E												
3	*67495	. Gasket - Cover	1	E												
4	*67498	. Diaphragm - Check valve	1	E												
5	*83114	. Diaphragm - Fuel pump	1	E												
6	47690	. Screw - Plate	3	E												
7	83762	. Plate - Throttle	1	E												
8	67489	. Clip - Shaft	1	E												
9	67486	. Shaft Assy - Throttle	1	E												
10	67490	. Plate - Choke	1	E												
11	67488	. Shaft Assy - Choke	1	E												
12	*100302	. Ball - Choke friction	1	E												
13	*67504	. Spring - Choke friction	1	E												
14	*68104	. Needle - High speed	1	E												
15	*68105	. Needle - Idle	1	E												
16	*67502	. Spring - Needle	2	E												
17	70798	. Screw - Diaphragm cover	4	E												
18	83761	. Cover - Diaphragm	1	E												
19	*67499	. Diaphragm - Metering	1	E												
20	*67496	. Gasket - Diaphragm	1	E												
21	*67500	. Screw - Lever pin	1	E												
22	*67508	. Pin - Lever	1	E												
23	*67509	. Lever - Inlet	1	E												
24	*67503	. Spring - Lever	1	E												
25	*67491	. Valve - Needle	1	E												
26	83759	. Body Assy - Carburetor	1	E												
27	*71690	. Plug - 3/8	1	E												
28	*69506	. Plug - 5/16	1	E												
29	83758	. Kit - Valve & Seat Assy	1	E												
30	*67507	. Screen - Fuel	1	E												
	*67482	Gasket Set														
	83764	Repair Kit														

*Indicates parts included in Repair Kit, P/N 83764.

†Order parts for "E" coded saws using Carburetor Assy, P/N 69942. See fuel pump cover for carburetor identification.

SUPER 2-10 AUTOMATIC

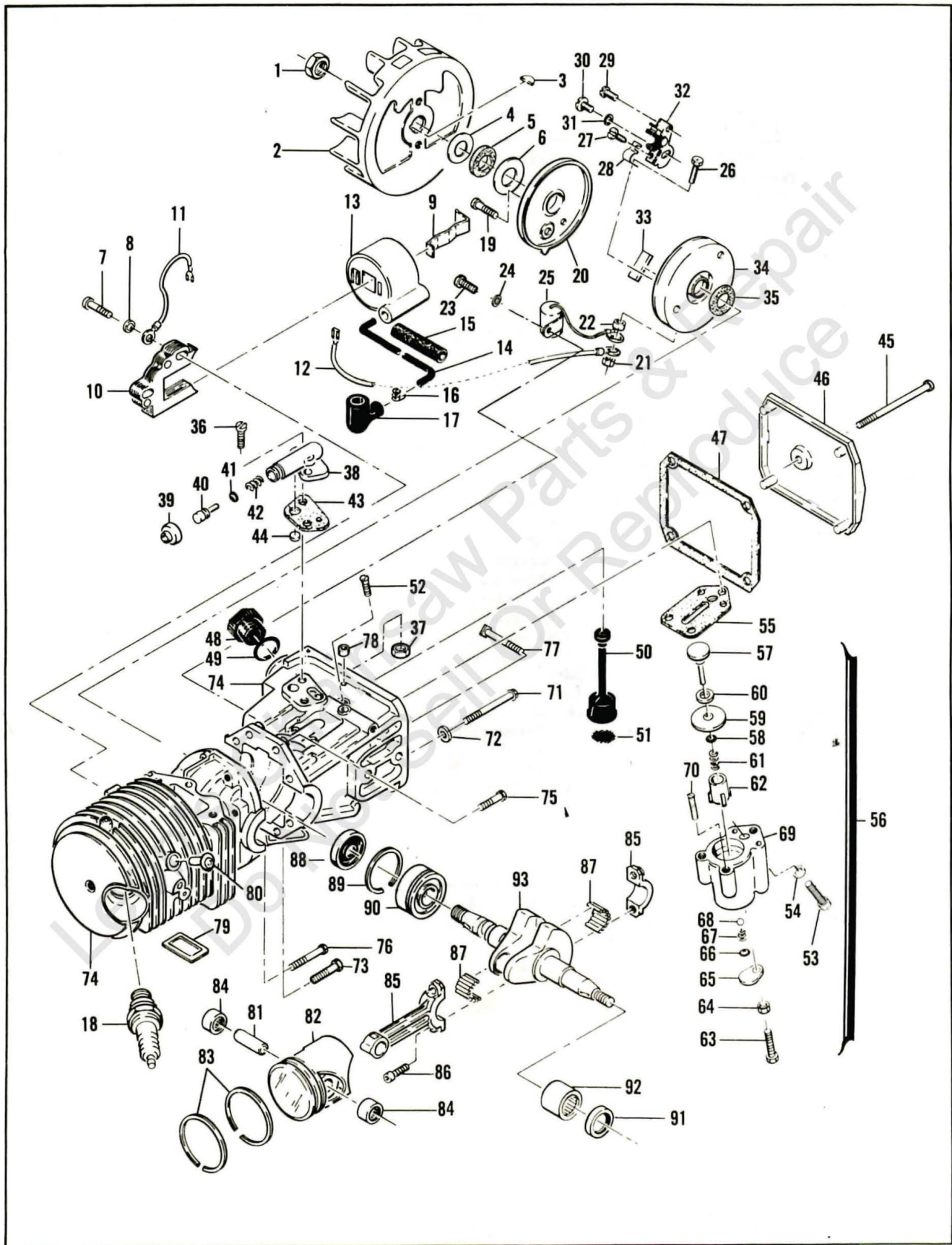

Figure 6. Powerhead Assembly

SUPER 2-10 AUTOMATIC

FIGURE 6. POWERHEAD ASSEMBLY

Item No.	Part Number	Description	Units Per Assy	Usable on Code												
SUPER 2-10A Usable on Code																
		<table border="1" style="width: 100%; border-collapse: collapse;"> <thead> <tr> <th style="text-align: center;">Letter</th> <th style="text-align: center;">A</th> <th style="text-align: center;">B</th> <th style="text-align: center;">C</th> <th style="text-align: center;">D</th> <th style="text-align: center;">E</th> </tr> </thead> <tbody> <tr> <td style="text-align: center;">Serial Numbers</td> <td style="text-align: center;">Prefixed 14-</td> <td style="text-align: center;">Prefixed 13-</td> <td style="text-align: center;">Prefixed 15-</td> <td style="text-align: center;">Prefixed 16-</td> <td style="text-align: center;">Prefixed 17-, A16-</td> </tr> </tbody> </table>	Letter	A	B	C	D	E	Serial Numbers	Prefixed 14-	Prefixed 13-	Prefixed 15-	Prefixed 16-	Prefixed 17-, A16-		
Letter	A	B	C	D	E											
Serial Numbers	Prefixed 14-	Prefixed 13-	Prefixed 15-	Prefixed 16-	Prefixed 17-, A16-											
1	110594	Nut - Hex 3/8-24	1	All												
2	61737A	Flywheel Assy	1	All												
3	103879	Key - Woodruff	1	All												
4	67057	Washer - Thrust	1	All												
5	67056	Seal	1	All												
6	67054	Washer - Thrust	1	All												
7	110127	Screw - Hex hd 10-24 x 7/8 (SEMS)	2	All												
8	100003	Washer - #10	2	All												
9	51253	Retainer - Coil	1	All												
10	68164	Lamination Assy	1	All												
11	62819	Wire Assy - Ground	1	All												
12	69344	Wire Assy - Primary	1	All												
13	69798	Coil & Terminal Assy	1	All												
14	69966	. Wire & Sleeve Assy - Spark plug	1	All												
15	67127	. . Sleeve	1	All												
16	62932	. . Connector	1	All												
17	62926	. . Boot	1	All												
18	63097	Spark Plug - AC CS45T	1	All												
19	110349	Screw - Rd hd 8-32 x 3/4	1	All												
20	62362	Cover - Breaker box	1	All												
21	100298	Nut - Hex 6-32	1	All												
22	62365	Spacer - Breaker screw	1	All												
23	105249	Screw - Rd hd 8-32 x 3/8 (SEMS)	1	A												
	110623	Screw - Fil hd 8-32 x 1/2 (SEMS)	1	B												
	103672	Screw - Fil hd 8-32 x 1/2	1	C,D,E												
24	100080	Washer - #8	1	All												
25	61650	Condenser	1	All												
26	110346	Screw - Hex hd 6-32 x 3/4	1	All												
27	110489	Screw - Pan hd 6-32 x 7/16 s/t	1	C,D,E												
28	83126	Strap - Conductor	1	C,D,E												
29	100934	Screw - Rd hd 8-32 x 3/8	1	All												
30	100934	Screw - Rd hd 8-32 x 3/8	1	A												
	110445	Screw - Truss hd 8-32 x 3/8	1	B,C,D,E												
31	105976	Washer - #8	1	All												
32	62363	Breaker Assy	1	A,B												
	66231	Breaker Assy	1	C,D,E												
33	54184	Wiper - Cam	1	All												
34	62361	Box - Breaker	1	A,B												
	83125	Box - Breaker	1	C,D,E												
35	67051	Seal - Box	1	All												
36	110623	Screw - Hex hd 8-32 x 1/2	2	All												
37	100955	Nut - Hex 8-32	1	All												
38	62261A	Housing - Pump	1	All												
39	62262	Cap - Housing	1	All												
40	62266	Plunger - Pump	1	All												
41	101056	"O" Ring	1	All												
42	66687	Spring - Plunger	1	All												
43	62230	Gasket - Pump	1	All												
44	62909	Valve - Pump	1	All												
45	110291	Screw - Pan hd 10-24 x 2-5/8	1	All												
46	63072	Cover - Oil tank	1	All												
47	62116	Gasket - Cover	1	All												
48	57129A	Cap - Oil tank	1	A,B												
	68809	Cap - Oil tank	1	C,D,E												
49	101148	"O" Ring	1	All												
50	62123B	Hose Assy - Oil	1	All												

This list is continued on next page

SUPER 2-10 AUTOMATIC

FIGURE 6. POWERHEAD ASSEMBLY (CONTINUED)

Item No.	Part Number	Description	Units Per Assy	Usable on Code
51	51506	. Screen - Hose	1	All
52	+ 110333	Screw - Oval hd 8-32 x 1/2	3	A,B,C,D
53	± 102660	Screw - Skt hd 10-24 x 7/8	1	E
54	± 24236	Washer - Special	1	E
55	+ 62274	Gasket - Pulse pump	1	A,B,C,D
	± 83790	Gasket - Pulse pump	1	E
56	+ 83134	Pump Assy - Pulse	1	A,B,C,D
	± 83786	Pump Assy - Pulse	1	E
57	60260A	. Piston Assy - Pump	1	All
58	104001	. "O" Ring	1	All
59	60263	. Ring - Pump piston	1	All
60	60937	. Washer - Teflon	1	All
61	60259	. Spring - Piston	1	All
62	62227	. Sleeve - Adjustment	1	All
63	110386	. Screw - Hex hd 8-32 x 1	1	All
64	100251	. Nut - Hex 8-32	1	All
65	62407	. Cover - Outlet valve	1	All
66	106104	. "O" Ring	1	All
67	62885A	. Spring - Outlet valve	1	All
68	102809	. Ball	1	All
69	+ 83128	. Body Assy - Pump	1	A,B,C,D
	± 83787	. Body Assy - Pump	1	E
70	± 110643	. Screw - Set 8-32 x 7/16	1	E
71	62105	Screw Assy - Sealing	4	All
72	62842	. Washer - Sealing	4	All
73	110288	Screw - Hex hd 8-32 x 3/4	1	All
74	+ 69779	Crankcase Assy	1	A,B,C,D
	± 84103	Crankcase Assy	1	E
75	110288	. Screw - Hex hd 8-32 x 3/4	2	All
76	*110618	. Screw - Hex hd 8-32 x 1-3/8	1	All
77	62065	. Bolt - Bar mounting	2	All
78	*69772	. Spacer - Fuel tank	1	All
79	± *84007	. Gasket - Muffler	1	E
80	± *84217	. Valve - DSP	1	E
	+ 83166	Valve - DSP	1	A,B,C,D
81	61649	Pin - Piston	1	All
82	69212	Piston Assy	1	All
83	62814	. Ring Set - Piston	1	All
84	103512	. Bearing - Needle	2	A,B,C,D
	103085	. Bearing - Needle	2	E
85	65401	Connecting Rod Assy	1	All
86	61627A	. Screw - Skt hd special	2	All
87	63225	. Roller - Needle (set of 20)	1	All
88	65746	Seal - Oil	1	A
	67906	Seal - Oil	1	B,C,D,E
89	63464	Ring - Snap	1	All
90	63429B	Bearing - Ball	1	A
	67905	Bearing - Ball	1	B,C,D,E
91	65747	Seal - Oil	1	B,D
	110260	Seal - Oil	1	A,C,E
92	104357	Bearing - Needle	1	All
93	63336	Crankshaft	1	All

*Not included with Crankcase Assy, P/N 69779.

+ Used on "E" coded saws with serial numbers below 10677.

± Used on "E" coded saws with serial numbers 10677 & up.

SUPER 2-10 AUTOMATIC

ACCESSORIES

Item No.	Part Number	Description	Units Per Assy	Usable on Code												
SUPER 2-10A Usable on Code																
<table border="1" style="margin: auto; border-collapse: collapse;"> <thead> <tr> <th style="text-align: center;">Letter</th> <th style="text-align: center;">A</th> <th style="text-align: center;">B</th> <th style="text-align: center;">C</th> <th style="text-align: center;">D</th> <th style="text-align: center;">E</th> </tr> </thead> <tbody> <tr> <td style="text-align: center;">Serial Numbers</td> <td style="text-align: center;">Prefixed 14-</td> <td style="text-align: center;">Prefixed 13-</td> <td style="text-align: center;">Prefixed 15-</td> <td style="text-align: center;">Prefixed 16-</td> <td style="text-align: center;">Prefixed 17-, A16-</td> </tr> </tbody> </table>					Letter	A	B	C	D	E	Serial Numbers	Prefixed 14-	Prefixed 13-	Prefixed 15-	Prefixed 16-	Prefixed 17-, A16-
Letter	A	B	C	D	E											
Serial Numbers	Prefixed 14-	Prefixed 13-	Prefixed 15-	Prefixed 16-	Prefixed 17-, A16-											
69210		Piston Assy - 0.020 in. oversize		All												
62813		. Ring Set - Piston 0.020 in. oversize		All												
69211		Piston Assy - 0.030 in. oversize		All												
62812		. Ring Set - Piston 0.030 in. oversize		All												
63341A		Kit - Spike		All												
69058		Kit - Wrap-around frame		All												
69191		Kit - Pressure test adaptor		All												
63432		Spark Plug - AC CS42T		All												
65778		Spark Plug - AC CS41T		All												
65712		Guide - Timing		All												
65325		Baffle - Spark arrester		All												
63746		Scrench		All												
62827		Wrench - Screwdriver		All												
68965		Manual - Owners		A,B												
83434		Manual - Owners		C,D												
84220		Manual - Owners		E												

Leon's Chainsaw Parts & Repair
Do Not Sell Or Reproduce

SUPER 2-10 AUTOMATIC

40:1 TWO-CYCLE MOTOR OIL



6 oz. can #78960
6-pack #78961
16 oz. can #78963
6-pack #78964
1 qt. bottle #110626

Reduces smoke,
carbon and engine wear.

CHAIN, BAR AND SPROCKET OIL



1 qt. bottle #110631
Case of 24 #110632

Specially designed for
extra lubrication of bars
and chains.

BAR GUARDS

Protect bar and chain
from accidental
damage.



A B
Black Polyvinylchloride

(A) for wide bars #56927
(B) narrow bars #64930



C D
Rigid Yellow Plastic

(C) MAC 10-16, 20" #66544
(D) PM6-12, 16" #83124

LOCQUIC AND

Primer. Cleans,
degreases, and
accelerates curing.

7-1/2 oz. spray can.
#69794



LOCTITE

Sealant, bonding
agent

10cc plastic
bottle
#67537



SPRAY PAINT

Black

12 oz. can #103503
Case of 12 #103400



Yellow

12 oz. can #102449
Case of 12 #102464

STARTER ROPE

Solid, braided nylon



100' spool

#36825

CHAIN SHARPENING TOOLS

The ● shows which tools are used on chains		S-25	SM-57	S-40	S-80	S-90
McCULLOCH FILES 	1/8" round	●				
	5/32" round	●	●			
	3/16" round		●			
	7/32" round			●		
	1/4" round				●	
	9/32" round					●
	8" flat	●	●	●	●	●
6" flat safety	●	●	●	●	●	
FILE GUIDE & FILE 						
#67750 (1/8" round)		●				
#60950 (7/32" round) (Also holds 3/16 and 1/4" round)			●	●		
DEPTH GAUGE TOOLS 						
#56241	.045-.060"			●	●	●
#64198	.035-.060"		●	●	●	●
#64359	.045-.050"		●	●	●	●
#67688	.015-.020"	●				
#67680	.025-.030"	●	●	●	●	●
FILE-N-JOINT Assures correct filing angle, height. 						
	#61034	●	●	●	●	●

"BREAK ALL" CHAIN BREAKER

Required when
repairing chain.

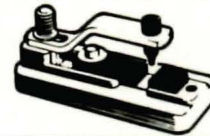

#61753
Instructions
included.

PRESSURE TEST TOOLS

For leakage check
of crankcase,
fuel system.



Basic unit
#62849

The information contained in this Master Illustrated Parts List is based on original Illustrated Parts Lists, Engineering Records and the Master Parts Price List and is accurate to the best of our knowledge.

Each chain saw model is given a code letter. Whenever the code letter appears in the right hand column, the part is used on the engines of the model for which the code letter stands. When a part is used on all models covered in the Master Illustrated Parts List, the word "All" appears in the right-hand column instead of the code letters.

Names of parts have been checked and made to agree with the names given in the Master Parts Price List except in a very few cases where additional nomenclature was required.

The illustrations of the individual parts do not necessarily picture all the differences between parts with the same item number because the illustrations would be too complicated for use if they did. Instead, the illustration shows a representative part for each item number.



McCULLOCH



● MANUFACTURING ● SALES ● SERVICE ●

McCULLOCH CORPORATION

6101 WEST CENTURY BLVD., LOS ANGELES, CALIFORNIA 90045

INTERNATIONAL DIVISIONS:

LOS ANGELES, CALIF., P. O. BOX 45466

HONG KONG, B. C. C.: G. P. O. BOX 879

McCULLOCH OF CANADA LTD.

6338 VISCOUNT ROAD, MALTON, ONTARIO, CANADA

McCULLOCH OF EUROPE, N. V.

ANTOON SPINOYSTRAAT, 5, B-2800 MECHELEN, BELGIUM

McCULLOCH OF AUSTRALIA PTY., LTD.

P.O. BOX 223, SEVEN HILLS, N.S.W. 2147, AUSTRALIA