

MAC 7-10A Chain Saw

MODEL 600052 - SERIAL NUMBERS PREFIXED 10-

ILLUSTRATED PARTS LIST

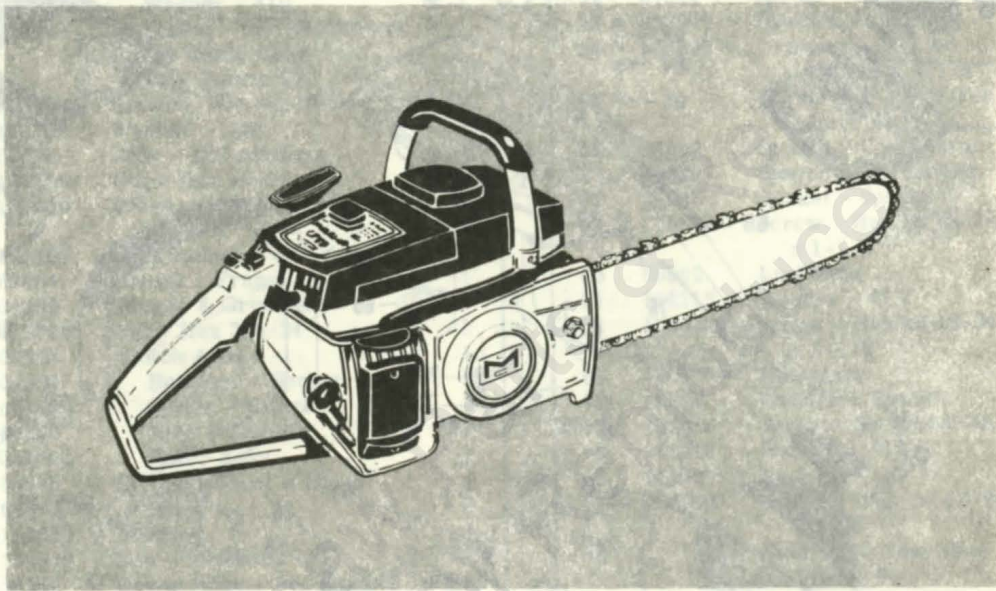

OCTOBER 1970

The policy of McCulloch Corporation is one of continual improvement in design, manufacturing and engineering advancement wherever possible to assure still finer two-cycle power tools. Hence, specifications, equipment, colors, design and manufacturer's suggested list prices are subject to change without notice and McCulloch Corporation reserves the right to make such changes without prior notification or obligation to backfit or supply backfit components for units previously shipped from the factory.

	Page
Figure 1. General	2
Figure 2. Fan Housing & Starter Assemblies	4
Figure 3. Fuel Tank Assembly	4
Figure 4. Carburetor Assembly	6
Figure 5. Powerhead Assembly	8
Figure 6. Bar & Chain Assembly	10

 **McCULLOCH**

MAC 7-10A

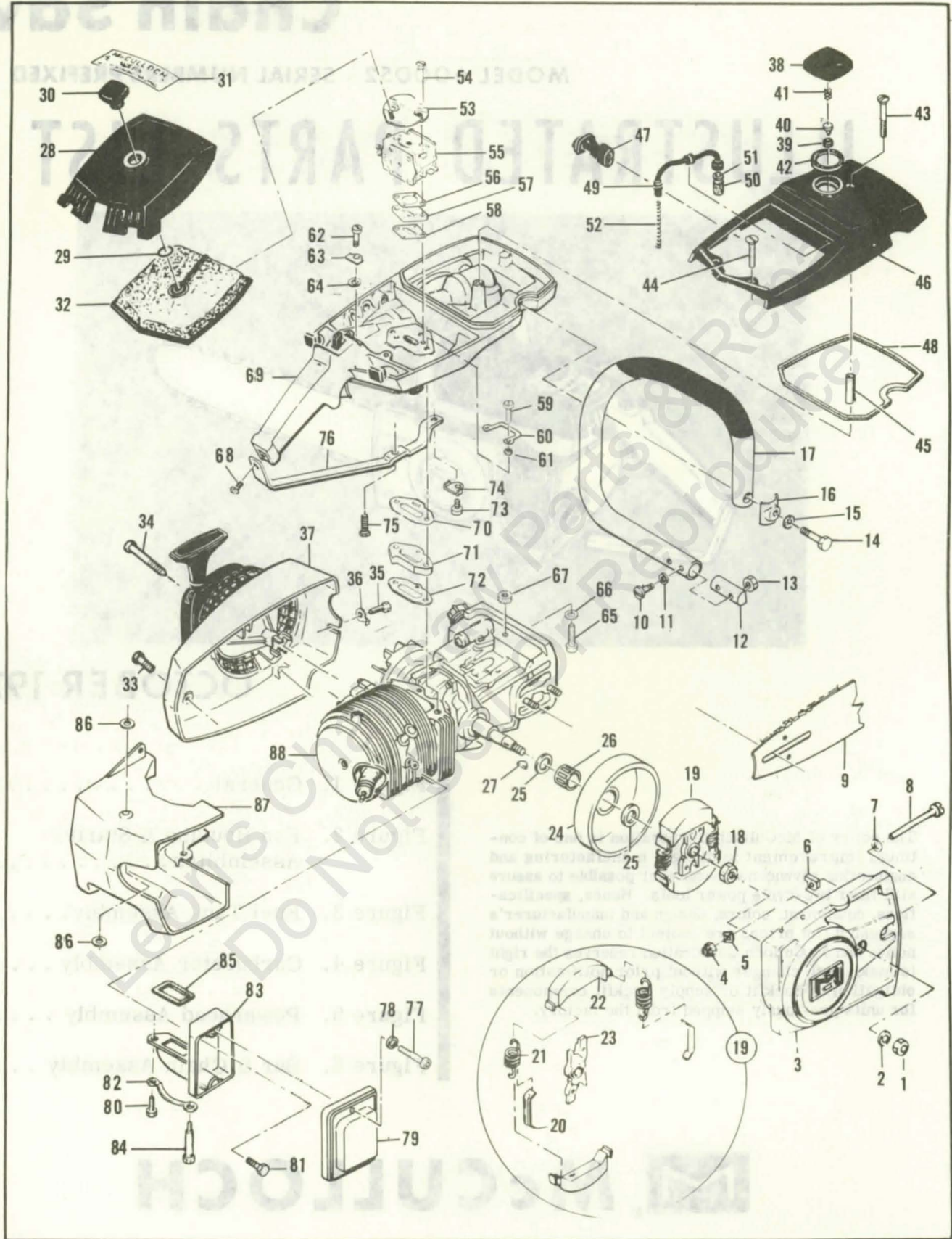

Figure 1. General

FIGURE 1. GENERAL

Item No.	Part Number	Description	Units Per Assy	Item No.	Part Number	Description	Units Per Assy
1	110454	Nut - Hex 5/16-24	2	46	84252	Cover - Fuel tank	1
2	100440	Washer - 5/16	2	47	84253	Boot - Carburetor	1
3	84530	Clutch Guard Assy	1	48	69345	Gasket - Cover	1
4	102067	. Nut - Hex 10-24	1	49	64848	Hose Assy - Fuel	1
5	110387	. Washer - Wavey	1	50	63932	. Filter - Fuel	1
6	61705	. Nut - Bar adjustment	1	51	100440	. Washer	1
7	110264	. Washer - #10	1	52	67944	Spring - Hose	1
8	102144	. Screw - Bar adjustment	1	53	83204	Bracket Assy	1
9		Bar & Chain Assy (See Figure 6)		54	103357	. Screw - Hex hd 10-24 x 2-1/4	2
10	102761	Screw - Hex hd 10-24 x 7/8	2	55		Carburetor Assy (See Figure 4)	
11	100352	Washer - #10	2	56	83059	Gasket - Carburetor	1
12	61678	Plug - Nut retainer	1	57	84078	Spacer - Carburetor	1
13	101326	Nut - Hex 10-24	2	58	84081	Gasket - Spacer	1
14	102130	Screw - Hex hd 1/4-20 x 1-1/2	1	59	110567	Screw - Hex hd 12-24 x 1-1/4	2
15	100153	Lockwasher - 1/4	1	60	68582	Lockplate	1
16	63484	Clamp - Frame	1	61	102115	Washer - #12	2
17	84269	Frame & Grip Assy	1	62	110568	Screw - Hex hd 12-24 x 1-1/8	1
18	110594	Nut - Hex 3/8-24	1	63	69516	Lockplate	1
19	67544	Clutch Assy	1	64	64856	Washer - Special	1
20	64583	. Retainer - Spring	2	65	102660	Screw - Skt hd 10-24 x 7/8	1
21	66384	. Spring - Clutch	2	66	100003	Washer - #10	1
22	67233	. Shoe - Clutch	2	67	69772	Spacer	1
23	62204C	. Rotor Assy	1	68	106078	Screw - Pan hd 10-24 x 7/16	1
24	65370	Kit - Sprocket & Drum	1	69		Fuel Tank Assy (See Figure 3)	
25	61692	. Shim	2	70	84082	Gasket - Fuel tank	1
26	110330	Bearing	1	71	84080	Insulator - Fuel tank	1
27	103879	Key - Woodruff	1	72	68594	Gasket - Insulator	1
28	68530	Cover Assy - Air cleaner	1	73	110566	Screw - Hex hd 12-24 x 5/8	1
29	110565	. Ring - Retainer	1	74	68508	Lockplate	1
30	68529	. Knob - Cover	1	75	110682	Screw - Hex hd 10-24 x 5/8	1
31	85014	Nameplate	1	76	85007	Brace - Handle	1
32	69922	Filter Assy - Air	1	77	101563	Screw - Skt hd 10-24 x 1-1/4	2
33	110684	Screw - Pan hd 10-24 x 3/8	1	78	110264	Washer - #10	2
34	62978	Screw - Special	3	79	83966	Cover - Muffler	1
35	102762	Screw - Hex hd 10-24 x 1/2	1	80	84776	Screw - Special	1
36	69890	Lockplate	1	81	110529	Screw - Hex hd 10-24 x 1/2	1
37		Fan Housing & Starter Assy (See Figure 2)		82	67922	Lockplate	1
38	68531	Cap Assy - Fuel	1	83	83106	Body & Duct Assy	1
39	68533	. Plug	1	84	68187	. Screw - Special	1
40	63041	. Valve	1	85	84007	Gasket - Spark arrester	1
41	63040	. Spring	1	86	68581	Insulator - Shroud	2
42	69767	. Gasket	1	87	67910	Shroud	1
43	110402	Screw - Oval hd 12-24 x 2-3/8	1	88		Powerhead Assy (See Figure 5)	
44	103579	Screw - Fl hd 10-24 x 1	2				
45	69686	Spacer	1				

FIGURE 1. GENERAL

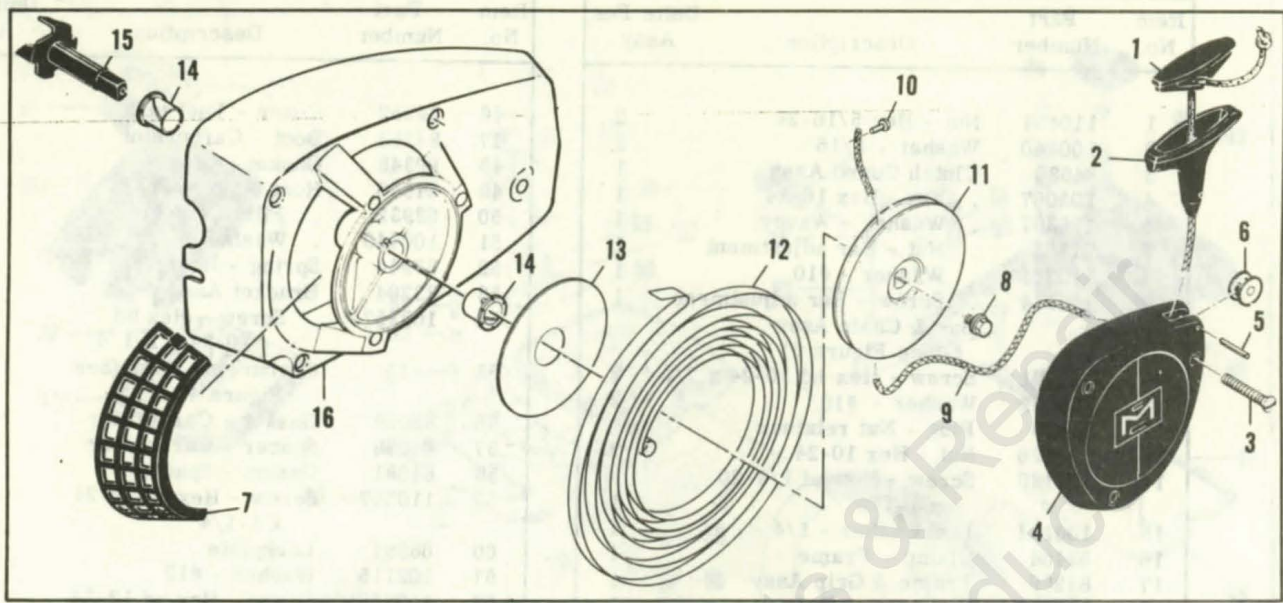

Figure 2. Fan Housing & Starter Assemblies

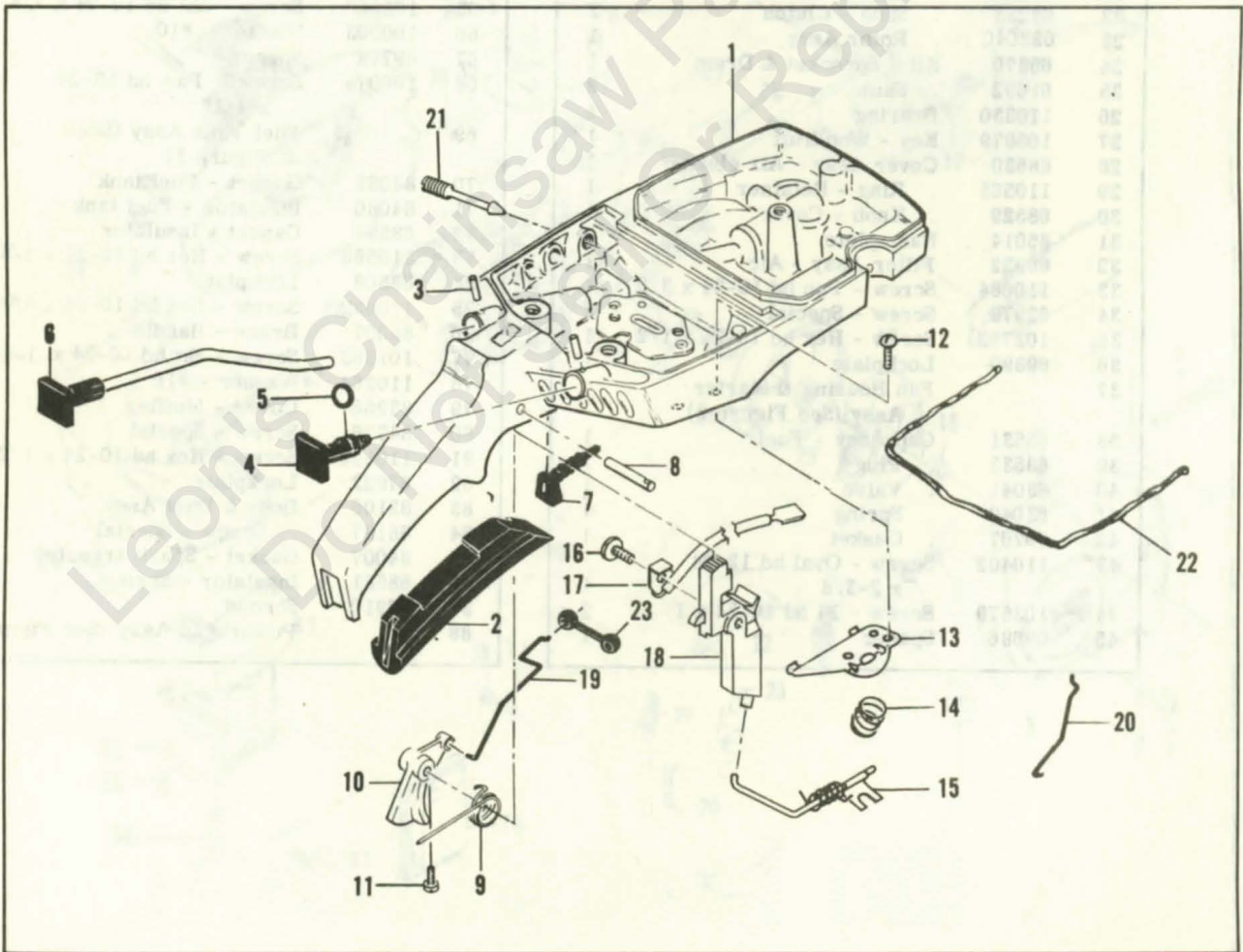

Figure 3. Fuel Tank Assembly

FIGURE 2. FAN HOUSING & STARTER ASSEMBLIES

Item No.	Part Number	Description	Units Per Assy
1	62191A	Insert - Starter handle	1
2	62190A	Handle - Starter	1
3	110646	Screw - Oval hd 8-32 x 1-1/8	3
4	84559	Cover Assy - Starter	1
5	110657	Pin - Roll	1
6	84051	Pulley - Rope	1
7	83598	Guard - Sawdust	3
8	110529	Screw - Hex hd 10-24 x 1/2	1

Item No.	Part Number	Description	Units Per Assy
9	69964	Rope - Starter	1
10	110470	Rivet - Rope	1
11	83597	Drum - Starter	1
12	83334	Spring - Rewind	1
13	83994	Shield - Spring	1
14	57535	Bushing - Shaft	2
15	83748	Shaft - Starter	1
16	83958	Housing - Fan	1

FIGURE 3. FUEL TANK ASSEMBLY

Item No.	Part Number	Description	Units Per Assy
1	84183	Fuel Tank Assy	1
2	64872	Grip - Handle	1
3	105673	Pin - Roll 3/32 x 9/16	2
4	69041	Button - Choke	1
5	101056	"O" Ring	1
6	64871	Button & Rod Assy	1
7	68522	Seal - Throttle rod	1
8	110378	Pin - Roll 3/16 x 15/16	1
9	65734	Spring - Throttle return	1
10	67224	Trigger	1
11	110537	Screw - Fil hd 8-36 x 1/2	1
12	105249	Screw - Rd hd 8-32 x 3/8 (SEMS) 2	2

Item No.	Part Number	Description	Units Per Assy
13	64721	Bracket - Lever Assy	1
14	69687	Spring - Valve	1
15	69811	Lever Assy - Compression release	1
16	110385	Screw - Pan hd 8-32 x 3/8	1
17	65873	Wire Assy - Stop switch	1
18	67209	Button - Control	1
19	68170	Rod - Throttle	1
20	69042	Rod - Choke	1
21	67271	Screw - Idle adjustment	1
22	*69564	Seal - Airbox	AR
23	69043	Snubber - Rod	1

*Furnished on a 12-1/2 inch strip containing 9 beads of sealant (enough for 9 replacements).

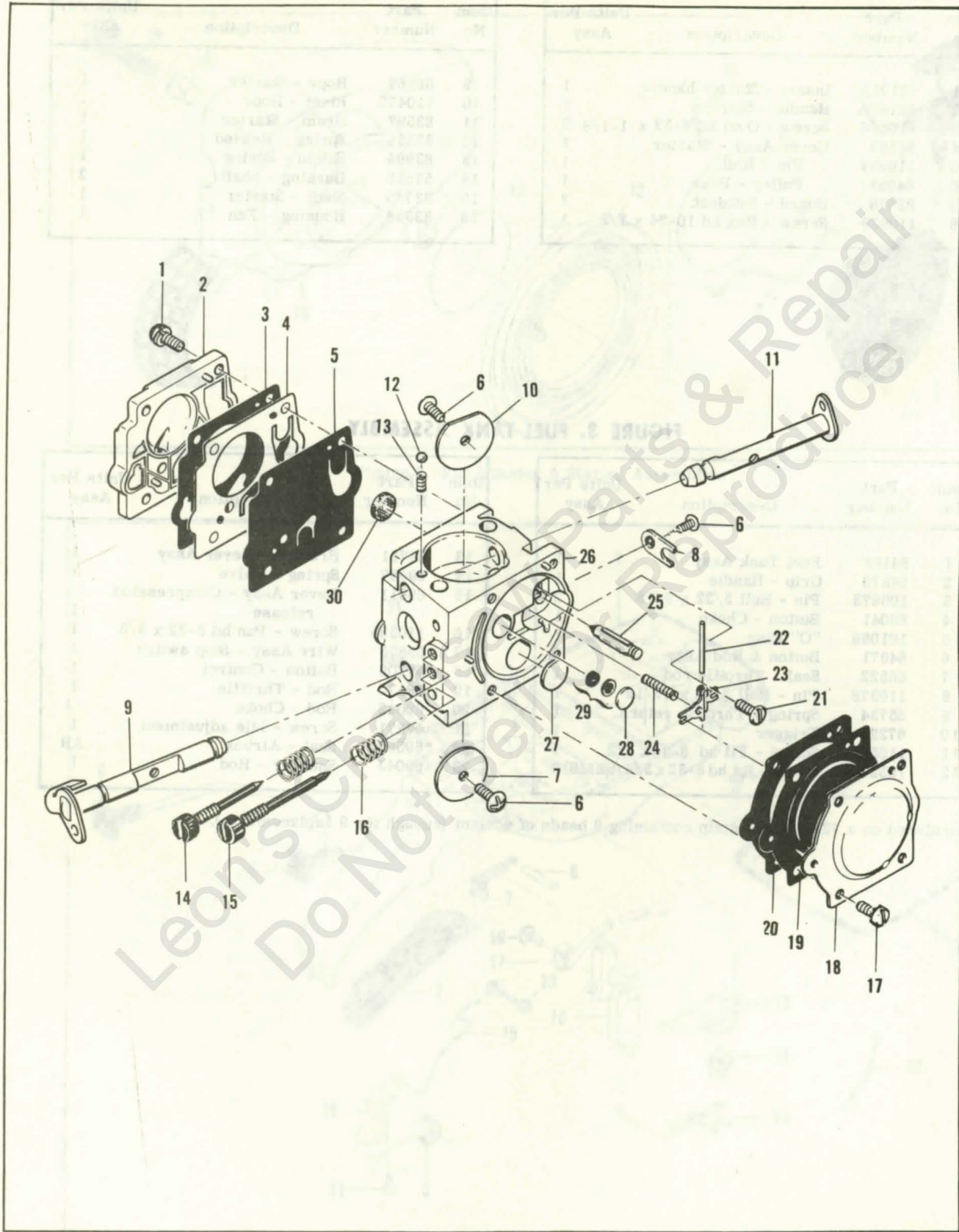

Figure 4. Carburetor Assembly

FIGURE 4. CARBURETOR ASSEMBLY

Item No.	Part Number	Description	Units Per Assy
	69942	Carburetor Assy	1
1	67501	. Screw - Pump cover	4
2	83760	. Cover - Pump	1
3	*67495	. Gasket - Cover	1
4	*67498	. Diaphragm - Check valve	1
5	*83114	. Diaphragm - Fuel pump	1
6	*47690	. Screw - Plate	3
7	83762	. Plate - Throttle	1
8	67489	. Clip - Shaft	1
9	67486	. Shaft Assy - Throttle	1
10	67490	. Plate - Choke	1
11	67488	. Shaft Assy - Choke	1
12	*100302	. Ball - Choke friction	1
13	*67504	. Spring - Choke	1
14	*68104	. Needle - High speed	1
15	*68105	. Needle - Idle	1

Item No.	Part Number	Description	Units Per Assy
16	*67502	. Spring - Needle	2
17	70798	. Screw - Diaphragm cover	4
18	83761	. Cover - Diaphragm	1
19	*67499	. Diaphragm - Metering	1
20	*67496	. Gasket - Diaphragm	1
21	*67500	. Screw - Lever pin	1
22	*67508	. Pin - Lever	1
23	*67509	. Lever - Metering	1
24	*67503	. Spring - Lever	1
25	*67491	. Valve - Needle	1
26	83759	. Body Assy - Carburetor	1
27	*71690	. Plug - 3/8	1
28	*69506	. Plug - 5/16	1
29	83758	. Kit - Valve & Seat Assy	1
30	*67507	. Screen - Fuel	1
	*67482	Gasket Set	
	83764	Repair Kit	

*Indicates parts included in Repair Kit, P/N 83764



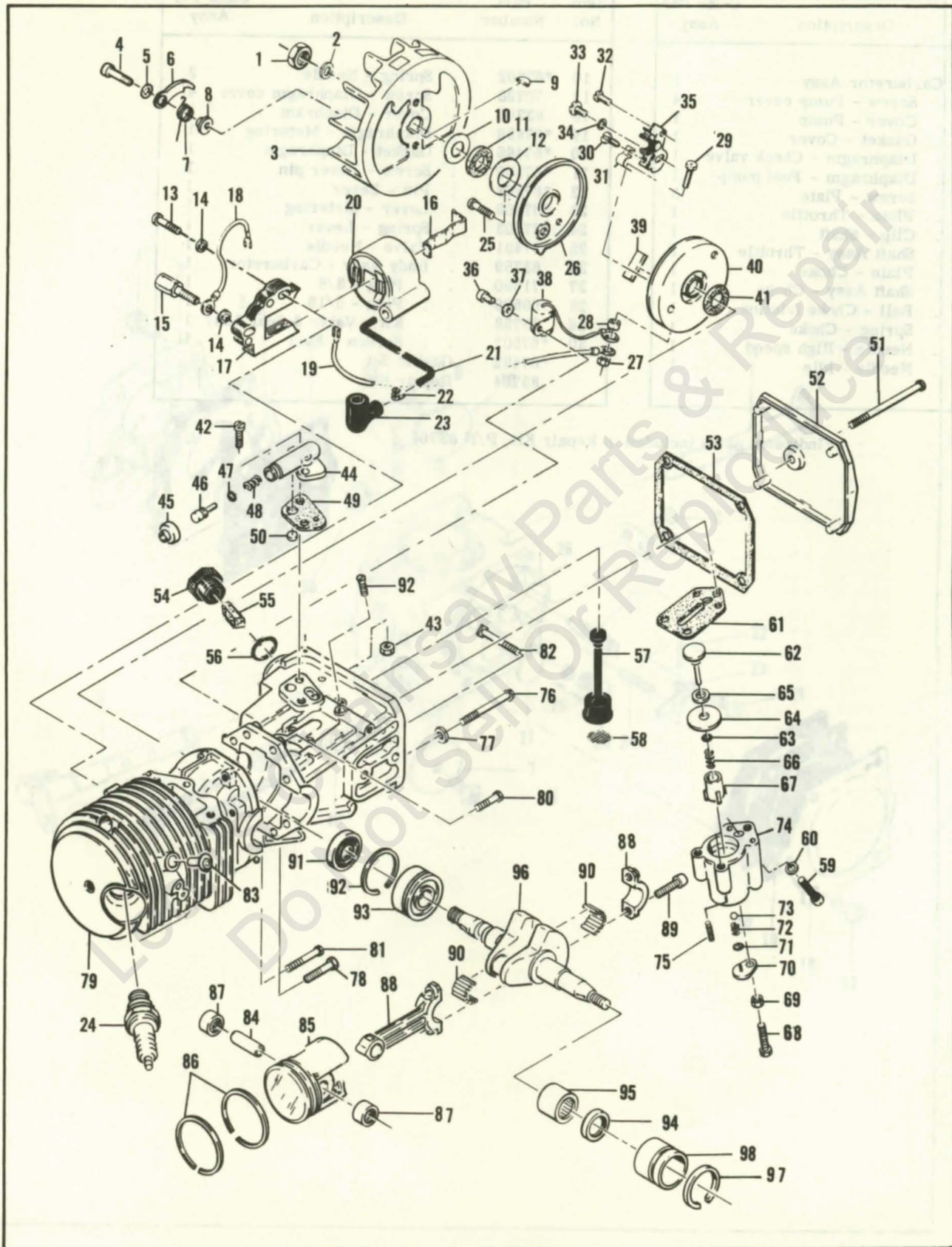

Figure 5. Powerhead Assembly

FIGURE 5. POWERHEAD ASSEMBLY

Item No.	Part Number	Description	Units Per Assy
1	101141	Nut - Hex 3/8-24	1
2	105999	Washer - 3/8	1
3	67845	Flywheel	1
4	102660	Screw - Skt hd 10-24 x 7/8	2
5	83241	Washer - Special	2
6	67546	Pawl - Starter	2
7	67545	Spring - Pawl	2
8	67547	Pivot - Pawl	2
9	103879	Key - Woodruff	1
10	67057	Washer - Thrust	1
11	67056	Seal - Breaker box Cover	1
12	67054	Washer - Thrust	1
13	110127	Screw - Hex hd 10-24 x 7/8 (SEMS)	1
14	100003	Washer - #10	2
15	83512	Stud - Special	1
16	51253	Retainer - Coil	1
17	68164	Lamination Assy	1
18	84686	Wire Assy - Ground	1
19	69344	Wire Assy - Primary	1
20	69798	Kit - Coil	1
21	69966	Wire Assy - Spark plug	1
22	62932	Connector	1
23	62926	Boot	1
24	63432	Spark Plug - AC CS 42 T	1
25	110349	Screw - Rd hd 8/32 x 3/4	1
26	62362	Cover - Breaker box	1
27	100298	Nut - Hex 6-32	1
28	62365	Spacer - Breaker	1
29	110346	Screw - Hex hd 6-32 x 3/4	1
30	110489	Screw - Pan hd 6-32 x 7/16 s/t	1
31	83126	Strap - Conduction	1
32	100934	Screw - Rd hd 8-32 x 3/8	1
33	110445	Screw - Truss hd 8-32 x 3/8	1
34	105976	Washer - #8	1
35	66231	Breaker Assy	1
36	103672	Screw - Fil hd 8-32 x 1/2 (SEMS)	1
37	100080	Washer - #8	1
38	67960	Condenser	1
39	54184	Wiper - Cam	1
40	84329	Box - Breaker	1
41	67051	Seal - Breaker box	1
42	110623	Screw - Fil hd 8-32 x 1/2	2
43	100955	Nut - Hex 8-32	1
44	84156	Housing - Pump	1
45	62262	Cap - Housing	1
46	62266	Plunger - Pump	1
47	101056	"O" Ring	1
48	66687	Spring - Pump	1
49	62230	Gasket - Pump	1

Item No.	Part Number	Description	Units Per Assy
50	62909	Valve - Pump	1
51	110291	Screw - Pan hd 10-24 x 2-5/8	1
52	63072	Cover - Oil tank	1
53	62116	Gasket - Cover	1
54	68809	Cap - Oil tank	1
55	84953	Plug - Cap	1
56	101148	"O" Ring	1
57	62123B	Hose Assy - Oil	1
58	51506	Screen - Hose	1
59	102660	Screw - Skt hd 10-24 x 7/8	1
60	24236	Washer - Special	1
61	83790	Gasket - Pulse pump	1
	83786	Pump Assy - Pulse	1
62	60260A	Piston Assy - Pump	1
63	104001	"O" Ring	1
64	60263	Ring - Piston	1
65	60937	Washer - Teflon	1
66	60259	Spring - Piston	1
67	62227	Sleeve - Adjustment	1
68	110386	Screw - Hex hd 8-32 x 1	1
69	100251	Nut - Hex 8-32	1
70	62407	Cover - Outlet valve	1
71	106104	"O" Ring	1
72	62885A	Spring - Outlet valve	1
73	102809	Ball	1
74	83787	Body Assy - Pump	1
75	110643	Screw - Set	1
76	62105	Screw Assy - Sealing	4
77	62842	Washer - Sealing	4
78	110288	Screw Assy - Hex 8-32 x 3/4	1
79	84105	Crankcase Assy	1
80	110288	Screw Assy - Hex 8-32 x 3/4	2
81	110618	Screw Assy - Hex 8-32 x 1-3/8	1
82	62065	Bolt - Bar mounting	2
83	84221	Valve - DSP	1
84	69020	Pin - Piston	1
85	69030	Piston Assy	1
86	63290	Ring Set - Piston	1
87	110590	Bearing - Needle	2
88	83060	Connecting Rod Assy	1
89	61627A	Screw - Skt hd special	2
90	63225	Roller - Needle (set of 20)	1
91	61618	Seal - Oil	1
92	63464	Ring - Snap	1
93	63429B	Bearing - Ball	1
94	110260	Seal - Oil	1
95	104357	Bearing - Needle	1
96	63336	Crankshaft	1
97	63699	Ring - Bearing insert	1
98	63701	Insert - Bearing	1

FIGURE 2. POWERHEAD ASSEMBLY

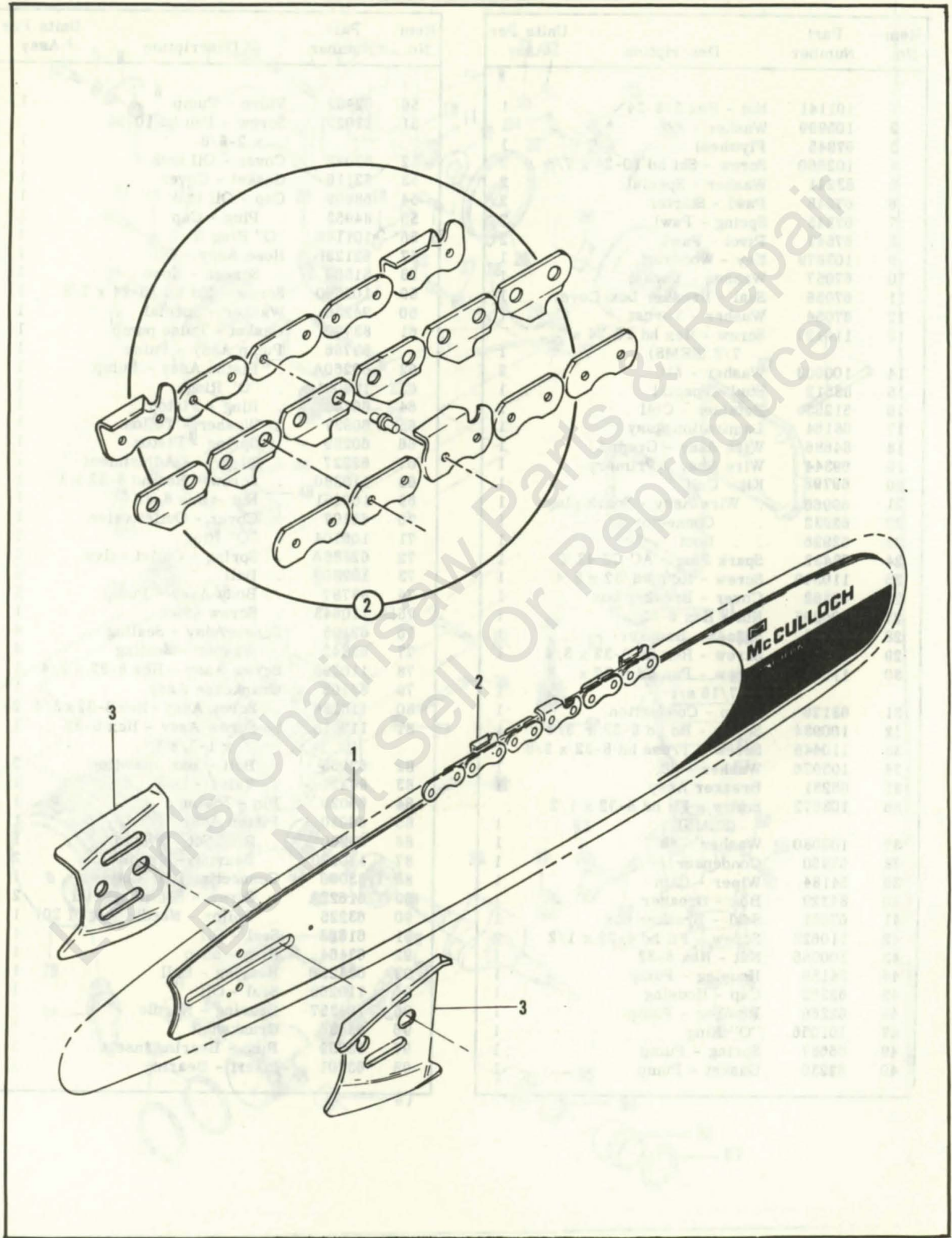

Figure 6. Bar & Chain Assembly

FIGURE 6. BAR AND CHAIN ASSEMBLIES

Item No.	Part Number	Description	Units Per Assy
1	63541	Bar	
2	62556M	Chain Assy	

Item No.	Part Number	Description	Units Per Assy
	64330	Set - Bar Plate	1
3	64325	Plate - Bar	2

SERVICE SPECIFICATIONS

Spark Plug Gap -----	0.025 in.
Lamination Gap -----	0.010 to 0.015 in.
Breaker Point Gap -----	0.018 in.
Carburetor Adjustment	
Idle Needle - Preliminary adjustment 1 turn open.	
	Adjust for smooth idle and acceleration.
Main Needle - Preliminary adjustment 1 turn open.	
	Adjust for maximum power under load.
Torque Values	
Flywheel Nut -----	240 to 300 inch-pounds.
Clutch Nut -----	160 to 170 inch-pounds.
Connecting Rod Screws -----	65 to 70 inch-pounds.

ACCESSORIES

Part Number	Description
83434	Manual - Owner's
62827	Wrench - Screwdriver
63746	Scrench
63341A	Kit - Spike
69058	Kit - Wrap-around frame

Part Number	Description
84922	Kit - Baffle
65712	Guide - Timing
63097	Spark Plug - AC CS45T
65778	Spark Plug - AC CS41T
69191	Kit - Pressure adaptor
84453	Kit - Piston tool



McCULLOCH



● MANUFACTURING ●

SALES ●

● SERVICE ●

McCULLOCH CORPORATION

6101 WEST CENTURY BLVD., LOS ANGELES, CALIFORNIA 90045
INTERNATIONAL DIVISIONS:

LOS ANGELES, CALIF., P. O. BOX 45466
HONG KONG, B. C. C.: G. P. O. BOX 879

McCULLOCH OF CANADA LTD.

6338 VISCOUNT ROAD, MALTON, ONTARIO, CANADA

McCULLOCH OF EUROPE, N. V.

ANTOON SPINOYSTRAAT, 5, B-2800 MECHELEN, BELGIUM

McCULLOCH OF AUSTRALIA PTY., LTD.

P.O. BOX 223, SEVEN HILLS, N.S.W. 2147, AUSTRALIA

Leon's Chairm...
Do Not Sell...
Produce

Part Number	Description
81123	Kil - Wrench
8019	Kil - Wrench
8018	Kil - Wrench
8017	Kil - Wrench
8016	Kil - Wrench
8015	Kil - Wrench
8014	Kil - Wrench
8013	Kil - Wrench
8012	Kil - Wrench
8011	Kil - Wrench
8010	Kil - Wrench
8009	Kil - Wrench
8008	Kil - Wrench
8007	Kil - Wrench
8006	Kil - Wrench
8005	Kil - Wrench
8004	Kil - Wrench
8003	Kil - Wrench
8002	Kil - Wrench
8001	Kil - Wrench

Part Number	Description
8008	Kil - Wrench
8007	Kil - Wrench
8006	Kil - Wrench
8005	Kil - Wrench
8004	Kil - Wrench
8003	Kil - Wrench
8002	Kil - Wrench
8001	Kil - Wrench