

MASTER ILLUSTRATED PARTS LIST

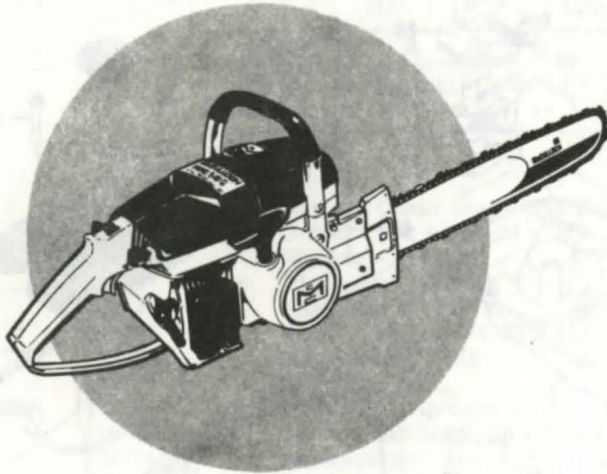

MAC 5-10G AUTOMATIC Chain Saw

JANUARY 1972

For cancelled and discarded
Parts Lists see page 5.

The policy of McCulloch Corporation is one of continual improvement in design, manufacturing and engineering advancement wherever possible to assure still finer two-cycle power tools. Hence, specifications, equipment, colors, design and manufacturer's suggested list prices are subject to change without notice and McCulloch Corporation reserves the right to make such changes without prior notification or obligation to backfit or supply backfit components for units previously shipped from the factory.

This Master Illustrated Parts List gives the name, number and interchangeability between engines, of service and replacement parts which were used on or are presently available for all MAC 5-10G chain saws manufactured to date.

CONTENTS

	Page
Figure 1. General	2
Figure 2. Clutch and Starter Assembly . . .	6
Figure 3. Fuel Tank Assembly	8
Figure 4. Carburetor Assembly	10
Figure 5. Carburetor Assembly	12
Figure 6. Transmission Assembly	14
Figure 7. Powerhead Assembly	16

Information about the List and how to use it will be found on the back cover.
Read the information before you start to use the List.

 **McCULLOCH**

MAC 5-10G AUTOMATIC

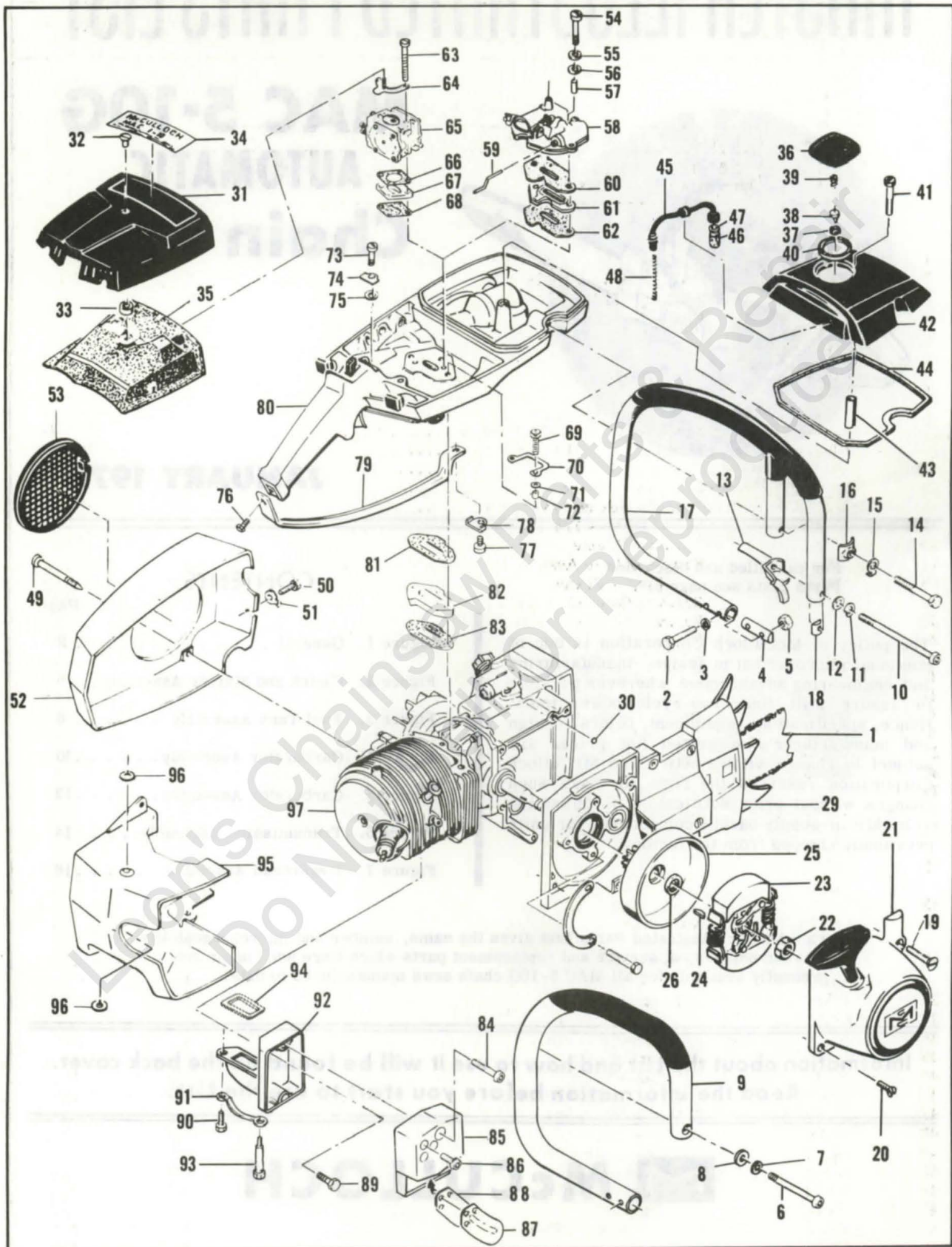

Figure 1. General

Figure 1. General

Item No.	Part Number	Description	Units Per Assy	Usable on Code		
MAC 5-10G USABLE ON CODE						
		Letter	A	B	C	D
		Serial Numbers	Without Prefix	Prefix 1-	Prefix 10-	Prefix 11-
1		Bar and Chain Assys (See Figure 6)				All
2	102761	Screw - Hex hd 10-24 x 7/8				All
3	100352	Washer - #10				All
4	61678	Plug - Nut retainer				All
5	101326	Nut - Hex 10-24				All
6	105187	Screw - Skt hd 1/4-20 x 1-1/8				A
7	105043	Lockwasher - 1/4				A
8	100004	Washer - 1/4				A
9	67372	Frame & Grip Assy				A
10	110448	Screw - Skt hd 10-24 x 3-1/4				B,C,D
11	103174	Lockwasher - #10				B,C,D
12	100003	Washer - #10				B,C,D
13	68503	Bracket - Frame				B,C,D
14	102130	Screw - Hex hd 1/4-20 x 1-1/2				B,C,D
15	100153	Lockwasher - 1/4				B,C,D
16	63484	Clamp - Frame				B,C,D
17	67479	Frame & Grip Assy				B,C,D
18	62271	Plug - Frame				B,C,D
19	104139	Screw - Oval hd 10-24 x 1-1/2				A
20	110403	Screw - Oval hd 8-32 x 5/8				All
21		Starter Assy (See Figure 2)				All
22	103746	Nut - Hex 3/8-24				All
23		Clutch Assy (See Figure 2)				All
24	103879	Key - Woodruff				All
25	63493	Drum, Gear & Seal Assy				All
26	63476	Seal				All
27	102765	Screw - Hex hd 10-24 x 1-3/4				All
28	68509	Lockplate				All
29		Transmission Assy (See Figure 6)				All
30	106104	"O" Ring				All
31	65750	Cover Assy - Air cleaner				A,B
	66597	Cover Assy - Air cleaner				C,D
32	65720	Nut - Cover				A,B
	66290	Nut - Cover				C,D
33	66665	Spacer - Nut				C,D
34	64749	Nameplate				A,B
	67926	Nameplate				C,D
35	68521	Filter - Air				A,B
	68520	Filter - Air				C,D
36	68531	Cap Assy - Fuel				All
37	68533	Plug				All
38	63041	Valve				All
39	63040	Spring				All
40	69767	Gasket				All
41	110402	Screw - Oval hd 12-24 x 2-3/8				All
42	63288	Cover - Fuel tank				All
43	69686	Spacer - Cover				All
44	69345	Gasket - Cover				All
45	64848	Hose Assy - Fuel				All
46	63932	Filter - Fuel				All
47	100440	Washer				All
48	67944	Spring - Hose stiffener				All
49	62978	Screw - Special				All

Figure 1. General (Continued)

Item No.	Part Number	Description	Units Per Assy	Usable on Code
50	102762	Screw - Hex hd 10-24 x 1/2	1	All
51	69890	Lockplate	1	All
52	83521	Kit - Fan housing	1	All
53	55615	Guard - Flywheel	1	All
54	103356	Screw - Hex hd 10-24 x 2-1/8	2	A,B
55	64856	Washer - Special	2	A,B
56	68203	Washer - Insulator	2	A,B
57	65726	Sleeve - Insulator	2	A,B
58		Carburetor Assy (See Figure 4)		A,B
59	65758	Rod - Primer	1	A,B
60	65739	Gasket - Carburetor	1	A,B
61	66232	Insulator - Carburetor	1	A,B
62	65739	Gasket - Insulator	1	A,B
63	103356	Screw - Hex hd 10-24 x 2-1/8	2	C,D
64	66681	Bracket Assy	1	C,D
65		Carburetor Assy (See Figure 5)		C,D
66	68132	Gasket - Carburetor	1	C,D
67	84078	Spacer - Carburetor	1	C,D
68	68131	Gasket - Spacer	1	C,D
69	110553	Screw - Hex hd 10-24 x 1-3/8	2	C,D
70	68582	Lockplate	1	C,D
71	100003	Washer - #10	2	C,D
72	66189	Sleeve	2	C,D
73	110516	Screw - Hex hd 10-24 x 1-1/8	1	All
74	63475	Lockplate	1	All
75	64856	Washer - Special	1	All
76	110353	Screw - Oval hd 10-24 x 3/8	1	All
77	102388	Screw - Hex hd 10-24 x 5/8	1	All
78	69890	Lockplate	1	All
79	85007	Brace - Handle	1	All
80		Fuel Tank Assy (See Figure 3)		All
81	84082	Gasket - Fuel tank	1	All
82	66661	Insulator - Fuel tank	1	All
83	68129	Gasket - Insulator	1	All
	68191	Kit - Spark arrester	1	All
84	110473	Screw - Skt hd 10-24 x 1-5/8	2	All
85	65532	Cover & Valve Assy	1	All
86	110472	Screw - Skt hd 8-32 x 5/16	3	All
87	84780	Stop - Reed	1	All
88	84779	Valve - Reed	1	All
89	110529	Screw - Hex hd 10-24 x 1/2	1	All
90	110506	Screw - Hex hd 10-24 x 5/8	1	All
91	67922	Lockplate	1	All
92	83106	Kit - Body & Duct	1	All
93	68187	Screw - Special	1	All
94	68149	Gasket - Spark arrester	1	All
95	67910	Shroud	1	All
96	68581	Insulator - Shroud	2	All
97		Powerhead Assy (See Figure 7)		All

Figure 2. SERVICE SPECIFICATIONS

Spark Plug Gap -----	0.025 in.
Lamination Gap -----	0.010 to 0.015 in.
Breaker Point Gap -----	0.018 in.
Torque Values	
Flywheel Nut -----	240 to 300 inch-pounds.
Clutch Nut -----	160 to 170 inch-pounds.
Connecting Rod Screws -----	65 to 70 inch-pounds.

Master Illustrated Parts List, P/N 86347, supersedes and cancels all previous lists issued for the MAC 5-10G saw. Discard the following lists:

IPL 65678 and

Parts list sheet 66114 covering saws having serial numbers without prefix.

Parts list sheet 66554 covering saws having serial numbers prefixed 1-.

IPL 67466 covering saws having serial numbers prefixed 10-.

Addendum 69011 covering saws having serial numbers prefixed 11-.

Leon's Chainsaw Parts & Repair
Do Not Reproduce

MAC 5-10G
AUTOMATIC

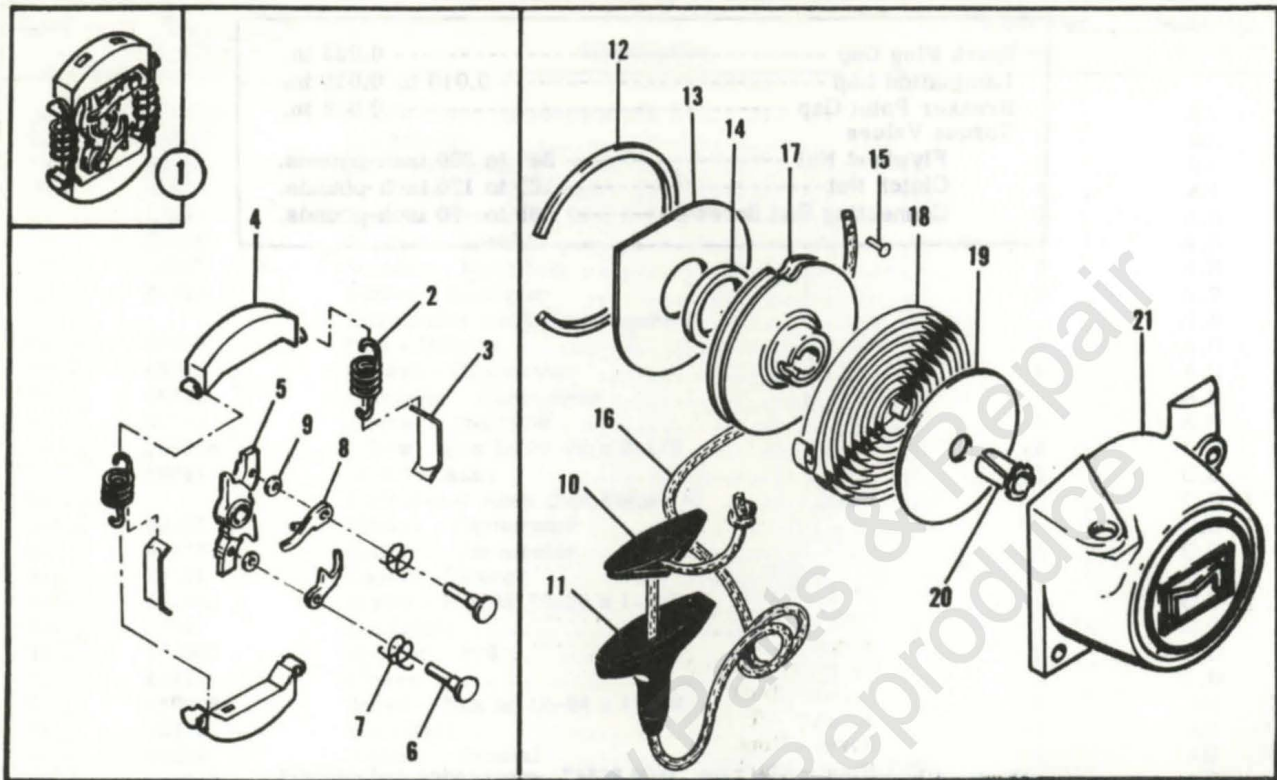

Figure 2. Clutch and Starter Assembly

Figure 2. Clutch and Starter Assemblies

Item No.	Part Number	Description	Units Per Assy	Usable on Code										
MAC 5-10G USABLE ON CODE														
<table border="1" style="margin-left: auto; margin-right: auto;"> <thead> <tr> <th>Letter</th> <th>A</th> <th>B</th> <th>C</th> <th>D</th> </tr> </thead> <tbody> <tr> <td>Serial Numbers</td> <td>Without Prefix</td> <td>Prefix 1-</td> <td>Prefix 10-</td> <td>Prefix 11-</td> </tr> </tbody> </table>					Letter	A	B	C	D	Serial Numbers	Without Prefix	Prefix 1-	Prefix 10-	Prefix 11-
Letter	A	B	C	D										
Serial Numbers	Without Prefix	Prefix 1-	Prefix 10-	Prefix 11-										
1	67148	Clutch Assy	1	All										
2	66384	. Spring - Clutch	2	All										
3	64583	. Retainer - Spring	2	All										
4	67233	. Shoe - Clutch	2	All										
5	67149	. Rotor Assy	1	All										
6	67112	. Rivet	2	All										
7	68837	. Spring - Pawl	2	All										
8	64857	. Pawl	2	All										
9	65473	. Washer	2	All										
	83694	Starter Assy	1	All										
10	62191A	. Insert - Handle	1	All										
11	62190A	. Handle	1	All										
12	67205	. Retainer - Shield	1	All										
13	63985	. Shield - Dust	1	All										
14	63986	. Washer - Thrust	1	All										
15	110470	. Rivet - Rope	1	All										
16	69964	. Rope - Starter	1	All										
17	83651	. Drum - Starter	1	All										
18	68626	. Spring - Rewind	1	All										
19	63987	. Shield - Spring	1	All										
20	61635A	. Bushing - Nyliner	1	All										
21	67059	. Housing - Starter	1	All										

Leon's Chassis & Parts Repair
Do Not Sell or Reproduce

MAC 5-10G
AUTOMATIC

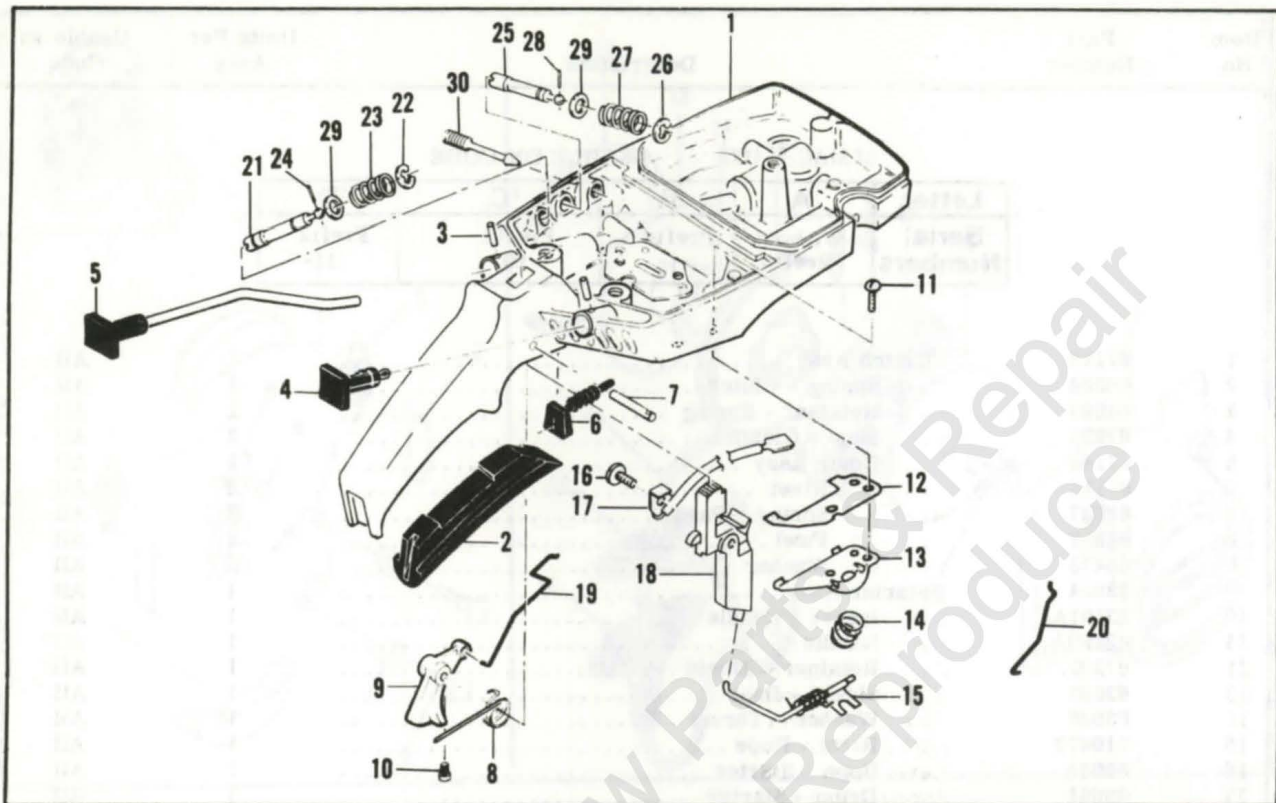

Figure 3. Fuel Tank Assembly

Figure 3. Fuel Tank Assembly

Item No.	Part Number	Description	Units Per Assy	Usable On Code										
		MAC 5-10G		USABLE ON CODE										
		<table border="1"> <thead> <tr> <th>Letter</th> <th>A</th> <th>B</th> <th>C</th> <th>D</th> </tr> </thead> <tbody> <tr> <td>Serial Numbers</td> <td>Without Prefix</td> <td>Prefix 1-</td> <td>Prefix 10-</td> <td>Prefix 11-</td> </tr> </tbody> </table>	Letter	A	B	C	D	Serial Numbers	Without Prefix	Prefix 1-	Prefix 10-	Prefix 11-		
Letter	A	B	C	D										
Serial Numbers	Without Prefix	Prefix 1-	Prefix 10-	Prefix 11-										
1	66649	Fuel Tank Assy	1	A,B										
	84183	Fuel Tank Assy	1	C,D										
2	64872	Grip - Handle	1	All										
3	105673	Pin - Roll 3/32 x 9/16	2	All										
4	66194	Button - Primer	1	A,B										
	68517	Button - Choke	1	C,D										
5	64871	Button & Rod Assy - Oiler	1	All										
6	67989	Seal - Throttle rod	1	All										
7	110378	Pin - Roll 3/16 x 15/16	1	All										
8	65734	Spring - Throttle return	1	All										
9	67224	Trigger	1	All										
10	110537	Screw - Fil hd 8-36 x 1/2	1	C,D										
11	105249	Screw - Rd hd 8-32 x 3/8 (SEMS)	2	All										
12	64621	Shield - Bracket	1	All										
13	64721	Bracket - Lever	1	All										
14	69687	Spring - Valve	1	All										
15	69811	Lever Assy - DSP	1	All										
16	110469	Screw - Pan hd 8-32 x 5/16 s/t	1	All										
17	65873	Wire Assy - Stop switch	1	All										
18	67210	Button Assy - Control	1	All										
19	66156	Rod - Throttle	1	A,B										
	68170	Rod - Throttle	1	C,D										
20	67355	Rod - Choke	1	C,D										
21	68102	Extension Assy - High speed needle	1	C,D										
22	110512	. Ring - Retaining	1	C,D										
23	67363	. Spring	1	C,D										
24	110509	. Pin - Groove	1	C,D										
25	68101	Extension Assy - Idle needle	1	C,D										
26	110512	. Ring - Retaining	1	C,D										
27	67363	. Spring	1	C,D										
28	110509	. Pin - Groove	1	C,D										
29	67292	Washer - Special	2	C,D										
30	67271	Screw - Idle adjustment	1	C,D										

MAC 5-10G
AUTOMATIC

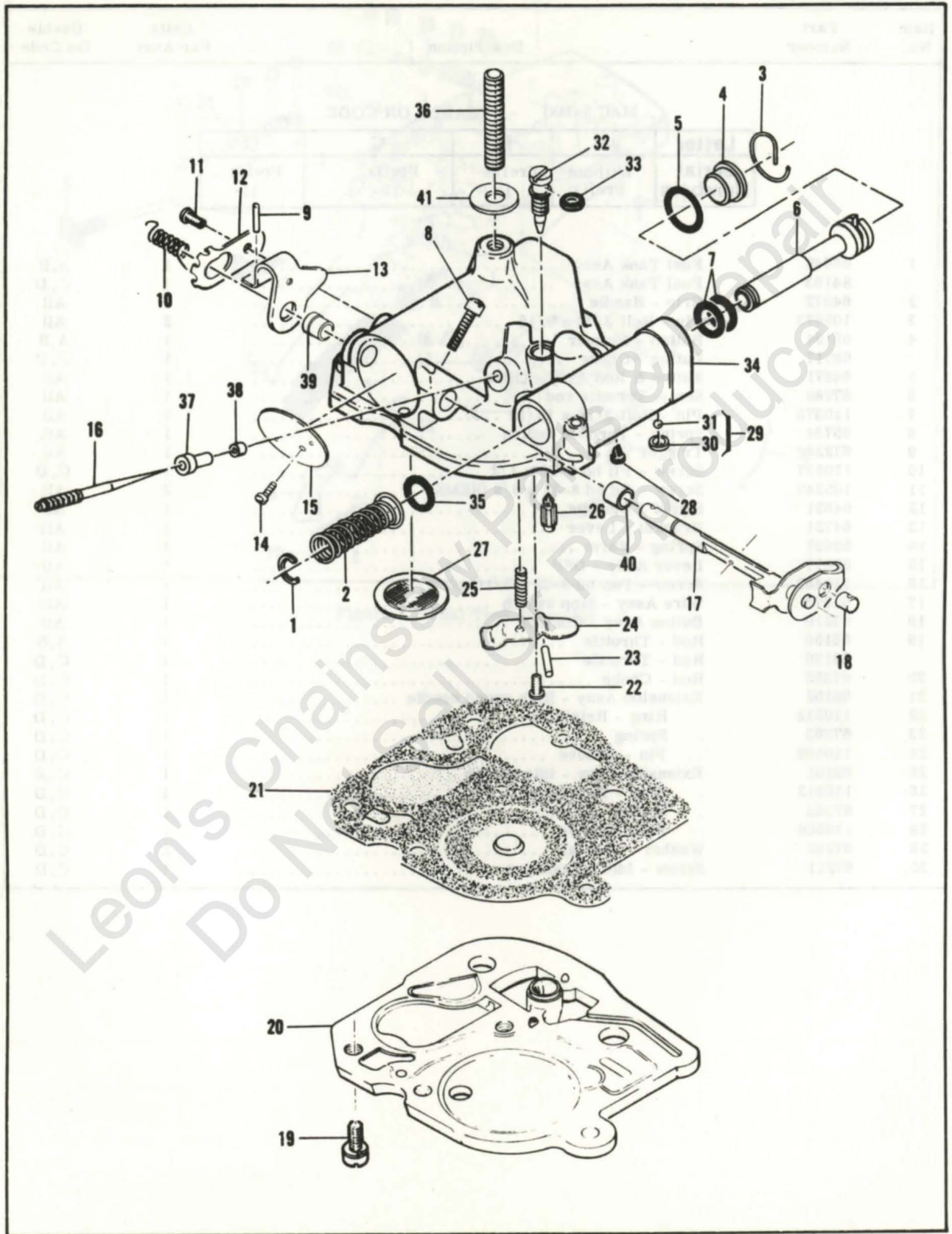

Figure 4. Carburetor Assembly

Figure 4. Fuel Tank Assembly

Item No.	Part Number	Description	Units Per Assy	Usable On Code		
		MAC 5-10G		USABLE ON CODE		
		Letter	A	B	C	D
		Serial Numbers	Without Prefix	Prefix 1-	Prefix 10-	Prefix 11-
1	66511	Carburetor Assy (McCulloch Double Needle)	1			A,B
2	101289	Ring - Retaining	1			A,B
3	65859	Spring - Plunger	1			A,B
4	65677	Retainer - Plug	1			A,B
5	65617	Plug - Primer	1			A,B
6	105617	"O" Ring	1			A,B
7	66552	Plunger - Primer	1			A,B
8	66551	"O" Ring	2			A,B
9	110483	Screw - Long locking	1			A,B
10	104245	Pin - Roll .062 x 1/2	1			A,B
11	62939A	Spring - Idle governor	1			A,B
12	103934	Screw - Rd hd 6-32 x 1/4 (SEMS)	1			A,B
13	62938	Clip - Throttle shaft	1			A,B
14	62343A	Lever - Throttle	1			A,B
15	104814	Screw - Pan hd 4-40 x 1/4 (SEMS)	1			A,B
16	62290A	Plate - Throttle	1			A,B
17	65431	Needle - Metering	1			A,B
18	62291A	Shaft Assy - Throttle	1			A,B
19	62975	Swivel - Needle	1			A,B
20	110397	Screw - Pan hd 8-32 x 7/16 (SEMS)	4			A,B
21	66507	Plate - Carburetor base	1			A,B
22	65608	Diaphragm Assy - Pump	1			A,B
23	104728	Screw - Bind hd 6-32 x 1/4	1			A,B
24	110337	Pin - Inlet lever	1			A,B
25	62310	Lever - Inlet	1			A,B
26	62923A	Spring - Inlet lever	1			A,B
27	63038	Valve - Inlet needle	1			A,B
28	55690B	Seal - Capillary	1			A,B
29	63041	Valve - Primer	1			A,B
30	65868	Set - Ball and seat	1			A,B
31	66153	Seat	1			A,B
32	61151	Ball	1			A,B
33	65445	Needle - Main fuel	1			A,B
34	104001	"O" Ring	1			A,B
35	66512	Body Assy - Carburetor	1			A,B
36	59796	"O" Ring	1			A,B
37	65724	Stud - Carburetor	1			A,B
38	66158	Orifice - Air	1			A,B
39	66569	Orifice - Fuel	1			A,B
40	62288A	Bushing - Throttle shaft	1			A,B
41	62368	Bushing - Throttle shaft	1			A,B
42	67062	Seal - Carburetor stud	1			A,B

MCCULLOCH DOUBLE NEEDLE CARBURETOR ADJUSTMENT

1. Turn Lo Speed screw counterclockwise until it no longer touches stop and butterfly can be completely closed.
2. Hold finger against closed butterfly and turn Lo Mix needle clockwise until butterfly starts to open. Turn the needle counterclockwise two and one half turns.
3. Hold finger against closed butterfly and turn Lo Speed screw clockwise until butterfly starts to open. Turn the screw clockwise one half turn more.
4. Turn Hi Mix needle clockwise until resistance is felt, then turn the needle counterclockwise two full turns.
5. Turn the Lo Mix needle to obtain smooth rapid acceleration every time without faltering. Check for smooth idle for all positions of the saw and readjust the Lo Mix needle if necessary.
6. Adjust Hi Mix needle for maximum power under load. Turn the needle in for leaner and out for richer mixture. Do not adjust the needle for leaner mixture than necessary to obtain smooth, even running under a cutting load.

MAC 5-10G
AUTOMATIC

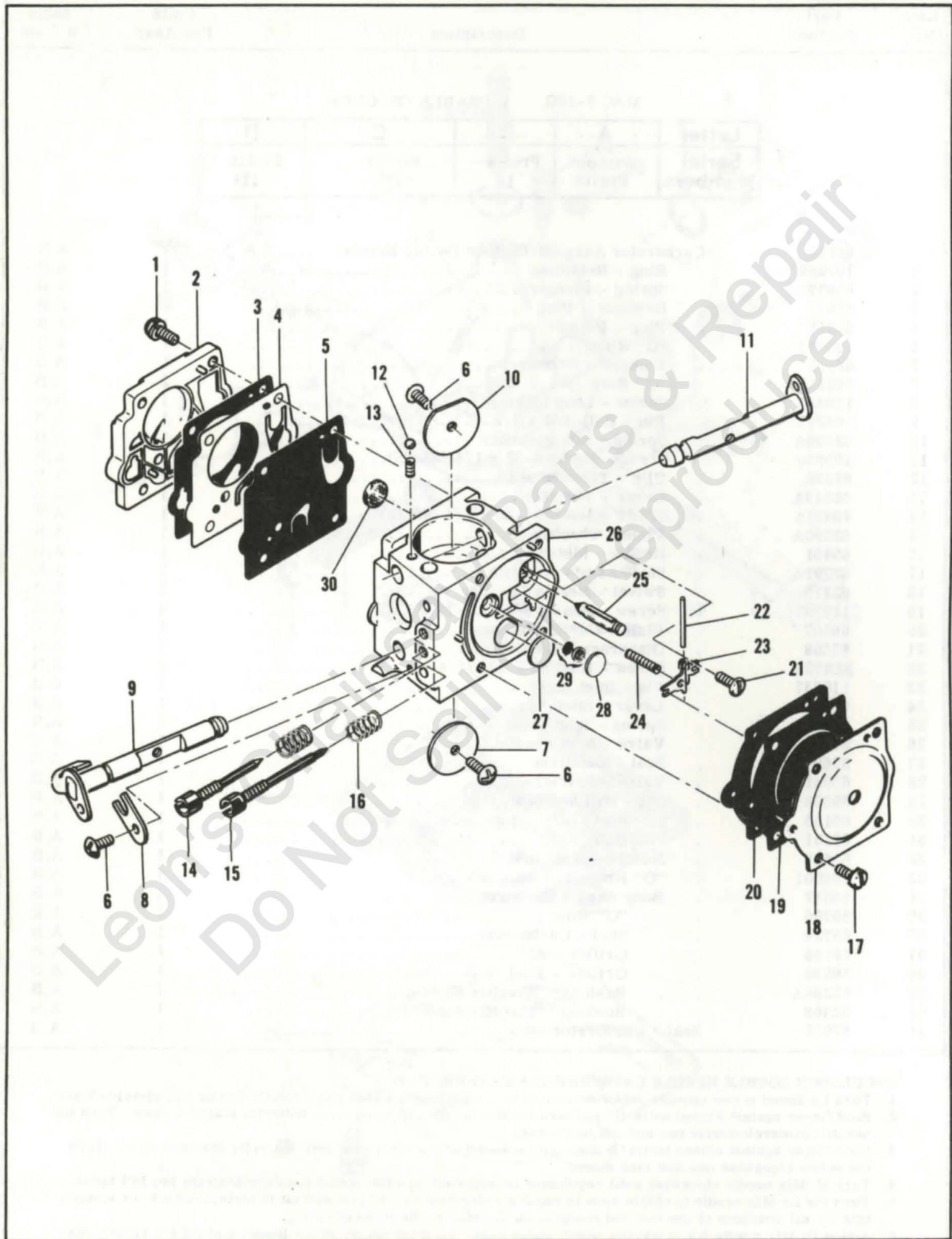

Figure 5. Carburetor Assembly

Figure 5. Carburetor Assembly

Item No.	Part Number	Description	Units Per Assy	Usable On Code										
MAC 5-10G USABLE ON CODE														
<table border="1" style="width: 100%; border-collapse: collapse;"> <thead> <tr> <th style="width: 20%;">Letter</th> <th style="width: 20%;">A</th> <th style="width: 20%;">B</th> <th style="width: 20%;">C</th> <th style="width: 20%;">D</th> </tr> </thead> <tbody> <tr> <td>Serial Numbers</td> <td>Without Prefix</td> <td>Prefix 1-</td> <td>Prefix 10-</td> <td>Prefix 11-</td> </tr> </tbody> </table>					Letter	A	B	C	D	Serial Numbers	Without Prefix	Prefix 1-	Prefix 10-	Prefix 11-
Letter	A	B	C	D										
Serial Numbers	Without Prefix	Prefix 1-	Prefix 10-	Prefix 11-										
	67379	Carburetor Assy (McCulloch SDC-2)	1	C, D										
1	67501	. Screw - Pump cover	4	C, D										
2	83760	. Cover - Pump	1	C, D										
3	*67495	. Gasket - Cover	1	C, D										
4	*67498	. Diaphragm - Check valve	1	C, D										
5	*83114	. Diaphragm - Fuel pump	1	C, D										
6	*47690	. Screw - Plate	3	C, D										
7	67487	. Plate - Throttle	1	C, D										
8	67489	. Clip - Shaft	1	C, D										
9	67486	. Shaft Assy - Throttle	1	C, D										
10	67490	. Plate - Choke	1	C, D										
11	67488	. Shaft Assy - Choke	1	C, D										
12	*100302	. Ball - Choke friction	1	C, D										
13	*67504	. Spring - Choke	1	C, D										
14	*67506	. Needle - High speed	1	C, D										
15	*67505	. Needle - Idle	1	C, D										
16	*67502	. Spring - Needle	2	C, D										
17	70798	. Screw - Diaphragm cover	4	C, D										
18	83761	. Cover - Diaphragm	1	C, D										
19	*67499	. Diaphragm - Metering	1	C, D										
20	*67496	. Gasket - Diaphragm	1	C, D										
21	*67500	. Screw - Lever pin	1	C, D										
22	*67508	. Pin - Lever	1	C, D										
23	*67509	. Lever - Metering	1	C, D										
24	*67503	. Spring - Lever	1	C, D										
25	*67491	. Valve - Needle	1	C, D										
26	67483	. Body Assy - Carburetor	1	C, D										
27	*71690	. Plug - 3/8	1	C, D										
28	*69506	. Plug - 5/16	1	C, D										
29	83758	. Kit - Valve & Seat Assy	1	C, D										
30	*67507	. Screen - Fuel	1	C, D										
	*67482	Gasket Set												
	67481	Repair Kit												

*Indicates parts included in Repair Kit, P/N 67481

MCCULLOCH SDC-2 CARBURETOR ADJUSTMENT

1. Carefully turn both the high speed and idle needles clockwise until resistance is felt, then turn both needles counterclockwise one full turn.
2. With engine warmed up, adjust the idle speed screw in or out until the engine idles just below clutch engagement speed.
3. Adjust the idle mixture needle in or out (leaner or richer) to obtain smooth, rapid acceleration every time without faltering. If necessary, readjust the idle speed screw.
4. Adjust the high speed mixture needle for maximum power under load. Turn the needle in for leaner and out for richer mixture. Do not use any leaner setting than necessary to obtain smooth, even running when cutting wood.

MAC 5-10G AUTOMATIC

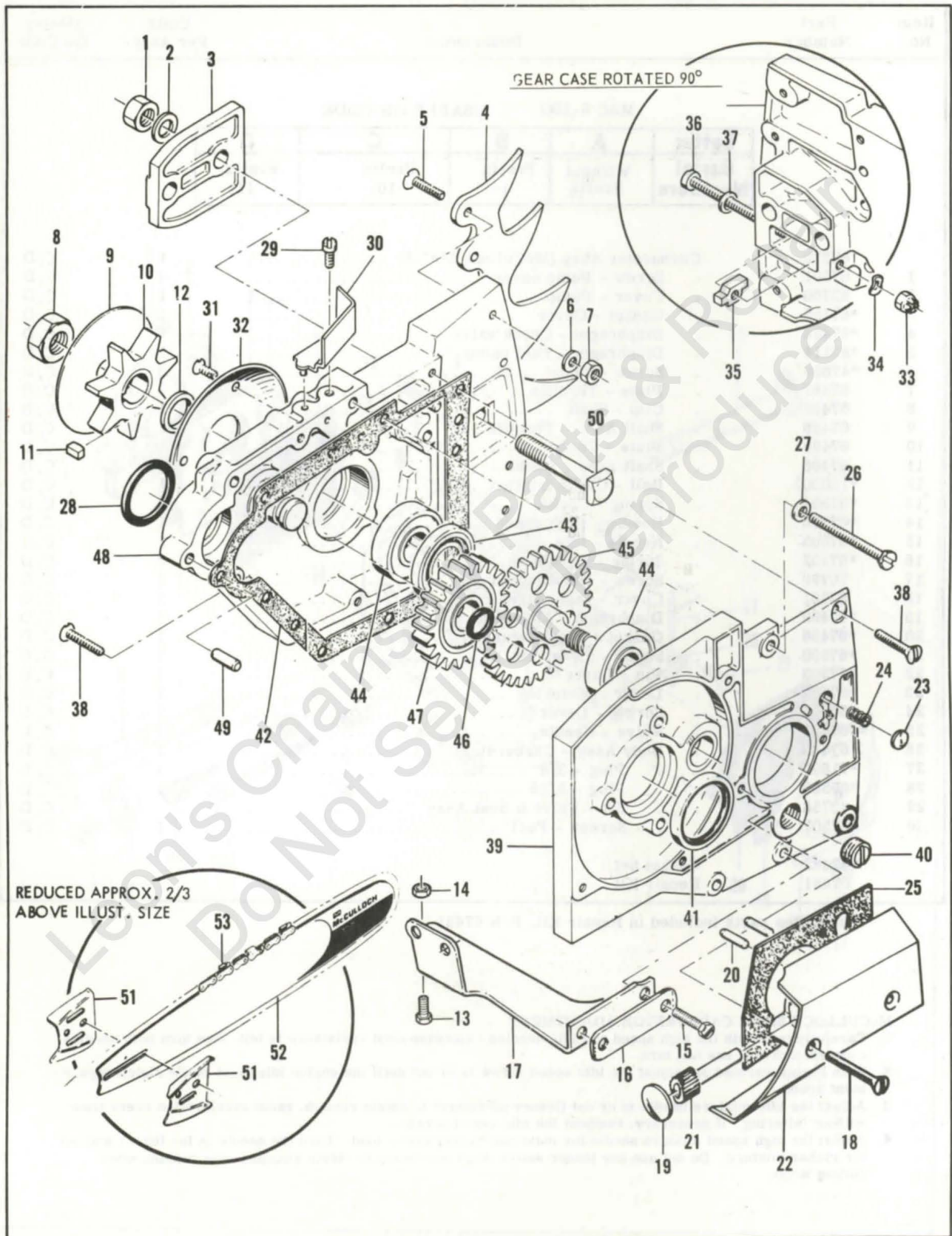

Figure 6. Transmission Assembly

Figure 6. Transmission Assembly

Item No.	Part Number	Description	Units Per Assy	Usable on Code										
MAC 5-10G USABLE ON CODE														
		<table border="1" style="width: 100%; border-collapse: collapse;"> <thead> <tr> <th style="width: 20%;">Letter</th> <th style="width: 20%;">A</th> <th style="width: 20%;">B</th> <th style="width: 20%;">C</th> <th style="width: 20%;">D</th> </tr> </thead> <tbody> <tr> <td>Serial Numbers</td> <td>Without Prefix</td> <td>Prefix 1-</td> <td>Prefix 10-</td> <td>Prefix 11-</td> </tr> </tbody> </table>	Letter	A	B	C	D	Serial Numbers	Without Prefix	Prefix 1-	Prefix 10-	Prefix 11-		
Letter	A	B	C	D										
Serial Numbers	Without Prefix	Prefix 1-	Prefix 10-	Prefix 11-										
1	110625	Nut - Hex 3/8-24	2	All										
2	100006	Washer - 3/8	2	All										
3	63417	Plate - Bar clamp	1	All										
4	63994	Kit - Spike	1	All										
5	110245	. Screw - F.l hd 10-24 x 3/4	4	All										
6	101174	. Washer - #10	4	All										
7	101191	. Nut - Hex 10-24	4	All										
8	60972	Nut - Hex 7/16-20	1	All										
9	63997A	Plate - Sprocket	1	All										
10	36644A	Sprocket	1	All										
11	63808	Key - Sprocket	1	All										
12	64754	Spacer - Sprocket	1	All										
13	103469	Screw - Hex hd 10-24 x 3/8	1	C,D										
14	105367	Nut - Hex 10-24	1	C,D										
15	102290	Screw - Hex hd 10-24 x 1-1/8	1	C,D										
16	68205	Lockplate	1	C,D										
17	67066	Brace - Gearcase	1	C,D										
18	110406	Screw - Oval hd 8-32 x 1-1/4	2	All										
	65882	Pump Assy - Oil	1	All										
19	105559	. Plug - Welch	1	All										
20	110392	. Pin - Plunger	2	All										
21	63428	. Plunger - Pump	1	All										
22	65881	. Body - Pump	1	All										
23	62909	Valve - Oiler	1	All										
24	63692	Spring - Valve	1	All										
25	63474	Gasket - Pump	1	All										
26	102765	Screw - Hex hd 10-24 x 1-3/4	2	All										
27	100003	Washer - #10	2	All										
	66208	Transmission Assy (3:1 Ratio)	1	A,B,C										
	68585	Transmission Assy (2:1 Ratio)	1	D										
28	104360	. "O" Ring	1	All										
29	110055	. Screw - Fil hd 8-32 x 3/8 (SEMS)	1	All										
30	63491	. Filler	1	All										
31	110417	. Screw - F.l hd 6-32 x 3/8	3	All										
32	63416	. Plate - Sprocket	1	All										
33	102067	. Nut - Hex 10-24	1	All										
34	110387	. Washer - Wavey	1	All										
35	63824A	. Nut - Bar adjustment	1	All										
36	102144	. Screw - Bar adjustment	1	All										
37	110264	. Washer - #10	1	All										
38	110405	. Screw - Oval hd 8-32 x 7/8	6	All										
39	64779	. Cover Assy - Gearcase (3:1 Ratio)	1	A,B,C										
	68590	. Cover Assy - Gearcase (2:1 Ratio)	1	D										
40	100432	. Plug - Filler	1	All										
41	63477	. Seal - Pinion gear	1	All										
42	68576	. Gasket - Cover	1	All										
43	63478	. Seal - Gearcase	1	All										
44	110348	. Bearing - Sprocket shaft	2	All										
45	64775	. Gear - Sprocket (3:1 Ratio)	1	A,B,C										
	67899	. Gear - Sprocket (2:1 Ratio)	1	D										
46	110452	. "O" Ring	1	All										
47	66616	. Gear Assy - Idler (3:1 Ratio)	1	A,B,C										
	67896	. Gear Assy - Idler (2:1 Ratio)	1	D										

MAC 5-10G
AUTOMATIC

Figure 6. Transmission Assembly

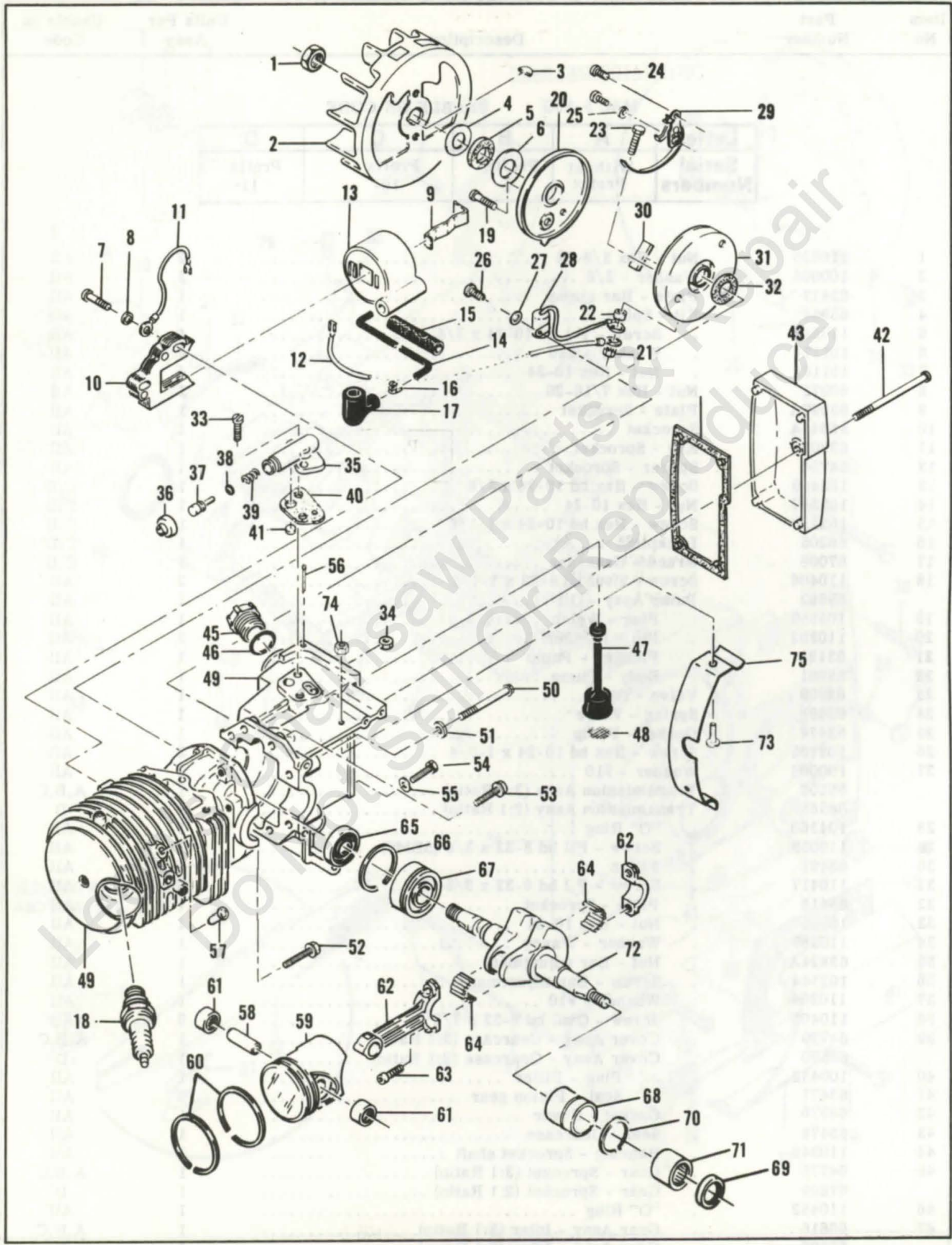

Figure 7. Powerhead Assembly

Figure 6. Transmission Assembly (Continued)

Item No.	Part Number	Description	Units Per Assy	Usable on Code
48	64770	. Gearcase (3:1 Ratio)	1	A,B,C
	68587	. Gearcase (2:1 Ratio)	1	D
49	101770	. . Pin - Dowel	2	All
50	64584	. . Bolt - Bar	2	All
51	64935	Plate - Bar protector	2	All
52		Bar	1	All
53		Chain Assy	1	All

Figure 7. Powerhead Assembly

Item No.	Part Number	Description	Units Per Assy	Usable on Code															
<table border="1"> <tr> <td colspan="2">MAC 5-10G</td> <td colspan="3">USABLE ON CODE</td> </tr> <tr> <td>Letter</td> <td>A</td> <td>B</td> <td>C</td> <td>D</td> </tr> <tr> <td>Serial Numbers</td> <td>Without Prefix</td> <td>Prefix 1-</td> <td>Prefix 10-</td> <td>Prefix 11-</td> </tr> </table>					MAC 5-10G		USABLE ON CODE			Letter	A	B	C	D	Serial Numbers	Without Prefix	Prefix 1-	Prefix 10-	Prefix 11-
MAC 5-10G		USABLE ON CODE																	
Letter	A	B	C	D															
Serial Numbers	Without Prefix	Prefix 1-	Prefix 10-	Prefix 11-															
1	101391	Nut - Hex 3/8-24	1	All															
2	84681	Flywheel	1	All															
3	103879	Key - Woodruff	1	All															
4	67057	Washer - Thrust	1	C,D															
5	67056	Seal	1	C,D															
6	67054	Washer - Thrust	1	C,D															
7	110127	Screw - Hex hd 10-24 x 7/8 (SEMS)	2	All															
8	100003	Washer - #10	2	All															
9	51253	Retainer - Coil	1	All															
10	85138	Lamination Assy	1	All															
11	62819	Wire Assy - Ground	1	All															
12	69344	Wire Assy - Primary	1	All															
13	84972	Coil & Terminal Assy	1	All															
14	69966	. Wire Assy - Spark plug	1	All															
15	67127	. . Sleeve	1	All															
16	62932	. . Connector	1	All															
17	62926	. . Boot	1	All															
18	63432	Spark Plug	1	All															
19	110349	Screw - Rd hd 8-32 x 3/4	1	All															
20	62362	Cover - Breaker box	1	All															
21	100298	Nut - Hex 6-32	1	All															
22	62365	Spacer - Breaker screw	1	All															
23	110346	Screw - Hex hd 6-32 x 3/4	1	All															
24	100934	Screw - Rd hd 8-32 x 3/8	1	All															
25	105976	Washer - #8	1	All															
26	105249	Screw - Rd hd 8-32 x 3/8 (SEMS)	1	All															
27	100080	Washer - #8	1	All															
28	85358	Condenser	1	All															
29	62363	Breaker Assy	1	All															
30	54184	Wiper - Cam	1	All															
31	62361	Box - Breaker	1	All															
32	67051	Seal - Box	1	C,D															
33	110623	Screw - Fil hd 8-32 x 1/2	2	All															
34	100955	Nut - Hex 8-32	1	All															
35	84156	Housing - Pump	1	All															
36	62262	Cap - Housing	1	All															
37	62266	Plunger - Pump	1	All															

Figure 7. Powerhead Assembly (Continued)

Item No.	Part Number	Description	Units Per Assy	Usable on Code
38	101056	"O" Ring	1	All
39	66687	Spring - Plunger	1	All
40	62230	Gasket - Pump	1	All
41	62909	Valve - Pump	1	All
42	110407	Screw - Pan hd 10-24 x 3-1/2	1	All
43	63974	Cover - Oil tank	1	All
44	63442	Gasket - Cover	1	All
45	57129A	Cap - Oil	1	All
46	101148	"O" Ring	1	All
47	62123B	Hose Assy - Oil	1	All
48	51506	. Screen - Hose	1	All
49	67120	Crankcase Assy	1	All
50	62105	. Screw Assy - Sealing	4	All
51	62842	. Washer - Sealing	4	All
52	110404	. Screw - Hex hd 8-32 x 7/8	1	All
53	110288	. Screw - Hex hd 8-32 x 3/4	2	All
54	63607	. Screw Assy - Sealing	1	All
55	63606	. Washer - Sealing	1	All
56	100010	. Pin - Cotter	1	All
57	83137	. Valve - DSP	1	All
	65910	Valve - DSP	1	A
58	65389	Pin - Piston	1	All
59	85239	Piston Assy	1	All
60	85241	. Ring Set - Piston	1	All
61	103085	. Bearing - Needle	2	All
62	65401	Connecting Rod Assy	1	All
63	61627A	. Screw - Skt hd special	2	All
64	63225	. Roller - Needle (set of 20)	1	All
65	61618	Seal - Oil	1	All
66	63464	Ring - Snap	1	All
67	63429B	Bearing - Ball	1	All
68	63492	Insert & Bearing Assy	1	All
69	110260	. Seal - Oil	1	All
70	63699	. Ring - Insert	1	All
71	104357	. Bearing - Needle	1	All
72	84654	Crankshaft	1	All
73	105221	Screw - Rd hd 10-24 x 5/16	2	All
74	101191	Nut - Hex 10-24	2	All
75	65363	Guard - Crankcase	1	All

Accessories

Item No.	Part Number	Description	Units Per Assy	Usable on Code
	61040	Wrench - Screwdriver		
	65712	Guide - Timing		
	67067	Kit - Gearcase brace		
	68052	Plate - Wear		
	84922	Baffle - Spark arrester		
	63097	Spark Plug - AC CS 45T		
	65778	Spark Plug - AC CS 41T		
	*69413	Piston Assy - 0.020 in. oversize		
	*63291	. Ring Set - Piston 0.020 in. oversize		
	103085	. Bearing - Needle (2)		
	*69414	Piston Assy - 0.030 in. oversize		
	*63292	. Ring Set - Piston 0.030 in. oversize		
	103085	. Bearing - Needle (2)		

*For use in cylinders with cast iron liners only.

**40:1 TWO-CYCLE
MOTOR OIL**

Reduces smoke,
carbon and engine wear.



6 oz. can # 78960
6-pack # 78961
16 oz. can # 78963
6-pack # 78964
1 qt. bottle # 110626

**CHAIN, BAR AND
SPROCKET OIL**

Specially designed for
extra lubrication of bars
and chains.



1 qt. bottle # 110631
Case of 24 # 110632

BAR GUARDS

Protect bar and chain
from accidental
damage.

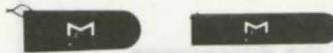

A B
Black Polyvinylchloride

(A) for wide bars # 56927
(B) narrow bars # 64930



C D
Rigid Yellow Plastic

(C) MAC 10-16, 20" # 66544
(D) PM 6-12, 16" # 83124

LOCQUIC AND

Primer. Cleans,
degreases, and
accelerates curing.

7-1/2 oz. spray can.
69794



LOCTITE

Sealant, bonding
agent

10cc plastic
bottle
67537



SPRAY PAINT

Black
12 oz. can # 103503
Case of 12 # 103400



Yellow
12 oz. can # 102249
Case of 12 # 102464

STARTER ROPE

Solid, braided nylon



100' spool
36825

PRESSURE TEST TOOLS

For leakage check
of crankcase,
fuel system.



Basic unit
62849

CHAIN SHARPENING TOOLS

		The ● shows which tools are used on chains				
		S-25	SM-57	S-40	S-80	S-90
<p>McCULLOCH FILES</p>	1/8" round	●				
	5/32" round	●	●			
	3/16" round		●			
	7/32" round		●	●		
	1/4" round				●	
	9/32" round					●
8" flat	●	●	●	●	●	
6" flat safety	●	●	●	●	●	
<p>FILE GUIDE & FILE</p>						
#67750 (1/8" round)		●				
#60950 (7/32" round)			●			
(Also holds 3/16 and 1/4" round)				●		
<p>DEPTH GAUGE TOOLS</p>						
#56241	.045-.060"			●	●	●
#64198	.035-.060"			●	●	●
#64359	.045-.050"			●	●	●
#67688	.015-.020"	●				
#67680	.025-.030"	●	●	●	●	●
<p>FILE-N-JOINT Assures correct filing angle, height.</p>						
#61034		●	●	●	●	●

GEAR OIL (SAE 140)

For transmissions of
gear drive saws.



16 oz. can # 19342
Case of 24 # 104347

**"BREAK ALL"
CHAIN BREAKER**

Required when
repairing chain.

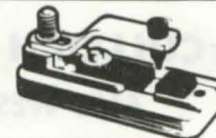

61753
Instructions included.

The information contained in this Master Illustrated Parts List is based on original Illustrated Parts Lists, Engineering Records and the Master Parts Price List and is accurate to the best of our knowledge.

Each chain saw model is given a code letter. Whenever the code letter appears in the right hand column, the part is used on the engines of the model for which the code letter stands. When a part is used on all models covered in the Master Illustrated Parts List, the word "All" appears in the right-hand column instead of the code letters.

Names of parts have been checked and made to agree with the names given in the Master Parts Price List except in a very few cases where additional nomenclature was required.

The illustrations of the individual parts do not necessarily picture all the differences between parts with the same item number because the illustrations would be too complicated for use if they did. Instead, the illustration shows a representative part for each item number.



McCULLOCH



● MANUFACTURING ●

SALES ●

SERVICE ●

McCULLOCH CORPORATION

6101 WEST CENTURY BLVD., LOS ANGELES, CALIFORNIA 90045

INTERNATIONAL DIVISIONS:

LOS ANGELES, CALIF., P.O. BOX 45466

BUENOS AIRES, ARGENTINA: CASILLA DE CORREO 2467

SINGAPORE, 431-432 PEOPLE'S PARK COMPLEX

McCULLOCH OF CANADA LTD.

6338 VISCOUNT ROAD, MALTON, ONTARIO, CANADA

McCULLOCH OF EUROPE, N. V.

ANTOON SPINOYSTRAAT, 5, B-2800 MECHELEN, BELGIUM

McCULLOCH OF AUSTRALIA PTY., LTD.

P.O. BOX 223, SEVEN HILLS, N.S.W. 2147, AUSTRALIA