

# MASTER ILLUSTRATED PARTS LIST

## MAC 5-10E Chain Saw

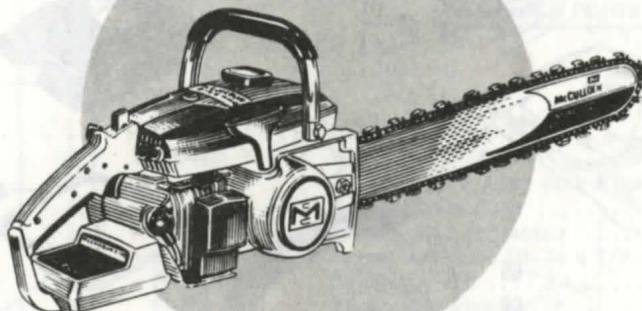

July 1971

### CONTENTS

	Page
Figure 1. General . . . . .	2
Figure 2. Clutch Guard & Starter Assembly . . . . .	6
Figure 3. Fuel Tank Assembly . . . . .	8
Figure 4. Carburetor Assembly . . . . .	10
Figure 5. Carburetor Assembly . . . . .	12
Figure 6. Electrical Components . . . . .	14
Figure 7. Powerhead Assembly . . . . .	18

The policy of McCulloch Corporation is one of continual improvement in design, manufacturing and engineering advancement wherever possible to assure still finer two-cycle power tools. Hence, specifications, equipment, colors, design and manufacturer's suggested list prices are subject to change without notice and McCulloch Corporation reserves the right to make such changes without prior notification or obligation to backfit or supply backfit components for units previously shipped from the factory.

This Master Illustrated Parts List gives the name, number and interchangeability between engines, of service and replacement parts which were used on or are presently available for all MAC 5-10E chain saws manufactured to date.

Information about the List and how to use it will be found on the back cover.  
Read the information before you start to use the List.



# MAC 5-10E

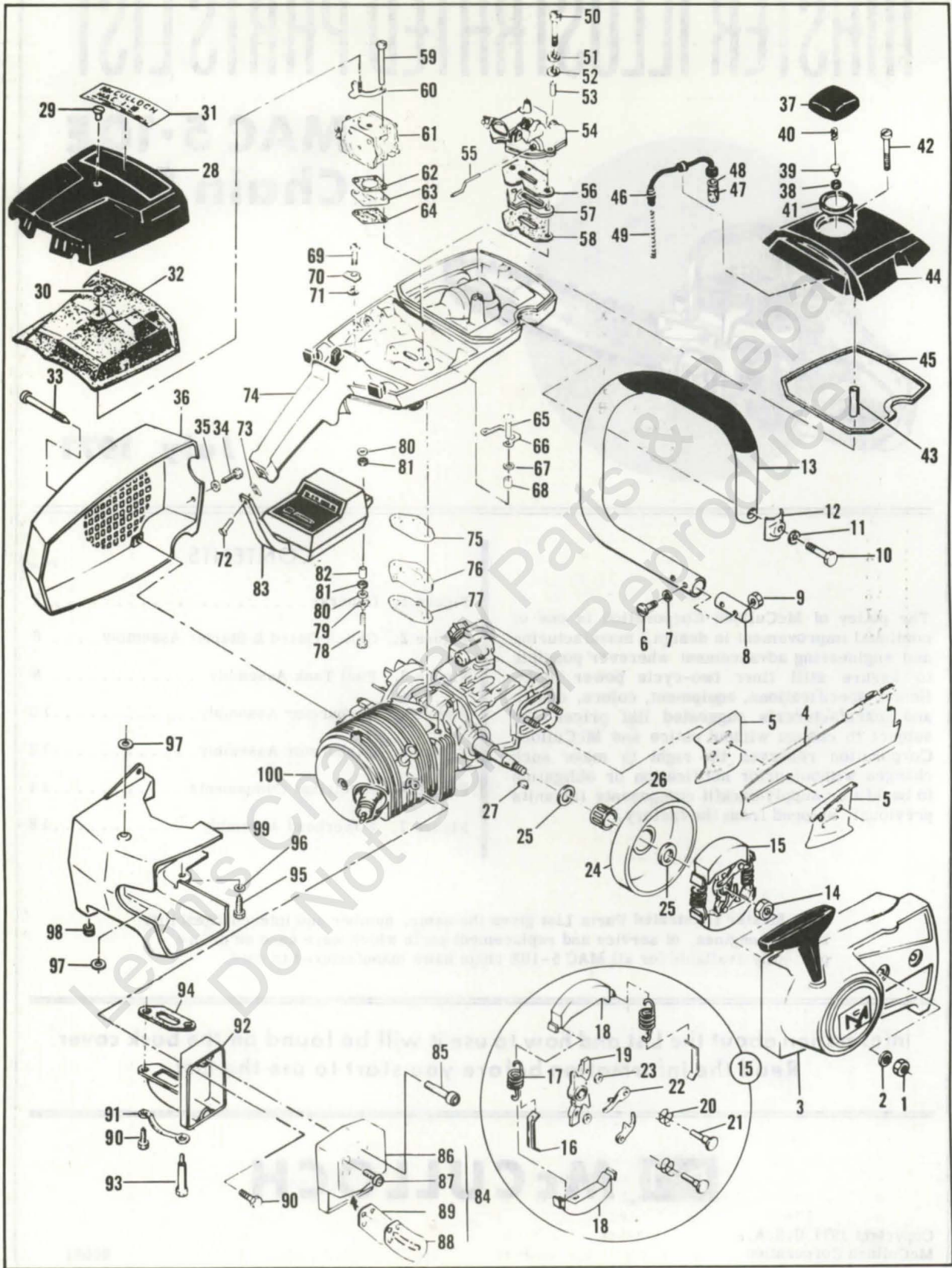

Figure 1. General

FIGURE 1. GENERAL

Item No.	Part Number	Description	Units Per Assy	Usable On Code								
MAC 5-10E Usable on code												
<table border="1"> <thead> <tr> <th>Number</th> <th>A</th> <th>B</th> <th>C</th> </tr> </thead> <tbody> <tr> <td>Serial Numbers</td> <td>Without Prefix</td> <td>Prefixed 1-</td> <td>Prefixed 10-</td> </tr> </tbody> </table>					Number	A	B	C	Serial Numbers	Without Prefix	Prefixed 1-	Prefixed 10-
Number	A	B	C									
Serial Numbers	Without Prefix	Prefixed 1-	Prefixed 10-									
1	110454	Nut - Hex 5/16-24	2	All								
2	100440	Washer - 5/16	2	All								
3		Clutch Guard Assy (See Figure 2)		All								
4		Bar & Chain Assy	1	All								
5	64325	Plate - Bar protector	2	All								
6	102761	Screw - Hex hd 10-24 x 7/8	2	All								
7	100352	Washer - #10	2	All								
8	61678	Plug - Nut retainer	1	All								
9	101326	Nut - Hex 10-24	2	All								
10	102130	Screw - Hex hd 1/4-20 x 1-1/2	1	All								
11	100153	Lockwasher - 1/4	1	All								
12	63484	Clamp	1	All								
13	66315	Frame & Grip Assy	1	All								
14	103746	Nut - Hex 3/8-24	1	All								
15	67148	Clutch Assy	1	All								
16	64583	. Retainer - Spring	2	All								
17	66384	. Spring - Clutch	2	All								
18	67233	. Shoe - Clutch	2	All								
19	67149	. Rotor Assy - Clutch	1	All								
20	68837	. . Spring - Pawl	2	All								
21	67112	. . Rivet - Pawl	2	All								
22	64857	. . Pawl - Starter	2	All								
23	65473	. . Washer - Special	2	All								
24	65370	Kit - Sprocket & Drum Assy	1	All								
25	61692	. Shim - Sprocket	2	All								
26	110330	Bearing - Sprocket	1	All								
27	103879	Key - Woodruff	1	All								
28	65750	Cover Assy - Air cleaner	1	A,B								
	66597	Cover Assy - Air cleaner	1	C								
29	65720	. Nut - Cover	1	A,B								
	66290	. Nut - Cover	1	C								
30	66665	. Spacer - Nut	1	C								
31	67448	Nameplate	1	All								
32	68521	Screen - Air filter	1	All								
33	64626	Screw - Special	3	All								
34	105348	Screw - Hex hd 10-24 x 1/2 (SEMS)	1	All								
35	110264	Washer - #10	1	All								
36	67297	Housing - Fan	1	All								
37	68531	Cap Assy - Fuel	1	All								
38	68533	. Plug	1	All								
39	63041	. Valve	1	All								
40	63040	. Spring	1	All								
41	69767	. Gasket	1	All								
42	110402	Screw - Oval hd 12-24 x 2-3/8	1	All								
43	69686	Spacer - Screw	1	All								
44	63288	Cover - Fuel tank	1	All								
45	69345	Gasket - Cover	1	All								
46	64848	Hose Assy - Fuel	1	All								
47	63932	. Filter	1	All								
48	100440	. Washer	1	All								
49	67944	Spring - Hose stiffener	1	All								
50	110551	Screw - Hex hd 10-24 x 2-1/8	2	A,B								

FIGURE 1. GENERAL (CONT)

Item No.	Part Number	Description	Units Per Assy	Usable On Code
51	64856	Washer - Special	2	A,B
52	68203	Washer - Insulator	2	A,B
53	65726	Sleeve - Insulator	2	A,B
54		Carburetor Assy (See Figure 4)		A,B
55	65758	Rod - Primer	1	A,B
56	65739	Gasket - Carburetor	1	A,B
57	66232	Insulator - Carburetor	1	A,B
58	68129	Gasket - Insulator	1	A,B
59	110551	Screw - Hex hd 10-24 x 2-1/8	2	C
60	66681	Bracket Assy	1	C
61		Carburetor Assy (See Figure 5)		C
62	68132	Gasket - Carburetor	1	C
63	84078	Spacer - Carburetor	1	C
64	68131	Gasket - Spacer	1	C
65	110553	Screw - Hex hd 10-24 x 1-3/8	2	C
66	68582	Lockplate	1	C
67	100003	Washer - #10	2	C
68	66189	Sleeve	2	C
69	110516	Screw - Hex hd 10-24 x 1-1/8	1	All
70	63475	Lockplate	1	All
71	64856	Washer - Special	1	All
72	110223	Screw - Oval hd 10-24 x 5/8 (SEMS)	1	All
73	66672	Cushion - Handle brace	1	B,C
74		Fuel Tank Assy (See Figure 3)		All
75	84082	Gasket - Fuel tank	1	All
76	66661	Insulator - Fuel tank	1	All
77	65741	Gasket - Insulator	1	All
78	102290	Screw - Hex hd 10-24 x 1-5/8	1	All
79	69890	Lockplate	1	A
	66673	Lockplate	1	B,C
80	105831	Washer - Steel	2	B,C
81	71017	Washer - Rubber	2	B,C
82	66674	Sleeve - Handle brace	1	B,C
83		Handle Brace and Battery Assy (See Figure 6)		All
84	68191	Kit - Spark arrester	1	All
85	110473	Screw - Skt hd 10-24 x 1-5/8	2	All
86	65532	Cover & Valve Assy	1	All
87	110472	Screw - Skt hd 8-32 x 5/16	3	All
88	84780	Stop - Reed	1	All
89	84779	Valve - Reed	1	All
90	110529	Screw - Hex hd 10-24 x 1/2	2	All
91	67922	Lockplate	1	All
92	83106	Kit - Body & Duct Assy	1	All
93	68187	Screw - Special	1	All
94	68149	Gasket - Spark arrester	1	All
95	103469	Screw - Hex hd 10-24 x 3/8	1	All
96	100352	Washer - #10	1	All
97	68581	Insulator - Shroud	1	All
98	101230	Grommet - Shroud	1	All
99	67910	Shroud	1	All
100		Powerhead Assy (See Figure 7)		All

ACCESSORIES

Part Number	Description
83434	Manual - Owner's
63084	Manual - Shop
62827	Wrench
63341A	Kit - Spike
69058	Kit - Wrap-around frame
63746	Scrench
84922	Baffle - Spark arrester
64330	Plate Set - Bar protector (2)
63490	Tool - Fuel orifice
65712	Guide - Timing

Part Number	Description
67098	Charger Assy - Battery
65778	Spark Plug - AC CS 41 T
69413	Piston Assy - 0.020 in. oversize
63291	. Ring Set - Piston 0.020 in. oversize
103085	. Bearing - Needle (2)
69414	Piston Assy - 0.030 in. oversize
63292	. Ring Set - Piston 0.030 in. oversize
103085	. Bearing - Needle (2)

Master Illustrated Parts List, P/N 86081, supersedes and cancels all previous lists issued for the MAC 5-10E saw. Discard the following lists:

IPL 65666 and

Parts list sheet 66654 covering saws having serial numbers without prefix.

Parts list sheet 66838 covering saws having serial numbers prefixed 1-

IPL 67449 covering saws having serial numbers prefixed 10-.

SERVICE SPECIFICATIONS

Spark Plug Gap -----	0.025 in.
Lamination Gap -----	0.010 to 0.015 in.
Breaker Point Gap -----	0.018 in.
Torque Values	
Flywheel Nut -----	240 to 300 inch-pounds.
Clutch Nut-----	160 to 170 inch-pounds.
Connecting Rod Screws -----	65 to 70 inch-pounds.

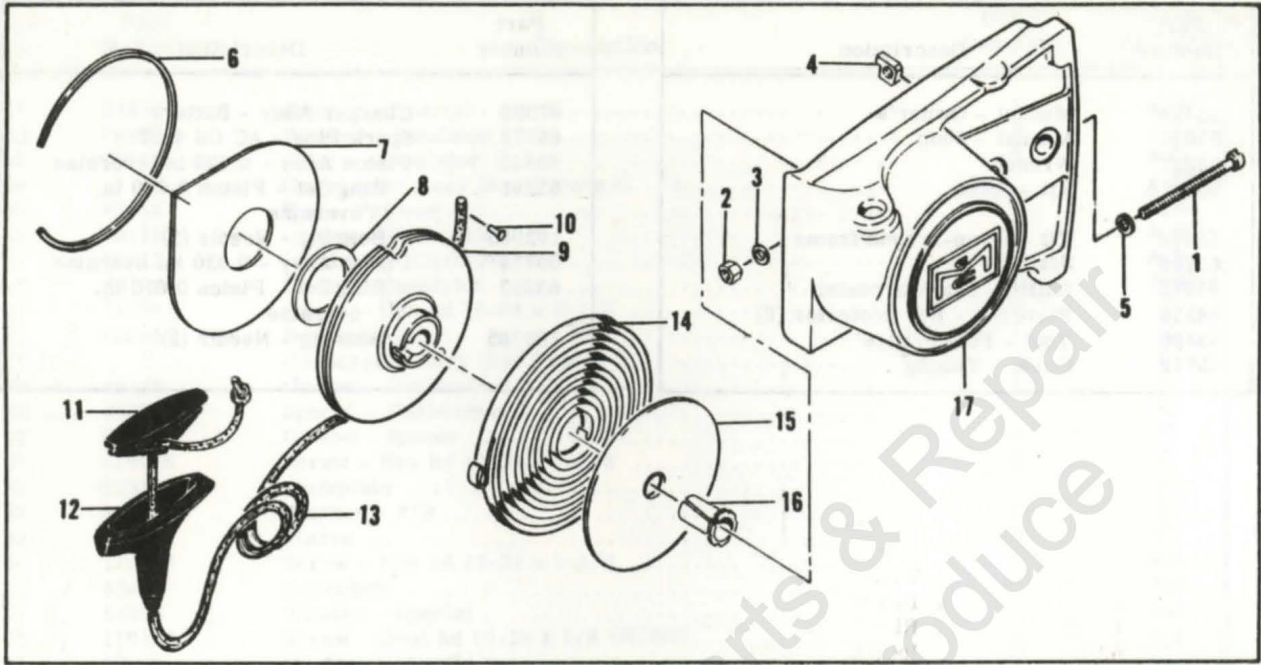

Figure 2. Clutch Guard & Starter Assembly

Leon's Chainsaw Parts & Repair  
Do Not Sell Or Reproduce

Service Specifications

FIGURE 2. CLUTCH GUARD AND STARTER ASSEMBLY

Item No.	Part Number	Description	Units Per Assy	Usable On Code								
MAC 5-10E Usable on code												
<table border="1"> <thead> <tr> <th>Number</th> <th>A</th> <th>B</th> <th>C</th> </tr> </thead> <tbody> <tr> <td>Serial Numbers</td> <td>Without Prefix</td> <td>Prefixed 1-</td> <td>Prefixed 10-</td> </tr> </tbody> </table>					Number	A	B	C	Serial Numbers	Without Prefix	Prefixed 1-	Prefixed 10-
Number	A	B	C									
Serial Numbers	Without Prefix	Prefixed 1-	Prefixed 10-									
	83850	Clutch Guard Assy .....	1	All								
1	102144	. Screw - Bar adjusting .....	1	All								
2	102067	. Nut - Hex 10-24 .....	1	All								
3	110387	. Washer - Wavey .....	1	All								
4	61705	. Nut - Bar adjusting .....	1	All								
5	110264	. Washer - #10 .....	1	All								
6	67205	. Retainer - Shield .....	1	All								
7	63985	. Shield - Dust .....	1	All								
8	63986	. Washer - Thrust .....	1	All								
9	83651	. Drum - Starter .....	1	All								
10	110470	. Rivet - Starter rope .....	1	All								
11	62191A	. Insert - Handle .....	1	All								
12	62190A	. Handle - Starter .....	1	All								
13	69964	. Rope - Starter .....	1	All								
14	68626	. Spring - Rewind .....	1	All								
15	63987	. Shield - Spring .....	1	All								
16	61635A	. Bushing - Nyliner .....	1	All								
17	83569	. Guard - Clutch .....	1	All								

Leon's Chainsaw Parts & Repair  
Do Not Sell Or Reproduce

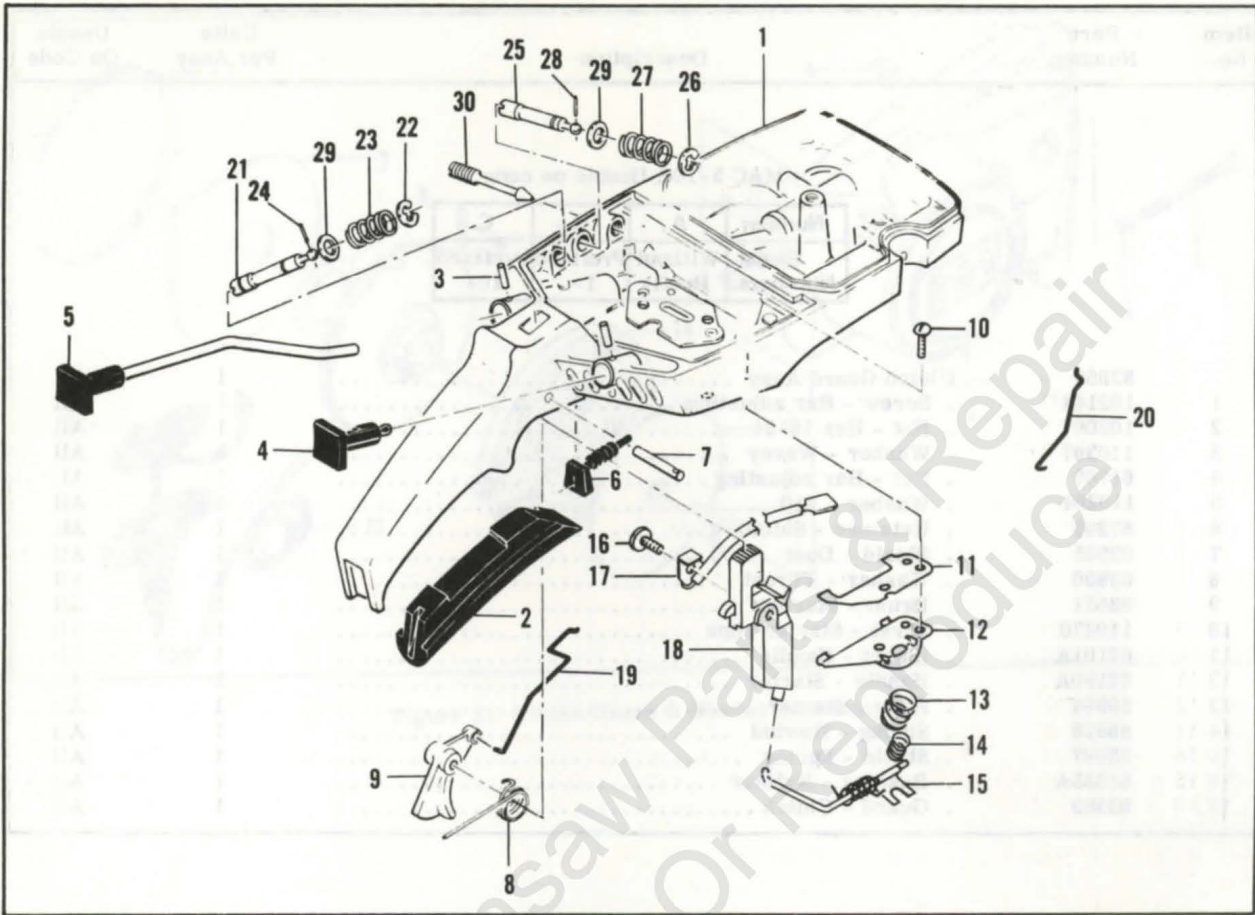

Figure 3. Fuel Tank Assembly

Leon's Chainsaw Parts & Repair  
Do Not Sell Or Reproduce



FIGURE 3. FUEL TANK ASSEMBLY

Item No.	Part Number	Description	Units Per Assy	Usable On Code								
MAC 5-10E Usable on code												
<table border="1"> <thead> <tr> <th>Number</th> <th>A</th> <th>B</th> <th>C</th> </tr> </thead> <tbody> <tr> <td>Serial Numbers</td> <td>Without Prefix</td> <td>Prefixed 1-</td> <td>Prefixed 10-</td> </tr> </tbody> </table>					Number	A	B	C	Serial Numbers	Without Prefix	Prefixed 1-	Prefixed 10-
Number	A	B	C									
Serial Numbers	Without Prefix	Prefixed 1-	Prefixed 10-									
1	66649	Fuel Tank Assy	1	A,B								
	84183	Fuel Tank Assy	1	C								
2	64872	Grip - Handle	1	All								
3	105673	Pin - Roll 3/32 x 9/16	2	All								
4	66194	Button - Primer	1	A,B								
	68517	Button - Choke	1	C								
5	64871	Button & Rod Assy - Oiler	1	All								
6	67989	Seal - Throttle rod	1	All								
7	110378	Pin - Roll 3/16 x 15/16	1	All								
8	65734	Spring - Throttle return	1	All								
9	67224	Trigger	1	All								
10	105249	Screw - Rd hd 8-32 x 3/8	2	All								
11	64621	Shield	1	All								
12	64721	Bracket - Lever assy	1	All								
13	69687	Spring - Valve	1	All								
14	66246	Spring - Valve (inner)	1	A,B								
15	69811	Lever Assy - DSP	1	All								
16	110469	Screw - Pan hd 8-32 x 5/16	1	All								
17	65873	Wire Assy - Stop switch	1	All								
18	67210	Button - Control	1	All								
19	66156	Rod - Throttle	1	A,B								
	68170	Rod - Throttle	1	C								
20	67355	Rod - Choke	1	C								
21	68102	Extension Assy - High speed	1	C								
22	110512	Ring - Retaining	1	C								
23	67363	Spring - Extension	1	C								
24	110509	Pin - Groove	1	C								
25	68101	Extension Assy - Idle	1	C								
26	110512	Ring - Retaining	1	C								
27	67363	Spring - Extension	1	C								
28	110509	Pin - Groove	1	C								
29	67292	Washer - Special	2	C								
30	67271	Screw - Idle speed adjustment	1	C								

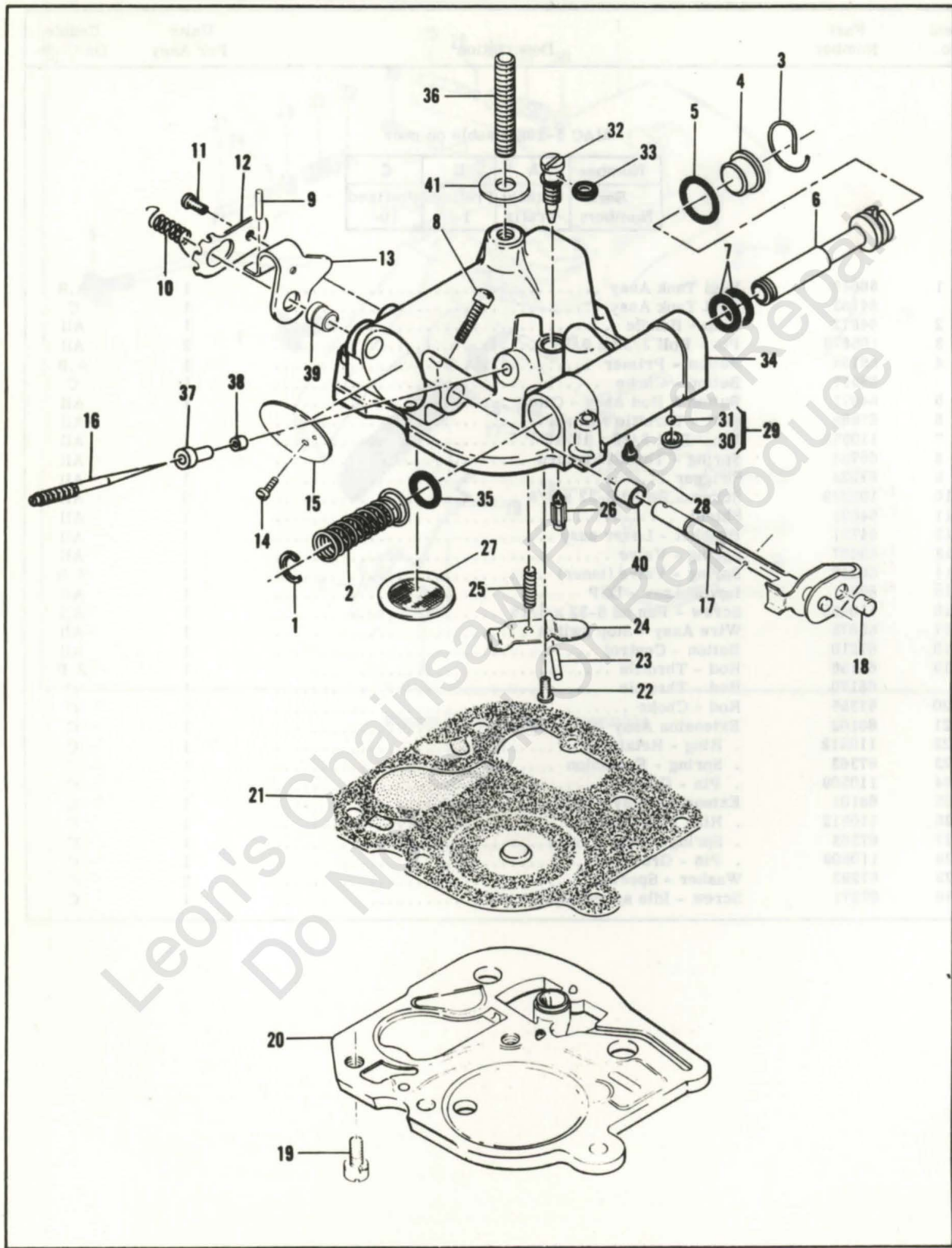

Figure 4. Carburetor Assembly

FIGURE 4. CARBURETOR ASSEMBLY

Item No.	Part Number	Description	Units Per Assy	Usable On Code								
MAC 5-10E Usable on code												
<table border="1"> <thead> <tr> <th>Number</th> <th>A</th> <th>B</th> <th>C</th> </tr> </thead> <tbody> <tr> <td>Serial Numbers</td> <td>Without Prefix</td> <td>Prefixed 1-</td> <td>Prefixed 10-</td> </tr> </tbody> </table>					Number	A	B	C	Serial Numbers	Without Prefix	Prefixed 1-	Prefixed 10-
Number	A	B	C									
Serial Numbers	Without Prefix	Prefixed 1-	Prefixed 10-									
	66511	Carburetor Assy (McCulloch Double Needle) .....	1	A,B								
1	101289	. Ring - Retaining .....	1	A,B								
2	65859	. Spring - Plunger .....	1	A,B								
3	65677	. Retainer - Plug .....	1	A,B								
4	65617	. Plug - Primer .....	1	A,B								
5	105617	. "O" Ring .....	1	A,B								
6	66552	. Plunger - Primer .....	1	A,B								
7	66551	. "O" Ring .....	2	A,B								
8	110483	. Screw - Long locking .....	1	A,B								
9	104245	. Pin - Roll .062 x 1/2 .....	1	A,B								
10	62939A	. Spring - Idle governor .....	1	A,B								
11	103934	. Screw - Rd hd 6-32 x 1/4 (SEMS) .....	1	A,B								
12	62938	. Clip - Throttle shaft .....	1	A,B								
13	62343A	. Lever - Throttle .....	1	A,B								
14	104814	. Screw - Pan hd 4-40 x 1/4 (SEMS) .....	1	A,B								
15	62290A	. Plate - Throttle .....	1	A,B								
16	65431	. Needle - Metering .....	1	A,B								
17	62291A	. Shaft Assy - Throttle .....	1	A,B								
18	62975	. Swivel - Needle .....	1	A,B								
19	110397	. Screw - Pan hd 8-32 x 7/16 (SEMS) .....	4	A,B								
20	66507	. Plate - Carburetor base .....	1	A,B								
21	65608	. Diaphragm Assy - Pump .....	1	A,B								
22	104728	. Screw - Bind hd 6-32 x 1/4 .....	1	A,B								
23	110337	. Pin - Inlet lever .....	1	A,B								
24	62310	. Lever - Inlet .....	1	A,B								
25	62923A	. Spring - Inlet lever .....	1	A,B								
26	63038	. Valve - Inlet needle .....	1	A,B								
27	55690B	. Seal - Capillary .....	1	A,B								
28	63041	. Valve - Primer .....	1	A,B								
29	65868	. Set - Ball and seat .....	1	A,B								
30	66153	. . . . . Seat .....	1	A,B								
31	61151	. . . . . Ball .....	1	A,B								
32	65445	. Needle - Main fuel .....	1	A,B								
33	104001	. "O" Ring .....	1	A,B								
34	66512	. Body Assy - Carburetor .....	1	A,B								
35	59796	. . "O" Ring .....	1	A,B								
36	65724	. . Stud - Carburetor .....	1	A,B								
37	66158	. . Orifice - Air .....	1	A,B								
38	66569	. . Orifice - Fuel .....	1	A,B								
39	62288A	. . Bushing - Throttle shaft .....	1	A,B								
40	62368	. . Bushing - Throttle shaft .....	1	A,B								
41	67062	Seal - Carburetor stud .....	1	A,B								

**MCCULLOCH DOUBLE NEEDLE CARBURETOR ADJUSTMENT**

1. Turn Lo Speed screw counterclockwise until it no longer touches stop and butterfly can be completely closed.
2. Hold finger against closed butterfly and turn Lo Mix needle clockwise until butterfly starts to open. Turn the needle counterclockwise two and one half turns.
3. Hold finger against closed butterfly and turn Lo Speed screw clockwise until butterfly starts to open. Turn the screw clockwise one half turn more.
4. Turn Hi Mix needle clockwise until resistance is felt, then turn the needle counterclockwise two full turns.
5. Turn the Lo Mix needle to obtain smooth rapid acceleration every time without faltering. Check for smooth idle for all positions of the saw and readjust the Lo Mix needle if necessary.
6. Adjust Hi Mix needle for maximum power under load. Turn the needle in for leaner and out for richer mixture. Do not adjust the needle for leaner mixture than necessary to obtain smooth, even running under a cutting load.

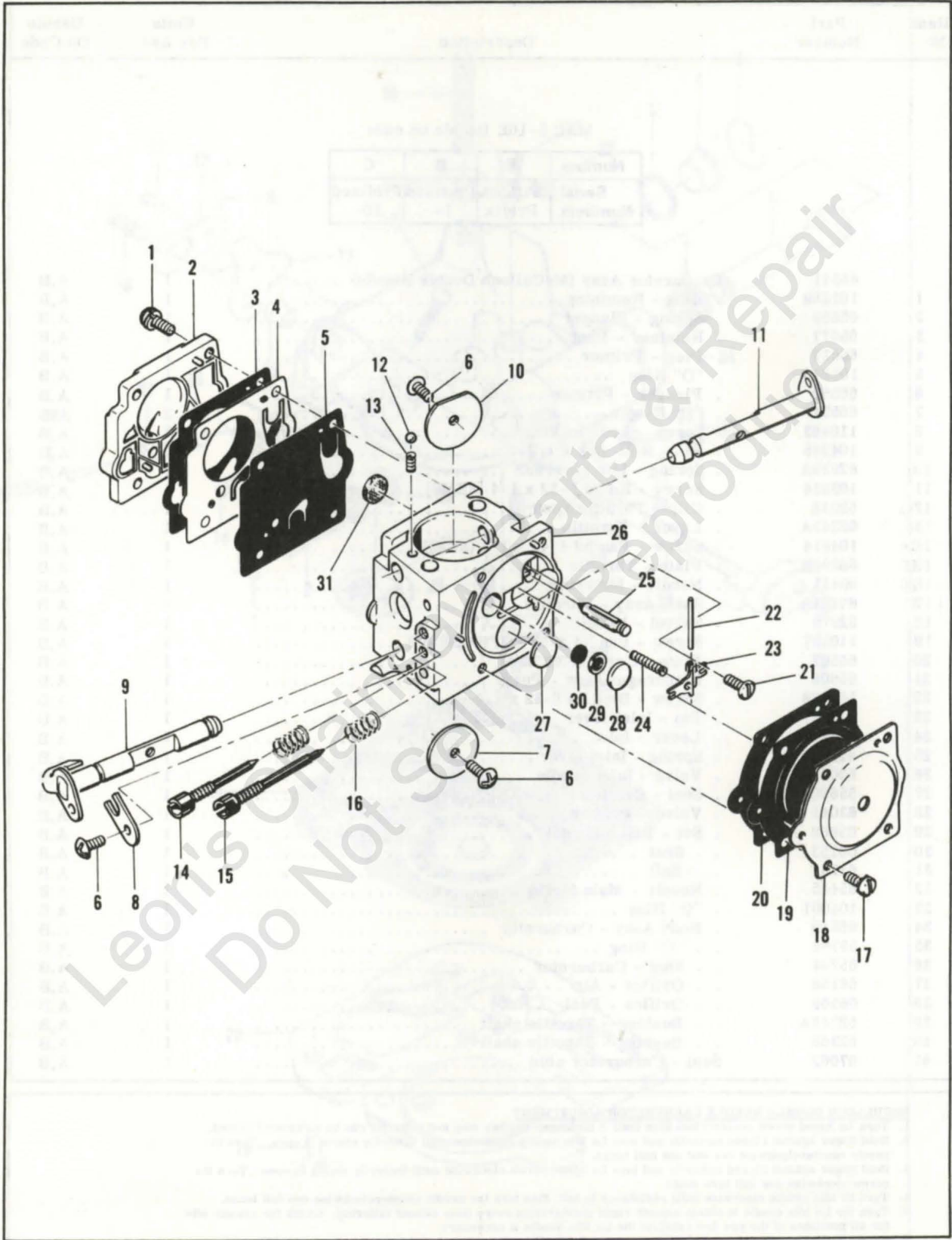

Figure 5. Carburetor Assembly

FIGURE 5. CARBURETOR ASSEMBLY

Item No.	Part Number	Description	Units Per Assy	Usable On Code								
MAC 5-10E Usable on code												
<table border="1"> <thead> <tr> <th>Number</th> <th>A</th> <th>B</th> <th>C</th> </tr> </thead> <tbody> <tr> <td>Serial Numbers</td> <td>Without Prefix</td> <td>Prefixed 1-</td> <td>Prefixed 10-</td> </tr> </tbody> </table>					Number	A	B	C	Serial Numbers	Without Prefix	Prefixed 1-	Prefixed 10-
Number	A	B	C									
Serial Numbers	Without Prefix	Prefixed 1-	Prefixed 10-									
	67379	Carburetor Assy (McCulloch SDC-2) .....	1	C								
1	67501	. Screw - Pump cover .....	4	C								
2	83760	. Cover - Pump .....	1	C								
3	*67495	. Gasket - Cover .....	1	C								
4	*67498	. Diaphragm - Check valve .....	1	C								
5	*83114	. Diaphragm - Fuel pump .....	1	C								
6	*47690	. Screw - Plate .....	3	C								
7	67487	. Plate - Throttle .....	1	C								
8	67489	. Clip - Shaft .....	1	C								
9	67486	. Shaft Assy - Throttle .....	1	C								
10	67490	. Plate - Choke .....	1	C								
11	67488	. Shaft Assy - Choke .....	1	C								
12	*100302	. Ball - Choke friction .....	1	C								
13	*67504	. Spring - Choke .....	1	C								
14	*67506	. Needle - High speed .....	1	C								
15	*67505	. Needle - Idle .....	1	C								
16	*67502	. Spring - Needle .....	2	C								
17	70798	. Screw - Diaphragm cover .....	4	C								
18	83761	. Cover - Diaphragm .....	1	C								
19	*67499	. Diaphragm - Metering .....	1	C								
20	*67496	. Gasket - Diaphragm .....	1	C								
21	*67500	. Screw - Lever pin .....	1	C								
22	*67508	. Pin - Lever .....	1	C								
23	*67509	. Lever - Metering .....	1	C								
24	*67503	. Spring - Lever .....	1	C								
25	*67491	. Valve - Needle .....	1	C								
26	67483	. Body Assy - Carburetor .....	1	C								
27	*71690	. Plug - 3/8 .....	1	C								
28	*69506	. Plug - 5/16 .....	1	C								
29	83758	. Seat Assy .....	1	C								
30		. Valve .....	1	C								
31	*67507	. Screen - Fuel .....	1	C								
	*67482	Gasket Set										
	67481	Repair Kit										

\*Indicates parts included in Repair Kit, P/N 67481

**MCCULLOCH SDC-2 CARBURETOR ADJUSTMENT**

- Carefully turn both the high speed and idle needles clockwise until resistance is felt, then turn both needles counterclockwise one full turn.
- With engine warmed up, adjust the idle speed screw in or out until the engine idles just below clutch engagement speed.
- Adjust the idle mixture needle in or out (leaner or richer) to obtain smooth, rapid acceleration every time without faltering. If necessary, readjust the idle speed screw.
- Adjust the high speed mixture needle for maximum power under load. Turn the needle in for leaner and out for richer mixture. Do not use any leaner setting than necessary to obtain smooth, even running when cutting wood.

Wire continuity shown by letters.  
Match A-A, B-B, Etc.

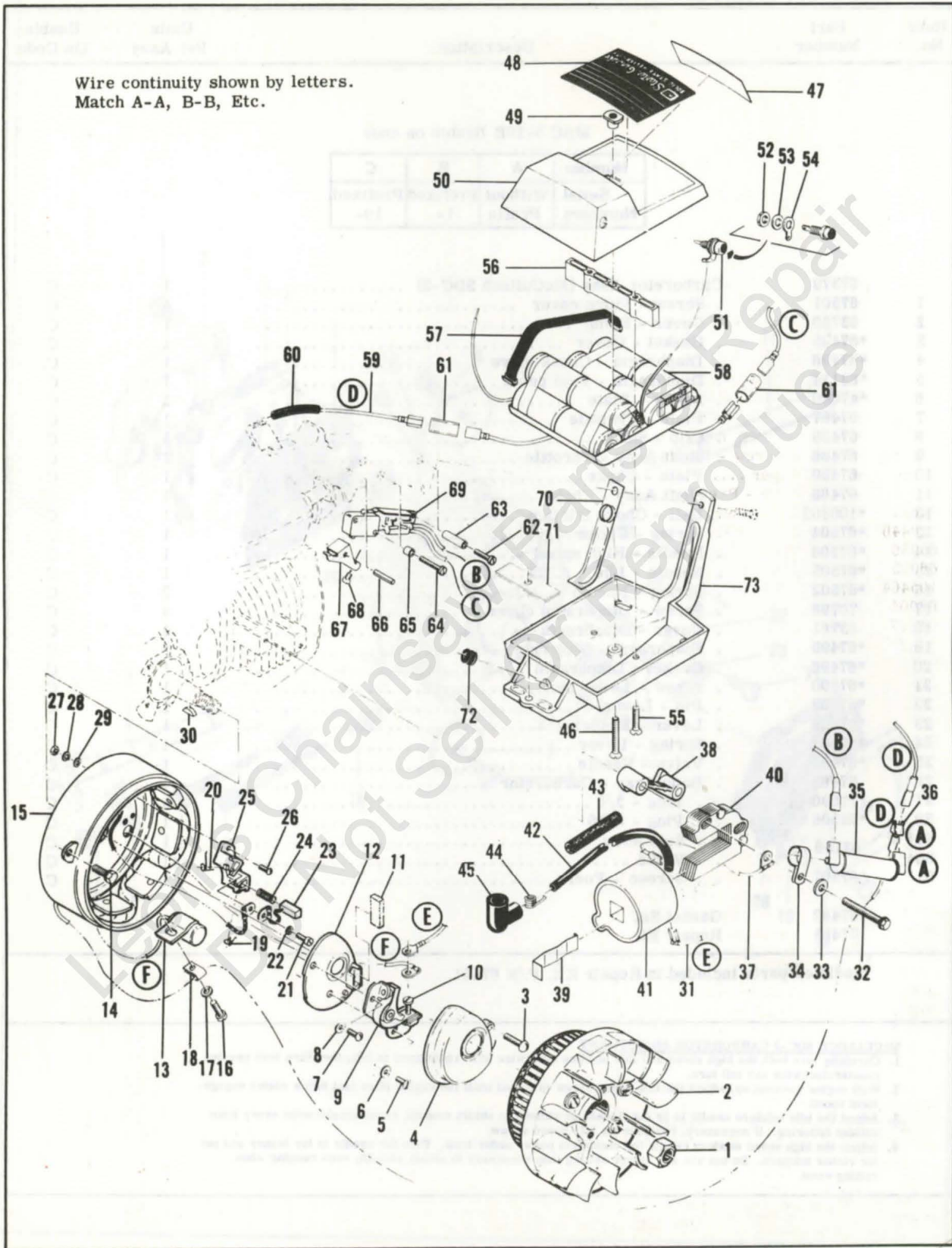

Figure 6. Electrical Components

FIGURE 6. ELECTRICAL COMPONENTS

Item No.	Part Number	Description	Units Per Assy	Usable On Code								
MAC 5-10E Usable on code												
<table border="1"> <thead> <tr> <th>Number</th> <th>A</th> <th>B</th> <th>C</th> </tr> </thead> <tbody> <tr> <td>Serial Numbers</td> <td>Without Prefix</td> <td>Prefixed 1-</td> <td>Prefixed 10-</td> </tr> </tbody> </table>					Number	A	B	C	Serial Numbers	Without Prefix	Prefixed 1-	Prefixed 10-
Number	A	B	C									
Serial Numbers	Without Prefix	Prefixed 1-	Prefixed 10-									
1	101391	Nut - Hex 3/8-24	1	All								
2	65995	Armature & Flywheel Assy	1	All								
3	100690	Screw - Rd hd 8-32 x 1/2	1	All								
4	65415	Top - Breaker box	1	All								
5	110445	Screw - Tr hd 8-32 x 3/8	1	All								
6	105976	Washer - #8	1	All								
7	100934	Screw - Rd hd 8-32 x 3/8	1	All								
8	100080	Washer - #8	1	All								
9	66231	Breaker Assy	1	All								
10	110489	. Screw - Pan hd 6-32 x 7/16	1	All								
11	54184	Wiper	1	All								
12	65414	Base - Breaker points	1	All								
13	64624	Condenser	1	All								
14	110446	Screw - Hex hd 10-24 x 3/4 (SEMS)	2	All								
15	65996	Housing Assy - Field coil	1	All								
16	66005	. Screw - Fil hd 8-32 x 5/16	1	All								
17	105464	. Lockwasher - #8	1	All								
18	66004	. Clamp	1	All								
19	66777	. Spring - Brush clip	1	All								
20	66776	. Spring - Brush clip	1	All								
21	65997	. Screw - Fil hd 5-40 x 1/4	2	All								
22	65998	. Lockwasher - #5	2	All								
23	65999	. Brush	2	All								
24	66003	. Spring - Brush	2	All								
25	66778	. Kit - Brush holder	1	All								
26	66007	. . Screw	2	All								
27	66009	. . Nut	2	All								
28	66008	. . Lockwasher	2	All								
29	66162	. . Washer	2	All								
30	103879	Key - Woodruff	1	All								
31	64609	Wire Assy - Primary	1	All								
32	110450	Screw - Hex hd 10-24 x 1-5/8 (SEMS)	2	All								
33	100003	Washer - #10	2	All								
34	65517	Clamp - Mounting	2	All								
35	65518	Resistor	1	All								
36	110478	Terminal - Wire	1	All								
37	62819	Wire Assy - Ground	1	All								
38	64653	Spacer - Coil	1	All								
39	51253	Retainer - Coil	1	All								
40	85138	Lamination Assy	1	All								
41	84972	Coil & Terminal Assy	1	All								
42	69966	. Wire Assy - Spark plug	1	All								
43	67127	. . Sleeve - Wire Assy	1	All								
44	62932	. . Connector	1	All								
45	62926	. . Boot - Spark plug	1	All								
46	110480	Screw - Fl hd 8-32 x 1-3/8	1	All								
47	65438	Nameplate	1	All								
48	65305	Emblem	1	All								
49	65319	Insert - Cover	1	All								
50	65470	Cover - Battery box	1	All								
51	65567	Phono-Jack	1	All								
52	65876	. Nut	1	All								

FIGURE 6. ELECTRICAL COMPONENTS (CONT.)

Item No.	Part Number	Description	Units Per Assy	Usable On Code
53	65875	. Washer .....	1	All
54	65877	. Terminal .....	1	All
55	100403	Screw - Fl hd 8-32 x 1 .....	2	All
56	66234	Spacer - Battery .....	1	All
57	65501	Strap Assy - Battery .....	2	All
58	66161	Battery Assy .....	1	All
59	65541	Wire Assy - Battery to resistor .....	1	All
60	80975	Sleeve - Wire Assy .....	1	All
61	65306	Sleeve - Wire terminal .....	2	All
62	110462	Screw - Pan hd 4-40 x 11/16 .....	1	All
63	64874	Spacer - Long .....	1	All
64	110463	Screw - Pan hd 4-40 x 13/16 .....	2	All
65	64873	Spacer - Short .....	2	All
66	110451	Pin - Roll .....	1	All
67	64681	Activator .....	1	All
68	110477	Screw - Actuator pan hd 6-32 x 3/16 .....	1	All
69	68145	Switch - Regulator Assy .....	1	All
70	64727	Strip - Handle brace .....	1	All
71	65512	Insulator - Shroud .....	1	All
72	101230	Grommet - Handle brace .....	1	All
73	83120	Brace - Handle .....	1	A
	69920	Brace - Handle .....	1	B,C

Leon's Chainsaw Parts & Repair  
Do Not Sell Or Reproduce



**40:1 TWO-CYCLE MOTOR OIL**

Reduces smoke, carbon and engine wear.



6 oz. can # 78960  
6-pack # 78961  
16 oz. can # 78963  
6-pack # 78964  
1 qt. bottle # 110626

**CHAIN, BAR AND SPROCKET OIL**

Specially designed for extra lubrication of bars and chains.



1 qt. bottle # 110631  
Case of 24 # 110632

**BAR GUARDS**

Protect bar and chain from accidental damage.

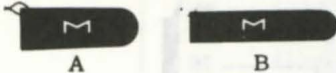

A Black Polyvinylchloride  
B (B) narrow bars # 64930

(A) for wide bars # 56927  
(B) narrow bars # 64930



C Rigid Yellow Plastic  
D (D) PM6-12, 16" # 83124

(C) MAC 10-16, 20" # 66544  
(D) PM6-12, 16" # 83124

**LOCQUIC AND**

Primer. Cleans, degreases, and accelerates curing.



7-1/2 oz. spray can. # 69794

**LOCTITE**

Sealant, bonding agent



10cc plastic bottle # 67537

**SPRAY PAINT**

Black

12 oz. can # 103503  
Case of 12 # 103400



Yellow

12 oz. can # 102449  
Case of 12 # 102464

**STARTER ROPE**

Solid, braided nylon



100' spool # 36825

**CHAIN SHARPENING TOOLS**

The ● shows which tools are used on chains . . . .

		S-25	SM-57	S-40	S-80	S-90
<p><b>McCULLOCH FILES</b></p>	1/8" round	●				
	5/32" round	●				
	3/16" round		●			
	7/32" round			●		
	1/4" round				●	
	9/32" round					●
8" flat	●	●	●	●	●	●
6" flat safety	●	●	●	●	●	●
<p><b>FILE GUIDE &amp; FILE</b></p>	#67750 (1/8" round)	●				
	#60950 (7/32" round)			●		
	(Also holds 3/16 and 1/4" round)			●		
<p><b>DEPTH GAUGE TOOLS</b></p>	#56241 .045-.060"			●	●	●
	#64198 .035-.060"			●	●	●
	#64379 .045-.050"			●	●	●
	#67688 .015-.020"			●	●	●
	#67680 .025-.030"			●	●	●
<p><b>FILE-N-JOINT</b> Assures correct filing angle, height.</p>	#61034	●	●	●	●	●

**"BREAK ALL" CHAIN BREAKER**

Required when repairing chain.

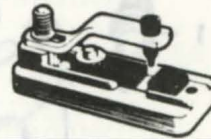

#61753  
Instructions included.

**PRESSURE TEST TOOLS**

For leakage check of crankcase, fuel system.

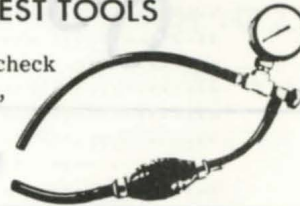

Basic unit # 62849



FIGURE 7. POWERHEAD ASSEMBLY (CONT.)

Item No.	Part Number	Description	Units Per Assy	Usable On Code
6	62266	Plunger - Pump .....	1	All
7	101056	"O" Ring - Plunger .....	1	All
8	66687	Spring - Plunger .....	1	All
9	62230	Gasket - Pump .....	1	All
10	62909	Valve - Pump .....	1	All
11	110291	Screw - Pan hd 10-24 x 2-5/8 .....	1	All
12	63072	Cover - Oil tank .....	1	All
13	62116	Gasket - Cover .....	1	All
14	57129A	Cap - Oil tank .....	1	All
15	101148	"O" Ring - Cap .....	1	All
16	62123B	Hose Assy - Oil .....	1	All
17	51506	Screen - Hose .....	1	All
18	110333	Screw - Oval hd 8-32 x 1/2 .....	3	All
19	62274	Gasket - Pulse pump .....	1	All
20	83786	Pump Assy - Pulse .....	1	All
21	60260A	. Piston Assy - Pump .....	1	All
22	104001	. "O" Ring .....	1	All
23	60263	. Ring - Piston .....	1	All
24	60937	. Washer - Teflon .....	1	All
25	60259	. Spring - Piston .....	1	All
26	62227	. Sleeve - Adjustment .....	1	All
27	110386	. Screw - Hex hd 8-32 x 1 .....	1	All
28	100251	. Nut - Hex 8-32 .....	1	All
29	63858	. Cover Assy - Valve .....	1	All
30	106104	. "O" Ring .....	1	All
31	62885A	. Spring .....	1	All
32	102809	. Ball .....	1	All
33	83787	. Body .....	1	All
34	62065	Bolt - Bar .....	2	All
35	67432	Crankcase Assy .....	1	All
36	62105	. Screw Assy - Sealing .....	4	All
37	62842	. . Washer - Sealing .....	4	All
38	110289	. Screw Assy - 8-32 x 1-1/8 .....	1	All
39	110288	. Screw Assy - 8-32 x 3/4 .....	3	All
40	100010	. Pin - Cotter .....	1	All
41	65910	. Valve - Compression release .....	1	All
42	65389	Pin - Piston .....	1	All
43	85240	Piston Assy .....	1	All
44	63290	. Ring Set - Piston .....	1	All
45	103085	. Bearing .....	2	All
46	65401	Connecting Rod Assy .....	1	All
47	61627A	. Screw - Skt hd 8-36 x 1/2 .....	2	All
48	63225	. Roller - Needle (Set of 20) .....	1	All
49	61618	Oil Seal .....	1	All
50	63464	Ring - Snap .....	1	All
51	63429B	Bearing - Ball .....	1	All
52	110260	Oil Seal .....	1	All
53	104357	Bearing - Needle .....	1	All
54	85125	Crankshaft .....	1	All
55	63699	Ring - Bearing insert .....	1	All
56	63701	Insert - Bearing .....	1	All

The information contained in this Master Illustrated Parts List is based on original Illustrated Parts Lists, Engineering Records and the Master Parts Price List and is accurate to the best of our knowledge.

Each chain saw model is given a code letter. Whenever the code letter appears in the right hand column, the part is used on the engines of the model for which the code letter stands. When a part is used on all models covered in the Master Illustrated Parts List, the word "All" appears in the right-hand column instead of the code letters.

Names of parts have been checked and made to agree with the names given in the Master Parts Price List except in a very few cases where additional nomenclature was required.

The illustrations of the individual parts do not necessarily picture all the differences between parts with the same item number because the illustrations would be too complicated for use if they did. Instead, the illustration shows a representative part for each item number.

 **McCULLOCH**



● **MANUFACTURING** ●

**SALES** ●

● **SERVICE** ●

**McCULLOCH CORPORATION**

6101 WEST CENTURY BLVD., LOS ANGELES, CALIFORNIA 90045

**INTERNATIONAL DIVISIONS:**

LOS ANGELES, CALIF., P.O. BOX 45466

BUENOS AIRES, ARGENTINA: CASILLA DE CORREO 2467

SINGAPORE, 431-432 PEOPLE'S PARK COMPLEX

**McCULLOCH OF CANADA LTD.**

6338 VISCOUNT ROAD, MALTON, ONTARIO, CANADA

**McCULLOCH OF EUROPE, N. V.**

ANTOON SPINOYSTRAAT, 5, B-2800 MECHELEN, BELGIUM

**McCULLOCH OF AUSTRALIA PTY., LTD.**

P.O. BOX 223, SEVEN HILLS, N.S.W. 2147, AUSTRALIA