

ILLUSTRATED PARTS LIST

This Master Illustrated Parts List gives the name, number and interchangeability between engines, of service and replacement parts which were used on or are presently available for installation on the listed chain saw models.

Information about the List and how to use it will be found on the back cover. Read the information before you start to use the List.

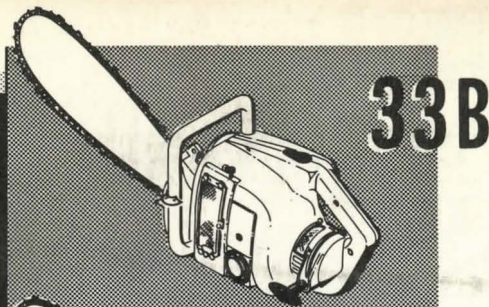

33B

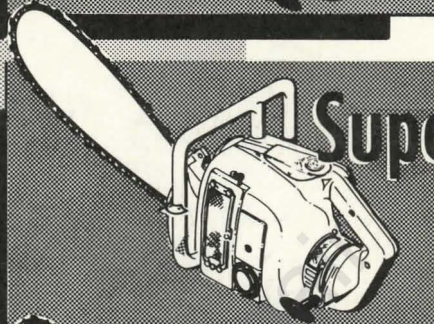

Super 33

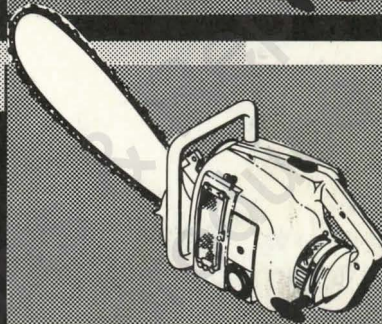

35

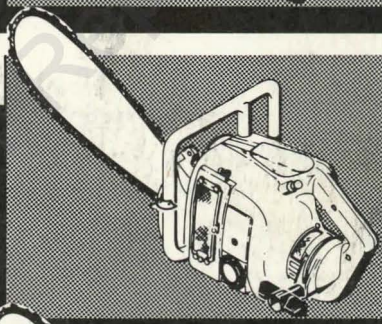

39

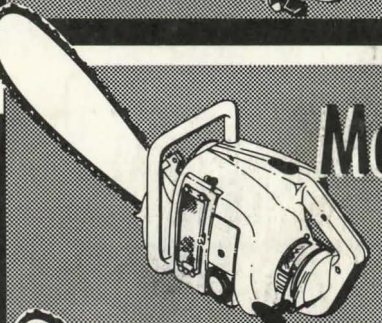

Mac 35

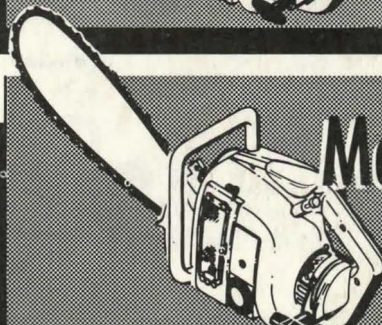

Mac 35A



No. 56774

McCULLOCH CORPORATION
Los Angeles 45, California

33 SERIES ENGINES

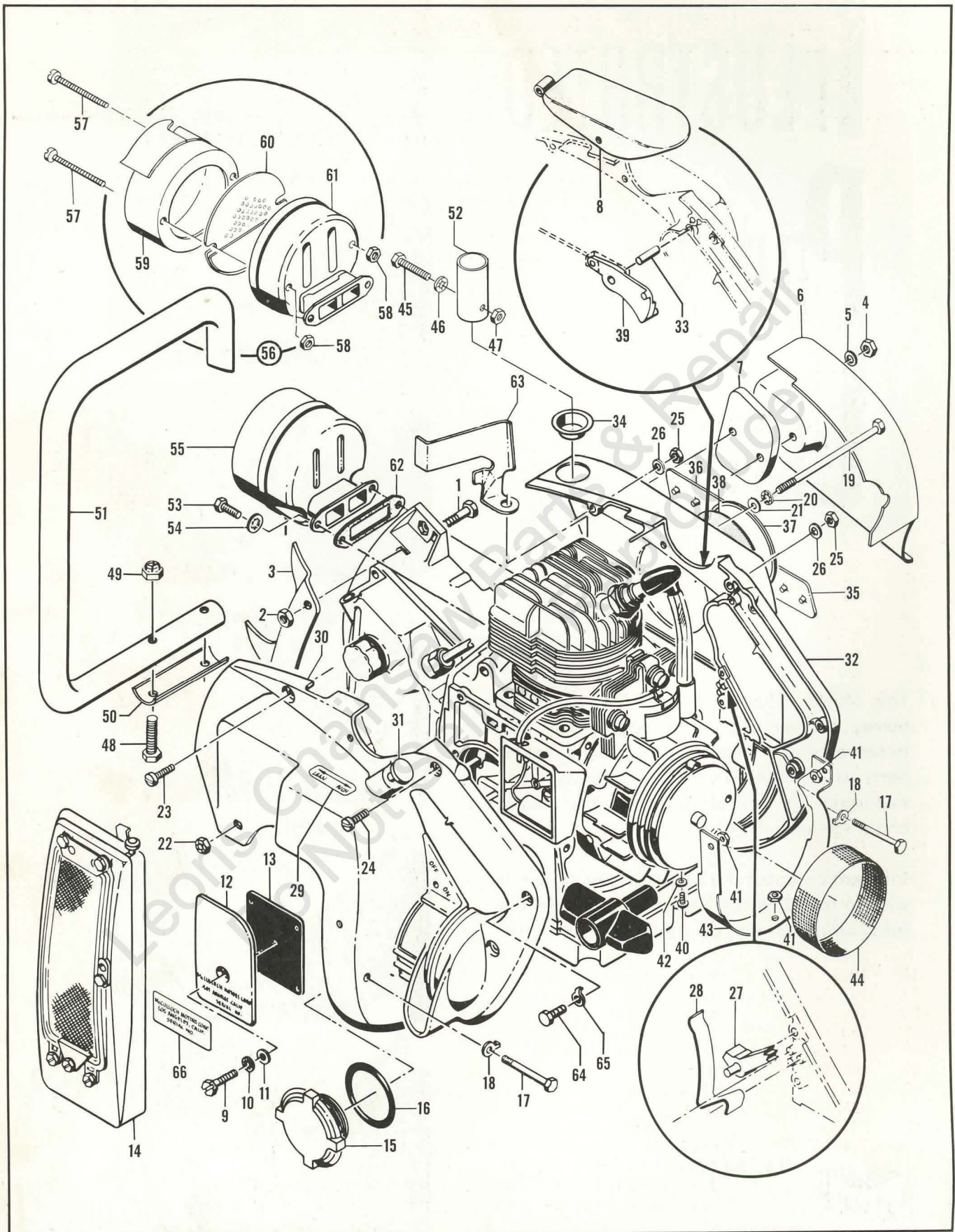

Figure 1. Fan Housings, Muffler and Access Covers

FIGURE 1. FAN HOUSINGS, MUFFLER AND ACCESS COVERS

FIG. & INDEX NO.	PART NO.	DESCRIPTION	UNITS PER ASSY	USABLE ON CODE
		1 2 3 4 5 6 7		
Code: "A" indicates parts used on Model 33B engines.				
"B" indicates parts used on Model Super 33 engines.				
"C" indicates parts used on Model 35 engines.				
"D" indicates parts used on Model 39 engines.				
"E" indicates parts used on Model MAC 35 engines.				
"F" indicates parts used on Model MAC 35A engines.				
"All" indicates parts used on all six listed engines.				
1-1	100732	Screw - Hex hd 1/4-20 x 5/8 in. lg.	2	All
-2	101143	Nut - Hex 1/4-20	2	
-3	36492	Spike - Bucking	1	A, B, C, D
	52415	Spike	1	E, F
-4	103727	Nut - Guide hex 5/16-24	2	A, B, C, D
	103729	Nut - Hex 3/8-24	2	E, F
-5	100440	Washer - 5/16 in.	2	A, B, C, D
	100006	Washer	2	E, F
-6	52294	Cover - Chain guard	1	B, D
-7	36105A	Clamp Plate	1	A, B, C
	52289	Clamp Plate - Bar	1	D, E, F
-8	36149	Cover Assy - Spark plug	1	A, C, E
	36548	Cover - Spark plug	1	B
	*52288A	Cover - Spark plug	1	D, F
-9	102760	Screw - Hex hd 10-24 x 1 in. lg.	1	All
-10	101194	Lockwasher - No. 10	1	All
-11	102189	Washer	1	All
-12	36011	Cover - Breaker box	1	All
-13	36013	Gasket - Breaker box	1	All
-14		Carburator and Air Filter (See figure 2)	1	All
	36202	Fuel Cap Assembly	1	A, B, C, E, F
		Fuel Cap Assembly (Not available as an assembly - Order individual parts)	1	D
-15	36200	Fuel Cap	1	A, B, C, E, F
	52231	Fuel Cap	1	D
-16	101348	"O" Ring	1	A, B, C, E, F
	103813	"O" Ring - Fuel cap	1	D
-17	102125	Screw - Hex hd 1/4-20 x 1-3/4 in. lg.	2	All
-18	36306	Lockplate	2	All
-19	102131	Bolt - Hex hd 1/4-20 x 4-1/2 in. lg.	1	All
-20	102543	Lockwasher	1	A, B
-21	100440	Washer - 5/16 in.	1	A
	100004	Washer - Plain 1/4 in.	1	B, D
	100311	Washer - Plain 1/4 in. SAE	1	C, E, F
-22	101143	Nut - Hex 1/4-20	1	All
-23	102145	Screw - Fil hd 10-24 x 1-1/4 in. lg.	1	All
-24	102143	Screw - Fil hd 10-24 x 3/4 in. lg.	5	All
-25	101191	Nut - Hex 10-24	6	All
-26	102189	Washer	6	All
-27	36378	Toggle - Ground switch	1	All
-28	36411A	Spring - Ground switch	1	All
-29	36473	Decal	1	E, F
-30	52607	Fan Housing - LH	1	A, B, C, E, F
	52321	Housing - Fan LH	1	D
-31	52256	Oiler Rod Assembly	1	D, F
-32	36481A	Fan Housing Assembly - RH (Not available - Order Fan Housing Assembly #52608)	1	A
	36568A	Housing - Fan RH (Not available - Order Fan Housing #52295A)..	1	B
	52362	Fan Housing Assembly - RH (Not available - Order Fan Housing Assembly #52608)	1	C, E

*Must be used with #52607 LH Fan Housing and #52608 RH Fan Housing Assembly.

33 SERIES ENGINES

FIGURE 1. (CONT)

FIG. & INDEX NO.	PART NO.	DESCRIPTION	UNITS PER ASSY	USABLE ON CODE
		1 2 3 4 5 6 7		
1-	52295A	Housing - Fan RH	1	D
-33	103699	. Shaft	1	C,E,F
-34	36333	. Bushing - Fan housing	1	B,C,E,F
-35	36551	. Emblem - "Super"	1	B
-36	36549	. Emblem - "33"	1	B
-37	28084	. Medallion	1	A
	36624	. Medallion	1	B
-38	28090	. Adhesive - Plastic	1	A,B
Replacement R.H. Fan Housing Assembly #52608				
	52608	Fan Housing Assembly - RH	1	A,C,E,F
-33	103699	. Shaft	1	A,C,E,F
-34	36333	. Bushing - Fan housing	1	A,C,E,F
-37	28084	. Medallion	1	A,C,E,F
-39	36374A	Trigger Assembly	1	A,B,D,E,F
-40	*100934	Screw - Round hd 8-32 x 3/8 in. lg.	3	A,B
-41	*100955	Nut - Hex 8-32	3	A,B
-42	*100080	Washer - Plain	1	A,B
-43	*36251	Scroll - Fan housing	1	A,B
-44	36060	Screen - Sawdust	1	All
	36874	Screen - Sawdust (fine mesh) Alternate.	1	All
-45	103278	Bolt - Hex 1/4-28 x 1/2 in. lg.	1	B
	100822	Screw - Hex hd 1/4-20 x 1-1/4 in. lg.	1	D
-46	100246	Lockwasher	1	B
-47	101143	Nut - Hex 1/4-20	1	D
-48	102130	Screw - Hex hd 1/4-20 x 1-1/2 in. lg.	2	All
-49	101143	Nut - Hex 1/4-20	2	All
-50	52411	Plate - Reinforcement	1	E,F
-51	36168	Handle Assembly	1	A,C,E,F
	36606A	Handle - Saw	1	B,D
-52	36563	Sleeve - Handle	1	B,D
-53	102388	Screw - Hex hd 10-24 x 5/8 in. lg.	2	All
-54	103100	Lockwasher	2	All
-55	36552	Muffler	1	A,B,D,F
	52366	Muffler	1	C,E
Spark Arrestor Muffler Assembly #52487				
-56	52487	Muffler Assembly	1	All
-57	103363	. Screw - Hex hd 10-24 x 2-1/8 in. lg.	2	All
-58	101191	. Nut - Hex 10-24	2	All
-59	52425	. Top Assembly - Muffler	1	All
-60	51968	. Baffle Assembly - Muffler	1	All
-61	52424	. Bottom Assembly - Muffler	1	All
-62	36093	Gasket - Exhaust	1	All
-63	36532A	Air Baffle - Cylinder	1	All
-64	102388	Screw - Hex hd 10-24 x 5/8 in. lg.	3	All
-65	28052A	Lockplate	3	All
-66	36468	Name Plate	1	A,C

*These parts are not necessary and can be discarded. Plug screw holes in housing with rivets.

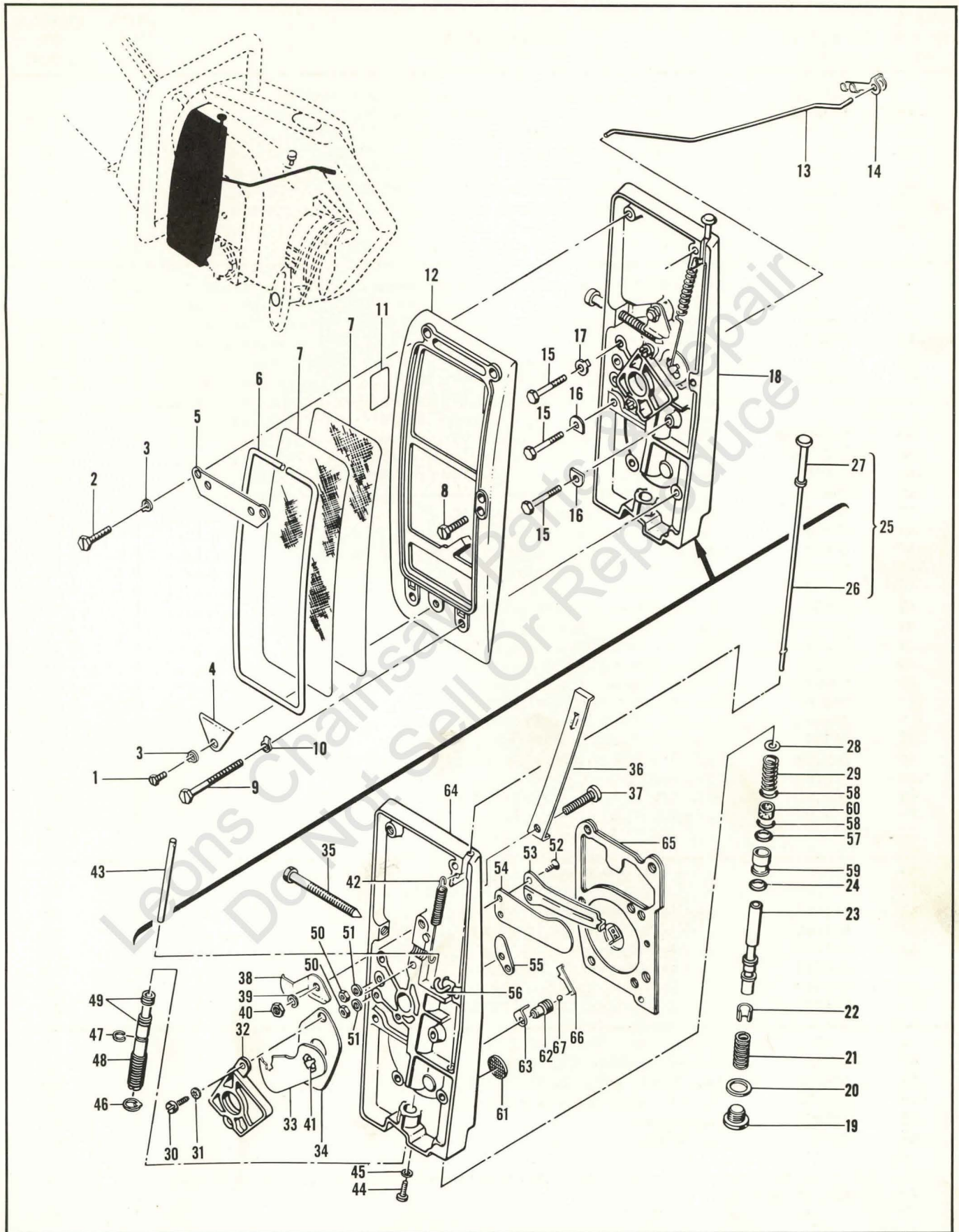

Figure 2. Carburetor and Air Filter

33 SERIES ENGINES

FIGURE 2. CARBURETOR AND AIR FILTER

FIG. & INDEX NO.	PART NO.	DESCRIPTION							UNITS PER ASSY	USABLE ON CODE
		1	2	3	4	5	6	7		
2-1	103469								1	All
-2	102761								2	All
-3	28052								3	All
-4	36424								1	All
-5	36425								1	All
-6	36426								1	All
-7	36427								2	All
-8	102765								1	All
-9	102586								2	All
-10	28052								3	All
-11	36495								1	All
-12	36382A								1	All
-13	36409								1	All
-14	36496								1	All
-15	102760								3	All
-16	36388								2	All
-17	28052								1	All
-18	36621A								1	All
-19	36445								1	All
-20	36446								1	All
-21	11086								1	All
-22	24104								1	All
-23	36140								1	All
-24	101056								1	All
-25	36198								1	All
-26	36199								1	All
-27	36197								1	All
-28	102206								1	All
-29	28754								1	All
-30	101991								2	All
-31	101194								2	All
-32	36117								1	All
-33	36116								1	All
-34	52082								1	All
-35	102687								1	All
-36	36356								1	All
-37	101904								1	All
-38	36494								1	All
-39	100240								1	All
-40	100239								1	All
	101191								1	All
-41	36255								1	All
-42	52421								1	All
-43	*36618								1	All
-44	102500								1	All
-45	100002								1	All
-46	36132								1	All
-47	103251								1	All
-48	*36620								1	All
									2	All
-49	101258								2	All
-50	100796								2	All

Code: "A" indicates parts used on Model 33B engines.
 "B" indicates parts used on Model Super 33 engines.
 "C" indicates parts used on Model 35 engines.
 "D" indicates parts used on Model 39 engines.
 "E" indicates parts used on Model MAC 35 engines.
 "F" indicates parts used on Model MAC 35A engines.
 "All" indicates parts used on all six listed engines.

*Contained in Needle Sleeve Kit #52619.

FIGURE 2. (CONT)

FIG. & INDEX NO.	PART NO.	DESCRIPTION							UNITS PER ASSY	USABLE ON CODE
		1	2	3	4	5	6	7		
2-51	100296	.							2	All
-52	102834	.							2	All
-53	36114A	.							1	All
-54	36115A	.							1	All
	36628A	.							1	All
-55	36109A	.	.						1	All
-56	36108	.	.						1	All
-57	101056	.	.						1	All
-58	36625	.	.						2	All
-59	36150	.	.						1	All
-60	21112	.	.						1	All
-61	36447	.	.						1	All
-62	28737	.	.						1	All
-63	19625	.	.						1	All
-64		.	.						1	All
									1	All
-65	36696B	.							1	All
-66	19626	.							1	All
-67	100302	.							1	All

FIGURE 3. STARTER, FLYWHEEL AND IGNITION SYSTEM

FIG. & INDEX NO.	PART NO.	DESCRIPTION							UNITS PER ASSY	USABLE ON CODE
		1	2	3	4	5	6	7		
Code: "A" indicates parts used on Model 33B engines.										
"B" indicates parts used on Model Super 33 engines.										
"C" indicates parts used on Model 35 engines.										
"D" indicates parts used on Model 39 engines.										
"E" indicates parts used on Model MAC 35 engines.										
"F" indicates parts used on Model MAC 35A engines.										
"All" indicates parts used on all six listed engines.										
3-1	36059	.							1	All
-2	36451A	.							1	A, B
	36451B	.							1	C, D, E, F
-3	36087	.							1	A, B
-4		.							1	C, D, E, F
-5	18840A	.							1	A, B
-6	36395	.							1	A, B
-7	101871	.							1	A, B
-8	24818	.							1	C, D, E, F
-9	18849B	.							1	A, B
	24822	.							1	C, D, E, F
-10	36088	.							1	A, B
	36840	.							1	C, D, E, F
-11	19401	.							1	A, B
-12	103697	.							1	C, D, E, F
-13	*36056	.							1	A, B
	36856	.							1	C, D, E, F
-14	36058	.							1	All
-15	36053A	.							1	All
-16	36055	.							1	All
-17	101179	.							1	All
-18	101270	.							1	All

*When replacement Starter Drum #36856, is ordered, one of each of the following must also be ordered: Rope Assembly #36840, Starter Handle #24822, Starter Handle Cup #24818, and rivet #103697.

33 SERIES ENGINES

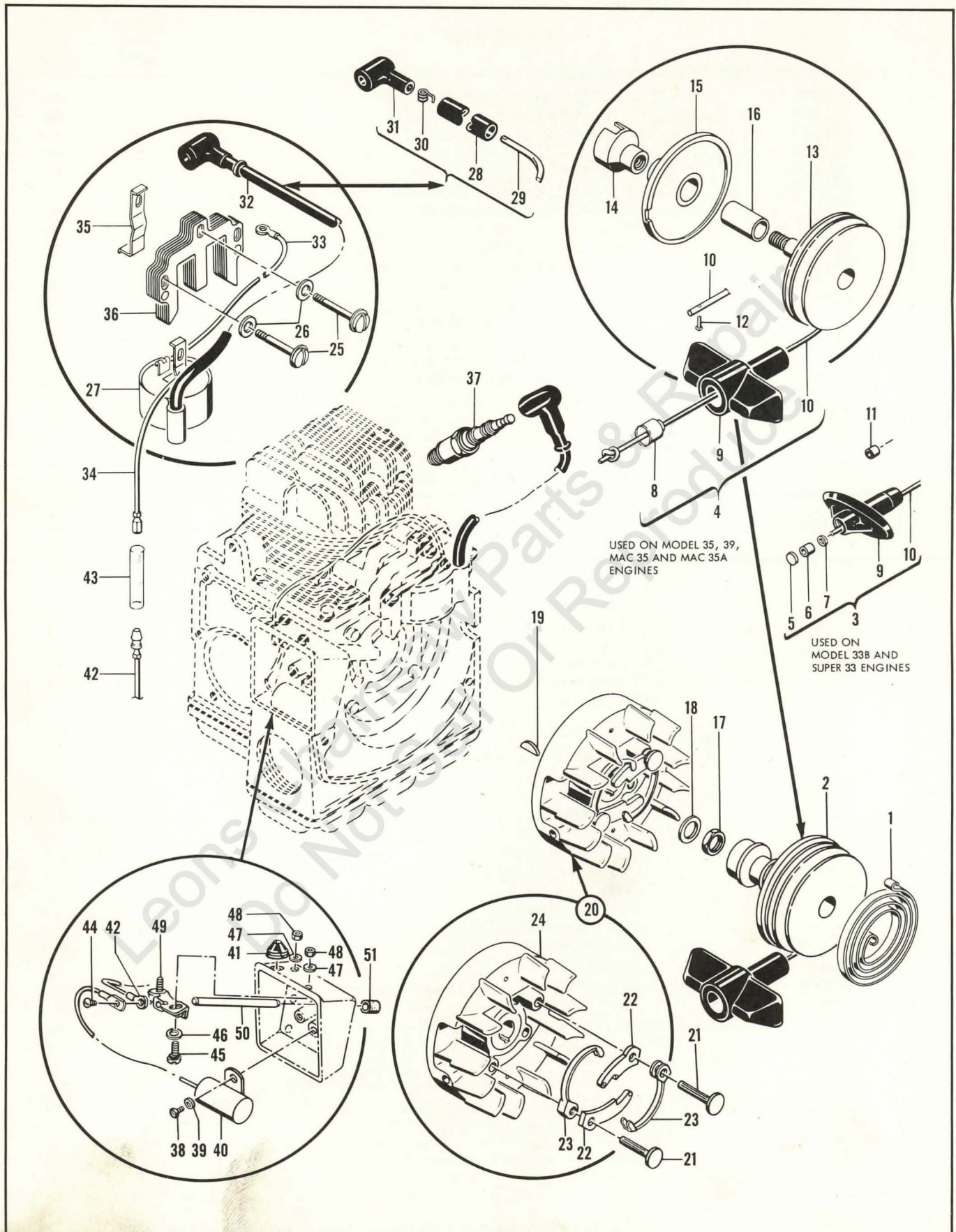

Figure 3. Starter, Flywheel and Ignition System

FIGURE 3. (CONT)

FIG. & INDEX NO.	PART NO.	DESCRIPTION	UNITS PER ASSY	USABLE ON CODE
		1 2 3 4 5 6 7		
3-19	100199	Key - Woodruff No. 404	1	All
-20	36396	Flywheel and Pawl Assembly	1	All
-21	36144	. Pin - Starter pawl	2	All
-22	24093	. Pawl - Starter	2	All
-23	24119	. Spring - Pawl	2	All
-24		. Flywheel Assembly (Not available - Order Flywheel and Pawl Assembly #36396).....	1	All
-25	101965	Screw - Fil hd 10-24 x 7/8 in. lg.	3	All
-26	100003	Washer - Plain No. 10	3	All
-27	36146A	Coil and Terminal Assembly (Not available - Order Coil and Terminal Assembly #36146C)	1	A,B,E
	52390	Coil and Terminal Assembly (Not available - Order Coil and Terminal Assembly #36146C)	1	C
	36146B	Coil and Terminal Assembly (Not available - Order Coil and Terminal Assembly #36146C)	1	D,F
-28	*102534	. Sleeve - Spark plug wire	1	A,B
-29	*102553	. Wire - Spark plug	1	A
	*102839	. Wire - Spark plug	1	B
-30	*102556	. Spark Plug Spring Connector	1	A,B
-31	*102555	. Spark Plug Cover	1	A,B
-32	52547	. Wire Assembly - Spark plug	1	C,D,E,F
-33	101883	. Wire - Ground	1	C,D,E,F
-34	52064	. Wire Assembly - Terminal	1	D,E,F
Replacement Coil and Terminal Assembly #36146C				
-27	36146C	Coil and Terminal Assembly	1	All
-32	52547	. Wire Assembly - Spark plug	1	All
-33	101883	. Wire - Ground	1	All
-34	52064	. Wire Assembly - Terminal	1	All
-35	19034	Retainer - Lamination	2	All
-36	36082	Lamination Assembly	1	All
-37		Spark Plug and Gasket - 14 mm	1	All
-38	100362	Screw - Fil hd mach 8-32 x 3/8 in. lg.	1	All
-39	100057	Lockwasher - No. 8	1	All
-40	100075	Condenser	1	All
-41	28322	Grommet - Rubber	1	All
-42	36483	Wire - Primary	1	A,B
	52064	Ground Wire Assembly	1	D
	52065	Ground Wire Assembly	1	F
-43	52066	Sleeve	1	D,F
-44	103934	Screw - Rd hd 6-32 x 1/4 in. lg.	2	All
-45	24626	Screw	1	All
-46	100007	Washer	1	All
-47	100003	Washer - Plain No. 10	3	All
-48	101191	Nut - Hex 10-24	2	All
-49	19894A	Breaker Point Assembly	1	All
-50	36012	Push Rod - Breaker	1	All
-51	24321A	Washer - Felt	1	All

*These individual parts can be ordered as Spark Plug Wire Assembly #52547, usable on all listed Coil and Terminal Assemblies.

33 SERIES ENGINES

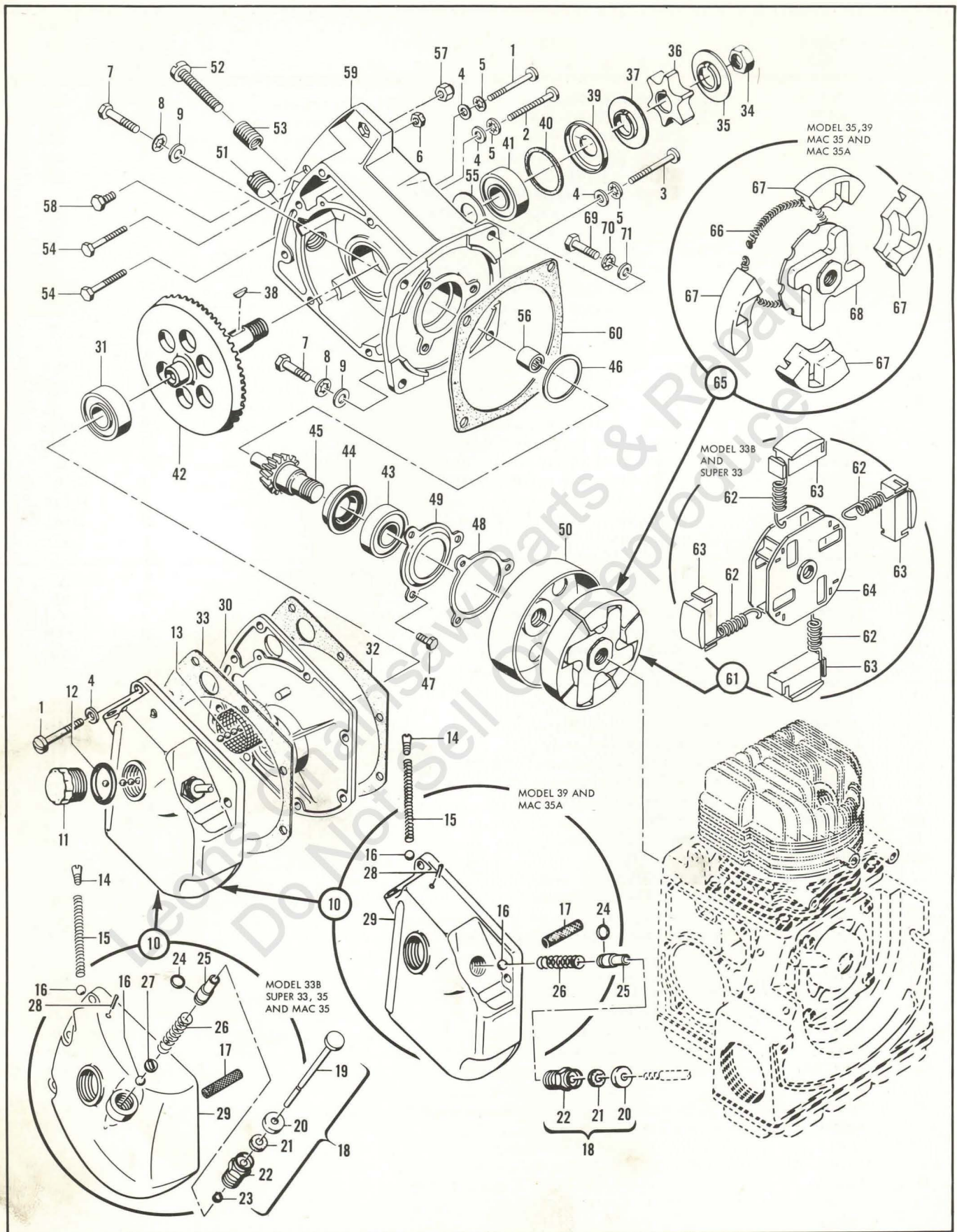

Figure 4. Clutch and Transmission

FIGURE 4. CLUTCH AND TRANSMISSION

FIG. & INDEX NO.	PART NO.	DESCRIPTION	UNITS PER ASSY	USABLE ON CODE
		1 2 3 4 5 6 7		
Code: "A" indicates parts used on Model 33B engines.				
"B" indicates parts used on Model Super 33 engines.				
"C" indicates parts used on Model 35 engines.				
"D" indicates parts used on Model 39 engines.				
"E" indicates parts used on Model MAC 35 engines.				
"F" indicates parts used on Model MAC 35A engines.				
"All" indicates parts used on all six listed engines.				
4-	36094C	Transmission Assembly (Not available - Order Transmission Assembly #36094D)	1	A
	36570	Transmission Assembly (Not available - Order Transmission Assembly #36570C)	1	B
	52355	Transmission Assembly	1	C,E
	52254	Transmission Assembly	1	D
	52593	Transmission Assembly	1	F
-1	102205	. Screw - Fil hd 10-24 x 1-3/8 in. lg.	6	All
-2	102205	. Screw - Fil hd 10-24 x 1-3/8 in. lg.	1	A,C,E,F
	102135	. Screw - Fil hd 10-24 x 2 in. lg.	1	B,D
-3	102205	. Screw - Fil hd 10-24 x 1-3/8 in. lg.	1	A,C,E,F
	102135	. Screw - Fil hd 10-24 x 2 in. lg.	1	B
	102765	. Screw - Hex hd 10-24 x 1-3/4 in. lg.	1	D
-4	102189	. Washer - Plain No. 10	8	All
-5	101194	. Lockwasher - No. 10	5	All
-6	101191	. Nut - Hex 10-24	3	All
-7	101982	. Screw - Hex hd 1/4-20 x 1 in. lg.	2	All
-8	100153	. Lockwasher - 1/4 in.	2	All
-9	100004	. Washer - Plain 1/4 in.	2	All
-10	36124	. Tank Assembly - Oiler (Not available - Order Tank Assembly #52358)	1	A,B
	52358	. Tank Assembly - Oiler	1	C,E
	52291	. Tank Assembly - Oiler	1	D,F
-11	28032	. Oil Filler Cap (Not available - Order Oil Filler Cap #52388)	1	A,B
	52388	. Cap - Oil filler	1	C,D,E,F
-12	101148	. "O" Ring	1	All
-13	36283	. Screen and Chain Assembly (Not required when Oil Filler Cap #52388 is used)	1	A,B
-14	101864	. Pipe Plug	1	All
-15	36101	. Spring - Discharge	1	A,B,C,E
	36421	. Spring - Discharge	1	D,F
-16	100549	. Ball	2	All
-17	36166	. Screen - Intake	1	A,B,C,E
	52276	. Screen - Intake	1	D,F
-18	36172	. Plunger and Plug Assembly	1	A,B,C,E
	52297	. Plug and Seal Assembly	1	D,F
-19	36127	. Plunger Assembly	1	A,B,C,E
-20	36165	. Seal Cap	1	All
-21	36164	. Seal - Felt	1	A,B,C,E
	36420	. Seal - Felt	1	D,F
-22	36163	. Plug - Plunger	1	All
-23	102189	. Washer	1	A,B,C,E
-24	101056	. "O" Ring	1	A,B,C,D,E
	101048	. Packing - "O" ring	1	F
-25	36126	. Piston - Chain oiler pump	1	All
-26	*19236	. Spring	1	A,B,C,D,E
	36421	. Spring - Discharge	1	F
-27	*36161	. Check Valve Retainer	1	A,B,C,D,E
-28	100010	. Cotter Pin - 0.06 dia x 1/2 in. lg.	1	All
-29	36125	. Tank - Oiler	1	A,B,C,E
	52275	. Tank - Oiler	1	D,F

*These two parts can be replaced with Discharge Spring #36421.

33 SERIES ENGINES

FIGURE 4. (CONT)

FIG. & INDEX NO.	PART NO.	DESCRIPTION							UNITS PER ASSY	USABLE ON CODE
		1	2	3	4	5	6	7		
4-	36154B	1	All
-30	36136B	1	All
-31	103482	1	All
-32	52323	As Req'd	All
	52323A	As Req'd	All
	52323B	As Req'd	All
-33	52323B	1	All
-34	100836	1	All
-35	36019A	1	A,B
	36862	1	C,D,E,F
-36		1	All
-37	36019A	1	All
-38	100256	1	All
-39	19162	1	All
-40	36155	1	All
-41	102187	1	A,B
	103482	1	C,D,E,F
-42	36047B	1	A,C,E,F
	36543	1	B,D
-43	102187	1	A
	103159	1	B,D
	103482	1	C,E,F
-44	36159	1	A,C,E,F
	103084	1	B,D
-45	36048	1	A,C,E,F
	36544	1	B,D
-46	36160C	As Req'd	A,C,E,F
	36160A	As Req'd	A,C,E,F
	36160B	As Req'd	A,C,E,F
	36793A	As Req'd	B,D
	36793B	As Req'd	B,D
	36793C	As Req'd	B,D
-47	102762	3	All
-48	36301	1	All
-49	36138	1	All
-50	52341	1	All
	36095A	1	A
	36571A	1	B
	52356	1	C,E,F
	52255	1	D
-51	104218	1	All
-52	36151B	1	All
-53	103747	1	D
-54	103726	2	A,B
	52111	2	C
	52208	2	D,E,F
-55	102577	1	All
-56	102186	1	A,C,E,F
	103085	1	B,D
-57	101143	1	E,F
-58	100732	1	E,F
-59	52357	1	A,C,E,F
	52204	1	B,D

FIGURE 4. (CONT)

FIG. & INDEX NO.	PART NO.	1	2	3	4	5	6	7	UNITS PER ASSY	USABLE ON CODE
Replacement Gear Case Assemblies #36095D and #36571C										
4-	36095D	.							1	A
	36571C	.							1	B
-51	104218	.	.						1	All
-52	36151B	.	.						1	All
-53	103747	.	.						1	B
-54	52111	.	.						2	A,B
-55	102577	.	.						1	All
-56	102186	.	.						1	A
	103085	.	.						1	B
-57	101143	.	.						1	A,B
-58	100732	.	.						1	A,B
		.	.						1	A
-59	52357	.	.						1	A
	52204	.	.						1	B
-60	36623	.							1	All
-61	36092	.							1	A,B
-62	19124A	.							4	A,B
-63	36033	.							4	A,B
-64	36029	.							1	A,B
-65	52067A	.							1	C,D,E,F
-66	51468	.							1	C,D,E,F
-67	51464A	.							4	C,D,E,F
-68	52062A	.							1	C,D,E,F
-69	101982	.							2	All
-70	100153	.							2	All
-71	100004	.							2	All

FIGURE 5. CRANKCASE, CRANKSHAFT, CYLINDER AND PISTON

FIG. & INDEX NO.	PART NO.	1	2	3	4	5	6	7	UNITS PER ASSY	USABLE ON CODE
Code: "A" indicates parts used on Model 33B engines.										
"B" indicates parts used on Model Super 33 engines.										
"C" indicates parts used on Model 35 engines.										
"D" indicates parts used on Model 39 engines.										
"E" indicates parts used on Model MAC 35 engines.										
"F" indicates parts used on Model MAC 35A engines.										
"All" indicates parts used on all six listed engines.										
5-1	101885	.							4	All
-2	100311	.							4	All
-3	18556A	.							4	All
-4	100640	.							4	All
-5	36442	.							1	All
-6	36617A	.							1	B
	52328	.							1	D
		.							1	A,C,E,F
-7	102660	.							6	All
-8	101191	.							6	All
-9	24236	.							6	All
-10	36470A	.							1	A,C,E,F
	52223	.							1	B,D
-11	52222	.							1	All

33 SERIES ENGINES

FIGURE 5. (CONT)

FIG. & INDEX NO.	PART NO.	DESCRIPTION	UNITS PER ASSY	USABLE ON CODE
		1 2 3 4 5 6 7		
5-12	36466A	. Cylinder	1	A, C, E, F
	52224	. Cylinder	1	B, D
	36531	Piston Assembly - Std (Not available - Order Piston Assembly #52379)	1	A
	36616C	Piston Assembly - Std (Piston Assembly #52045 can also be used on this model. *)	1	B
	52379	Piston Assembly - Std	1	C, E, F
	52045	Piston Assembly - Std	1	D
-13	36678	. Ring Set - Std piston three	1	A, B
	52046	. Ring Set - Std piston two	1	C, D, E, F
-14	36097	. Ring - Retainer	2	A, B, C, E, F
-15	103707	. Bearing - Needle	2	D
-16		. Piston (Not available - Order correct Piston Assembly) ...	1	All
-17	36227	Washer - Special	2	A, B, C, E, F
	*52039	Washer	2	D
-18	20014	Pin - Piston	1	A, B, C, E, F
	*52040	Pin - Piston	1	D
-19	36575A	Connecting Rod Assembly	1	A, B, C, E, F
	*52044	Connecting Rod Assembly	1	D
-20	101356	. Screw - Socket hd 10-32 x 5/8 in. lg.	2	All
-21	102742	. Roller - Needle	22	All
-22	36014A	. Bushing - Wrist pin	1	A, B, C, E, F
-23		. Connecting Rod (Not available - Order correct Connecting Rod Assembly)	1	All
-24	102388	Screw - Hex hd 10-24 x 5/8 in. lg.	4	All
-25	28052	Lock Plate	4	All
-26	101326	Nut - Hex 10-24	2	All
-27	36027A	End Cover Assembly	1	All
-28	102940	. Oil Seal	1	All
-29	36302	. Cam Oil Felt	1	All
-30	36017A	. End Cover	1	All
-31	36028	Gasket - End cover	1	All
-32	100824	Ball Bearing	2	All
-33	36025A	Crankshaft	1	A, B, C, E, F
	52274	Crankshaft	1	D
	36457A	Crankcase Assembly	1	A, B
		Crankcase Assembly (Not available - Order individual parts of assembly)	1	C, E, F
	52320	Crankcase Assembly	1	D
-34	52202A	. Tank - Fuel (top)	1	D
-35	52219A	. Gasket - Fuel pump	1	D
-36	102940	. Oil Seal	1	All
-37	36071	. Deflector - Heat	1	A, B, D
-38	100852	. Screw - Flat hd 10-24 x 1/2 in. lg.	3	All
-39	36010	. Breaker Box	1	All
-40	28322	. Grommet - Rubber	1	D
-41	103464	. Screw - Hex hd 10-24 x 3/4 in. lg.	11	A, B, C, E, F
-42	36079	. Bottom - Fuel tank	1	A, B, C, E, F
-43	36080A	. Gasket - Fuel tank	1	A, B, C, E, F
-44	103815	. Screw - Hex hd 10-24 x 7/8 in. lg.	10	D
-45	103814	. Screw - Hex hd 10-24 x 5/8 in. lg.	2	D
-46	101326	. Nut - Hex 10-24	1	D
-47	52203A	. Bottom - Fuel tank	1	D
-48	52221	. Gasket - Bottom	1	D
-49	36240A	. Spring - Wick retaining	1	A, B, C, E, F
	52278	. Spring - Wick retaining	1	D
-50	36239	. Cap - Wick retaining	1	All
-51	36256	. Fuel Tank Wick	1	A, B, C, E, F
	52226	. Wick	1	D

*When Piston Assembly #52045 is used on Model Super 33 engines, #52044 Connecting Rod, #52039 Washer and #52040 Piston Pin must also be used.

FIGURE 5. (CONT)

FIG. & INDEX NO.	PART NO.	DESCRIPTION							UNITS PER ASSY	USABLE ON CODE
		1	2	3	4	5	6	7		
5-52	36474	.							1	All
-53	102101	.							4	A, B, C, E, F
	102760	.							4	D
-54	28210	.							2	All
-55	36234	.							1	All
-56	36338A	.							1	All
-57	36233	.							1	All
-58	36235A	.							1	All
-59	36237A	.							1	A, B, D
-60	36289A	.							1	A, B
	52318	.							1	C, E, F
	52319	.							1	D

The information contained in this Master Illustrated Parts List is based on original Illustrated Parts Lists, Engineering Records and the Master Parts Price List and is accurate to the best of our knowledge. Additions and changes will be covered in special lists to be issued periodically to distributors and dealers. The Master Illustrated Parts List will be revised and reissued annually if necessary.

This Master Illustrated Parts List carries all the available parts for servicing and repairing the listed chain saw engines. When assemblies are no longer sold but parts are available for repair of the assemblies, the individual parts are listed under the no-longer available assembly and the replacement assembly is carried in parenthesis directly after the name of the part. Replacement assemblies when used in the production of other models appear in sequence in the various lists. When the replacement assembly was not used in the production of other models, the replacement assembly and its parts are boxed.

Each chain saw model is given a code letter. Whenever the code letter appears in the right hand column, the part is used on the engines of the model for which the code letter stands. When a part is used on all models covered in the Master Illustrated Parts List, the word "All" appears in the right-hand column instead of the code letters. When a model uses two different assemblies to do the same thing, earlier engines using the first assembly are coded as (for example) "A¹" and the later engines with the second assembly are coded "A²".

Names of parts have been checked and made to agree with the names given in the Master Parts Price List except in a very few cases where additional nomenclature was required.

The illustrations of the individual parts do not necessarily picture all the differences between parts with the same item number because the illustrations would be too complicated for use if they did. Instead, the illustration shows a representative part for each item number.