

Model 250 Chain Saw

MODEL NO. 600100 SERIAL NUMBERS PREFIXED 11-, A11-, B11-, & C11-

ILLUSTRATED PARTS LIST

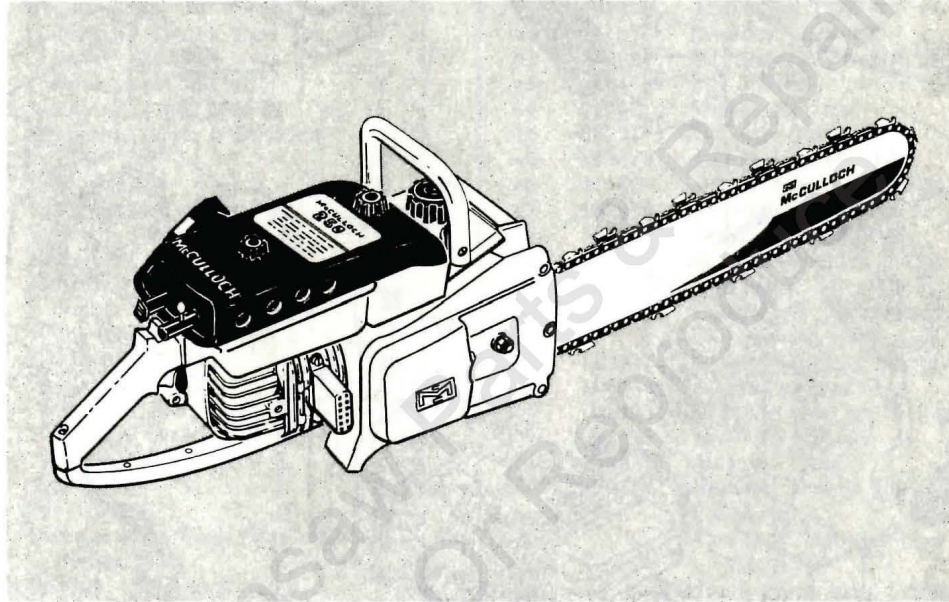

August 1969

The policy of McCulloch Corporation is one of continual improvement in design, manufacturing and engineering advancement wherever possible to assure still finer two-cycle power tools. Hence, specifications, equipment, colors, design and manufacturer's suggested list prices are subject to change without notice and McCulloch Corporation reserves the right to make such changes without prior notification or obligation to backfit or supply backfit components for units previously shipped from the factory.

	Page
Figure 1. General Exploded View	2
Figure 2. Starter and Crankcase Cover . . .	4
Figure 3. Oiler and Fuel Tank Assemblies .	6
Figure 4. Cover and Airbox Assemblies . . .	8
Figure 5. Carburetor	10
Figure 6. Powerhead	12
Figure 7. Clutch Guard, Bar and Chain . . .	14



McCULLOCH

MODEL 250

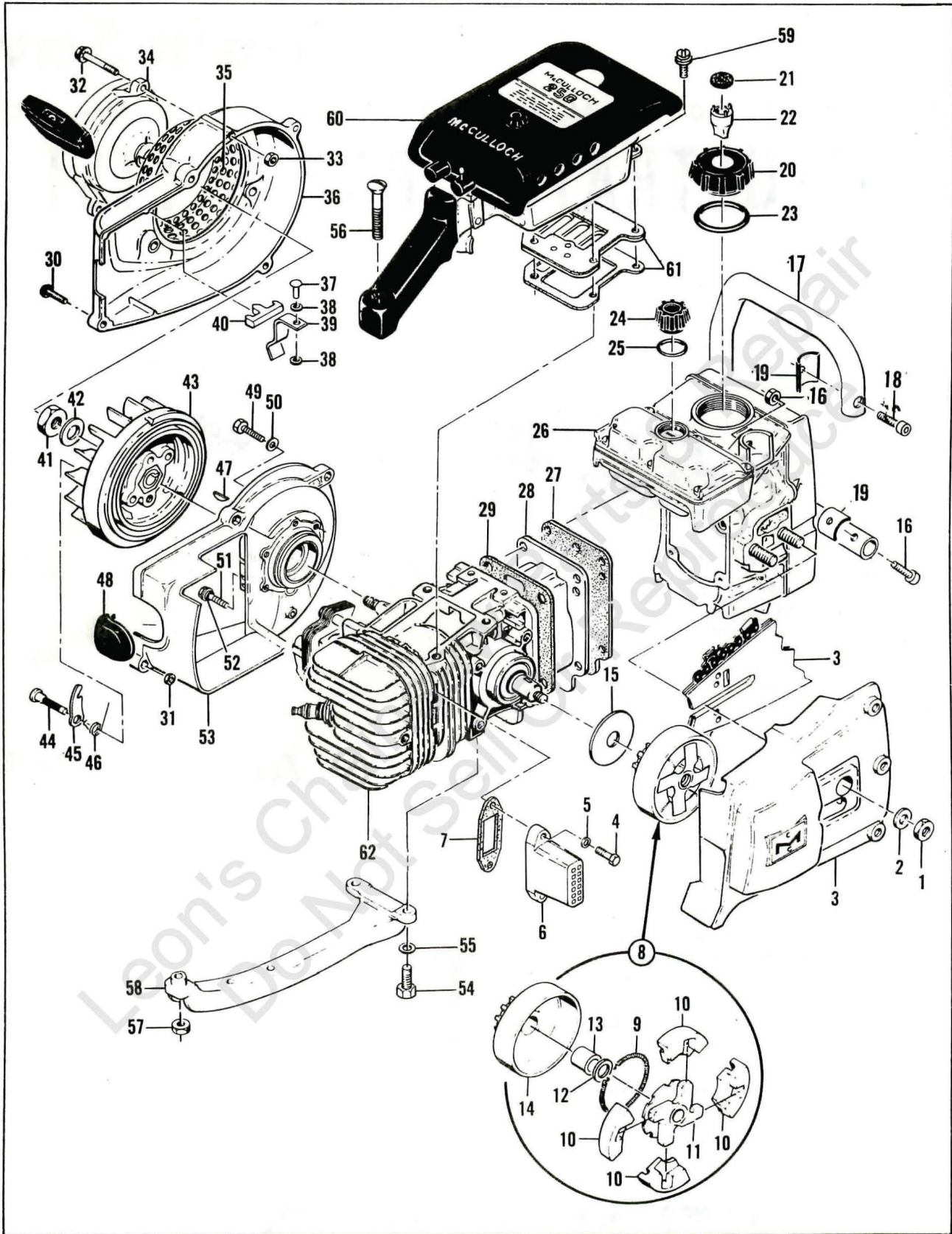

Figure 1. General Exploded View

FIGURE 1. GENERAL EXPLODED VIEW

Item No.	Part Number	Description	Units Per Assy
1	-110625	Nut - Hex 3/8-24	2
2	100006	Washer - Plain 3/8	2
3		Clutch Guard, Bar & Chain (See Figure 7)	
4	102289	Screw - Hex hd 10-24 x 3/4	2
5	103100	Lockwasher - #10 Internal	2
6	-65333	Pipe - Exhaust	1
7	53652	Gasket - Exhaust	1
8		Clutch, Sprocket, Drum & Bushing Assy	
	50060B	Clutch Assy	1
9	51468A	. Spring - Clutch shoe	1
10	51464A	. Shoe - Clutch	4
11	50144B	. Rotor Assy - Clutch	1
12	101270	Washer - Plain 7/16	1
	50129A	Sprocket, Drum & Bushing Assy	1
13	50128	. Bushing	1
14	51775B	. Sprocket & Drum Assy	1
15	50132	Washer - Special	1
16	101143	Nut - Hex 1/4-20	3
17	-83500	Frame	1
18	-105187	. Screw - Skt hd 1/4-20 x 1-1/8	3
19	-83233	. Spacer - Frame	3
20	55934B	Cap - Fuel	1
21	55063	. Filter - Fuel cap	1
22	53766A	. Valve - Fuel cap	1
23	101348	"O" Ring	1
24	57129A	Cap - Oiler	1
25	101148	"O" Ring	1
26		Oiler & Fuel Tank Assys (See Figure 3)	
27	-65669	Gasket - Fuel tank	1
28	-65371	Cover - Crankcase bottom	1
29	-65654	Gasket - Bottom	1
30	104815	Screw - 10-24 x 7/8 (SEMS)	4

Item No.	Part Number	Description	Units Per Assy
31	101326	Nut - Hex 10-24	2
32	104815	Screw - 10-24 x 7/8 (SEMS)	3
33	101191	Nut - Hex 10-24	3
34		Starter Assy (See Figure 2)	
35	50581A	Guard - Sawdust	1
36	57184B	Fan Housing Assy	1
37	103819	. Rivet - Oval hd 3/16 x 5/16	1
38	24236	. Washer - Special	2
39	50818	. Spring - Switch	1
40	50817	. Button - Switch	1
41	101179	Nut - Nex 7/16	1
42	101270	Washer - Special	1
43	-68282	Flywheel & Pawl Assy	1
44	36144B	Pin - Pawl	2
45	24093	Pawl - Starter	2
46	-66351	Spring - Pawl	2
47	103879	Key - Woodruff #3	1
48	57565	Cover Assy - Spark plug	1
49	102289	Screw - Hex hd 10-24 x 3/4	4
50	102189	Washer - Plain #10	3
51	55494	Screw - Sealing	2
52	55492	. Washer - Sealing	2
53		Crankcase Cover Assy (See Figure 2)	
54	100882	Screw - Hex hd 1/4-20 x 3/4	2
55	100004	Washer - Plain 1/4	2
56	104435	Screw - Oval hd 10-24 x 1-3/4	1
57	101191	Nut - Hex 10-24	1
58	-65332	Brace - Handle	1
59	110127	Screw - Hex hd 10-24 x 7/8 (SEMS)	2
60		Cover & Airbox Assys (See Figure 4)	
61		Reed Plate Assy & Insulator (See Figure 4)	
62		Powerhead Assy (See Figure 6)	

Part numbers which have changed since the previous printing of the illustrated parts list covering these saws, are indicated by a dash (-) preceding the new part number.

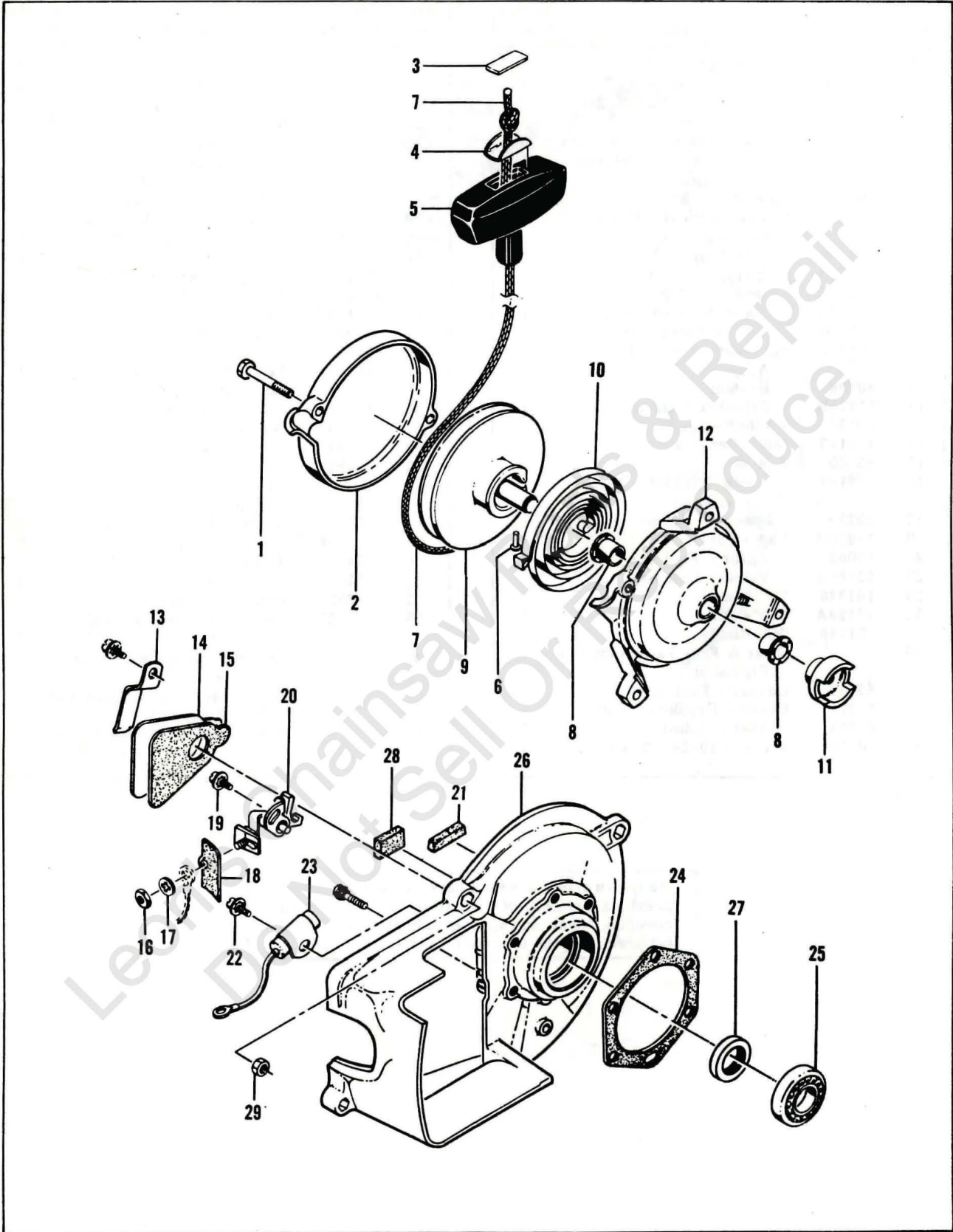

Figure 2. Starter and Crankcase Cover Assemblies

FIGURE 2. STARTER AND CRANKCASE COVER ASSEMBLIES

Item No.	Part Number	Description	Units Per Assy
	60130	Starter Assy	1
1	104396	. Screw - 10-24 x 3/4	2
2	60647	. Cover - Starter	1
3	57232	. Plate - Starter handle	1
4	57231	. Cup - Starter handle	1
5	57230	. Handle - Starter	1
6	101136	. Rivet	1
7	28716	. Rope - Starter	1
8	57535	. Bushing	2
9	57792	. Drum - Starter	1
10	51665	. Spring - Rewind	1
11	57790	. Ratchet - Starter	1
12	60646	. Base - Starter	1
13	50671	. Retainer - Breaker box cover	1
14	50588A	Cover - Breaker box	1
15	-65584	Gasket - Breaker box	1

Item No.	Part Number	Description	Units Per Assy
16	100251	Nut - Hex 8-32	1
17	100057	Lockwasher - #8	1
18	50381A	Insulator - Breaker terminal	1
19	103672	Screw - Hex hd 8-32 x 1/2 (SEMS)	1
20	50076A	Breaker Assy	1
21	50664	Felt - Breaker box	1
22	103672	Screw - Hex hd 8-32 x 1/2 (SEMS)	1
23	50074	Condenser	1
24	51240	Gasket - Crankcase	1
25	100824	Bearing - Ball	1
26	57126A	Crankcase Cover Assy	1
27	50663	. Seal - Oil	1
28	54184	. Wiper - Felt	1
29	101326	. Nut - Hex 10-24	2

Leon's Chainsaw Parts & Reproduction
Do Not Sell Or Reproduce

MODEL 250

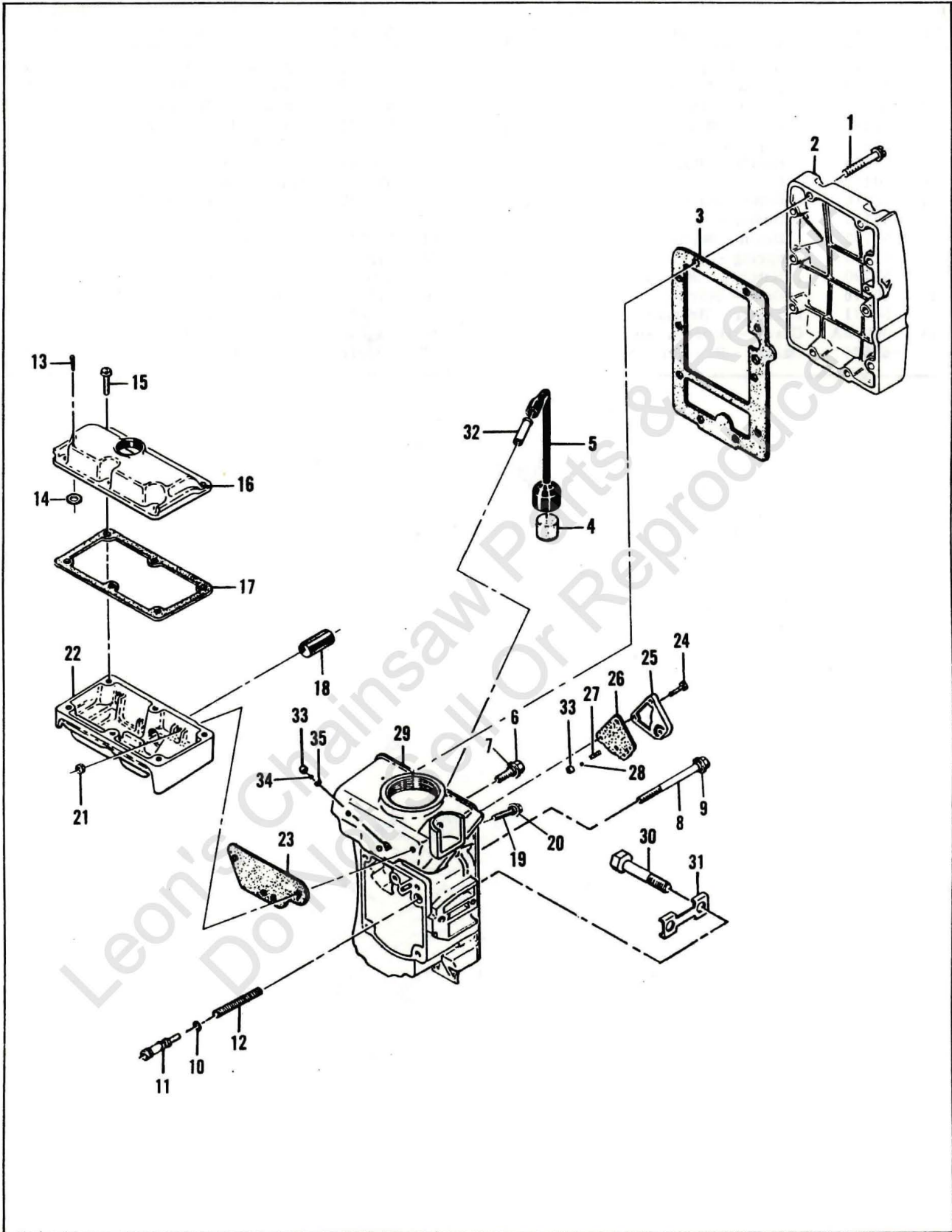

Figure 3. Oiler and Fuel Tank Assemblies

FIGURE 3. OILER TANK AND FUEL TANK ASSEMBLIES

Item No.	Part Number	Description	Units Per Assy
1	104396	Screw - Pan hd 10-24 x 3/4	10
2	-68988	Cover-Fuel tank	1
3	-65580	Gasket - Fuel tank	1
4	50124A	Filter - Fuel tank	1
5	50082	Hose - Fuel	1
6	57840	Screw Assy - Sealing	3
7	-50261	. Washer - Sealing	3
8	-50523	Screw Assy - Sealing	1
9	-50261	. Washer - Sealing	1
10	101056	"O" Ring	1
11 *	-83405	Piston - Oiler	1
12	-68705	Spring - Oiler	1
13	100010	Pin - Cotter 1/16 x 1/2	1
14	-69352	Washer - Felt	1
15	104395	Screw - Pan hd 10-24 x 5/8	6
16	57114A	Cover - Oil tank	1
17	57152	Gasket - Oil tank cover	1
18	57279	Screen - Oil tank	1

Item No.	Part Number	Description	Units Per Assy
19	55494	Screw Assy - Sealing	3
20	-55492	. Washer - Sealing	3
21	101326	Nut - Hex 10-24	3
22	-66618	Tank - Oiler	1
23	57147	Gasket - Oiler tank	1
24	103814	Screw - Hex hd 10-24 x 5/8	3
25	62339A	Plate - Pulse pump	1
26	-65673	Gasket - Pulse pump	1
27	63034	Spring - Check valve	1
28	100071	Ball - Check valve	1
29	62154A	Fuel Tank Assy	1
30	61437	. Bolt - Bar mounting	2
31	51439	. Lockplate	1
32	28042	. Tube - Fuel hose	1
33	62216	. Seat - Check valve	2
34	100071	. Ball - Check valve	1
35	110327	. Ring - Ball retainer	1

* See note on page 9 concerning installation of piston.

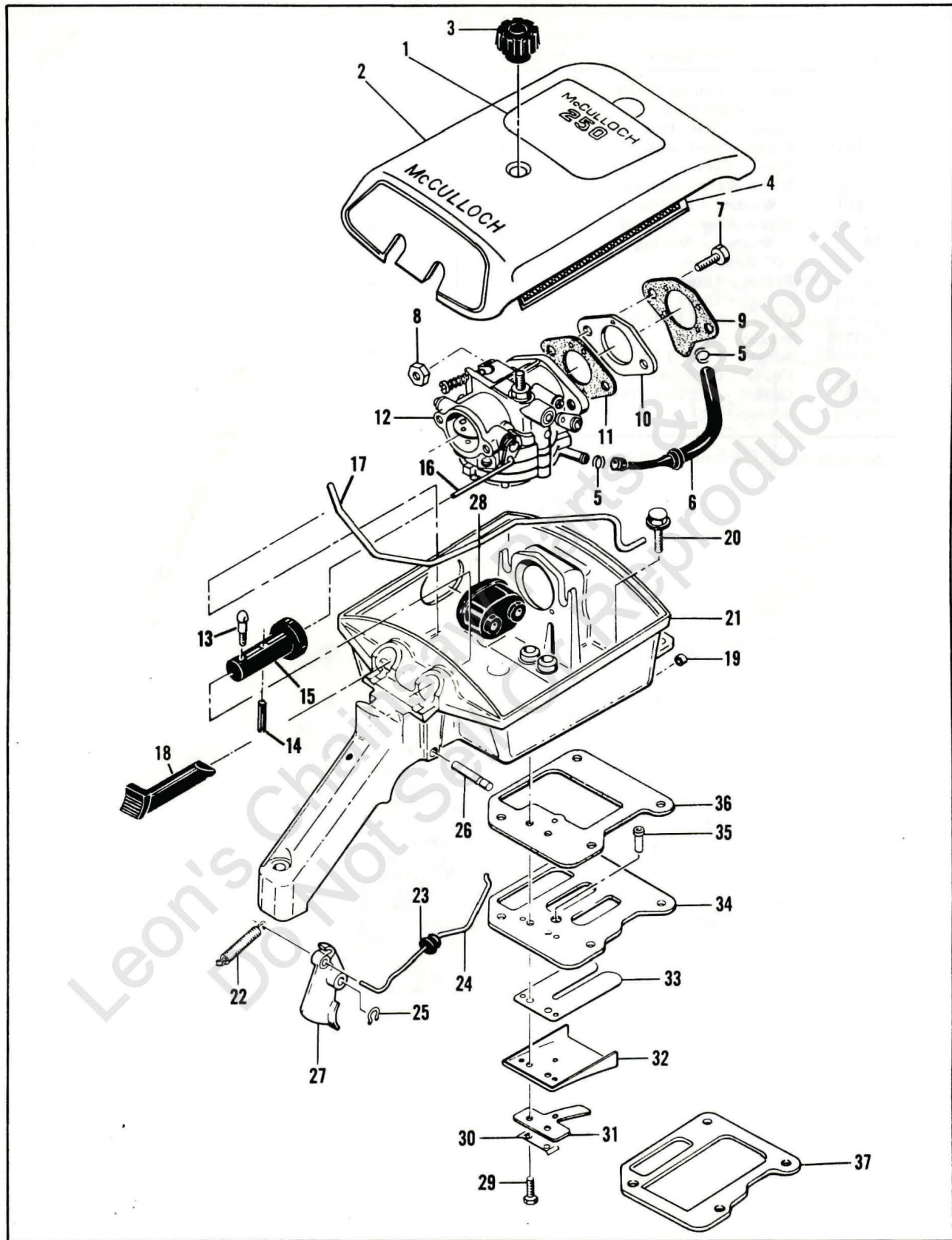

Figure 4. Cover and Airbox Assemblies

FIGURE 4. COVER AND AIRBOX ASSEMBLIES

Item No.	Part Number	Description	Units Per Assy
1	61931A	Nameplate	1
2	-67288	Cover Assy - Air cleaner	1
3	60242	. Knob - Air cleaner cover	1
4	55497	Screen - Air cleaner	1
5	50742	Clamp - Fuel hose	2
6	-67094	Hose - Fuel	1
7	53539	Screw - Hex hd 1/4-20 x 15/162	1
8	103242	Nut - Hex 1/4-20	2
9	-65583	Gasket - Adapter to airbox	1
10	50686A	Adapter - Carburetor	1
11	-65630	Gasket - Carburetor	1
12		Carburetor Assy (See Figure 5)	
13	61822	Screw - Special	1
14	101556	Pin - Roll	1
15	50777B	Button - Choke	1
16	57134	Pushrod - Choke	1
17 *	-83383	Pushrod - Oiler	1
18 *	-83397	Button - Oiler	1
19	57736	Washer - Felt	1
20	110127	Screw - Hex hd 10-24 x 7/8 (SEMS)	2

Item No.	Part Number	Description	Units Per Assy
21	-83421	Airbox Assy	1
22	36499	. Spring - Throttle	1
23	-68258	. Grommet - Throttle	1
24	50684	. Rod - Throttle	1
25	104501	. Retainer - Trigger pin	1
26	50507	. Pin - Trigger	1
27	50091B	. Trigger	1
28	-83404	. Grommet - Carburetor control	1
29	103740	. Screw - Hex hd 8-32 x 5/8	2
30	51480	. Lockplate	1
31	57658A	. Clamp - Reed	1
32	-66274	. Deflector - Fuel	1
33	48593	. Valve - Reed	1
34	53685C	. Plate - Reed	1
35	63067	. Tube	1
36	-65653	. Gasket - Airbox	1
37	62834	. Insulator - Reed plate	1

* NOTE: Initial production units of Model 250 saws with an 11- serial number prefix are furnished with Oiler Button, P/N 50591B, Oiler Pushrod, P/N 57866A, Oiler Piston, P/N 68704, and Piston Cup, P/N 67116, as illustrated below. These parts are not individually interchangeable with corresponding parts used on later production units. Any Model 250 saw equipped with these parts may quickly be identified by the shape of the button.

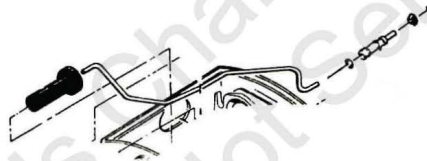

For service replacement of the oiler button, pushrod or piston on such units, order by the part number listed in this note instead of the part number listed for Item No. 11, Figure 3, and for Item Nos. 17 and 18, Figure 4.

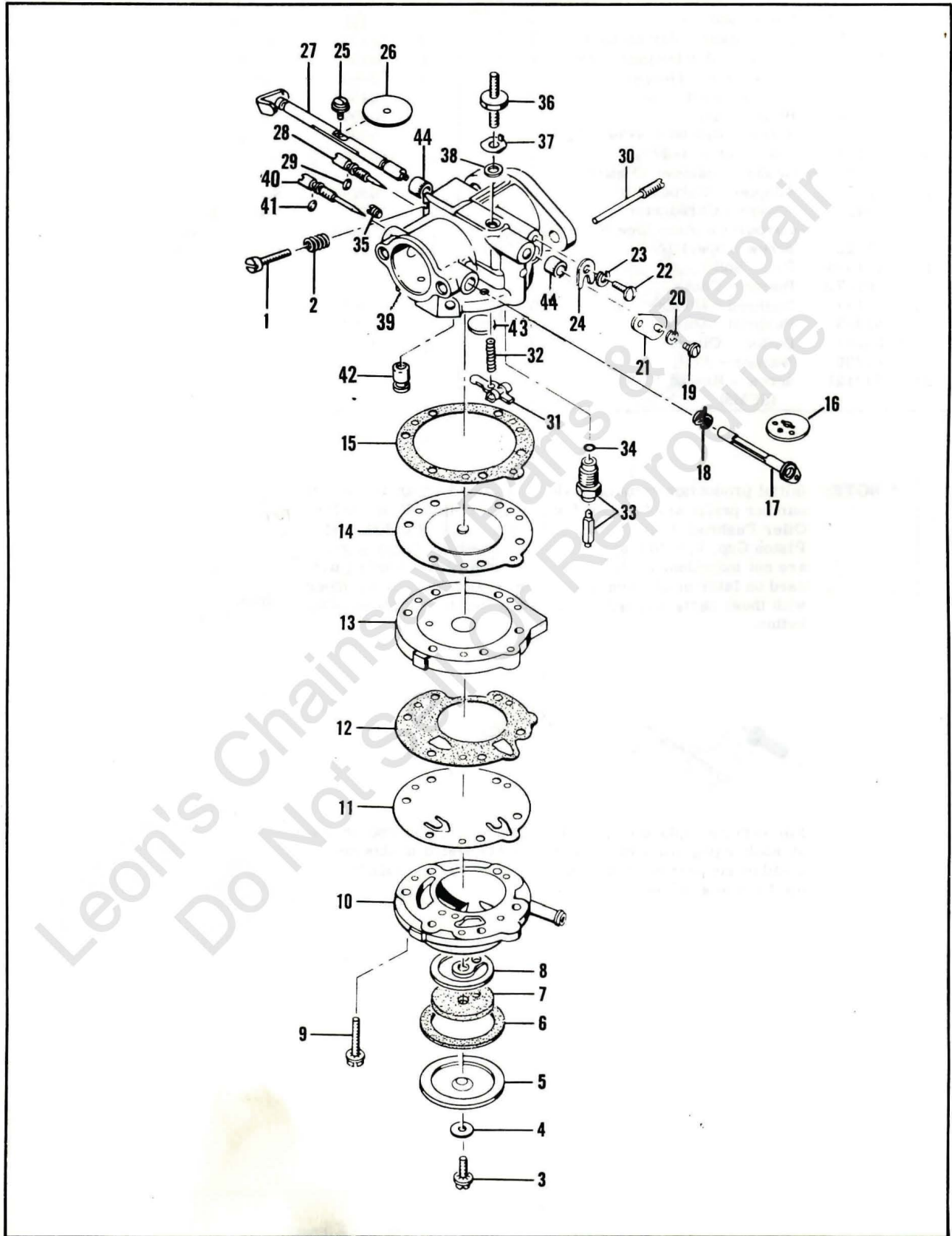

Figure 5. Carburetor

FIGURE 5. CARBURETOR

Item No.	Part Number	Description	Units Per Assy	Item No.	Part Number	Description	Units Per Assy
	66346	Carburetor Assy	1	25	*51721	. Screw - Throttle shutter	1
1	*50799	. Screw - Idle speed regulating	1	26	51720	. Shutter - Throttle	1
2	*51705	. Spring - Idle speed regulating screw	1	27	50803A	. Throttle Shaft & Lever	1
3	*50797	. Screw - Fuel filter cover	1	28	*51702	. Needle Assy - Idle adjustment	1
4	50798	. Gasket - Fuel filter cover	1	29	- 104001	. . "O" Ring	1
5	50796	. Cover - Fuel filter	1	30	*51710	. Screw - Inlet control lever pinion	1
6	51704	. Gasket - Fuel filter cover	1	31	*51709	. Lever - Inlet control	1
7	*53717	. Filter Element - Fuel	1	32	*66404	. Spring - Inlet tension	1
8	53565	. Gasket - Fuel filter	1	33	*51707A	. Seat & Needle Assy	1
9	51597	. Screw - Fuel pump body	6	34	51708	. Gasket - Inlet seat	1
10	50670	. Body - Fuel pump	1	35	51589	. Drain Screw - Diaphragm chamber	1
11	*51595	. Diaphragm - Fuel pump	1	36	50785	. Stud - Air cleaner attachment	1
12	- 65592	. Gasket - Fuel pump	1	37	63026	. Tab - Locking	1
13	51592	. Cover - Diaphragm	1	38	63945	. Gasket - Stud	1
14	*66167	. Diaphragm Assy	1	39	66230	. Body & Needle Assy - Carburetor	1
15	- 65591	. Gasket - Diaphragm	1	40	66405	. . Needle Assy - Main adjustment	1
16	53813	. Shutter - Choke	1	41	- 104001	. . . "O" Ring	1
17	53814	. Shaft & Lever - Choke	1	42	65611	. . . Check Valve	1
18	*51586	. Spring - Choke shaft return	1	43	*51583	. . . Plug - Welch	1
19	*51719	. Screw - Throttle governor lever	1	44	51715	. . . Bushing - Shaft	2
20	*100261	. Lockwasher	1		*50806	Gasket & Packing Set	1
21	51718	. Lever - Throttle governor	1		66422	Repair Parts Kit	1
22	*51717	. Screw - Throttle shaft clip	1				
23	*100252	. Lockwasher	1				
24	51716	. Clip - Throttle shaft	1				

*Indicates part in Repair Kit #66422

MODEL 250

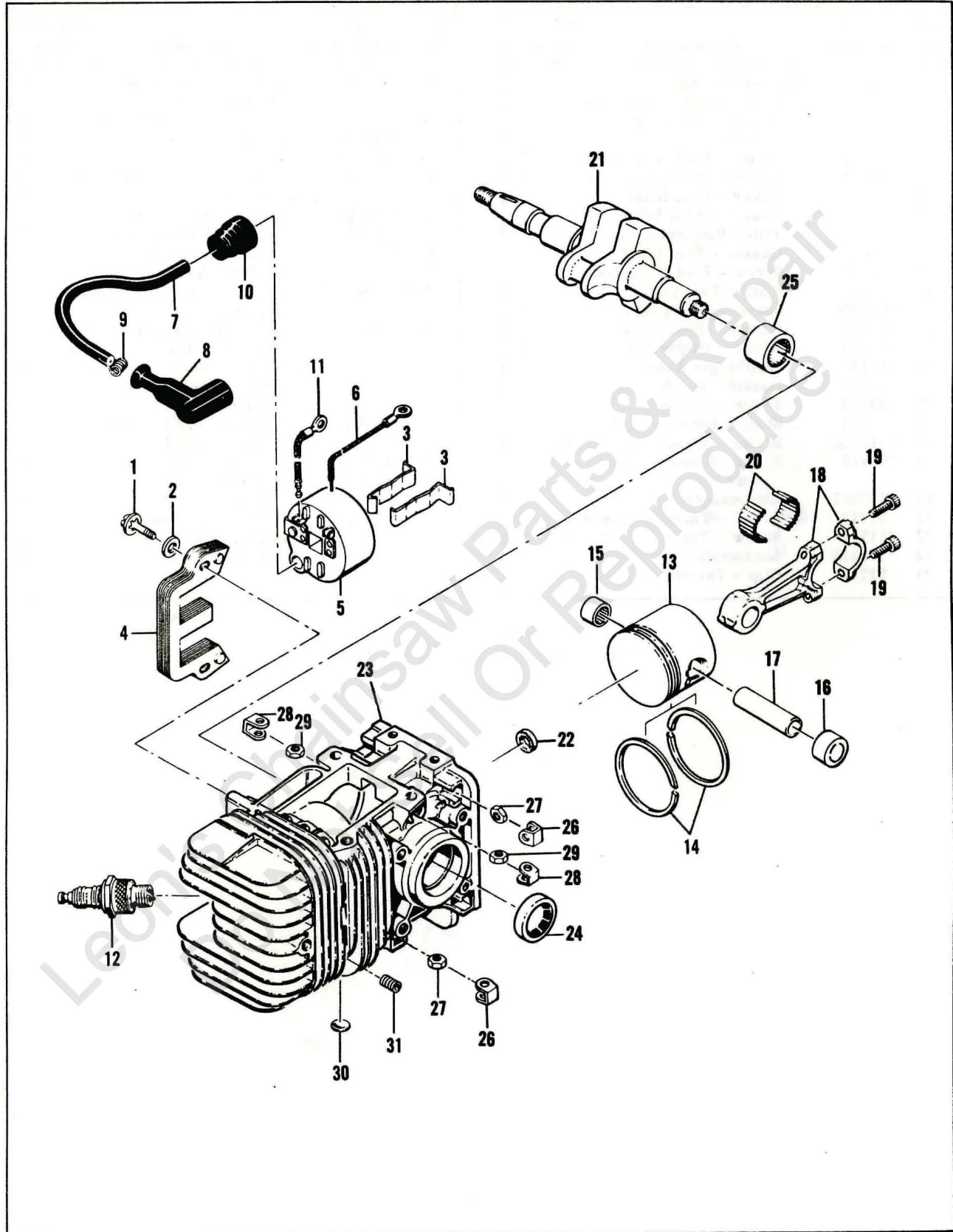

Figure 6. Powerhead

FIGURE 6. POWERHEAD

Item No.	Part Number	Description	Units Per Assy
1	104815	Screw - Hex hd 10-24 x 7/8	2
2	-100352	Washer - Plain #10	2
3	51253	Retainer - Coil	2
4	51251	Lamination Assy	1
5	-57643A	Coil & Terminal Assy	1
6	101883	. Wire Assy - Ground	1
7	52547	. Wire Assy - Spark plug	1
8	55060	. . Boot - Spark plug	1
9	55061	. . Connector	1
10	55617	. Nipple - Spark plug wire	1
11	57225	Wire Assy - Primary	1
12		Spark Plug - 14mm	1
13	53941A	Piston Assy	1
14	55123	. Ring Set - Piston	1
15	101206	. Bearing - Needle	1
16	104378	. Bearing - Needle (closed end)	1

Item No.	Part Number	Description	Units Per Assy
17	62831	Pin - Piston	2
18	47903	Rod Assy - Connecting	1
19	60210A	. Screw - Socket hd 10-32 x 0.552	2
20	-69891	. Roller - Needle	24
21	50659A	Crankshaft	1
22	-57736	Washer - Felt	1
23	62481	Cylinder Assy - Crankcase	1
24	104128	. Seal - Oil	1
25	104129	. Bearing - Needle	1
26	18556A	. Retainer - Nut	6
27	105394	. Nut - Hex 1/4-20	6
28	28053	. Retainer - Nut	2
29	101326	. Nut - Hex 10-24	2
30	110179	. Plug - Expansion	3
31	110034	. Insert - Tap-Lok	2

Leon's Chainsaw Parts & Reproduction
Do Not Sell Or Reproduce

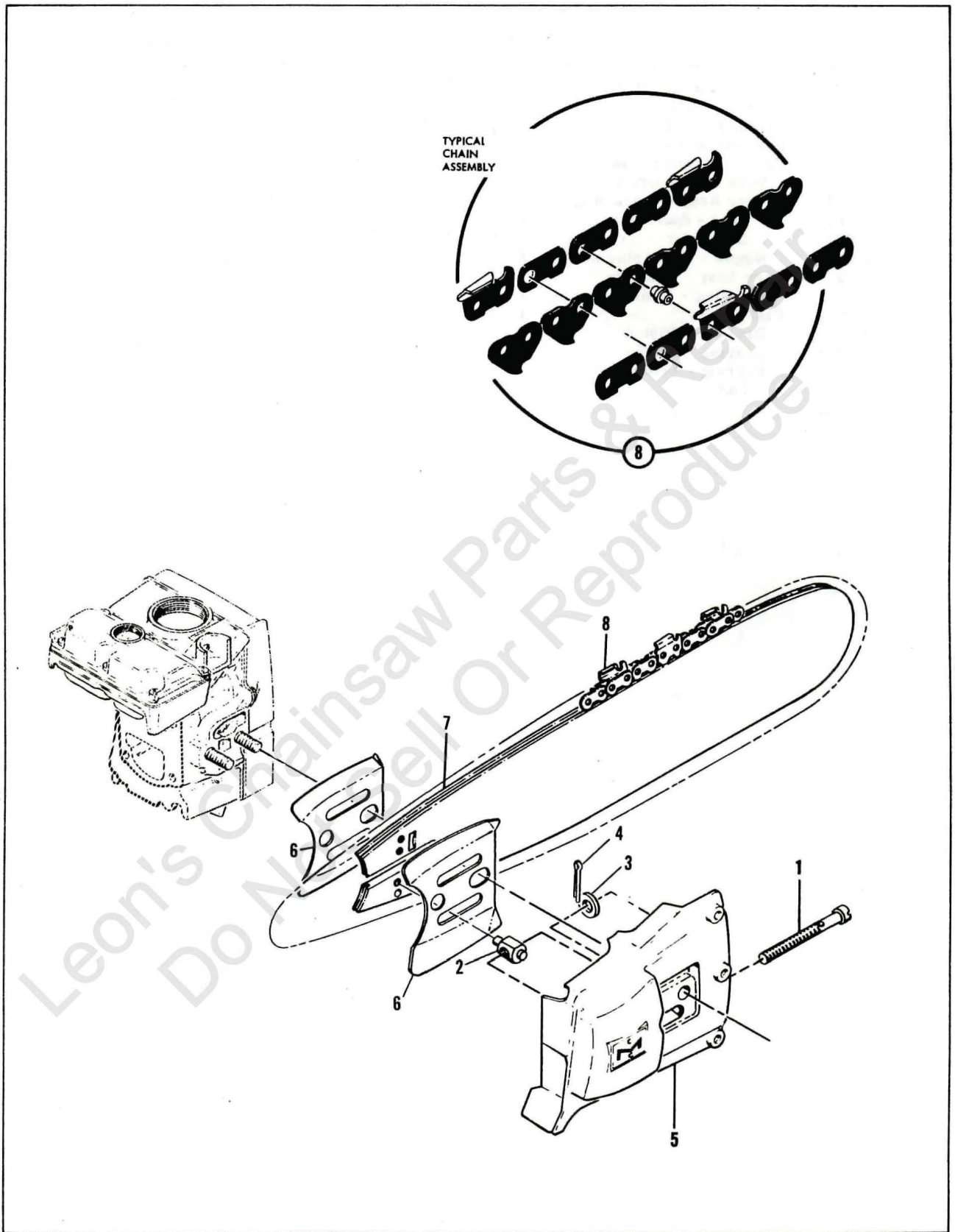

Figure 7. Clutch Guard, Bar and Chain

FIGURE 7. CLUTCH GUARD, BAR AND CHAIN

Item No.	Part Number	Description	Units Per Assy
	60133A	Guard Assy - Clutch	1
1	62057	. Screw - Fil hd 1/4-28 x 3-1/2	1
2	52207C	. Nut - Bar adjusting	1
3	100004	. Washer - Plain 1/4	1

Item No.	Part Number	Description	Units Per Assy
4	105686	. Pin - Cotter	1
5	60134	. Guard - Clutch	1
6	-64935	Plate - Bar	2
7		Bar	1
8		Chain	1

ACCESSORIES

Part Number	Description
-61040	Wrench & Screwdriver - Combination
-69550	Owner's Manual
61331	Kit - 4-tooth spike
61330	Kit - 5-tooth spike
53942A	Piston Assy - 0.010 in. oversize
55124	. Ring Set - 0.010 in. oversize

Part Number	Description
53943A	Piston Assy - 0.020 in. oversize
55125	. Ring Set - 0.020 in. oversize
53944A	Piston Assy - 0.030 in. oversize
55126	. Ring Set - 0.030 in. oversize
-36248	Wrench - Spark plug
-65712	Timing Guide



McCULLOCH



● MANUFACTURING ●

SALES ●

SERVICE ●

McCULLOCH CORPORATION

6101 WEST CENTURY BLVD., LOS ANGELES, CALIFORNIA 90045

INTERNATIONAL DIVISIONS:

LOS ANGELES, CALIF., P. O. BOX 45466

HONG KONG, B. C. C.: G. P. O. BOX 879

McCULLOCH OF CANADA LTD.

6338 VISCOUNT ROAD, MALTON, ONTARIO, CANADA

McCULLOCH OF EUROPE, N. V.

ANTOON SPINOYSTRAAT 5, MECHELEN, BELGIUM

McCULLOCH OF AUSTRALIA PTY., LTD.

P.O. BOX 165, GRANVILLE, N.S.W., 2142, AUSTRALIA

Leon's Oil & Air Tools & Repair
Do Not Buy Preproduced