

MASTER ILLUSTRATED PARTS LIST

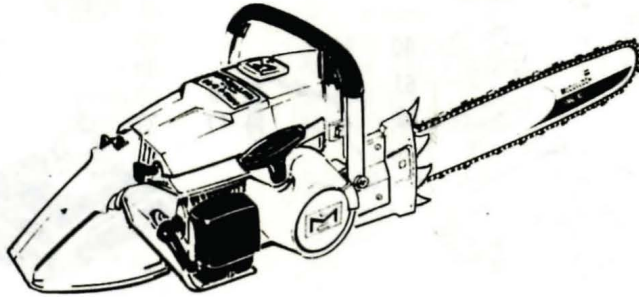

MAC 2-10G Chain Saw

FEBRUARY 1970

CONTENTS

The policy of McCulloch Corporation is one of continual improvement in design, manufacturing and engineering advancement wherever possible to assure still finer two-cycle power tools. Hence, specifications, equipment, colors, design and manufacturer's suggested list prices are subject to change without notice and McCulloch Corporation reserves the right to make such changes without prior notification or obligation to backfit or supply backfit components for units previously shipped from the factory.

	Page
Figure 1. General	2
Figure 2. Clutch and Starter Assembly	6
Figure 3. Fuel Tank Assembly	8
Figure 4. Fuel Tank Assembly	10
Figure 5. Carburetor Assembly	12
Figure 6. Carburetor Assembly	14
Figure 7. Carburetor Assembly	16
Figure 8. Transmission Assembly	18
Figure 9. Powerhead Assembly	20

This Master Illustrated Parts List gives the name, number and interchangeability between engines, of service and replacement parts which were used on or are presently available for all MAC 2-10G chain saws manufactured to date.

Information about the List and how to use it will be found on the back cover.
Read the information before you start to use the List.



MODEL 2-10G

Figure 1. General (Continued)

Item No.	Part Number	Description	Units Per Assy	Usable on Code
46	64848	Hose Assy - Fuel	1	All
47	63932	Filter - Fuel	1	All
48	100440	Washer	1	All
49	62978	Screw - Special	3	All
50	102762	Screw - Hex hd 10-24 x 1/2	1	All
51	69890	Lockplate	1	All
52	83521	Kit - Fan housing	1	All
53	55615	Guard - Flywheel	1	All
54	103355	Screw - Hex hd 10-24 x 1-7/8	2	A
	103124	Screw - Hex hd 10-24 x 2	2	B,C
55	64856	Washer - Special	2	A,B,C
56	68203	Washer - Insulator	2	A,B,C
57	62327A	Sleeve	2	A
	65726	Sleeve	2	B,C
58		Carburetor Assy (See Figure 5)		A
		Carburetor Assy (See Figure 6)		B,C
59	62066A	Rod - Primer	1	A
	65604	Rod - Primer	1	B,C
60	65672	Gasket - Carburetor	1	A
61	65821	Insulator - Carburetor	1	B,C
62	65672	Gasket - Insulator	1	B,C
63	110551	Screw - Hex hd 10-24 x 2-1/8	2	D
64	66681	Bracket Assy	1	D
65		Carburetor Assy (See Figure 7)		D
66	68132	Gasket - Carburetor	1	D
67	66678	Spacer - Carburetor	1	D
68	68131	Gasket - Spacer	1	D
69	110553	Screw - Hex hd 10-24 x 1-3/8	2	D
70	68582	Lockplate	2	D
71	66189	Sleeve	2	D
72	110516	Screw - Hex hd 10-24 x 1-1/8	1	All
73	63475	Lockplate	1	All
74	64856	Washer - Special	1	All
75	110353	Screw - Oval hd 10-24 x 3/8	1	All
76	102289	Screw - Hex hd 10-24 x 3/4	1	All
77	69890	Lockplate	1	All
78	69838	Brace - Handle	1	All
79		Fuel Tank Assy (See Figure 3)		A,B,C
		Fuel Tank Assy (See Figure 4)		D
80	68130	Gasket - Fuel tank	2	All
81	66659	Insulator - Fuel tank	1	A,B,C
	66659	Insulator - Fuel tank	1	D
82	68194	Kit - Spark arrester	1	All
83	102290	Screw - Hex hd 10-24 x 1-1/8	2	All
84	110264	Washer - #10	2	All
85	62380	Cover	1	All
86	62379B	Baffle	1	All
87	67922	Lockplate	1	All
88	83105	Body and Duct Assy	1	All
89	68187	Screw - Special	1	All
90	110506	Screw - Hex hd 10-24 x 5/8	1	All
91	110341	Screw - Hex hd 10-24 x 1/2	1	All
92	63748	Gasket - Spark arrester	1	A,B,C
	68149	Gasket - Spark arrester	1	D
93	67377	Shroud	1	All
94	62085A	Insulator - Shroud	2	All
95		Powerhead Assy (See Figure 9)		All

Figure 1. General

Item No.	Part Number	Description	Units Per Assy	Usable on Code										
		MAC 2-10G USABLE ON CODE												
		<table border="1"> <thead> <tr> <th>Letter</th> <th>A</th> <th>B</th> <th>C</th> <th>D</th> </tr> </thead> <tbody> <tr> <td>Serial Numbers</td> <td>Without Prefix</td> <td>Prefix 1-</td> <td>Prefix 2-</td> <td>Prefix 11-</td> </tr> </tbody> </table>	Letter	A	B	C	D	Serial Numbers	Without Prefix	Prefix 1-	Prefix 2-	Prefix 11-		
Letter	A	B	C	D										
Serial Numbers	Without Prefix	Prefix 1-	Prefix 2-	Prefix 11-										
1		Bar and Chain Assy (See Figure 8)		All										
2	102761	Screw - Hex hd 10-24 x 7/8	2	All										
3	100352	Washer - #10	2	All										
4	61678	Plug - Nut retainer	1	All										
5	101326	Nut - Hex 10-24	2	All										
6	105187	Screw - Skt hd 1/4-20 x 1-1/8	1	A,B										
7	105043	Lockwasher - 1/4	1	A,B										
8	100004	Washer - 1/4	1	A,B										
9	67372	Frame and Grip Assy	1	A,B										
10	110448	Screw - Skt hd 10-24 x 3-1/4	1	C,D										
11	103174	Lockwasher - #10	1	C,D										
12	100003	Washer - #10	1	C,D										
13	68503	Bracket - Frame	1	C,D										
14	102130	Screw - Hex hd 1/4-20 x 1-1/2	1	C,D										
15	100153	Lockwasher - 1/4	1	C,D										
16	63484	Clamp - Frame	1	C,D										
17	68458	Frame and Grip Assy	1	C,D										
18	62271	Plug - Frame	1	C,D										
19	104139	Screw - Oval hd 10-24 x 1-1/2	1	A,B										
20	110403	Screw - Oval hd 8-32 x 5/8	1	All										
21		Starter Assy (See Figure 2)		All										
22	103746	Nut - Hex 3/8-24	1	All										
23		Clutch Assy (See Figure 2)		All										
24	103879	Key - Woodruff	1	All										
25	63493	Drum, Gear and Seal Assy	1	All										
26	63476	Seal	1	All										
27	102765	Screw - Hex hd 10-24 x 1-3/4	2	All										
28	100003	Washer - #10	2	All										
29		Transmission Assy (See Figure 8)		All										
30	106104	"O" Ring	1	All										
31	62117	Cover Assy - Air cleaner	1	A										
	65866	Cover Assy - Air cleaner	1	B,C										
	66597	Cover Assy - Air cleaner	1	D										
32	62434	Nut - Cover	1	A										
	65813	Nut - Cover	1	B,C										
	66290	Nut - Cover	1	D										
33	66665	Spacer - Nut	1	D										
34	65458	Nameplate	1	A,B,C										
	67459	Nameplate	1	D										
35	62077	Filter - Air	1	A										
	66774	Filter - Air	1	B,C										
	68520	Filter - Air	1	D										
36	68531	Cap Assy - Fuel	1	All										
37	68533	Plug	1	All										
38	63041	Valve	1	All										
39	62316	Guide	1	All										
40	63040	Spring	1	All										
41	65671	Gasket	1	All										
42	110334	Screw - Oval hd 12-24 x 1-3/4	1	A,B,C										
	110402	Screw - Oval hd 12-24 x 2-3/8	1	D										
43	63656	Cover - Fuel tank	1	A,B,C										
	63288	Cover - Fuel tank	1	D										
44	69686	Spacer - Cover	1	D										
45	69345	Gasket - Cover	1	All										

SERVICE SPECIFICATIONS

Spark Plug Gap -----	0.025 in.
Lamination Gap -----	0.010 to 0.015 in.
Breaker Point Gap -----	0.018 in.
Torque Values	
Flywheel Nut -----	240 to 300 inch-pounds.
Clutch Nut -----	160 to 170 inch-pounds.
Connecting Rod Screws -----	65 to 70 inch-pounds.

Master Illustrated Parts List, P/N 84484, supersedes and cancels all previous lists issued for the MAC 2-10G saw. Discard the following lists:

- IPL 63498 covering saws having serial numbers without prefix.
- IPL 65639 and
 - Parts list sheet 66122 covering saws having serial numbers prefixed 1-.
 - Parts list sheet 66709 covering saws having serial numbers prefixed 2-.
- IPL 67460 covering saws having serial numbers prefixed 11-.

**MODEL
2-10G**

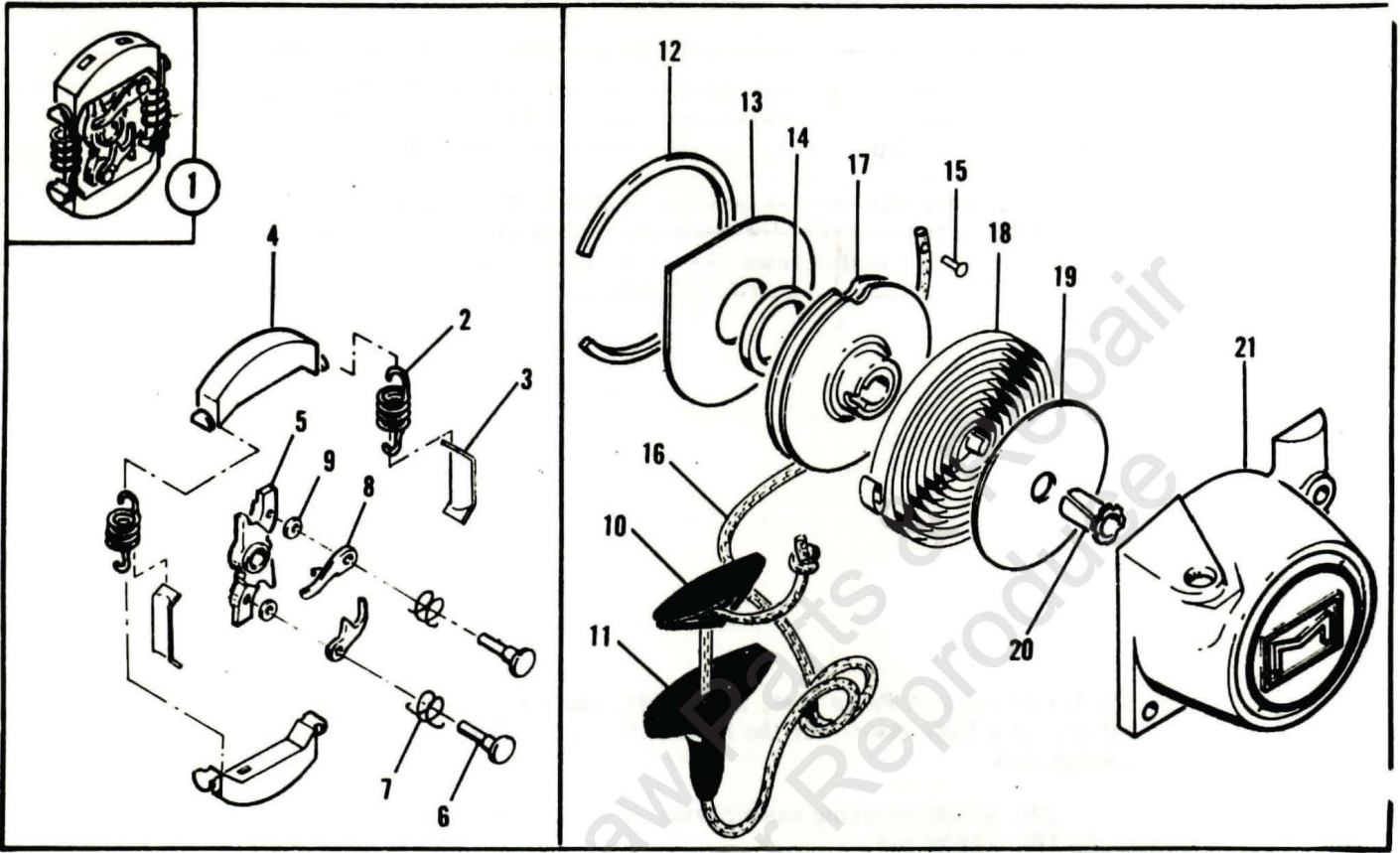

Figure 2. Clutch and Starter Assemblies

Figure 2. Clutch and Starter Assemblies

Item No.	Part Number	Description	Units Per Assy	Usable on Code										
MAC 2-10G USABLE ON CODE														
<table border="1" style="width: 100%; border-collapse: collapse;"> <thead> <tr> <th style="width: 15%;">Letter</th> <th style="width: 20%;">A</th> <th style="width: 20%;">B</th> <th style="width: 20%;">C</th> <th style="width: 25%;">D</th> </tr> </thead> <tbody> <tr> <td>Serial Numbers</td> <td>Without Prefix</td> <td>Prefix 1-</td> <td>Prefix 2-</td> <td>Prefix 11-</td> </tr> </tbody> </table>					Letter	A	B	C	D	Serial Numbers	Without Prefix	Prefix 1-	Prefix 2-	Prefix 11-
Letter	A	B	C	D										
Serial Numbers	Without Prefix	Prefix 1-	Prefix 2-	Prefix 11-										
1	67148	Clutch Assy	1	All										
2	66384	. Spring - Clutch	2	All										
3	64583	. Retainer - Spring	2	All										
4	67233	. Shoe - Clutch	2	All										
5	67149	. Rotor Assy	1	All										
6	67112	. . Rivet	2	All										
7	68837	. . Spring - Pawl	2	All										
8	64857	. . Pawl	2	All										
9	83694	. . Washer	2	All										
	67058	Starter Assy	1	All										
10	62191A	. Insert - Handle	1	All										
11	62190A	. Handle	1	All										
12	67205	. Retainer - Shield	1	All										
13	63985	. Shield - Dust	1	All										
14	63986	. Washer - Thrust	1	All										
15	110470	. Rivet - Rope	1	All										
16	69964	. Rope - Starter	1	All										
17	68695	. Drum - Starter	1	All										
18	68626	. Spring - Rewind	1	All										
19	63987	. Shield - Spring	1	All										
20	61635A	. Bushing - Nyliner	1	All										
21	67059	. Housing - Starter	1	All										

Leon's Chain & Sprocket Parts & Repair
Do Not Sell Or Reproduce

MODEL
2-10G

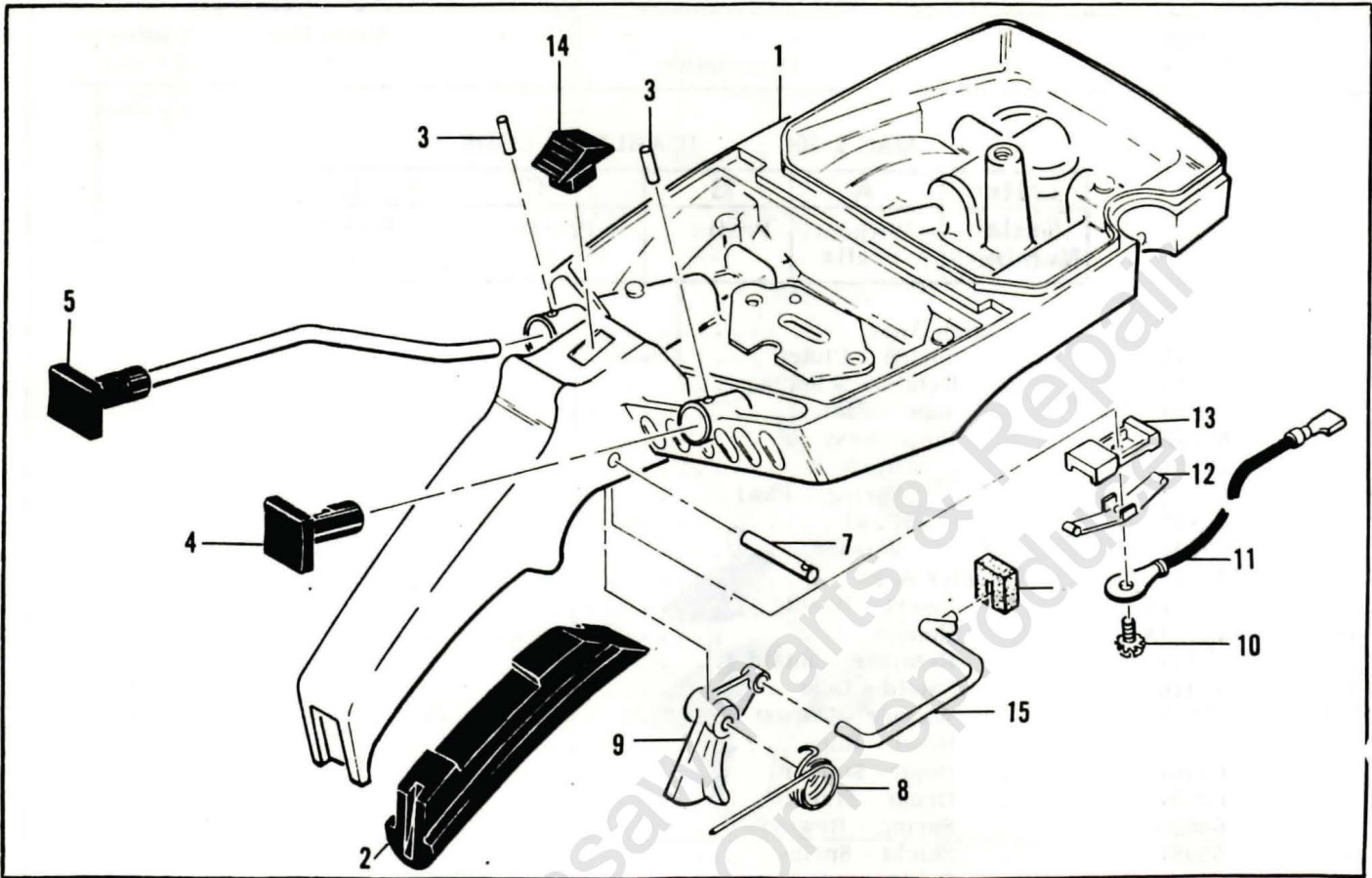

Figure 3. Fuel Tank Assembly

Figure 3. Fuel Tank Assembly

Item No.	Part Number	Description	Units Per Assy	Usable on Code										
		MAC 2-10G	USABLE ON CODE											
		<table border="1" style="width: 100%; border-collapse: collapse;"> <thead> <tr> <th style="width: 20%;">Letter</th> <th style="width: 20%;">A</th> <th style="width: 20%;">B</th> <th style="width: 20%;">C</th> <th style="width: 20%;">D</th> </tr> </thead> <tbody> <tr> <td>Serial Numbers</td> <td>Without Prefix</td> <td>Prefix 1-</td> <td>Prefix 2-</td> <td>Prefix 11-</td> </tr> </tbody> </table>	Letter	A	B	C	D	Serial Numbers	Without Prefix	Prefix 1-	Prefix 2-	Prefix 11-		
Letter	A	B	C	D										
Serial Numbers	Without Prefix	Prefix 1-	Prefix 2-	Prefix 11-										
1	66648	Fuel Tank Assy	1	A,B,C										
2	64872	Grip - Handle	1	A,B,C										
3	105673	Pin - Roli 3/32 x 9 16	2	A,B,C										
4	66194	Button - Primer	1	A,B,C										
5	64871	Button and Rod Assy - Oiler	1	A,B,C										
6	67989	Seal - Throttle rod	1	A,B,C										
7	110378	Pin - Roll 3/16 x 15 16	1	A,B,C										
8	65734	Spring - Trigger	1	A,B,C										
9	67224	Trigger - Throttle	1	A,B,C										
10	103672	Screw - Fil hd 8-32 x 1/2 (SEMS)	1	A,B,C										
11	62973A	Wire Assy - Stop switch	1	A,B,C										
12	62451	Contact - Switch	1	A,B,C										
13	62950A	Base - Switch	1	A,B,C										
14	62951	Button - Switch	1	A,B,C										
15	65816	Rod - Throttle	1	A,B,C										

Leon's Chainsaw Parts & Repair
Do Not Sell Or Reproduce

**MODEL
2-10G**

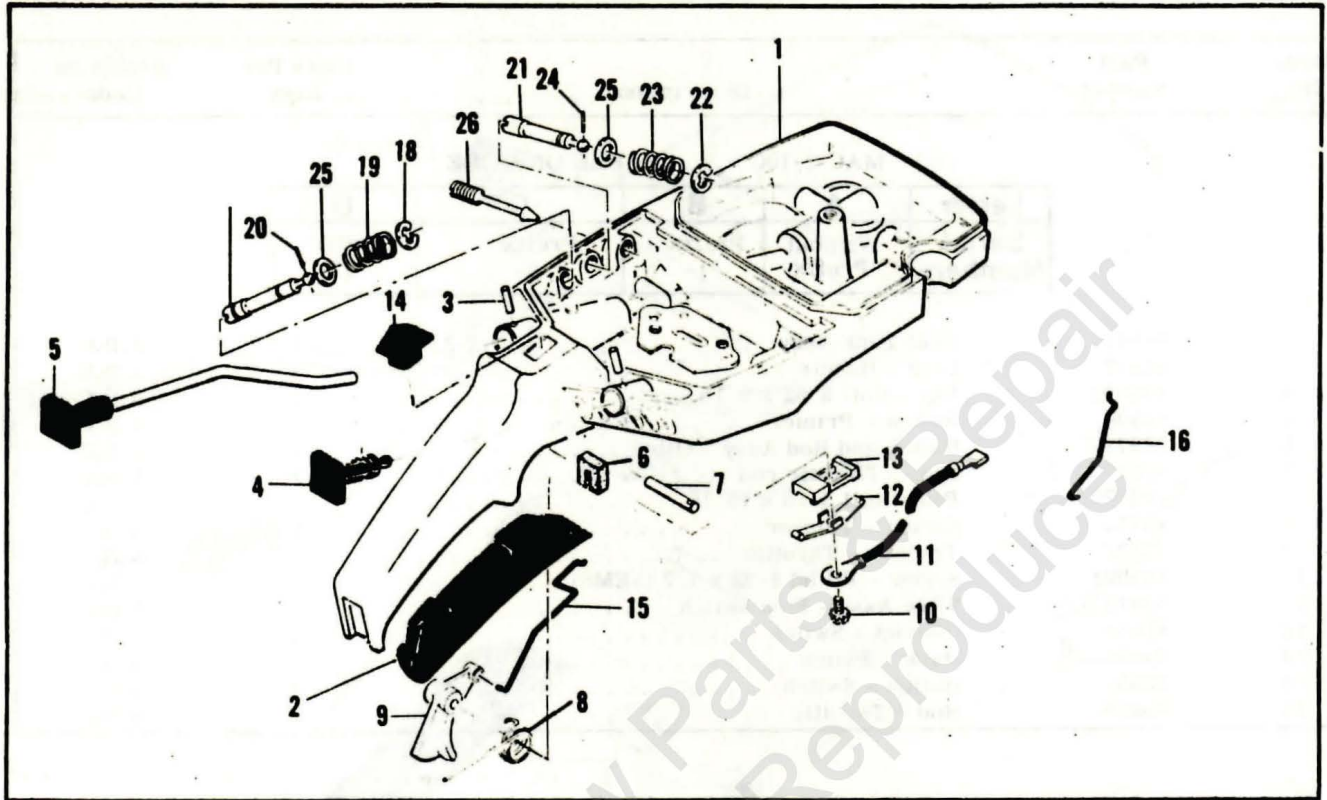

Figure 4 Fuel Tank Assembly

Figure 4. Fuel Tank Assembly

Item No.	Part Number	Description	Units Per Assy	Usable on Code										
		MAC 2-10G USABLE ON CODE												
		<table border="1" style="width: 100%; border-collapse: collapse;"> <thead> <tr> <th style="width: 15%;">Letter</th> <th style="width: 20%;">A</th> <th style="width: 20%;">B</th> <th style="width: 20%;">C</th> <th style="width: 25%;">D</th> </tr> <tr> <th>Serial Numbers</th> <td>Without Prefix</td> <td>Prefix 1-</td> <td>Prefix 2-</td> <td>Prefix 11-</td> </tr> </thead> </table>	Letter	A	B	C	D	Serial Numbers	Without Prefix	Prefix 1-	Prefix 2-	Prefix 11-		
Letter	A	B	C	D										
Serial Numbers	Without Prefix	Prefix 1-	Prefix 2-	Prefix 11-										
1	68683	Fuel Tank Assy	1	D										
2	64872	Grip - Handle	1	D										
3	105673	Pin - Roll 3/32 x 9/16	2	D										
4	68517	Button - Choke	1	D										
5	64871	Button and Rod Assy - Oiler	1	D										
6	67989	Seal - Throttle rod	1	D										
7	110378	Pin - Roll 3/16 x 15/16	1	D										
8	65734	Spring - Trigger	1	D										
9	67224	Trigger - Throttle	1	D										
10	103672	Screw - Fil hd 8-32 x 1/2 (SEMS)	1	D										
11	62973A	Wire Assy - Stop switch	1	D										
12	62451	Contact - Switch	1	D										
13	62950A	Base - Switch	1	D										
14	62951	Button - Switch	1	D										
15	68170	Rod - Throttle	1	D										
16	67355	Rod - Choke	1	D										
17	68102	Extension Assy - High speed	1	D										
18	110512	Ring - Retaining	1	D										
19	67363	Spring	1	D										
20	110509	Pin - Groove	1	D										
21	68101	Extension Assy - Idle	1	D										
22	110512	Ring - Retaining	1	D										
23	67363	Spring	1	D										
24	110509	Pin - Groove	1	D										
25	67292	Washer	2	D										
26	67271	Screw - Idle adjustment	1	D										

Leon's Charcoal Saw Parts & Repair
Do Not Sell Or Reproduce

**MODEL
2-10G**

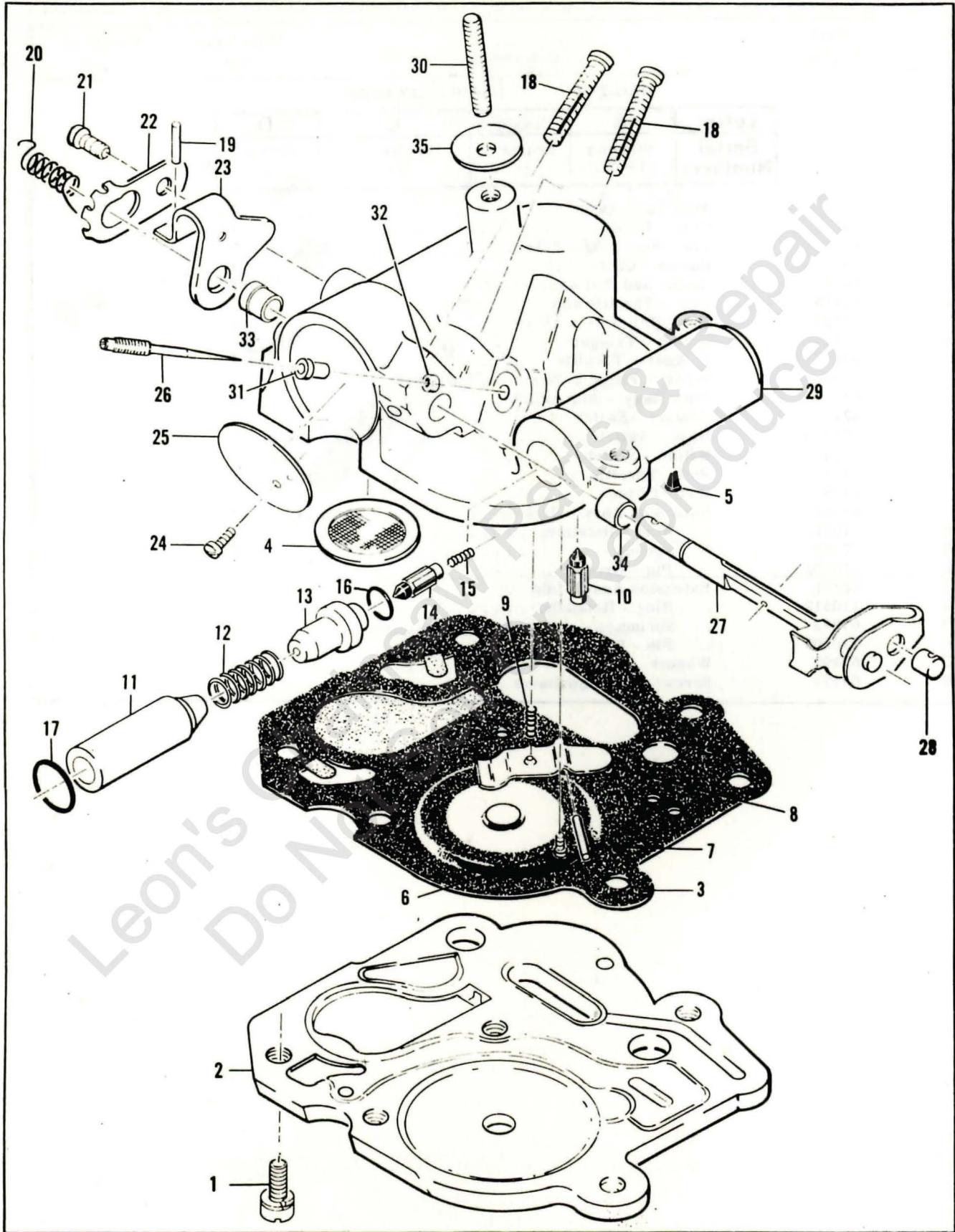

Figure 5 Carburetor Assembly

Figure 5. Carburetor Assembly

Item No.	Part Number	Description	Units Per Assy	Usable on Code										
		MAC 2-10G USABLE ON CODE												
		<table border="1"> <thead> <tr> <th>Letter</th> <th>A</th> <th>B</th> <th>C</th> <th>D</th> </tr> <tr> <th>Serial Numbers</th> <th>Without Prefix</th> <th>Prefix 1-</th> <th>Prefix 2-</th> <th>Prefix 11-</th> </tr> </thead> </table>	Letter	A	B	C	D	Serial Numbers	Without Prefix	Prefix 1-	Prefix 2-	Prefix 11-		
Letter	A	B	C	D										
Serial Numbers	Without Prefix	Prefix 1-	Prefix 2-	Prefix 11-										
	66564	Carburetor Assy (McCulloch Single Needle) . . .	1	A										
1	110397	. Screw - Pan hd 8-32 x 7/16 (SEMS)	5	A										
2	65597	. Plate - Carburetor base	1	A										
3	67357	. Diaphragm Assy - Pump	1	A										
4	55690B	. Seal - Capillary	1	A										
5	63041	. Valve - Primer	1	A										
6	104728	. Screw - 6-32 x 1/4	1	A										
7	110337	. Pin - Inlet lever	1	A										
8	62310	. Lever - Inlet	1	A										
9	62923A	. Spring - Inlet needle	1	A										
10	63038	. Valve - Inlet needle	1	A										
11	62308A	. Plunger - Primer	1	A										
12	11086	. Spring - Plunger	1	A										
13	63037	. Seat - Primer valve	1	A										
14	63038	. Valve - Primer needle	1	A										
15	63039	. Spring - Needle valve	1	A										
16	101056	. "O" Ring	1	A										
17	105606	. "O" Ring	1	A										
18	62971	. Screw - Long locking adjusting	2	A										
19	104245	. Pin - Roll 1 16 x 1 2	1	A										
20	62939A	. Spring - Idle governor	1	A										
21	103934	. Screw - Pan hd 6-32 x 1 4 (SEMS)	1	A										
22	62938	. Clip - Throttle shaft	1	A										
23	62343A	. Lever - Throttle	1	A										
24	104814	. Screw - Pan hd 4-40 x 1 4 (SEMS)	1	A										
25	62290A	. Plate - Throttle	1	A										
26	62976A	. Needle - Metering	1	A										
27	62291A	. Shaft Assy - Throttle	1	A										
28	62975	. Swivel - Needle	1	A										
29	63019B	. Body Assy - Carburetor	1	A										
30	62433B	. Stud - Carburetor	1	A										
31	62295D	. Orifice - Air	1	A										
32	66569	. Orifice - Fuel	1	A										
33	62288A	. Bushing - Throttle shaft	1	A										
34	62368	. Bushing - Throttle shaft	1	A										
35	67062	. Seal - Air cleaner stud	1	A										

- MCCULLOCH SINGLE NEEDLE CARBURETOR ADJUSTMENT**
1. Turn Lo Speed screw counterclockwise until it no longer touches stop and butterfly can be completely closed.
 2. Hold finger against closed butterfly and turn Lo Mix needle clockwise until butterfly starts to open. Turn the needle counterclockwise three turns.
 3. Hold finger against closed butterfly and turn Lo Speed screw clockwise until butterfly starts to open. Turn the screw one half turn more.
 4. Turn the Lo Mix needle in or out (leaner or richer) to obtain a smooth rapid acceleration. Roll the engine right and left, bar up and bar down. Check for smooth idle in all positions and adjust Lo Mix needle as necessary.
 5. Set tension on the idle governor spring so that the engine idles smoothly in all positions and after any change in position. If chain moves after position change, reduce tension.
 6. Adjust Hi Mix screw for maximum power under load. Make sure that when trigger is released the engine does not speed up before returning to idle. Turn screw clockwise until engine slows down immediately after trigger release. **DO NOT TOUCH LO MIX NEEDLE. ADJUST FOR HIGH SPEED OPERATION WITH HI MIX SCREW ONLY.**
 7. With throttle in wide open position, adjust Hi Mix screw to set butterfly in horizontal position. Now turn screw clockwise until butterfly just starts to close.
 8. Set tension on idle governor spring to hold butterfly slightly open.

**MODEL
2-10G**

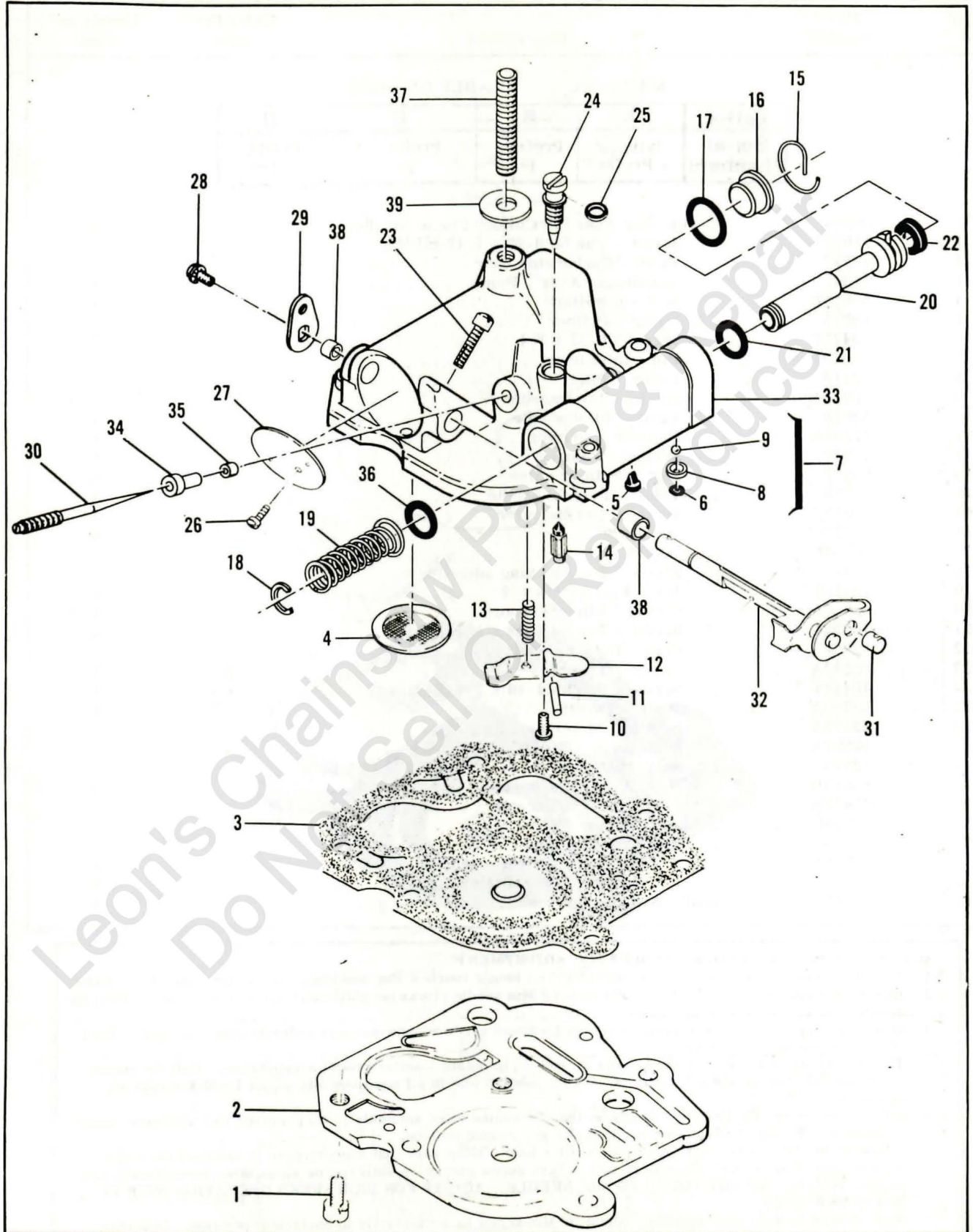
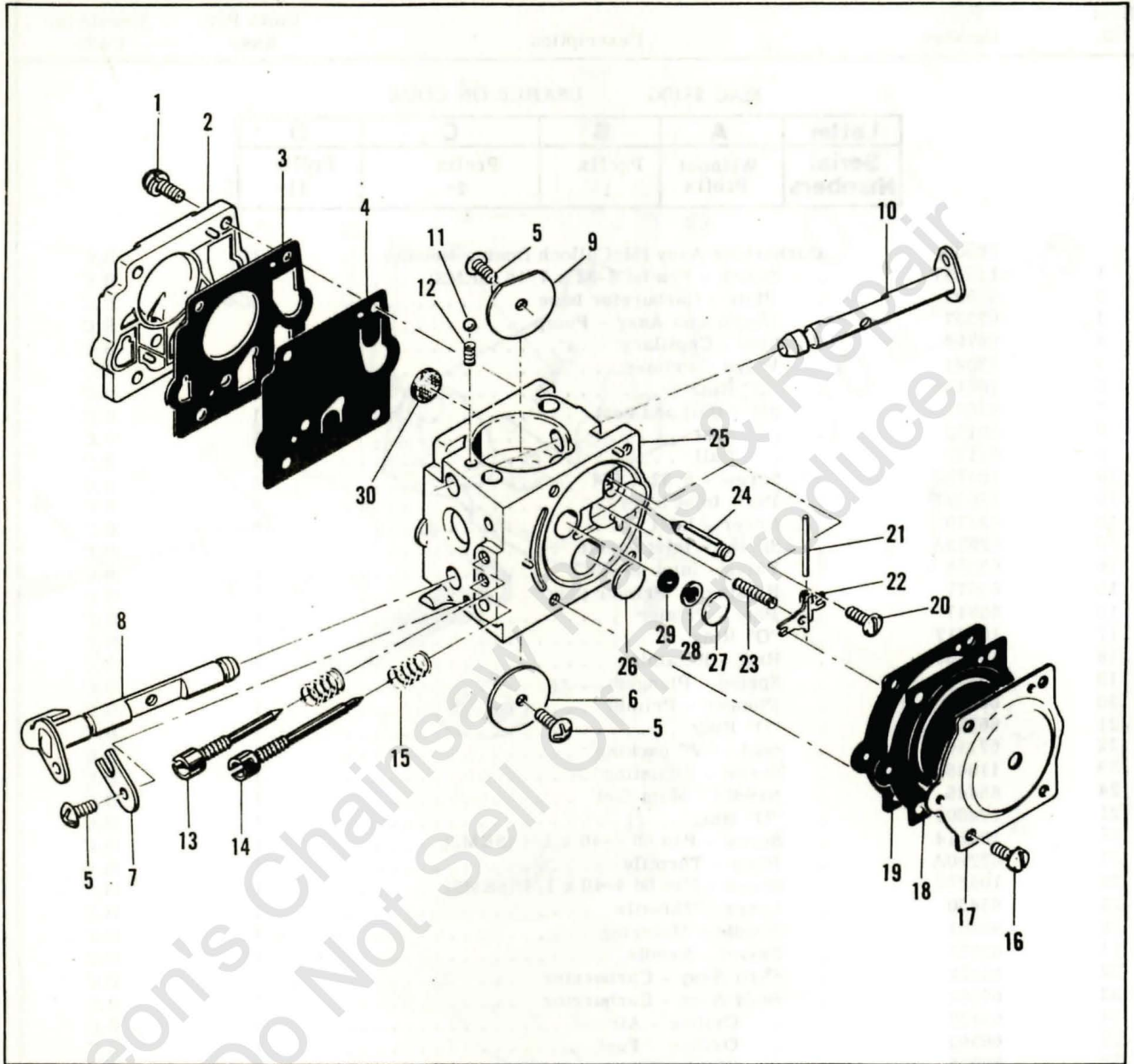

Figure 6 Carburetor Assembly

**MODEL
2-10G**



-Figure 7 Carburetor Assembly

Figure 7. Carburetor Assembly

Item No.	Part Number	Description	Units Per Assy	Usable on Code	
		MAC 2-10G USABLE ON CODE			
	Letter	A	B	C	D
	Serial Numbers	Without Prefix	Prefix 1-	Prefix 2-	Prefix 11-
	67379	Carburetor Assy (McCulloch SDC-2)	1		D
1	67501	. Screw - Pump cover	4		D
2	83760	. Cover - Pump	1		D
3	*67495	. Gasket - Cover	1		D
4	*83114	. Diaphragm - Fuel pump	1		D
5	*47690	. Screw - Plate	3		D
6	67487	. Plate - Throttle	1		D
7	67489	. Clip - Shaft	1		D
8	67486	. Shaft Assy - Throttle	1		D
9	67490	. Plate - Choke	1		D
10	67488	. Shaft Assy - Choke	1		D
11	*100302	. Ball - Choke friction	1		D
12	*67504	. Spring - Choke	1		D
13	*67506	. Needle - High speed	1		D
14	*67505	. Needle - Idle	1		D
15	*67502	. Spring - Needle	2		D
16	70798	. Screw - Diaphragm cover	4		D
17	83761	. Cover - Diaphragm	1		D
18	*67499	. Diaphragm - Metering	1		D
19	*67496	. Gasket - Diaphragm	1		D
20	*67500	. Screw - Lever pin	1		D
21	*67508	. Pin - Lever	1		D
22	*67509	. Lever - Metering	1		D
23	*67503	. Spring - Lever	1		D
24	*67491	. Valve - Needle	1		D
25	67483	. Body Assy - Carburetor	1		D
26	*71690	. Plug - 3/8	1		D
27	*69506	. Plug - 5/16	1		D
28	69203	. Seat Assy	1		D
29	69204	. Valve	1		D
30	*67507	. Screen - Fuel	1		D
	*67482	Gasket Set			D
	67481	Repair Kit			D

*Indicates parts included in Repair Kit, P/N 67481

McCULLOCH SDC-2 CARBURETOR ADJUSTMENT

- Carefully turn both the high speed and idle needles clockwise until resistance is felt, then turn both needles counterclockwise one full turn.
- With engine warmed up, adjust the idle speed screw in or out until the engine idles just below clutch engagement speed.
- Adjust the idle mixture needle in or out (leaner or richer) to obtain smooth, rapid acceleration every time without faltering. If necessary, readjust the idle speed screw.
- Adjust the high speed mixture needle for maximum power under load. Turn the needle in for leaner and out for richer mixture. Do not use any leaner setting than necessary to obtain smooth, even running when cutting wood.

MODEL 2-10G

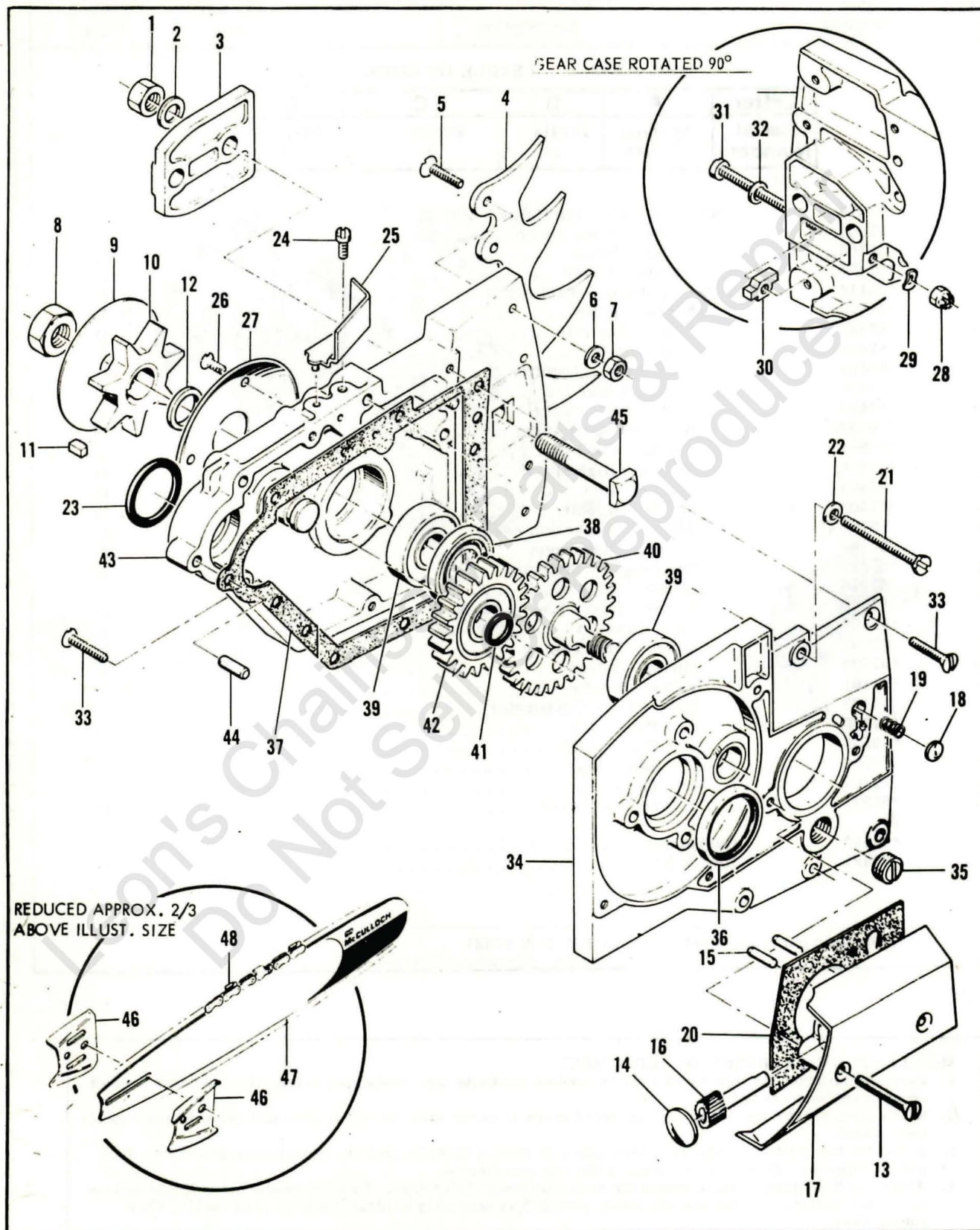

Figure 8 Transmission Assembly

Figure 8. Transmission Assembly

Item No.	Part Number	Description	Units Per Assy	Usable on Code															
<table border="1" style="margin: auto;"> <tr> <td colspan="2" style="text-align: center;">MAC 2-10G</td> <td colspan="3" style="text-align: center;">USABLE ON CODE</td> </tr> <tr> <th style="text-align: center;">Letter</th> <th style="text-align: center;">A</th> <th style="text-align: center;">B</th> <th style="text-align: center;">C</th> <th style="text-align: center;">D</th> </tr> <tr> <th style="text-align: center;">Serial Numbers</th> <th style="text-align: center;">Without Prefix</th> <th style="text-align: center;">Prefix 1-</th> <th style="text-align: center;">Prefix 2-</th> <th style="text-align: center;">Prefix 11-</th> </tr> </table>					MAC 2-10G		USABLE ON CODE			Letter	A	B	C	D	Serial Numbers	Without Prefix	Prefix 1-	Prefix 2-	Prefix 11-
MAC 2-10G		USABLE ON CODE																	
Letter	A	B	C	D															
Serial Numbers	Without Prefix	Prefix 1-	Prefix 2-	Prefix 11-															
1	110625	Nut - Hex hd 3/8-24	2	All															
2	100006	Washer - 3/8	2	All															
3	63417	Plate - Bar clamp	1	All															
4	63994	Kit - Spike	1	All															
5	110245	. Screw - Fl hd 10-24 x 3/4	4	All															
6	101174	. Washer - #10	4	All															
7	101191	. Nut - Hex 10-24	4	All															
8	60972	Nut - Hex 7/16-20	1	All															
9	63997A	Plate - Sprocket	1	All															
10	36644A	Sprocket	1	All															
11	63808	Key - Sprocket	1	All															
12	64754	Spacer - Sprocket	1	All															
13	110406	Screw - Oval hd 8-32 x 1-1/4	2	All															
	65882	Pump Assy - Oil	1	All															
14	105559	. Plug - Welch	1	All															
15	110392	. Pin - Plunger	2	All															
16	63428	. Plunger - Pump	1	All															
17	65881	. Body - Pump	1	All															
18	62909	Valve - Oiler	1	All															
19	63692	Spring - Valve	1	All															
20	63474	Gasket - Pump	1	All															
21	102765	Screw - Hex hd 10-24 x 1-3/4	2	All															
22	100003	Washer - #10	2	All															
	66208	Transmission Assy (3:1 Ratio)	1	All															
23	104360	. "O" Ring	1	All															
24	110055	. Screw - Fil hd 8-32 x 3/8 (SEMS)	1	All															
25	63491	Filler	1	All															
26	110417	. Screw - Fl hd 6-32 x 3/8	3	All															
27	63416	Plate - Sprocket	1	All															
28	102067	. Nut - Hex 10-24	1	All															
29	110387	. Washer - Wave	1	All															
30	63824A	. Nut - Bar adjustment	1	All															
31	102144	. Screw - Bar adjustment	1	All															
32	101174	. Washer - #10	1	All															
33	110405	. Screw - Oval hd 8-32 x 7/8	6	All															
34	64779	. Cover Assy - Gearcase	1	All															
35	100432	. Plug - Filler	1	All															
36	63477	. Seal - Pinion gear	1	All															
37	63433	. Gasket - Cover	1	All															
38	63478	. Seal - Gearcase	1	All															
39	110348	. Bearing - Sprocket shaft	2	All															
40	64775	. Gear - Sprocket	1	All															
41	110452	. "O" Ring	1	All															
42	66616	. Gear Assy - Idler	1	All															
43	64770	. Gearcase	1	All															
44	101770	. Pin - Dowel	2	All															
45	64584	. Bolt - Bar	2	All															
46	64935	Plate - Bar protector	2	All															
47		Bar	1	All															
48		Chain Assy	1	All															

MODEL 2-10G

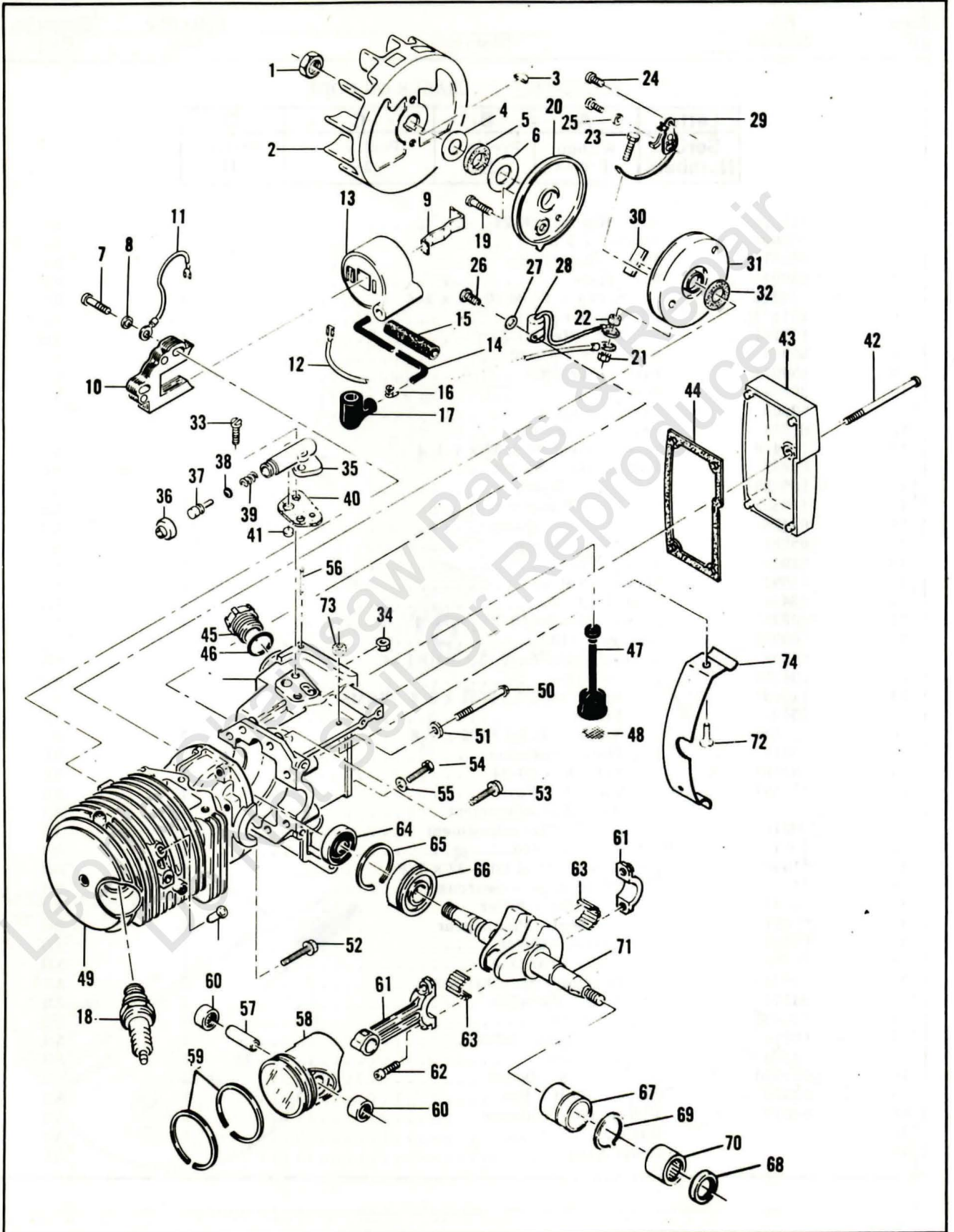

Figure 9 Powerhead Assembly

Figure 9. Powerhead Assembly

Item No.	Part Number	Description	Units Per Assy	- Usable on Code		
		MAC 2-10G USABLE ON CODE				
		Letter	A	B	C	D
		Serial Numbers	Without Prefix	Prefix 1-	Prefix 2-	Prefix 11-
1	101391	Nut - Hex 3/8-24	1			All
2	61737A	Flywheel Assy	1			All
3	103879	Key - Woodruff	1			All
4	67057	Washer - Thrust	1			D
5	67056	Seal	1			D
6	67054	Washer - Thrust	1			D
7	110127	Screw - Fil hd 10-24 x 7, 8 (SEMS)	2			All
8	100003	Washer - #10	2			All
9	51253	Retainer - Coil	1			All
10	68164	Lamination Assy	1			All
11	62819	Wire Assy - Ground	1			All
12	69344	Wire Assy - Primary	1			All
13	69798	Coil and Terminal Assy	1			All
14	69966	Wire Assy - Spark plug	1			All
15	67127	Sleeve	1			All
16	62932	Connector	1			All
17	62926	Boot	1			All
18	63097	Spark Plug	1			All
19	110349	Screw - Rd hd 8-32 x 3, 4	1			All
20	62362	Cover - Breaker box	1			All
21	100298	Nut - Hex 6-32	1			All
22	62365	Spacer - Breaker screw	1			All
23	110346	Screw - Hex hd 6-32 x 3/4	1			All
24	100934	Screw - Rd hd 8-32 x 3, 8	1			All
25	105976	Washer - #8	1			All
26	105249	Screw - Rd hd 8-32 x 3, 8 (SEMS)	1			All
27	100080	Washer - #8	1			All
28	61650	Condenser	1			All
29	62363	Breaker Assy	1			All
30	54184	Wiper - Cam	1			All
31	62361	Box - Breaker	1			All
32	67051	Seal - Box	1			D
33	110623	Screw - Fil hd 8-32 x 1, 2	2			All
34	100955	Nut - Hex 8-32	1			All
35	62261A	Housing - Pump	1			All
36	62262	Cap - Housing	1			All
37	62266	Plunger - Pump	1			All
38	101056	"O" Ring	1			All
39	66687	Spring - Plunger	1			All
40	62230	Gasket - Pump	1			All
41	62909	Valve - Pump	1			All
42	110407	Screw - Pan hd 10-24 x 3-1/2	1			All
43	63974	Cover - Oil tank	1			All
44	63442	Gasket --Cover	1			All
45	57129A	Cap - Oil	1			All
46	101148	"O" Ring	1			All
47	62123B	Hose Assy - Oil	1			All
48	51506	Screen - Hose	1			All
49	67121	Crankcase Assy	1			All
50	62105	Screw Assy - Sealing	4			All
51	62842	Washer - Sealing	4			All
52	110404	Screw Assy - Hex hd 8-32 x 7/8	1			All
53	110288	Screw Assy - Hex hd 8-32 x 3/4	2			All

**MODEL
2-10G**

Figure 9. Powerhead Assembly (Continued)

Item No.	Part Number	Description	Units Per Assy	Usable on Code
54	63607	. Screw Assy - Sealing	1	All
55	63606	. Washer - Sealing	1	All
56	100010	. Pin - Cotter	1	All
57	61649	Pin - Piston	1	All
58	69212	Piston Assy	1	All
59	62814	. Ring Set - Piston	1	All
60	103512	. Bearing - Needle	2	All
61	65401	Connecting Rod Assy	1	All
62	61627A	. Screw - Skt hd 8-36 x 1.2	2	All
63	63225	. Roller - Needle (Set of 20)	1	All
64	65746	Oil Seal	1	All
65	63464	Ring - Snap	1	All
66	63429B	Bearing - Ball	1	All
67	63492	Insert and Bearing Assy	1	All
68	65747	. Oil Seal	1	All
69	63699	. Ring - Insert	1	All
70	104357	. Bearing - Needle	1	All
71	68505	Crankshaft	1	All
72	105221	Screw - Rd hd 10-24 x 5 16	2	All
73	101191	Nut - Hex 10-24	2	All
74	65363	Guard - Crankcase	1	All

Accessories

Item No.	Part Number	Description	Units Per Assy	Usable on Code
	61040	Wrench - Screwdriver		
	65712	Guide - Timing		
	67067	Kit - Gearcase brace		
	68052	Plate - Wear		
	65325	Baffle - Spark arrester		
	63432	Spark Plug - AC CS 42T		
	65778	Spark Plug - AC CS 41T		
	69210	Piston Assy - 0.020 in. oversize		
	62813	. Ring Set - Piston 0.020 in. oversize		
	103512	. Bearing - Needle (2)		
	69211	Piston Assy - 0.030 in. oversize		
	62812	. Ring Set - Piston 0.030 in. oversize		
	103512	. Bearing - Needle (2)		

**40:1 TWO-CYCLE
MOTOR OIL**



6 oz. can # 78960
6-pack # 78961
16 oz. can # 78963
6-pack # 78964
1 qt. bottle # 110626

Reduces smoke,
carbon and engine wear.

**CHAIN, BAR AND
SPROCKET OIL**



1 qt. bottle # 110631
Case of 24 # 110632

Specially designed for
extra lubrication of bars
and chains.

BAR GUARDS

Protect bar and chain
from accidental
damage.



A



B

Black Polyvinylchloride

(A) for wide bars # 56927

(B) narrow bars # 64930



C



D

Rigid Yellow Plastic

(C) MAC 10 - 16, 20" # 66544

(D) PM6 - 12, 16" # 83124

LOCQUIC AND

Primer. Cleans,
degreases, and
accelerates curing.

7-1/2 oz. spray can.
69794



LOCTITE

Sealant, bonding
agent

10cc plastic
bottle
67537



SPRAY PAINT

Black

12 oz. can # 103503
Case of 12 # 103400



Yellow

12 oz. can # 102249
Case of 12 # 102464

STARTER ROPE

Solid, braided nylon



100' spool

36825







PRESSURE TEST TOOLS

For leakage check
of crankcase,
fuel system.



Basic unit
62849

CHAIN SHARPENING TOOLS

The ● shows which tools are used on chains		S-25	SM-37	S-40	S-80	S-90
 <p>McCULLOCH FILES</p>	1/8" round	●				
	5/32" round	●	●			
	3/16" round		●			
	7/32" round			●		
	1/4" round				●	
	9/32" round					●
8" flat	●	●	●	●	●	
6" flat safety	●	●	●	●	●	
FILE GUIDE & FILE						
	# 67750 (1/8" round)	●				
	# 60950 (7/32" round)			●		
	(Also holds 3/16 and 1/4" round)		●		●	
DEPTH GAUGE TOOLS						
	# 56241 .045-.060"				●	●
	# 64198 .035-.060"				●	●
	# 64359 .045-.050"				●	●
	# 67688 .015-.020"	●				
	# 67680 .025-.030"	●	●	●	●	●
FILE-N-JOINT Assures correct filing angle, height.						
	# 61034	●	●	●	●	●
GEAR OIL (SAE 140)						
For transmissions of gear drive saws.						
	16 oz. can # 19342					
	Case of 24 # 104347					
"BREAK ALL" CHAIN BREAKER						
Required when repairing chain.						
	# 61753					
	Instructions included.					

 **McCULLOCH**
CORPORATION



● MANUFACTURING ● SALES ● SERVICE ●

McCULLOCH
CORPORATION

P.O. Box 92180, Los Angeles, CA 90009

Copyright - McCulloch.

**FOR SERVICE-RELATED PROBLEMS,
REPAIR OR MAINTENANCE
TAKE YOUR UNIT TO THE NEAREST
AUTHORIZED McCULLOCH SERVICING
DEALER LISTED IN YOUR
TELEPHONE DIRECTORY YELLOW PAGES.**

If additional assistance is required, call this toll-free hot-line:
(800) 423-6302

Arizona residents call collect (602) 453-3681