

ILLUSTRATED PARTS LIST

MODELS	SERIAL NUMBER PREFIX	MODELS	SERIAL NUMBER PREFIX
600017B	11-	600016G	14-
600017C	11-	600017U	11-
600017F	11-		

McCulloch chain saws are identified by a model number (in this instance, 600017) followed by a suffix letter (A, B, C, etc.) stamped on the identification plate attached to the saw. Suffix letters denote variations in parts or assemblies in the manufacture of the saw.

Part numbers listed in this I.P.L. which have a suffix letter or letters following the description, indicate the part is used only on the model(s) identified by the letter or letters.

Part numbers and descriptions without suffix letter or letters apply to all versions of the chain saw model.

Part numbers which have one or more dots (.) preceding their descriptions may be ordered individually, but they are also included in the kit or assembly whose description begins directly above the dot(s).

Part numbers in this IPL which were not in the previous IPL covering these saws, are indicated by a dash (-) preceding the new part number.

The policy of McCulloch Corporation is one of continual improvement in design, manufacturing and engineering advancement wherever possible to assure still finer two-cycle power tools. Hence, specifications, equipment, colors, design and manufacturer's suggested list prices are subject to change without notice and McCulloch Corporation reserves the right to make such changes without prior notification or obligation to backfit or supply backfit components for units previously shipped from the factory.

MAC 130 CHAIN SAW



March 1982

- CONTENTS -

	Page
Figure 1. General	2
Figure 2. Carburetor Assembly	4
Figure 3. Carburetor Assembly	5
Figure 4. Powerhead Assembly	6
Figure 5. CHAIN BRAKE Assembly	8
Service Specifications	3
Tools and Accessories	8



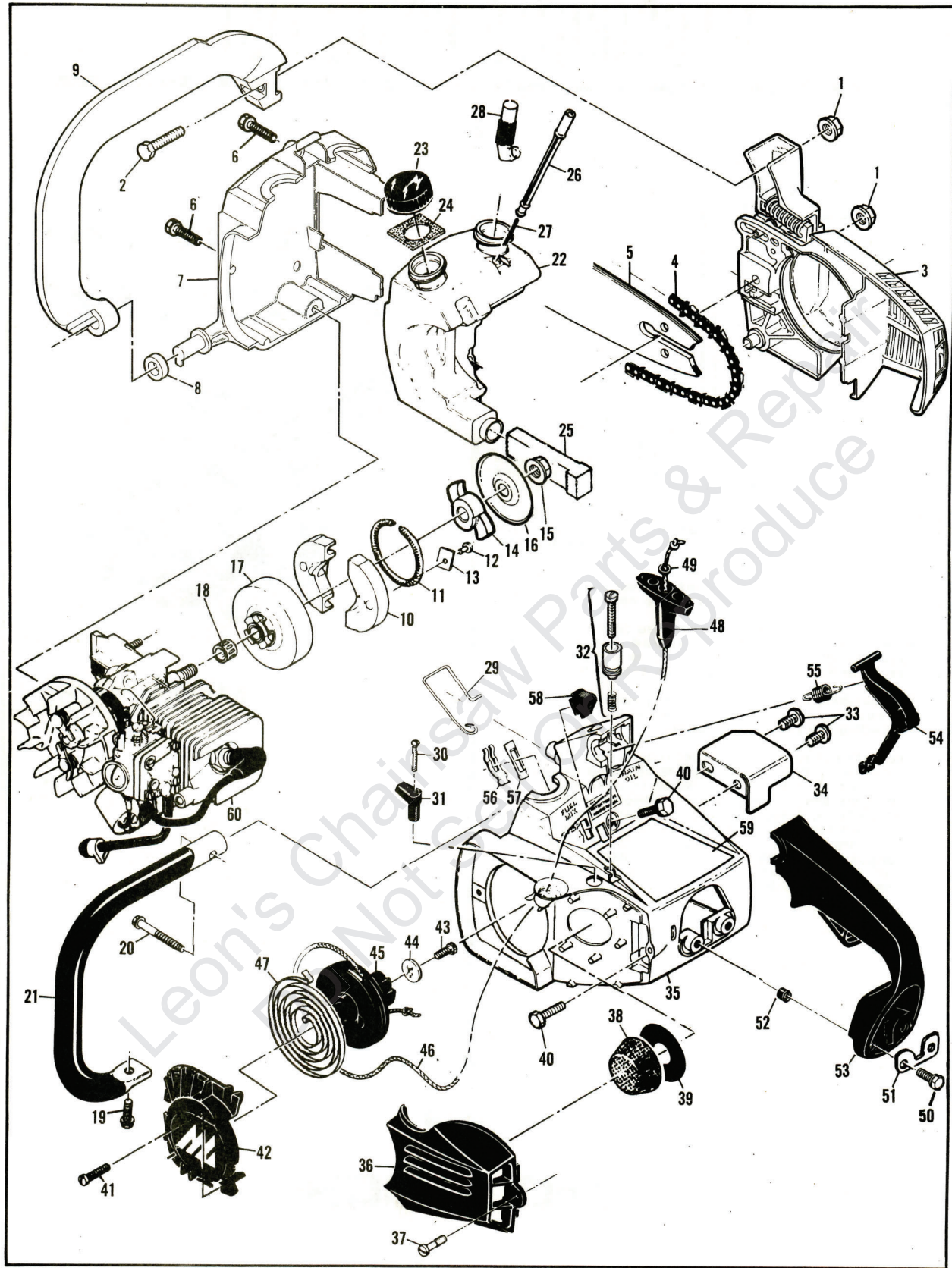

Figure 1. General

Figure 1. General.

ITEM NO.	PART NUMBER	DESCRIPTION	UNITS PER ASY.
1	110676	Nut - Hx 1/4-28	2
2	110972	Screw - Hx 1/4-28 x 3/4	1
3	--	CHAIN BRAKE Assy (Fig. 5)	
4	--	Chain Assy (See below)	
5	--	Bar (See below)	
6	110639	Screw - Hx hd 12-24 x 1	2
7	92868A	Cover - Fuel & Oil tank	1
8	93194A	Washer - Rubber	1
9	92479	Lever - Handguard	1
10	213278	① Kit - Clutch	1
10	213277	② . Clutch Assembly	1
11	93608	. . Spring Assembly	1
12	110957	. . Rivet	2
13	85064	. . Plate	2
14	94242	② . Rotor	1
14	94247	① . Kit - Rotor	1
15	94244	② . . Nut - Clutch	1
16	94243	② . . Plate - Dust	1
17	95197	Drum/Spkt/Brng Assembly	1
18	91222	. Kit - Needle bearing	1
19	110953	Screw - Hx hd 12-24 x 5/8	1
20	110686	Screw - Hx hd 13-16 x 2	1
21	214505	Frame & Grip Assembly	1
22	91454A	Kit - Fuel & oil tank	1
23	91283	. Cap - Fuel & oil (unvented)	2
24	91148	. Seal - Fuel vent	1
25	84956	. Pickup - Fuel	1
26	83900A	. Piston - Manual oiler	1
27	83946	. Spring - Piston	1
28	85557	. Body - Oiler	1
29	84611	Rod - Manual oiler	1
30	110672	Screw - Oval hd 4-40 x 1	1

ITEM NO.	PART NUMBER	DESCRIPTION	UNITS PER ASY.
31	83870	Knob - Choke	1
32	--	Throttle Latch Assy (Fig. 3, 4)	1
33	110807	Screw - Pan hd 8-32 x 5/16	2
34	93290	Deflector - Sawdust	1
35	214270	Shroud	1
36	91853	Cover - Air cleaner	1
37	91796	. Screw - Air cleaner	1
38	91460	Filter - Air	1
39	84918	Washer - Air seal	1
40	110953	Screw - Hx hd 12-24 x 5/8	3
41	110959	Screw - Hx hd 8-32 x 1/2	3
42	90425	Cover - Starter	1
43	110041	Screw - Pan hd 8-32 x 1/2	1
44	68497	Washer - Special	1
45	213261	Drum/Rope Assembly	1
46	83203	. Rope - Starter	1
47	83078	Spring - Rewind	1
48	91255	Kit - Starter handle	1
49	105490	. Washer - Starter handle	1
50	110953	Screw - Hx hd 12-24 x 5/8	2
51	84520A	Plate - Washer	1
52	84519	Sleeve - Handle	2
53	93810	Kit - Handle	1
54	93869	. Trigger - Throttle	1
55	83940	Spring - Trigger	1
56	83935	Contact - Switch	1
57	83936	Protector - Switch	1
58	83934	Button - Switch	1
59	-93542	Plate - Name	1
60	--	Powerhead Assembly (Fig. 4)	1

① Used on models with serial number prefix 11-.

② Used on models with serial number prefix 14-.

Service Specifications

Displacement	2.0 cu. in.
Bore and Stroke	1.430 x 1.201 in. (36.5 x 30.5 mm)
Bearings	Main: Needle Conn. Rod: Needle
Intake System	3rd Port, Piston Timed
Fuel Tank Capacity	10.8 fl. oz. (320 cc)
Chain Oiler Capacity	3.2 fl. oz. (95 cc)
Clutch Engaging Speed	3800 to 4200 rpm
Idle Speed	2700 to 2900 rpm
Ignition	Magneto

Carburetor	Diaphragm Type, 2 needle
Fuel Type	Regular grade, leaded
Fuel/Oil Mixture	40:1 w/ McCulloch Oil
Filter System - Fuel	Felt Fuel Filter
Filter System - Air	Flocked Screen Filter
Lamination Gap008 to .012" (.203 to .304 mm)
Breaker Point Gap018" (.457 mm)
Timing	26° B.T.D.C.
Piston Rings	2 Cast Iron Compression
Weight (w/ bar & chain)	9.7 lbs. (4.4 kg)

Figure 2. Carburetor Assembly.

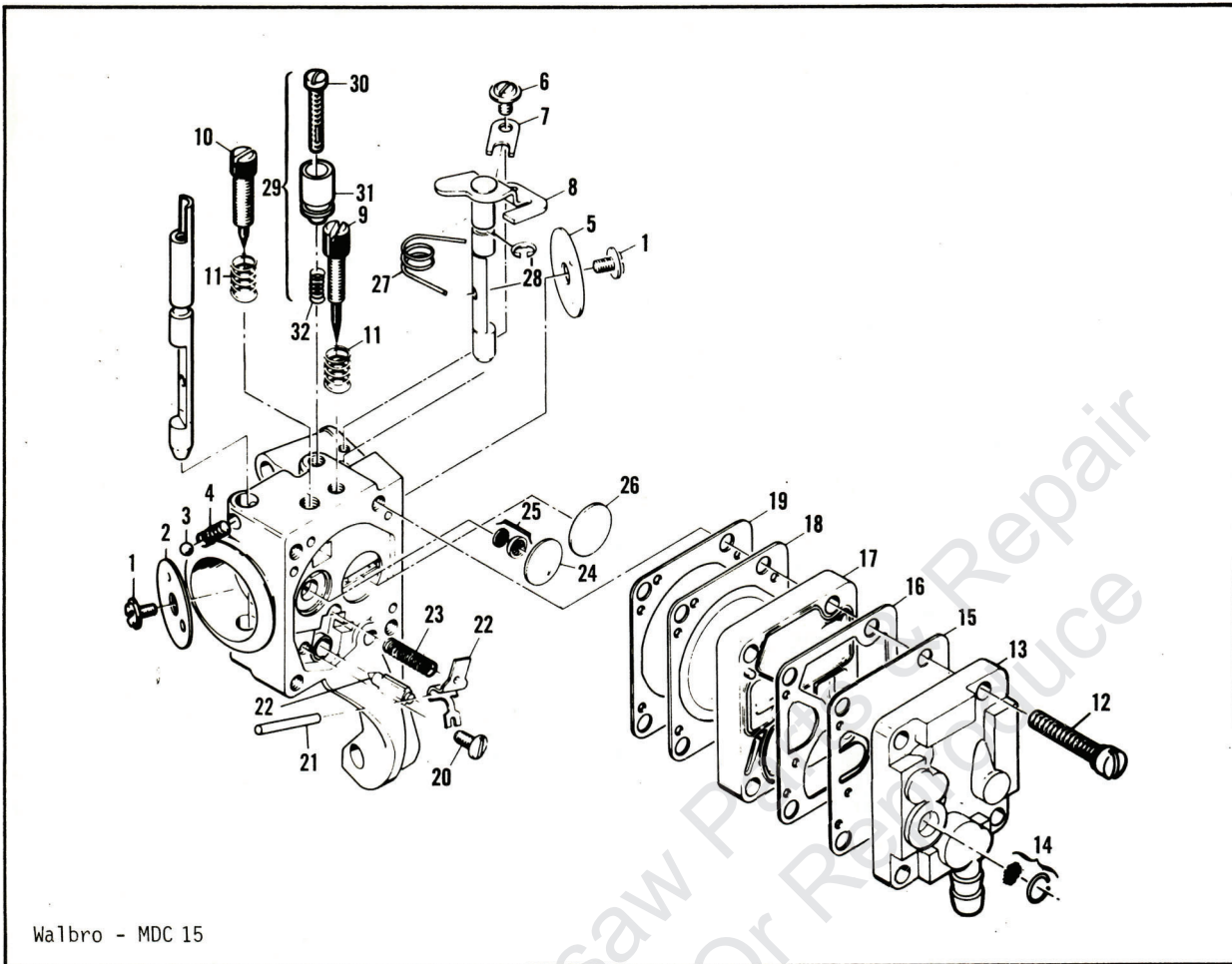

ITEM NO.	PART NUMBER	DESCRIPTION	UNITS PER ASY.
	214082	① Carburetor Asy - Walbro MDC 15	1
1	83755	② . Screw - Plate	2
2	68556	. Plate - Choke	1
3	100302	② . Ball - Choke friction	1
4	67504	② . Spring - Choke friction	1
5	68553	. Plate - Throttle	1
6	70798	. Screw - Clip	1
7	68554	. Clip - Throttle shaft	1
8	94138	② . Shaft Asy - Throttle	1
9	86446	② . Needle - Idle	1
10	86447	② . Needle - High speed	1
11	67502	② . Spring - Needle	2
12	68564	. Screw Asy - Body	4
13	91347	. Cover Asy - Pump	1
14	85629	② . . Kit - Vent screen	1
15	68563	② . Diaphragm - Fuel pump	1
16	85035	. Gasket - Pump diaphragm	1

ITEM NO.	PART NUMBER	DESCRIPTION	UNITS PER ASY.
17	85030	② . Body - Fuel pump	1
18	85036	② . Diaphragm - Metering	1
19	85034	② . Gasket - Diaphragm	1
20	67500	② . Screw - Lever pin	1
21	67508	. Pin - Lever	1
22	85059	② . Kit - Needle & Lever	1
23	68567	② . Spring - Lever	1
24	68559	② . Plug - Welsh 7/16	1
25	83758	② . Kit - Check valve	1
26	68560	. Plug - Welsh 1/2	1
27	89785	. Spring - Throttle return	1
28	94139	. Ring - Retaining	1
29	93437	Latch Asy - Throttle	1
30	-	. Screw - Long lock	1
31	-	. Latch - Throttle	1
32	-	. Spring - Compression	1
	86463	- Repair Kit	1

① One of two carburetors used. Identify parts before ordering.

② Included in Repair Kit, P/N 86463.

Part numbers which have one or more dots (.) preceding their descriptions may be ordered individually, but they are also included in the kit or assembly whose description begins directly above the dot(s).

Figure 3. Carburetor Assembly.

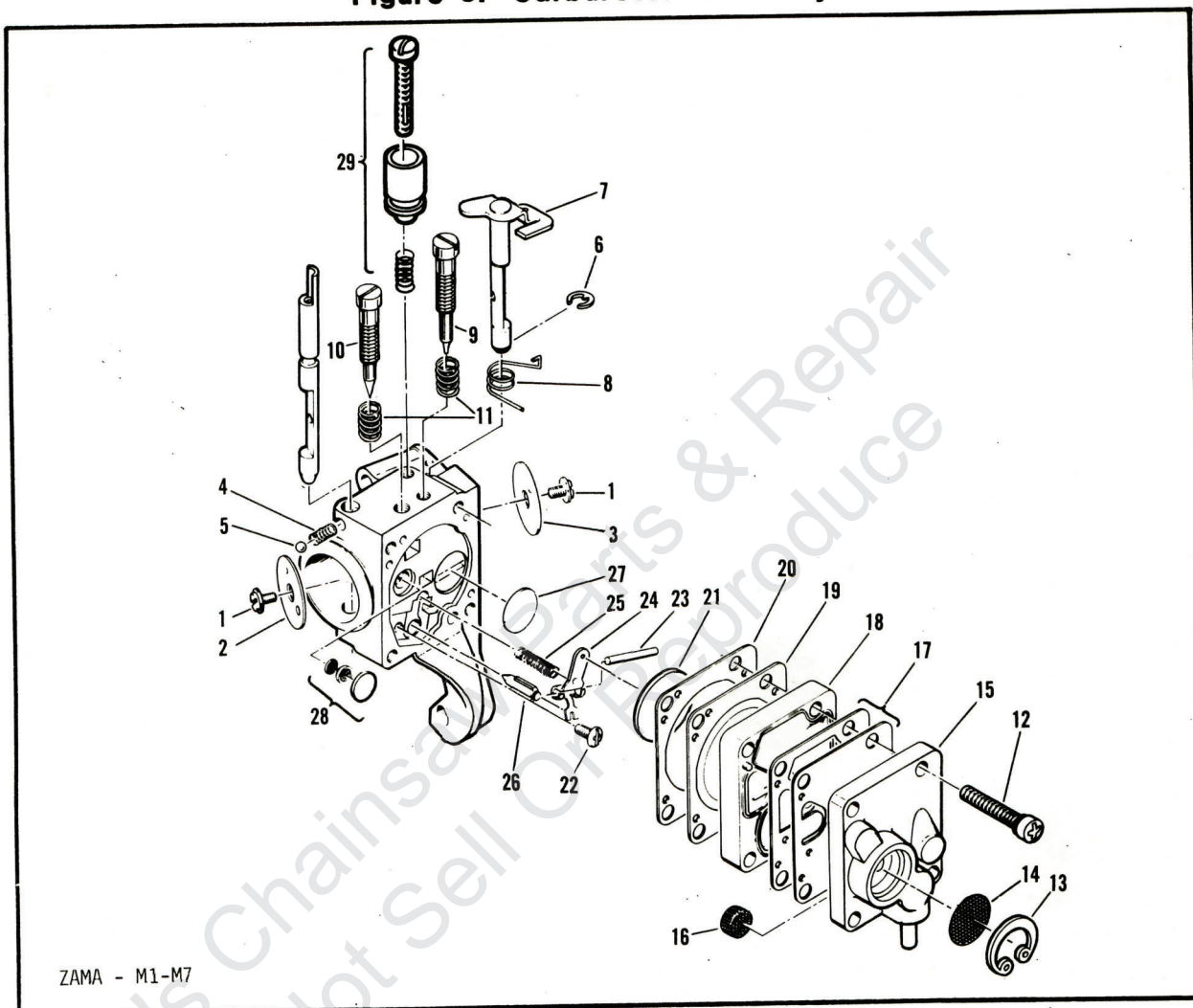

ZAMA - M1-M7

ITEM NO.	PART NUMBER	DESCRIPTION	UNITS PER ASY.
	-214082A	① Carburetor Asy - Zama M1-M7	1
1	91804	. Screw - Plate	2
2	-215274	. Valve - Choke	1
3	91803	. Valve - Throttle	1
4	93955	. Spring - Choke	1
5	93956	. Ball - Friction	1
6	91805	. "E" Ring	1
7	-215291	. Shaft Assembly - Throttle	1
8	-215286	. Spring - Throttle return	1
9	-215275	② . Screw - Idle adjustment	1
10	-215276	② . Screw - Main adjustment	1
11	91819	② . Spring - Screw	2
12	-215279	. Screw - Cover	4
13	-215283	. "C" Ring	1
14	-215284	. Strainer	1

ITEM NO.	PART NUMBER	DESCRIPTION	UNITS PER ASY.
15	-215285	. Cover - Pump	1
16	91820	② . Screen	1
17	-	② . Kit - Pump diaphragm	1
18	-215281	. Body - Pump	1
19	-215282	② . Diaphragm - Main	1
20	-215280	② . Gasket - Main	1
21	-215277	② . Disk	1
22	91814	② . Screw	1
23	91813	② . Pin - Arm	1
24	-215278	② . Arm - Needle valve	1
25	91811	② . Spring - Arm	1
26	91810	② . Valve - Needle	1
27	93951	. Plug - Welsh	1
28	-215287	② . Valve Asy - Main nozzle	1
29	93437	Latch Assembly - Throttle	1
	-215292	Repair Kit	

- ① One of two carburetors used. Identify parts before ordering.
- ② Contained in Repair Kit, P/N 215292.

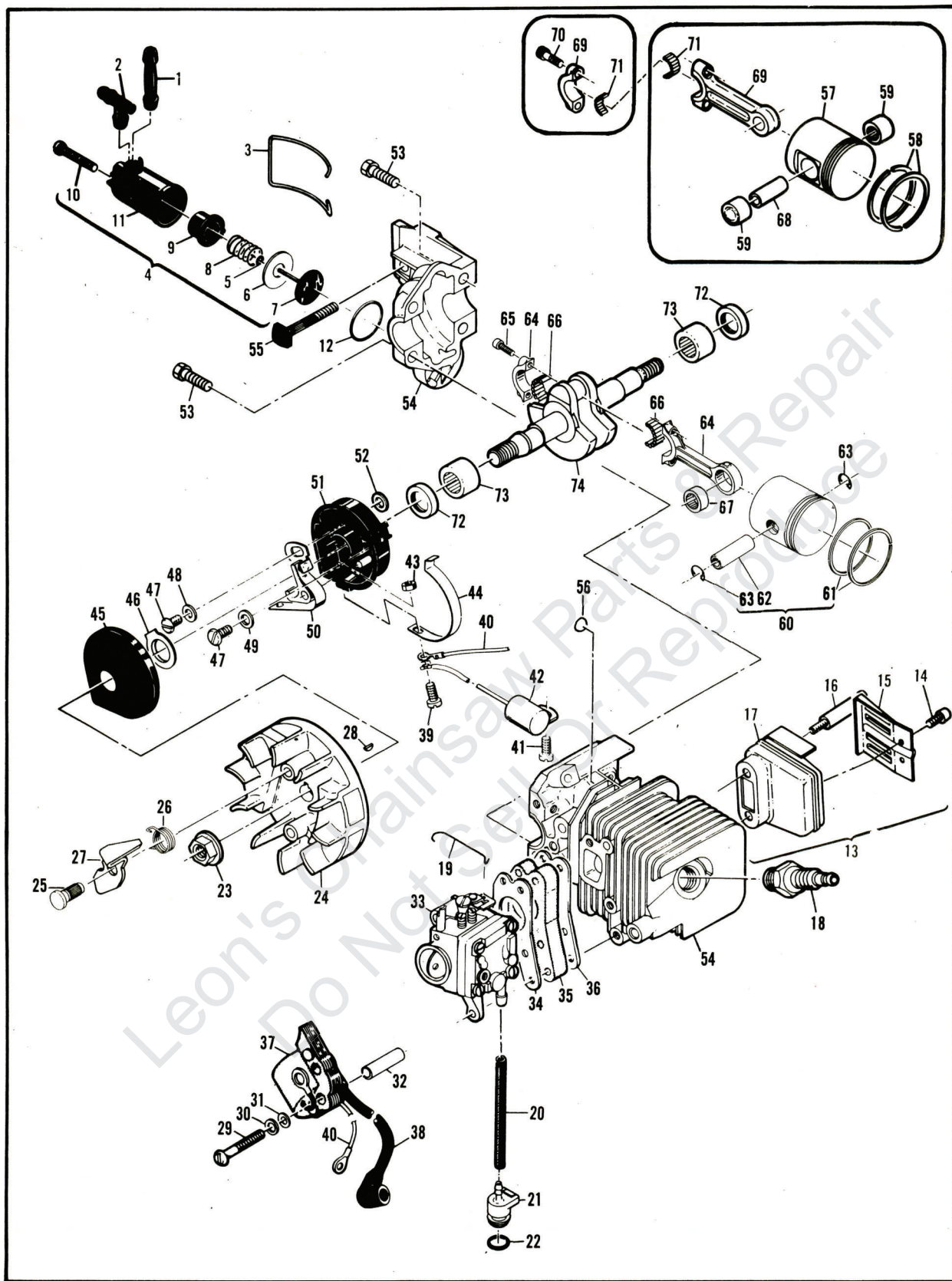

Figure 4. Powerhead Assembly.

Figure 4. Powerhead Assembly.

ITEM NO.	PART NUMBER	DESCRIPTION	UNITS PER ASY.	ITEM NO.	PART NUMBER	DESCRIPTION	UNITS PER ASY.
1	83898	Connector - Outlet	1	35	90713	Insulator - Carburetor	1
2	84613	Connector - Pump	1	36	90714	Gasket - Insulator	1
3	83896	Bail - Mounting	1	37	84957	Coil & Lamination Assembly	1
4	83886	Pump Assembly - Oiler	1	38	50120	. Wire Assembly - Spark plug	1
5	105603	. "O" Ring	1	39	110617	Screw - Pan hd 6-32 x 5/8	1
6	85769	. Ring - Pump piston	1	40	69344	Wire Assembly - Coil	1
7	92204	. Piston Assembly - Pump	1	41	110041	Screw - Pan hd 8-32 x 1/2 s/t	1
8	83891	. Spring - Pump	1	42	85358	Condenser	1
9	83890	. Sleeve - Pump	1	43	-100035	Nut - Hx 6-32	1
10	110651	. Screw - Adjustment	1	44	84502	Connector - Stop switch	1
11	83887	. Body Assembly - Pump	1	45	67841	Cover - Breaker box	1
12	110653	"O" Ring	1	46	69323	Seal - Breaker box	1
13	-214746	① Kit - Muffler	1	47	110969	Screw - Hx hd 8-32 x 1/2	2
14	-110681	① . Screw - Skt hd 10-24 x 1/4	2	48	69322	Washer - Special	1
15	-92961	① . Deflector - Exhaust	1	49	105976	Washer - #8	1
16	-213327	① . Screw - Special	2	50	88811	Breaker Assembly	1
17	-213346	① . Body - Cover	1	51	84505A	Kit - Breaker box	1
13	92962	② Kit - Muffler	1	52	92037	. Washer	1
14	110681	② . Screw - Skt hd 10-24 x 1/4	2	53	110639	Screw - Hx hd 12-24 x 1	4
15	92961	② . Deflector - Exhaust	1	54	-214157	① Kit - Cyl/C'case Assembly	1
16	93036	② . Screw - Special	2	55	83856	① . Bolt - Bar mounting	1
17	93655	② . Body - Cover	1	56	110914	① . Plug - Cup	4
18	63097	Spark Plug (F,G,J,K,P,S,U)	1	54	-214164	② Cyl/C'case Assembly	1
18	93018	Spark Plug (B,E,H)	1	55	83 56	② . Bolt - Bar mounting	1
19	89274	Rod - Throttle	1	56	110914	② . Plug - Cup	4
20	89159	Hose - Fuel	1	57	68098	② Piston Assembly	1
21	90660	Adaptor - Fuel hose	1	58	87165	② . Set - Piston rings	1
22	110908	"O" Ring	1	59	110538	② . Bearing - Needle	2
23	110970	Nut - Hx 5/16-24	1	60	94662	① Piston Assembly	1
24	94513	③ Flywheel/Pawl Assembly	1	61	95143	① . Set - Piston rings	1
25	68796	③ . Pin - Pawl	2	62	92836	① . Pin - Piston	1
26	67814	③ . Spring - Pawl	2	63	111026	① . Ring - Snap	2
27	94493	③ . Pawl - Starter	2	64	94135	① Connecting Rod Assembly	1
24	91961	④ Flywheel/Pawl Assembly	1	65	94654	① . Screw - Connecting rod	2
25	68796	④ . Pin - Pawl	2	66	68095	① . Roller - Needle (Set of 20)	1
26	67814	④ . Spring - Pawl	2	67	110984	① . Bearing - Needle	1
27	91872	④ . Pawl - Starter	2	68	66867	② Pin - Piston	1
28	102164	Key - Woodruff	1	69	68097	② Connecting Rod Assembly	1
29	110586	Screw - Pan hd 8-32 x 1-3/4	3	70	66853	② . Screw - Special	2
30	105976	Washer - #8	3	71	68095	② . Roller - Needle (Set of 20)	1
31	67177	Washer - Insulating	3	72	83859	Seal - Oil	2
32	68198	Tube - Insulating	3	73	-213282	Bearing - Crankshaft	2
33	-	Carburetor Assembly (Fig. 3, 4)	1	74	91932	Crankshaft	1
34	68197	Gasket - Carburetor	1				

* Flywheel nut torque should be 190 to 200 pound x inches (21.5 to 22.6 N.m).

① Used on Models with serial number prefix 14-.

② Used on models with serial number prefix 11-.

③ Used on models with white Drum/Rope Assembly, P/N 94492 (Fig. 1).

④ Used on models with black Drum/Rope Assembly, P/N 92316 (Fig. 1).

Figure 5. CHAIN BRAKE Assembly.

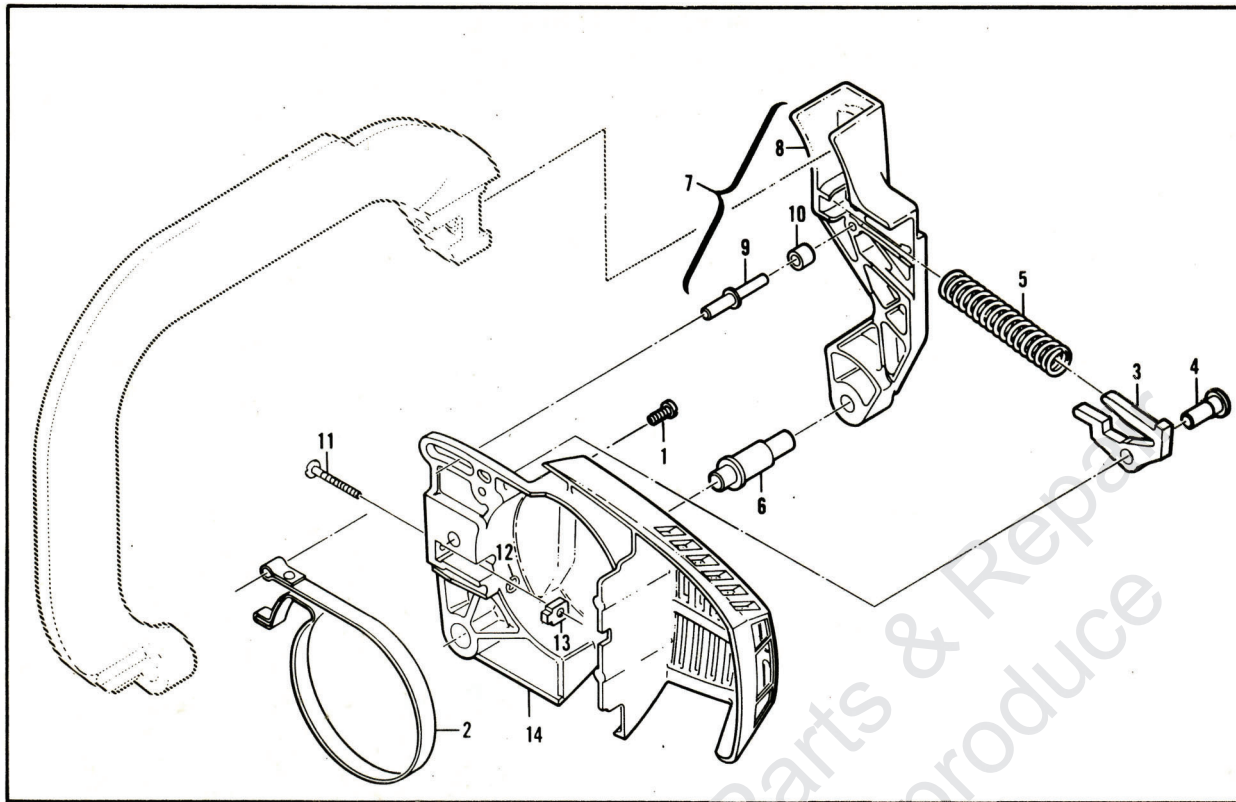

ITEM NO.	PART NUMBER	DESCRIPTION	UNITS PER ASY.
	214376	CHAIN BRAKE Assembly	
1	111047	① . Screw - Pan hd 8-32 x 5/8	1
2	94709	② . Band - Brake	1
2	92487	③ . Band - Brake	1
3	94006	② . Latch	1
3	93092	③ . Latch	1
4	93602	. Pivot - Latch	1
5	94007	② . Spring - Compression	1
5	93140	③ . Spring - Compression	1
6	92482	. Pivot - Lever	1

ITEM NO.	PART NUMBER	DESCRIPTION	UNITS PER ASY.
7	214375	. Lever Assembly - Actuating	1
8	92867	. . Lever	1
9	213907	. . Pin - Roller	1
10	214368	. . Bearing - Roller	1
11	90658	. Screw - Adjusting	1
12	110907	. Ring - Retaining	1
13	84929	. Nut - Bar adjusting	1
14	94175	② . Housing - Brake	1
14	92866	③ . Housing - Brake	1

- ① Not used on some early models.
- ② Used on models with Screw, P/N 111047.
- ③ Used on models without Screw, P/N 111047.

Tools and Accessories

PART NUMBER	DESCRIPTION
95169	Kit - Spark Arrester
91485	Wrench - Socket
85687	Wrench - Screwdriver
88755	Scrench
93283	Case - Carrying, 12"
92976	. Bar Guard, 12"
93090	Guide - Timing
68915A	Kit - Piston Tool
90256	Kit - Tune up
90607A	Guide - File

PART NUMBER	DESCRIPTION
90958A	Kit - Tool Maintenance
93900	Kit - Pressure Test
90533	Tool - Pressure Test
501334	Tester - Ignition
68090	Lubri-Gun
85702	Lubricant - Custom, 6 oz. can
85703	Lubricant - Custom, 6 oz. cans, 1-6 pack
67537	Loctite
69794	Locquic
110083	R.T.V. Sealant