

ILLUSTRATED PARTS LIST

MODEL NAMES McCULLOCH 100 SERIES	
600016-02	17-18
600016-03	17-18
600016-04	17-18
600016-05	17
600016-06	17
600016-07	17-18
600016-08	18
600016-11	17-18
600016-12	17
600016-13	17-18
600016-14	17-18
600016-15	17
600016-17	17
600016-20	17-18
600016-27	18

MODEL NAME McCULLOCH 160 SERIES	
600124-02	12
600124-03	12

MODEL NAME EAGER BEAVER®	
600123-02	11-12
600123-03	11-12
600123-04	- 11-12
600123-05	11-12
600123-06	11-12
600123-07	11-12
600123-08	12
600123-09	12
600123-10	12

MODEL NAME EAGER BEAVER® SUPER 16"	
600124-04	12
600124-06	12
600124-09	12

McCULLOCH 100 SERIES & 160S EAGER BEAVER® & EAGER BEAVER® SUPER 16

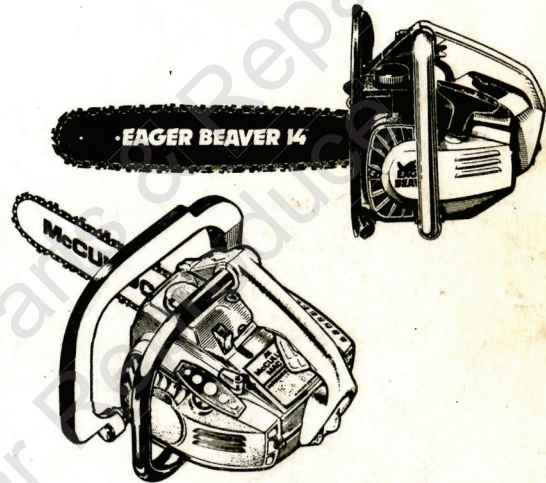

CONTENTS

	PAGE
FIGURE 1 General Assembly	2
FIGURE 2 Service Tools	3
FIGURE 3 Carburetor Assembly (Zama)	4
FIGURE 4 Carburetor Assembly (Walbro)	5
FIGURE 5 Powerhead Assembly	6
FIGURE 6 Chain Brake Assembly	8
FIGURE 7 Specifications	8

Eager Beaver® and McCulloch Chain Saws are identified by a model number (in this instance 600016, 600123, or 600124) followed by a suffix number (02, 03, 04, etc.). Suffix numbers denote variations in parts or assemblies used in the manufacture of this product.

Part numbers listed in this I.P.L. which have a circled number ③ or numbers preceding the description, are used only on the model or models identified by a circled number ③ or numbers.

Part numbers which have one or more dots (.) preceding their descriptions may be ordered individually, but they are also included in the kit or assembly whose description begins directly above the dot(s).

Part number(s) in this IPL which were not in the previous IPL covering these saws, are indicated by a dash (-) preceding the new part number(s).

The policy of McCulloch Corporation is one of continual improvement in design, manufacturing and engineering advancement wherever possible to assure still finer power tools. Hence, specifications, equipment, colors, design and manufacturer's suggested list prices are subject to change without notice and McCulloch Corporation reserves the right to make such changes without prior notification or obligation to backfit or supply backfit components for units previously shipped from the factory.

**FOR SERVICE-RELATED PROBLEMS,
REPAIR OR MAINTENANCE
TAKE YOUR UNIT TO THE NEAREST
AUTHORIZED McCULLOCH SERVICING
DEALER LISTED UNDER SAWS IN YOUR
TELEPHONE DIRECTORY YELLOW PAGES.**

If additional assistance is required, call this toll-free hot-line:
(800) 423-6302
Arizona residents call collect (602) 453-3681

JULY 1988



**McCULLOCH
CORPORATION**

900 Lake Havasu Ave. • Lake Havasu City, AZ 86403-2891

219239-01

Figure 1 GENERAL ASSEMBLY

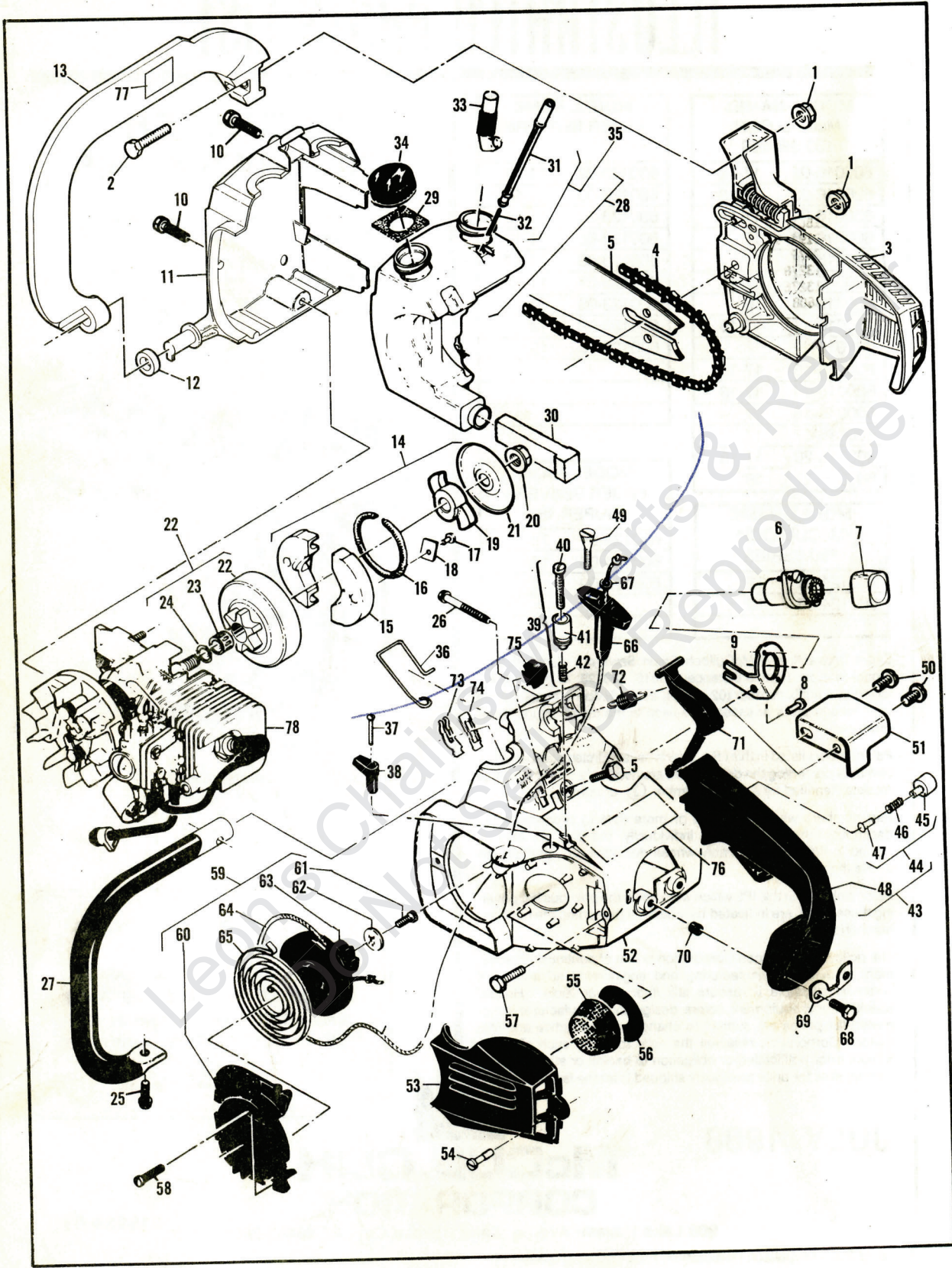

FIGURE 1 GENERAL ASSEMBLY

ITEM NO.	PART NUMBER	DESCRIPTION	UNITS PER ASY.
1	110676	Nut-Hex Head 1/4-28 (65-75 in. lb. torque)	2
2	110972	Screw-Hex 1/4-28x.75	1
3	Fig. 6	Brake Assembly-Chain	1
4	-- --	① Chain-Saw	1
5	-- --	① Bar-Guide	1
6	218886	② Grinder Assembly	1
7	215447	② Knob-Auto Sharp	1
8	110583	② Screw-Pn Hd 8-32x.44 (35-40 in. lb. torque)	2
9	215209	② Bracket-Auto Sharp	1
10	110639	Screw-Hex Hd 12-24x1 (55-60 in. lb. torque)	2
11	218867	Cover-Fuel/Oil Tank	1
12	93194-01	Washer-Rubber	1
13	92479	Lever/Handguard	1
14	213278	Kit-Clutch	1
15	213276	. Shoe-Clutch	2
16	93608	. Spring-Assembly	1
17	-- --	. Rivet-Flt. 1/8x.547	2
18	-- --	. Plate	2
19	-- --	. Rotor	1
20	94244	. Nut-Clutch (160-170 in. lb. torque)	1
21	94243	. Plate-Dust	1
22	215252	Drum/Sprocket/Bearing Assembly	1
23	91222	. Bearing-Needle	1
24	215259	. Spacer-Drum	1
25	110953	Screw-Hx Hd 12-24x.625 (70-80 in. lb. torque)	1
26	110686	Screw-Hx Hd 13-16x2 (35-45 in. lb. torque)	1
27	214505	Frame/Grip Assembly	1
28	217761	Kit-Fuel/Oil Tank	1
29	91148	. Seal-Fuel Vent	1
30	84956	. Pickup-Fuel	1
31	217755	. Piston-Manual Oiler	1
32	83946	. Spring-Piston	1
33	85557	. Body-Oiler	1
34	216668	Cap-Fuel/Oil	2
35	-217762	Rod/Oiler Asy	1
36	217759	. Rod-Manual Oiler	1
31	217755	. Piston-Manual Oiler	1
32	83946	. Spring-Piston	1
37	110672	Screw-Oval Hd 4-40x1	1
38	83870	Knob-Choke	1

ITEM NO.	PART NUMBER	DESCRIPTION	UNITS PER ASY.
39	93437	③ Latch Assembly-Throttle	1
40	216440	. Screw-Throttle Lock	1
41	-- --	. Latch-Throttle	1
42	-- --	. Spring-Compression	1
43	218130	④ Handle/Trigger/Throttle Asy	1
44	-222992	④ ... Kit-Throttle Latch	1
45	-- --	④ ... Knob-Throttle Latch	1
46	-- --	④ ... Spring-Throttle Latch	1
47	-- --	④ ... Rivet-Flat	1
48	217908	③④ . Handle/Safety Trigger Asy	1
49	68566	Screw-Idle Adjustment	1
50	110807	Screw-Pan Hd 8-32x.312 (35-50 in. lb. torque)	2
51	93290	⑤ Deflector-Sawdust	1
52	217015	② Shroud-Using Auto Sharp	1
	216963	Shroud-Non Auto Sharp	1
53	-91853	Cover-Air Filter	1
54	91796	Screw-Filter Cover	1
55	216905	Filter-Air	1
56	84918	Washer-Air Seal	1
57	216490	Screw-Hex Hd 12-24x.76 (70-80 in. lb. torque)	3
58	110959	Screw-Hex Hd 8-32x.50 (25-30 in. lb. torque)	3
59	-213255	Starter Asy	1
60	90425	. Housing-Starter	1
61	110041	. Screw-Pan Hd 8-32x.50 (20-25 in. lb. torque)	1
62	68497	. Washer-Special	1
63	213257	. Drum/Rope Assembly	1
64	83203	. Rope-Starter	1
65	83078	. Spring-Rewind	1
66	91255	Handle Asy-Starter	1
67	105490	. Washer-Starter Handle	1
68	110953	Screw-Hex Hd 12-24x.625 (20-25 in. lb. torque)	2
69	84520-01	Plate-Washer	1
70	84519	Sleeve-Handle	2
71	217909	Trigger-Throttle	1
72	83940	Spring-Trigger Return	1
73	83935	Contact-Switch	1
74	83936	Protector-Switch	1
75	83934	Button-Switch	1
76	218853	Decal-2.0 Cu. In.	1
77	219058	Label-Safety	1
78	Fig. 5	Powerhead Asy	1

① Refer to Chain, Bar and Accessories Catalog - 180119-RI.

② Used on units equipped with Auto Sharp.

③ Used on models with Throttle Latch on Carburetor.

④ Used on models with throttle latch on handle.

⑤ Used on units equipped with Sawdust Shield as original equipment.

SERVICE TOOLS **Figure 2**

- 68915-01 Kit-Piston Pin Installation/
Removal Tool
- 93900 Kit-Cylinder/C'Case Pressure Test
- 215432 Tool-Pressure Test
- 214219 Wrench/Screwdriver
- 216063 Key-Socket 5/32"

Figure 3 CARBURETOR ASSEMBLY

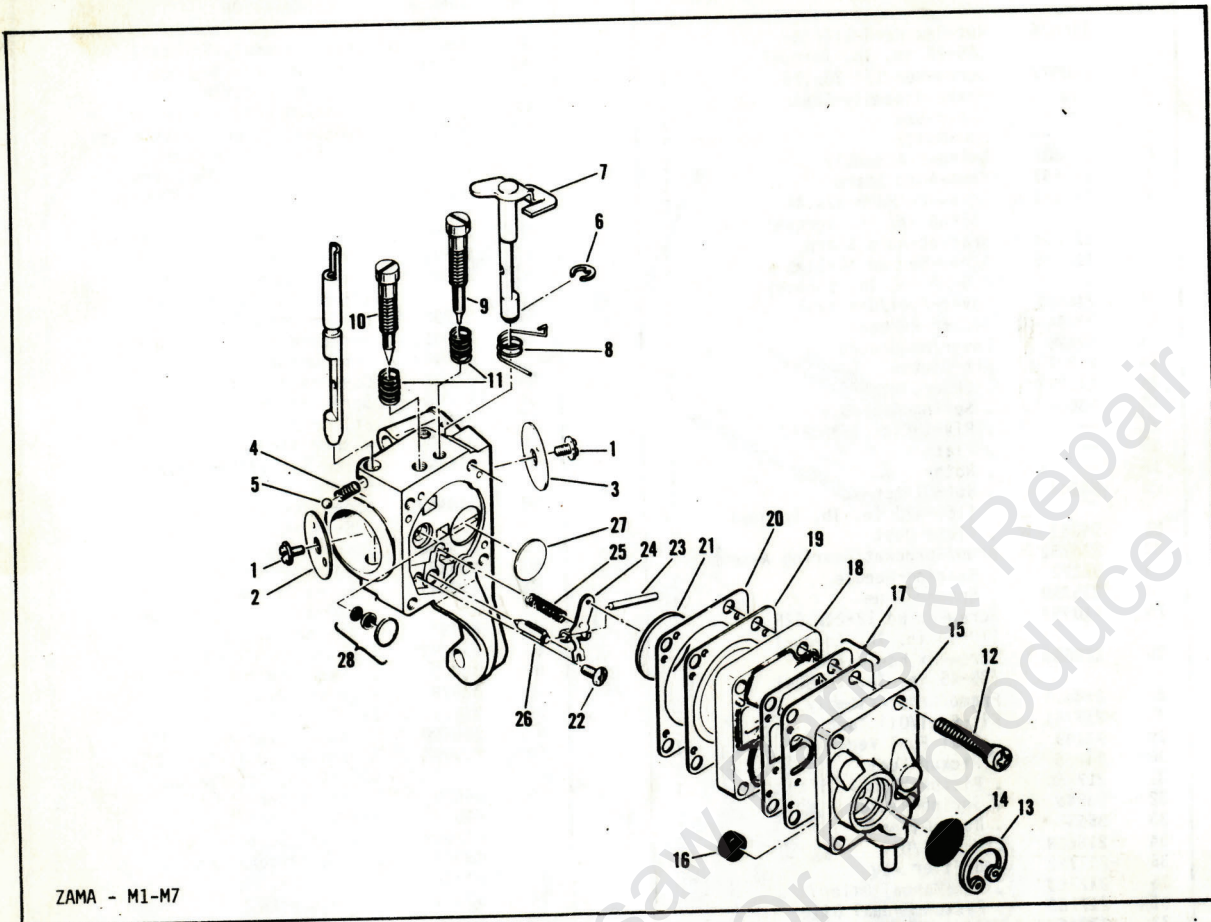

ZAMA - M1-M7

ITEM NO.	PART NUMBER	DESCRIPTION	UNITS PER ASY.
	214082-01	① Carburetor Assy-Zama M1-M7	1
1	--	. Screw - Plate	2
2	--	. Valve - Choke	1
3	--	. Valve - Throttle	1
4	--	. Spring - Choke	1
5	--	. Ball - Friction	1
6	--	. "E" Ring	1
7	--	. Shaft Assembly - Throttle	1
8	--	. Spring - Throttle Return	1
9	--	④ . Screw - Idle Adjustment	1
10	--	④ . Screw - Main Adjustment	2
11	--	④ . Spring - Screw	1
12	--	. Screw - Cover	4
13	--	. "C" Ring	1
14	--	② . Strainer	1

ITEM NO.	PART NUMBER	DESCRIPTION	UNITS PER ASY.
15	--	. Cover - Pump	1
16	--	② . Screen	1
17	--	③② . Kit - Pump diaphragm	1
18	--	. Body - Pump	1
19	--	③② . Diaphragm - Main	1
20	--	③② . Gasket - Main	1
21	--	② . Disk	1
22	--	② . Screw	1
23	--	② . Pin - Arm	1
24	--	② . Arm - Needle Valve	1
25	--	② . Spring - Arm	1
26	--	② . Valve - Needle	1
27	--	② . Plug - Welch	1
28	--	② . Valve Asy - Main Nozzle	1

NOTE
Individual parts are shown for identification and disassembly sequence purposes only and are not available as service replacement parts. The only items available for service are those parts listed in respective repair kits.

① One of two carburetors used alternately. Identify carburetor before ordering repair kits.

② Contained in Repair Kit, P/N 217079.
③ Contained in Gasket/Diaphragm Kit, P/N 216722.
④ Contained in Needle Kit, P/N 217086.

CARBURETOR ASSEMBLY Figure 4

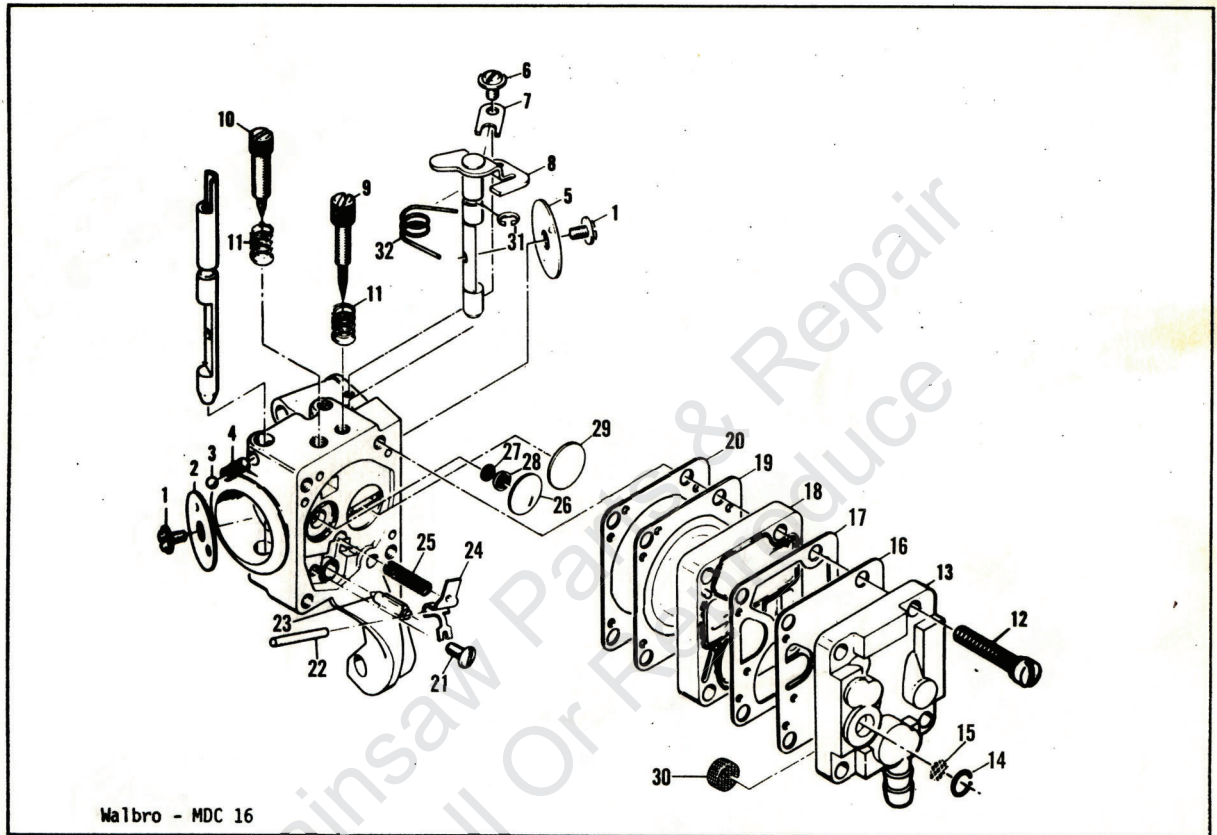

Walbro - MDC 16

ITEM NO.	PART NUMBER	DESCRIPTION	UNITS PER ASY.
	214082-02 ^①	CARBURETOR ASSY - WALBRO MDC 16	
1	-- -- ^②	SCREW - PLATE	2
2	-- --	PLATE - CHOKE	1
3	-- -- ^②	BALL - CHOKE FRICTION	1
4	-- -- ^②	SPRING - CHOKE FRICTION	1
5	-- --	PLATE - THROTTLE	1
6	-- --	SCREW - CLIP	1
7	-- --	CLIP - THROTTLE SHAFT	1
8	-- --	SHAFT ASSEMBLY - THROTTLE	1
9	-- -- ^②	NEEDLE - IDLE	1
10	-- -- ^②	NEEDLE - HIGH SPEED	1
11	-- -- ^②	SPRING - NEEDLE	2
12	-- -- ^②	SCREW ASSEMBLY - BODY	4
13	-- --	COVER ASSEMBLY - PUMP	1
14	-- -- ^{②③}	RING - VENT SCREEN	1
15	-- -- ^{②③}	VENT - SCREEN	1
16	-- -- ^{②③}	DIAPHRAGM - FUEL PUMP	1

ITEM NO.	PART NUMBER	DESCRIPTION	UNITS PER ASY.
17	-- -- ^{②③}	GASKET - METERING DIAPHRAGM	1
18	-- --	BODY - FUEL PUMP	1
19	-- -- ^{②③}	DIAPHRAGM ASSEMBLY - METERING	1
20	-- -- ^{②③}	GASKET - FUEL PUMP	1
21	-- -- ^{②③}	SCREW - METERING LEVER PIN	1
22	-- -- ^{②③}	PIN - METERING LEVER	1
23	-- -- ^{②③}	VALVE - INLET NEEDLE	1
24	-- -- ^{②③}	LEVER - METERING	1
25	-- -- ^{②③}	SPRING - METERING LEVER	1
26	-- -- ^{②③}	PLUG - WELCH 7/16	1
27	-- -- ^{②③}	SCREEN - INLET	1
28	-- -- ^②	RING - INLET SCREEN	1
29	-- -- ^{②③}	PLUG - WELCH 1/2	1
30	-- -- ^{②③}	SCREEN	1
31	-- -- ^{②③}	RING - RETAINING	1
32	-- --	SPRING - THROTTLE RETURN	1

NOTE
Individual parts are shown for identification and disassembly sequence purposes only and are not available as service replacement parts. The only items available for service are those listed in respective repair kits.

① One of two Carburetors were used alternately. When Ordering Repair Kits identify Carburetor. Because Walbro Carburetor, P/N 214082-02, is no longer available, it is necessary to order Zama Carburetor, P/N 214082-01 as service replacement.

② Contained in Major Repair Kit, P/N 217084.

③ Contained in Minor Repair Kit, P/N 216727.

Figure 4 POWERHEAD ASSEMBLY

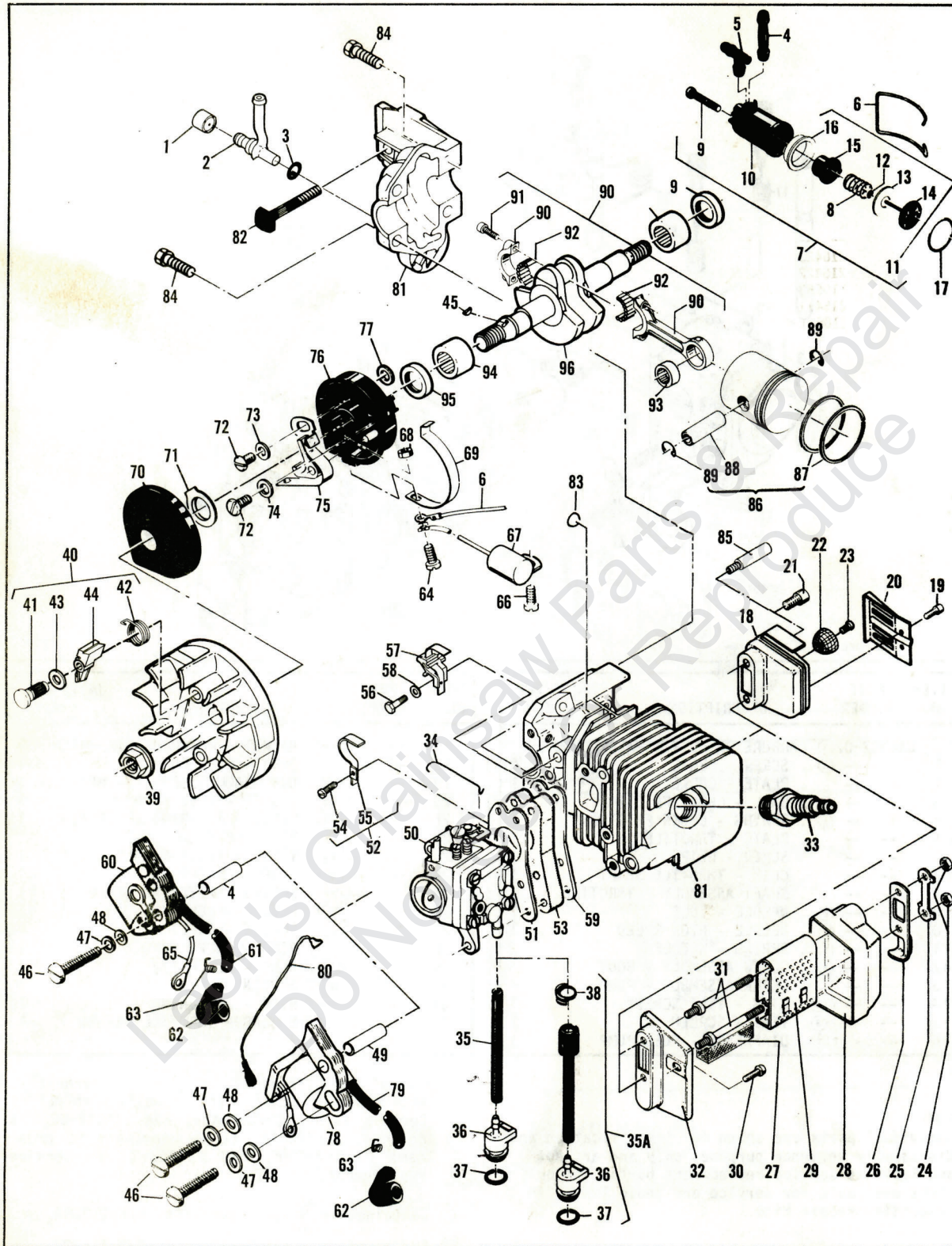

FIGURE 5 POWERHEAD ASSEMBLY

ITEM NO.	PART NUMBER	DESCRIPTION	UNITS PER ASY.
1	86438	① Valve-Check	1
2	217156	① Connector-Oil Tank/Bar Pad	1
3	105603	① Ring- "O" Spacer	1
4	217168	② Connector-Pump/Bar Pad	1
5	217167	② Connector-Pump/Oil Tank	1
6	83896	② Bail-Pump Retaining	1
7	-219989	② Pump Assembly-Oil	1
8	83891	② . Spring-Return	1
9	110651	② . Screw-Oil Flow Adjustment	1
10	-- --	② . Body-Pump	1
11	216426	② . Kit-Oil Pump Repair	1
12	105603	② .. Ring- "O" .114x.070	1
13	-- --	② .. Ring-Oil Pump Piston	1
14	-- --	② .. Piston Assembly-Oiler	1
15	-216423	② .. Sleeve-Oil Pump	1
16	-216422	② .. Eyelet	1
17	110653	② Ring- "O"	1
18	215411	③ Muffler Assembly	1
19	110681	③ . Screw-Skt. Hd. 10-24x.250 (40-45 in. lb. torque)	2
20	92961	③ . Deflector-Exhaust	1
21	215394	③ . Screw-Special (70-80 in. lb. torque)	2
22	214204	③ Kit-Spark Arrestor Screen	1
23	101987	③ . Screw-6-32x.250	1
24	215871	③ Nut-Muffler (40-60 in. lb. torque)	2
25	215471	③ Plate-Lock	1
26	215472	③ Deflector-Exhaust	1
27	216805	③ Screen-Spark Arrestor	1
28	215774	③ Cover	1
29	215776	③ Baffle	1
30	213369	③ Screw-Hex Wsh M6 (70-85 in. lb. torque)	1
31	215757	③ Bolt-Shoulder (65-85 in. lb. torque)	2
32	215773	③ Base	1
33	62345	Plug-Spark DJ8J Champion	1
	92879	Plug-Spark RDJ8 Champion	1
34	-89274	Rod-Throttle	1
35	89059	Hose-Fuel	1
36	90660	Adaptor-Fuel Hose	1
37	110908	Ring- "O" Adaptor	1
35A	-90661	④ Kit-Fuel Hose	1
36	90660	④ . Adaptor-Fuel Hose	1
37	110908	④ . Ring- "O"	1
38	-87826	④ . Clamp-Fuel Hose	1
39	216640	④ Nut-Hex 5/16-24 (200-220 in. lb. torque)	1
40	94737	Flywheel/Pawl Assembly	1
41	216984	⑤ . Pin-Pawl	2
42	216982	⑤ . Spring-Pawl	2
43	93469	⑤ . Washer-Pawl	2
44	216983	⑤ . Pawl-Starter	2
45	102164	Key-Woodruff	1
46	-222866	Screw-Pan Head 8-32x1.75	3
47	105976	Washer-Flat 11/64"	3
48	67177	Washer-Insulating	3
49	68198	Tube-Insulating	3
50	Fig. 3,4	Carburetor Assemblies	1
51	68197	Gasket-Carburetor	1
52	219389	⑥ Connector/Insulator Assy	1
53	219754	. Insulator-Carburetor	1
54	-- --	⑥ . Screw-Connector	1
55	219390	. Connector-Stop Switch	1

ITEM NO.	PART NUMBER	DESCRIPTION	UNITS PER ASY.
56	-- --	⑥ Screw-Hex HD 8-32x1/2	1
57	-- --	⑥ Connector-Stop Switch	1
58	-- --	⑥ Eyelet-Connector	1
59	90714	Gasket-Insulator	1
60	84957	⑦ Coil-Lamination Assembly	1
61	215351	⑦ . Wire Assembly-Spark Plug	1
62	-95266	⑦ . Boot	1
63	-102556	⑦ . Connector	1
64	110364	⑦ Screw-Pan Head 6-32x.625	1
65	69344	⑦ Wire Assembly-Coil	1
66	110041	⑦ Screw-Pan Head 8-32x.50	1
67	85358	⑦ Condenser	1
68	190035	⑦ Nut-Hex 6-32	1
69	84502	⑦ Connector-Stop Switch	1
70	67841	⑦ Cover-Breaker Box	1
71	69323	⑦ Seal-Breaker Box	1
72	213032	⑦ Screw-Hex Head 8-32x.50	2
73	69322	⑦ Washer-Special	1
74	105975	⑦ Washer-Flat 11/64"	1
75	88821	⑦ Breaker-Assembly	1
76	⑦ 84505-01	Kit-Breaker Box	1
77	92037	⑦ . Washer	1
78	217031	⑧ Ignition Assembly-CDI	1
62	-95266	⑧ . Boot	1
63	-102556	⑧ . Connector	1
79	-- --	⑧ . Wire-Spark Plug	1
80	217190	⑧ Wire Assembly-Stop Switch	1
81	217165	⑧ Cylinder/Crankcase Using Auto Sharp	1
82	83856	. Bolt-Bar Mounting	1
83	110914	. Plug-Cup	4
81	216935	② Cylinder/Crankcase Using Automatic Oiler	1
82	83856	. Bolt-Bar Mounting	1
83	110914	. Plug-Cup	4
81	217067	① Cylinder/Crankcase Without Automatic Oiler	1
82	83856	. Bolt-Bar Mounting	1
83	110914	. Plug-Cup	4
84	120097	. Screw-Hex M5x25 (70-80 in. lb. torque)	4
81	216950	⑩ Cylinder/Crankcase (Plated) Using Automatic Oiler	1
82	83856	. Bolt-Bar Mounting	1
83	110914	. Plug-Cup	4
84	120097	. Screw-Hex M5x25 (70-80 in. lb. torque)	4
85	213327	⑫ . Screw-Special	2
86	94662	Piston Assembly	1
87	95143	. Ring-Piston	2
88	92836	. Pin-Piston	1
89	111026	. Ring-Snap	2
86	216713	⑬ Piston Assembly (Non-Plated)	1
87	216705	. Ring-Piston	1
88	92836	. Pin-Piston	1
89	111026	. Ring-Snap	2
90	94135	Rod Assembly-Connecting	1
91	94654	. Screw-Connecting Rod	2
92	68095	. Roller-Needle (set of 20)	1
93	110984	. Bearing-Needle	1
94	213282	⑭ Bearing-Crankshaft	2
95	83859	⑭ Seal-Crankshaft	2
96	-217042	⑭ Crankshaft	1
	-91932	⑭ Crankshaft	1

- ① Used on units with manual oiler only.
- ② Used on units equipped with automatic oiler.
- ③ One of two Muffler Assemblies used. Identify which one you have prior to ordering replacement parts.
- ④ Used with Walbro Carburetors only.
- ⑤ See Service Bulletin 1833. When replacing metal pawls with plastic pawls, order these components.
- ⑥ One of two Stop Switch Connectors installed by the factory.
NOTE: Item 52, P/N 219389 is used as replacement for item numbers 54, 56, 57, and 58.
- ⑦ Used on units equipped with Points and Coil.

- ⑧ Used on units equipped with CDI Ignition.
- ⑨ Used on units equipped with Auto Sharp.
- ⑩ Used on Mac 160S and Eager Beaver Super 16 only.
- ⑪ If the Crankshaft Bearing and Seal have been installed into a Metal Sleeve, order part number 93763 which includes the Sleeve and item numbers 94 and 95.
- ⑫ Used as original equipment only.
- ⑬ Coil-Lamination Assembly, P/N 84957 can only be used with Crankshaft, P/N 91932.
- ⑭ Electronic Ignition, P/N 217031 can only be used with Crankshaft, P/N 217042.

Figure 6 BRAKE HOUSING ASSEMBLIES

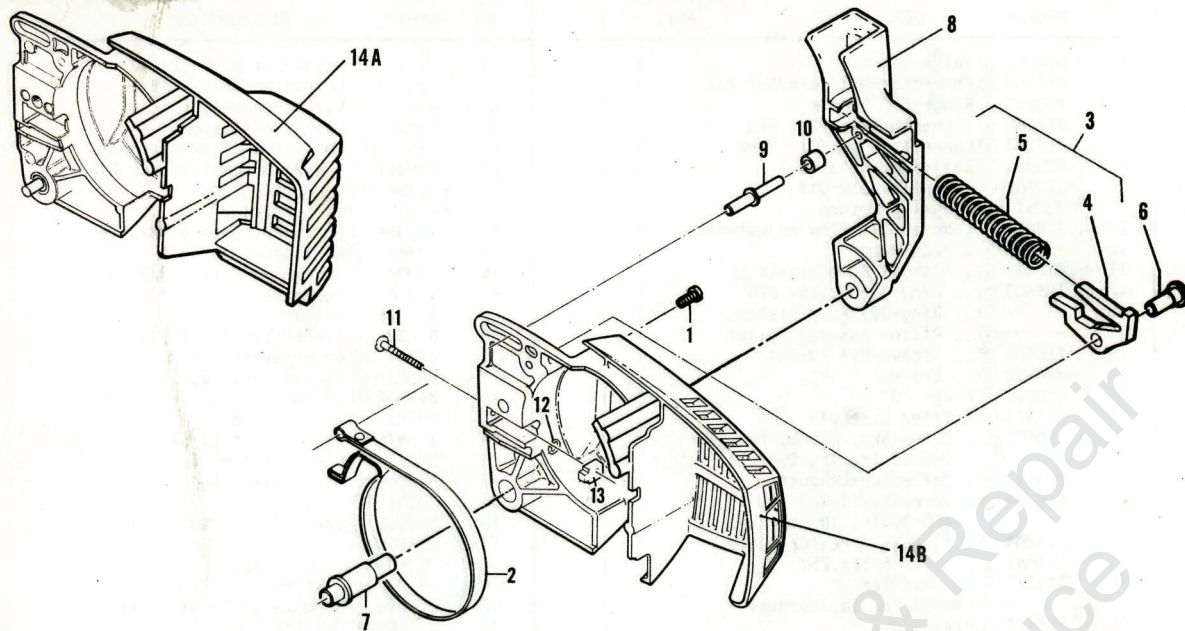

ITEM NO.	PART NUMBER	DESCRIPTION	UNITS PER ASY.	ITEM NO.	PART NUMBER	DESCRIPTION	UNITS PER ASY.
A	216551 ①	Brake Assembly-Chain	1	8	92867	Lever	1
B	216416 ①	Brake Assembly-Chain	1	9	213907	Pin-Roller	1
1	111047	Screw-Pan Hd 8-32x.625	1	10	214368	Bearing-Roller	1
2	94709	Band-Brake	1	11	90658	Screw-Adjusting	1
3	215758	Kit-Latch	1	12	110907	Ring-Retaining	1
4	216755	Latch	1	13	84929	Nut-Bar Adjusting	1
5	215721	Spring-Compression	1	14A	216553 ①	Housing-Brake	1
6	93602	Pivot-Latch	1	14B	216414 ①	Housing-Brake	1
7	216549	Pivot-Lever	1				

① One of two Brake Housings used. Identify which Brake you have prior to ordering replacement parts.

SERVICE NOTE:

This Brake Housing Assembly is now made with the Sawdust Deflector molded into the Housing. If your Chain Saw was originally equipped with the Sawdust Deflector attached to the Powerhead, it must be removed and discarded prior to installation of your replacement Brake Housing.

Figure 7 SPECIFICATIONS

Displacement	2.0 cu. in.
Bore & Stroke	1.430 x 1.201 in. (36.5 x 30.5mm)
Bearings-Main & Con Rod	Needle
Intake System	3rd Port, Piston Timed
Fuel Capacity	10.8 oz. (320cc)
Oil Capacity	3.2 oz. (95cc)
Clutch Engaging Speed	3800 to 4200 r.p.m.
Idle Speed	2700 to 2900 r.p.m.
Ignition	Solid State Electronic
Carburetor	Diaphragm Type, 2 Needle
Fuel Type	Regular Grade Leaded or Unleaded
Fuel/Oil Mixture	40:1 Using McCulloch Oil
Filter System-Fuel	Felt
Filter System-Air	Flocked Screen
Lamination Gap	.008" to .012" (.203 to .304mm)
Piston Rings (2)	Cast Iron Compression
Weight (Power Unit Only)	10.1 lbs (4.6 kg)



● MANUFACTURING ● SALES ● SERVICE ●

McCULLOCH
CORPORATION

900 Lake Havasu Ave.
Lake Havasu City, AZ 86403-2891

**FOR SERVICE-RELATED PROBLEMS,
REPAIR OR MAINTENANCE
TAKE YOUR UNIT TO THE NEAREST
AUTHORIZED McCULLOCH SERVICING
DEALER LISTED UNDER SAWS IN YOUR
TELEPHONE DIRECTORY YELLOW PAGES.**

If additional assistance is required, call this toll-free hot-line:
(800) 423-6302

Arizona residents call collect (602) 453-3681