

MASTER ILLUSTRATED PARTS LIST

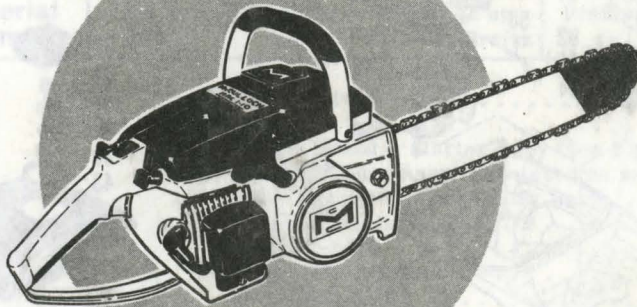

MAC 1-10 Chain Saw

January 1970

CONTENTS

The policy of McCulloch Corporation is one of continual improvement in design, manufacturing and engineering advancement wherever possible to assure still finer two-cycle power tools. Hence, specifications, equipment, colors, design and manufacturer's suggested list prices are subject to change without notice and McCulloch Corporation reserves the right to make such changes without prior notification or obligation to backfit or supply backfit components for units previously shipped from the factory.

	Page
Figure 1. General	2
Figure 2. Clutch Guard & Starter Assy ..	6
Figure 3. Fuel Tank Assembly	6
Figure 4. Fuel Tank Assembly	8
Figure 5. Carburetor Assembly	10
Figure 6. Carburetor Assembly	12
Figure 7. Carburetor Assembly	14
Figure 8. Powerhead Assembly	16

This Master Illustrated Parts List gives the name, number and interchangeability between engines, of service and replacement parts which were used on or are presently available for all MAC 1-10 chain saws manufactured to date.

Information about the List and how to use it will be found on the back cover. Read the information before you start to use the List.

 **McCULLOCH**

Copyright 1970 U.S.A. -
McCulloch Corporation

P/N 84289

MAC 1-10

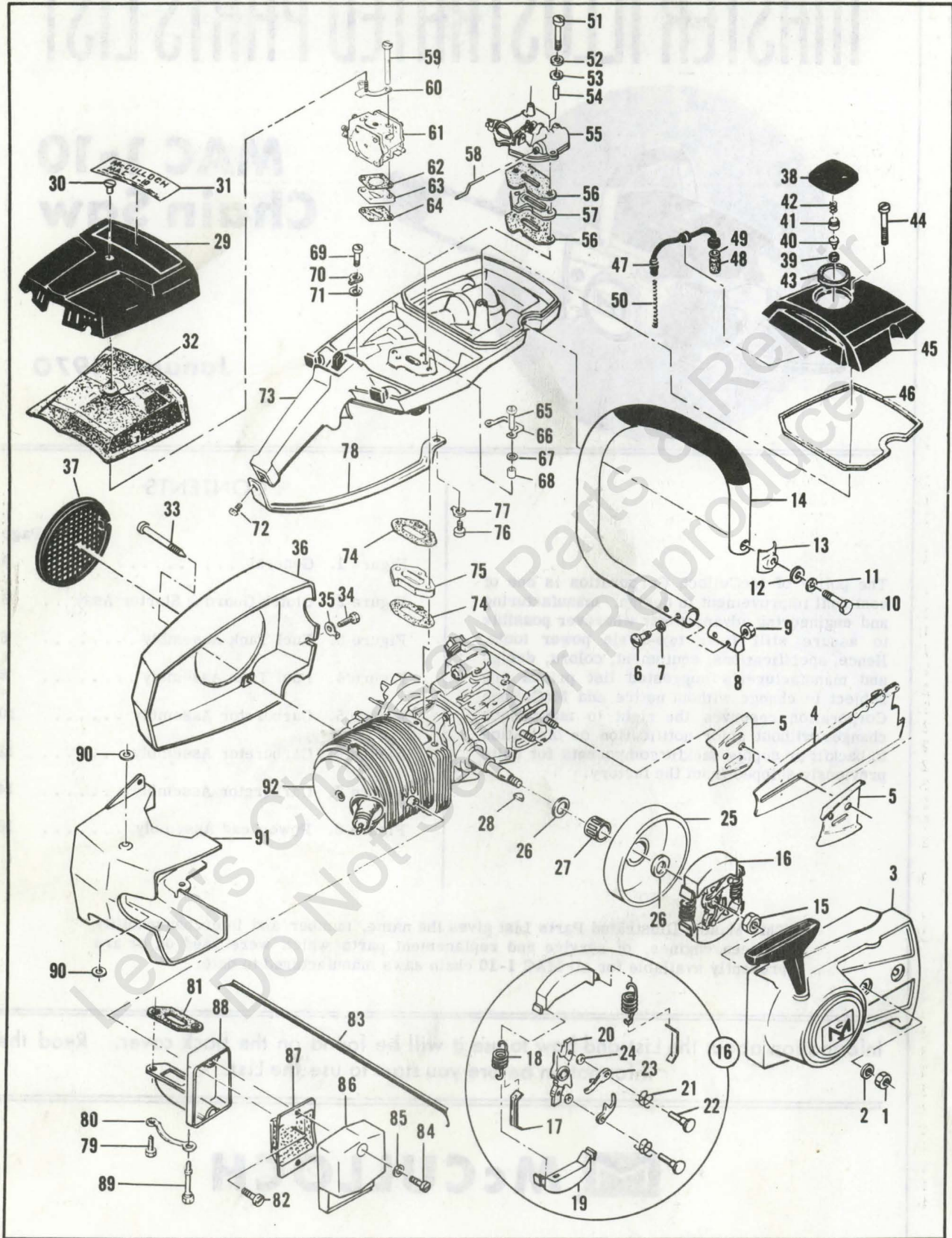

Figure 1. General

FIGURE 1. GENERAL

Item No.	Part Number	Description	Units Per Assy	Usable on Code			
MAC 1-10 SAW - USABLE ON CODE							
Letter	A	B	C	D	E	F	G
Serial Numbers	Up to 27001	27001 to 75001	75001 and up Without Prefix	Prefixed 1-	Prefixed 2-	Prefixed 10-	Prefixed 11-
1	110454	Nut - Hex 5/16-24		2	All		
2	100440	Washer - 5/16		2	All		
3		Clutch Guard & Starter Assy (See Figure 2)			All		
4		Bar and Chain Assy (Furnished on saws coded 'G').			All		
5	64330	Set - Bar plates (Accessory Item)		1	All		
6	102761	Screw - Hex hd 10-24 x 7/8		2	All		
7	100352	Washer - #10		2	All		
8	61678	Plug - Nut retainer		1	All		
9	101326	Nut - Hex 10-24		2	All		
10	101977	Screw - Fil hd 1/4-20 x 3/4		1	A,B,C		
	105187	Screw - Skt hd 1/4-20 x 1-1/8		1	D,E		
	* 102130	Screw - Hex hd 1/4-20 x 1-1/2		1	F,G		
11	105043	Lockwasher - 1/4		1	A,B,C		
	* 100153	Lockwasher - 1/4		1	F,G		
12	100004	Washer - 1/4		1	A,B,C,D,E		
13	* 63484	Clamp		1	F,G		
14	67372	Kit - Frame & Grip		1	A,B,C,D,E		
	69054	Frame & Grip Assy		1	F,G		
15	110350	Nut - Flexloc 5/16-24		1	A,B		
	103746	Nut - Flexloc 3/8-24		1	C,D,E,F,G		
16	67148	Clutch Assy		1	All		
17	64583	. Retainer		2	All		
18	66384	. Spring - Clutch		2	All		
19	67233	. Shoe - Clutch		2	All		
20	67149	. Rotor Assy		1	All		
21	68837	. Spring - Pawl		2	All		
22	67112	. Rivet		2	All		
23	64857	. Pawl		2	All		
24	65473	. Washer - Special		2	All		
25	65370	Kit - Sprocket and Drum Assy		1	All		
26	61692	. Shim		2	All		
27	110330	Bearing - Sprocket		1	All		
28	103879	Key - Woodruff		1	All		
29	62117	Cover Assy - Air cleaner		1	A,B,C		
	65866	Cover Assy - Air cleaner		1	D,E,F,G		
30	62434	. Nut - Cover		1	A,B,C		
	65813	. Nut - Cover		1	D,E,F,G		
31	66451	Nameplate		1	All		
32	62077	Screen - Air cleaner		1	A,B,C		
	66774	Screen - Air cleaner		1	D,E,F		
	68520	Screen - Air cleaner		1	G		
33	62978	Screw - Special		3	All		
34	105348	Screw - Hex hd 10-24 x 1/2		1	G		
35	69890	Lockplate		1	G		
36	83521	Kit - Fan housing		1	All		
37	55615	. Guard - Flywheel		1	All		
38	68531	Fuel Cap Assy		1	All		
39	68533	. Plug		1	All		
40	63041	. Valve		1	All		
41	62316	. Guide		1	All		
42	63040	. Spring		1	All		
43	65671	. Gasket		1	All		
44	110334	Screw - Oval hd 12-24 x 1-3/4		1	All		

* Included with Frame & Grip Kit, P/N 67372

FIGURE 1. GENERAL (CONTINUED)

Item No.	Part Number	Description	Units Per Assy	Usable on Code
45	64796	Cover - Fuel tank	1	A,B
	63656	Cover - Fuel tank	1	C,D,E,F,G
46	62102	Gasket - Cover	1	All
47	63935	Hose Assy - Fuel	1	A,B
	64848	Hose Assy - Fuel	1	C,D,E,F,G
48	63932	Filter - Fuel	1	All
49	100440	Washer 5/16	1	All
50	67944	Spring - Hose	1	All
51	102433	Screw - Hex hd 10-24 x 1-5/8	2	A,B
	103355	Screw - Hex hd 10-24 x 1-7/8	2	C
	103124	Screw - Hex hd 10-24 x 2	2	D,E,F
52	100352	Washer - #10	2	A,B
	64856	Washer - #10	2	C,D,E,F
53	68203	Washer - Insulator	2	All
54	62327A	Sleeve - Insulator	2	A,B,C
	65726	Sleeve - Insulator	2	D,E,F
55		Carburetor Assy (See Figure 5)		A,B,C
		Carburetor Assy (See Figure 6)		D,E,F
56	65672	Gasket - Carburetor	1	A,B,C
	65672	Gasket - Carburetor	2	D,E,F
57	65821	Insulator - Carburetor	1	D,E,F
58	62066A	Rod - Primer	1	A,B,C
	65604	Rod - Primer	1	D,E,F
59	110551	Screw - Hex hd 10-24 x 2-1/8	2	G
60	66681	Bracket Assy	1	G
61		Carburetor Assy (See Figure 7)		G
62	68132	Gasket - Carburetor	1	G
63	66678	Spacer - Carburetor	1	G
64	68131	Gasket - Spacer	1	G
65	110553	Screw - Hex hd 10-24 x 1-3/8	2	G
66	68582	Lockplate	1	G
67	100003	Washer - #10	2	G
68	66189	Sleeve	2	G
69	102760	Screw - Hex hd 10-24 x 1	1	A,B
	102290	Screw - Hex hd 10-24 x 1-1/8	1	C,D,E,F
	110516	Screw - Hex hd 10-24 x 1-1/8	1	G
70	63475	Lockplate	1	E,F,G
	100352	Washer - #10	1	A,B
	64856	Washer - #10	1	C,D
71	68203	Washer - Insulator	1	A,B,C,D,E,F
	64856	Washer - #10	1	G
72	110353	Screw - Oval hd 10-24 x 3/8	1	All
73		Fuel Tank Assy (See Figure 3)		A,B,C,D,E,F
		Fuel Tank Assy (See Figure 4)		G
74	68130	Gasket - Fuel tank	2	All
75	61680B	Insulator - Fuel tank	1	A
	63396	Insulator - Fuel tank	1	B,C,D,E,F
	66659	Insulator - Fuel tank	1	G
76	102289	Screw - Hex hd 10-24 x 3/4	1	All
77	100352	Washer - #10	1	A,B,C,D,E
	69890	Lockplate	1	F,G
78	69838	Brace - Handle		All
79	110506	Screw - Hex hd 10-24 x 5/8	1	All
80	67922	Lockplate	1	All
81	68149	Gasket - Spark arrester	1	All
82	110341	Screw - Hex hd 10-24 x 1/2	1	All
83	68194	Spark Arrester Assy	1	All
84	102290	Screw - Hex hd 10-24 x 1-1/8	2	All
85	110264	Washer - #10	2	All
86	62380	Cover Assy	1	All
87	62379B	Baffle	1	All

FIGURE 1. GENERAL (CONTINUED)

Item No.	Part Number	Description	Units Per Assy	Usable on Code
88	83105	. Body and Duct Assy	1	All
89	68187	. . Screw - Special	1	All
90	62085A	Insulator - Shroud	2	All
91	67377	Shroud	1	All
92		Powerhead Assy (See Figure 8)		All

SERVICE SPECIFICATIONS

Spark Plug Gap	-----	0.025 in.
Lamination Gap	-----	0.010 to 0.015 in.
Breaker Point Gap	-----	0.018 in.
Torque Values		
Flywheel Nut	-----	240 to 300 inch-pounds.
Clutch Nut	-----	160 to 170 inch-pounds.
Connecting Rod Screws	-----	65 to 70 inch-pounds.

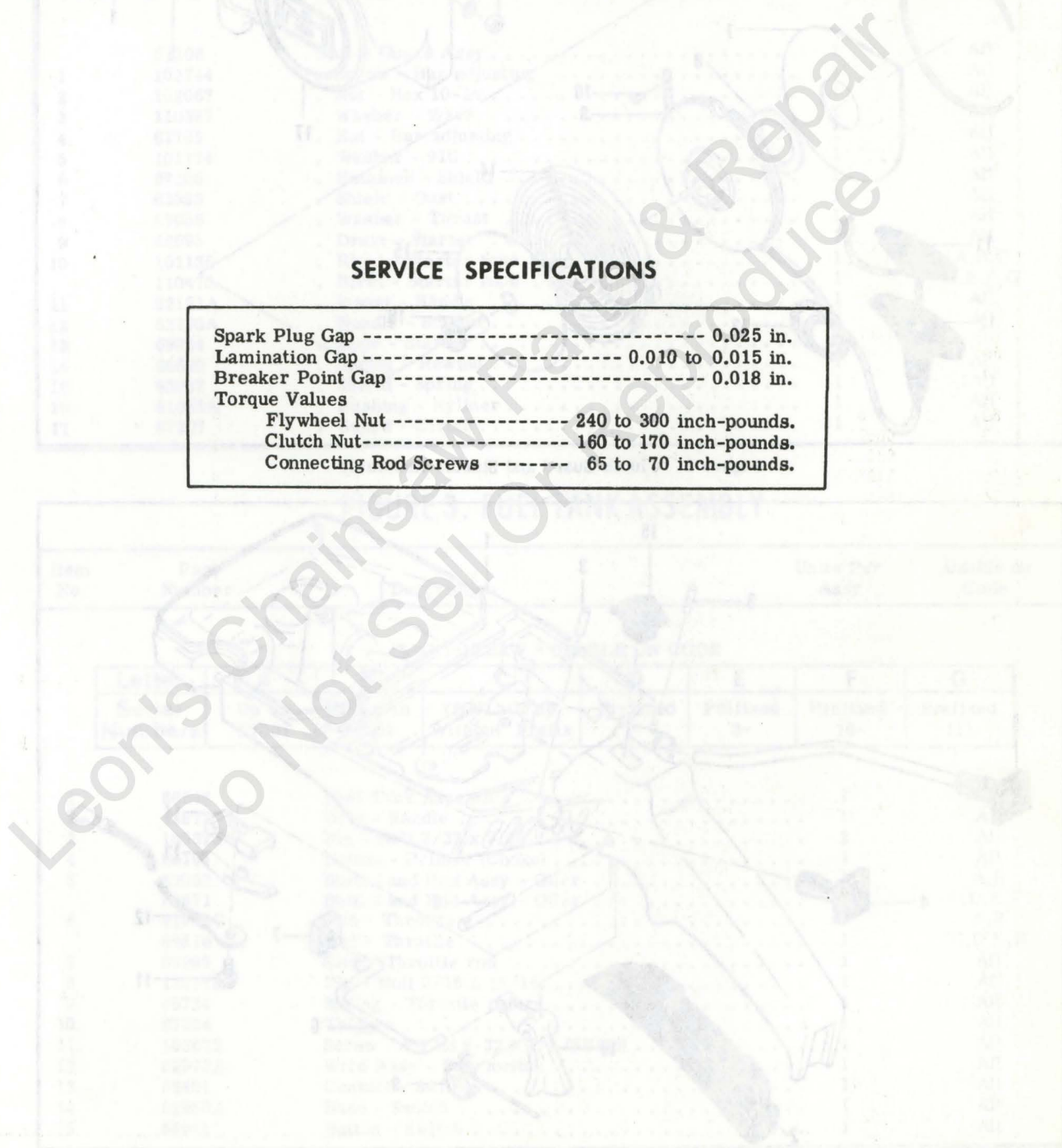

MAC 1-10

FIGURE 2 GENERAL (CONTINUED)

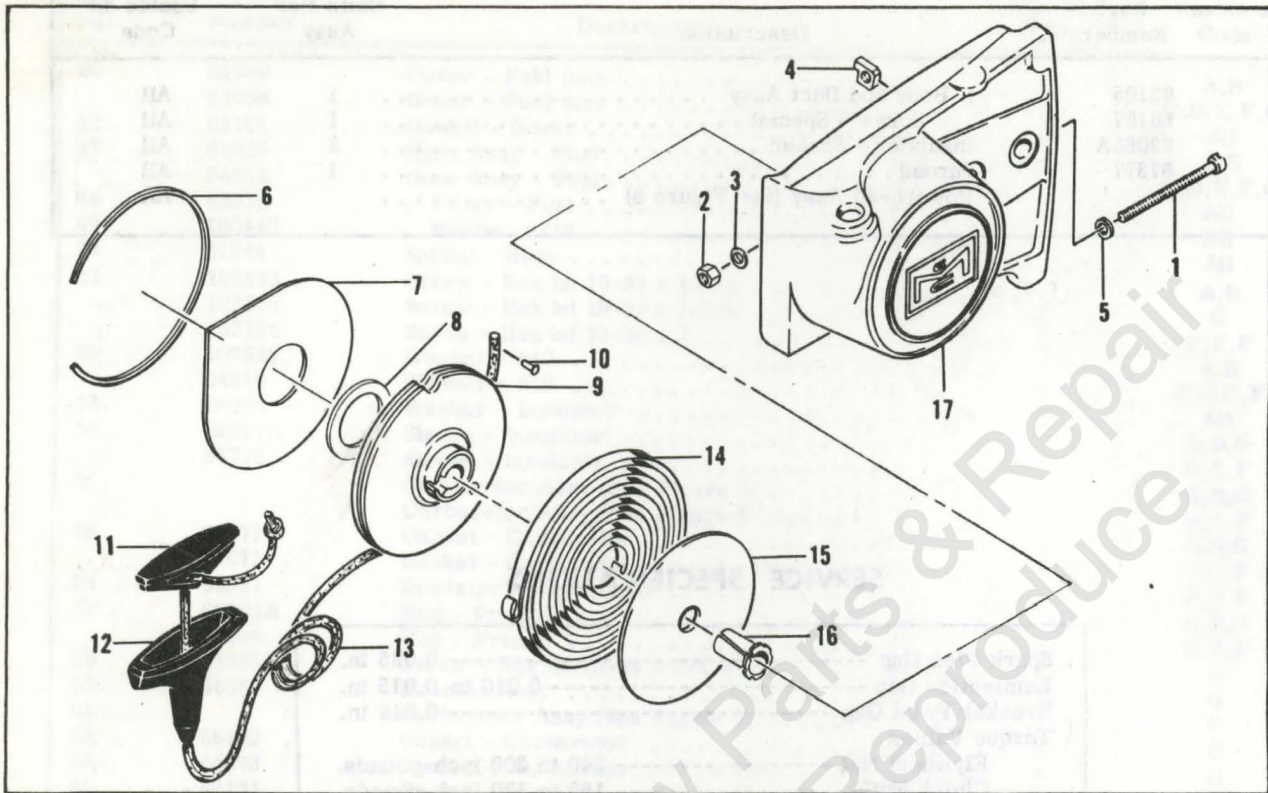

Figure 2. Clutch Guard and Starter Assembly

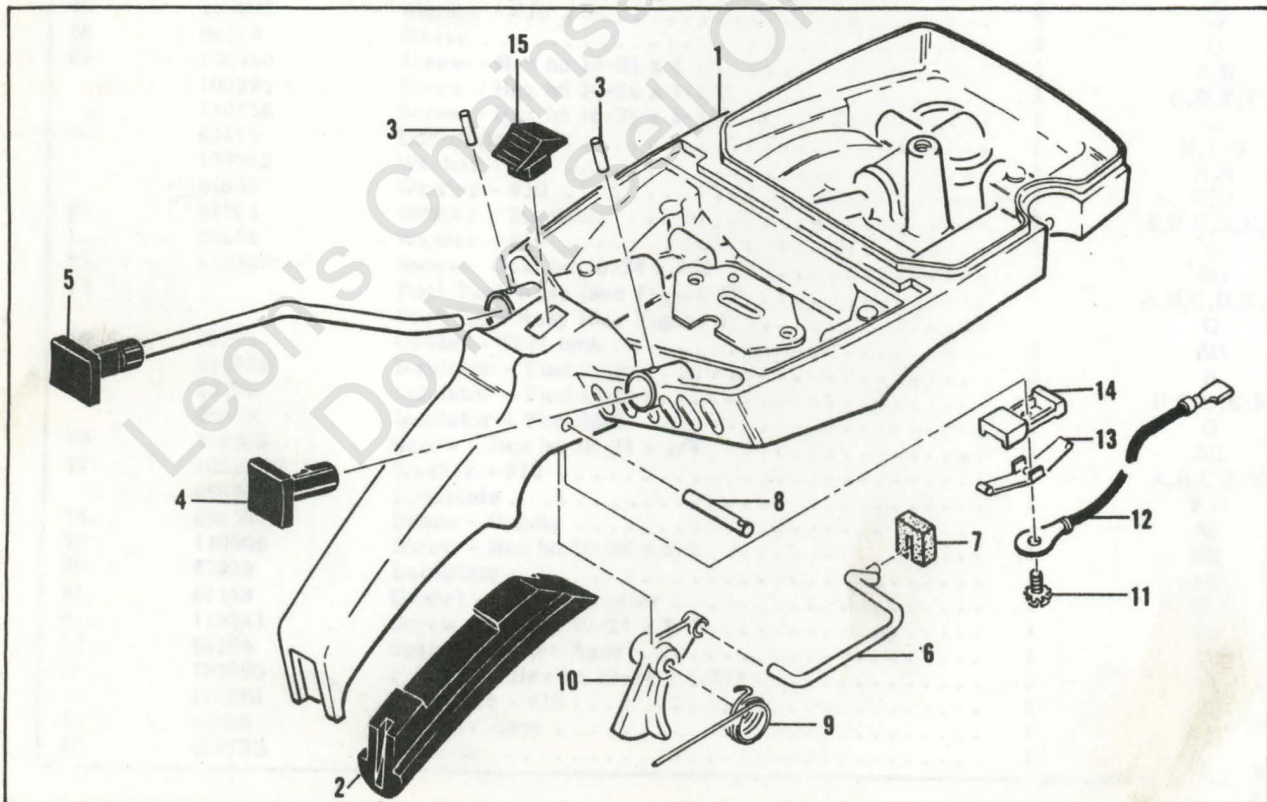

Figure 3. Fuel Tank Assembly

FIGURE 2. CLUTCH GUARD ASSEMBLY

Item No.	Part Number	Description	Units Per Assy	Usable on Code				
MAC 1-10 SAW - USABLE ON CODE								
	Letter	A	B	C	D	E	F	G
	Serial Numbers	Up to 27001	27001 to 75001	75001 and up Without Prefix	Prefixed 1-	Prefixed 2-	Prefixed 10-	Prefixed 11-
1	67206	Clutch Guard Assy	1	All				
2	102144	. Screw - Bar adjusting	1	All				
3	102067	. Nut - Hex 10-24	1	All				
4	110387	. Washer - Wave	1	All				
5	61705	. Nut - Bar adjusting	1	All				
6	101174	. Washer - #10	1	All				
7	67205	. Retainer - Shield	1	All				
8	63985	. Shield - Dust	1	All				
9	63986	. Washer - Thrust	1	All				
10	68695	. Drum - Starter	1	All				
11	101136	. Rivet - Starter rope	1	A,B,C				
12	110470	. Rivet - Starter rope	1	D,E,F,G				
13	62191A	. Insert - Handle	1	All				
14	62190A	. Handle - Starter	1	All				
15	69964	. Rope - Starter	1	All				
16	68626	. Spring - Rewind	1	All				
17	63987	. Shield - Spring	1	All				
	61635A	. Bushing - Nyliner	1	All				
	67207	. Guard - Clutch	1	All				

FIGURE 3. FUEL TANK ASSEMBLY

Item No.	Part Number	Description	Units Per Assy	Usable on Code				
MAC 1-10 SAW - USABLE ON CODE								
	Letter	A	B	C	D	E	F	G
	Serial Numbers	Up to 27001	27001 to 75001	75001 and up Without Prefix	Prefixed 1-	Prefixed 2-	Prefixed 10-	Prefixed 11-
1	66648	Fuel Tank Assembly	1	All				
2	64872	Grip - Handle	1	All				
3	105673	Pin - Roll 3/32 x 9/16	2	All				
4	66194	Button - Primer (Choke)	1	All				
5	63052	Button and Rod Assy - Oiler	1	A,B				
6	64871	Button and Rod Assy - Oiler	1	C,D,E,F				
7	62970C	Rod - Throttle	1	A,B				
8	65816	Rod - Throttle	1	C,D,E,F				
9	67989	Seal - Throttle rod	1	All				
10	110378	Pin - Roll 3/16 x 15/16	1	All				
11	65734	Spring - Throttle return	1	All				
12	67224	Trigger	1	All				
13	103672	Screw - Fil hd 8-32 x 1/2 (SEMS)	1	All				
14	62973A	Wire Assy - Stop switch	1	All				
15	62451	Contact - Switch	1	All				
	62950A	Base - Switch	1	All				
	62951	Button - Switch	1	All				

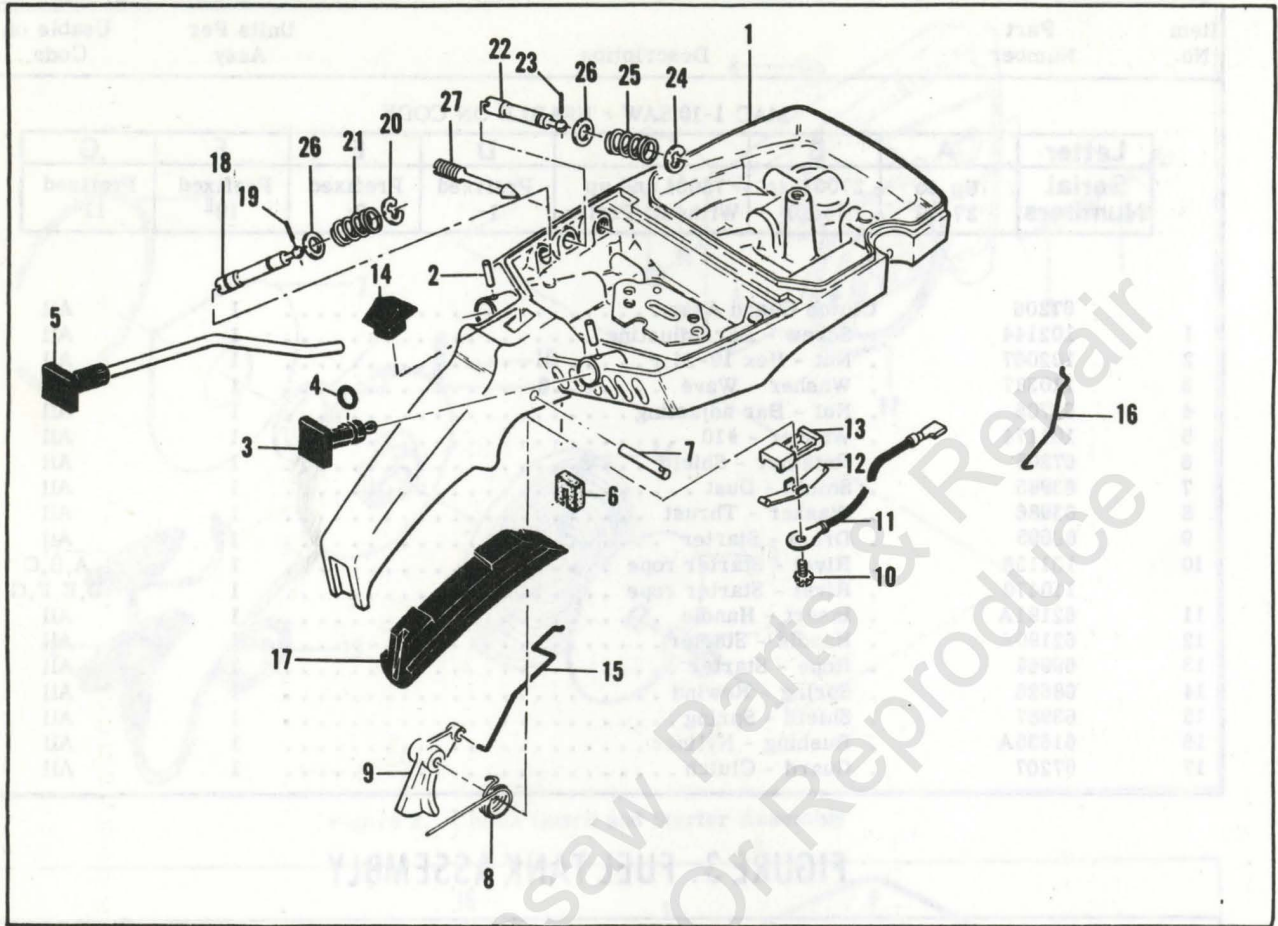

Figure 4. Fuel Tank Assembly

Leon's Chainsaw Parts & Repair
Do Not Sell Or Reproduce

Letter	Serial Numbers	Up to 7501	7501 to 7600	7600 and up	Part Name
A	6871	7501	7600	7600 and up	Fuel Tank Assembly
B	6872	7501	7600	7600 and up	Cap - Handle
C	6873	7501	7600	7600 and up	Pin - Ball 3/16 x 1/2
D	6874	7501	7600	7600 and up	Bracket - Trigger Control
E	6875	7501	7600	7600 and up	Button and Pin Assy - Trigger
F	6876	7501	7600	7600 and up	Button and Pin Assy - Guard
G	6877	7501	7600	7600 and up	Pin - Trigger
H	6878	7501	7600	7600 and up	Pin - Trigger
I	6879	7501	7600	7600 and up	Pin - Trigger
J	6880	7501	7600	7600 and up	Pin - Trigger
K	6881	7501	7600	7600 and up	Pin - Trigger
L	6882	7501	7600	7600 and up	Pin - Trigger
M	6883	7501	7600	7600 and up	Pin - Trigger
N	6884	7501	7600	7600 and up	Pin - Trigger
O	6885	7501	7600	7600 and up	Pin - Trigger
P	6886	7501	7600	7600 and up	Pin - Trigger
Q	6887	7501	7600	7600 and up	Pin - Trigger
R	6888	7501	7600	7600 and up	Pin - Trigger
S	6889	7501	7600	7600 and up	Pin - Trigger
T	6890	7501	7600	7600 and up	Pin - Trigger
U	6891	7501	7600	7600 and up	Pin - Trigger
V	6892	7501	7600	7600 and up	Pin - Trigger
W	6893	7501	7600	7600 and up	Pin - Trigger
X	6894	7501	7600	7600 and up	Pin - Trigger
Y	6895	7501	7600	7600 and up	Pin - Trigger
Z	6896	7501	7600	7600 and up	Pin - Trigger

FIGURE 4. FUEL TANK ASSEMBLY

Item No.	Part Number	Description	Units Per Assy	Usable on Code				
MAC 1-10 SAW - USABLE ON CODE								
	Letter	A	B	C	D	E	F	G
	Serial Numbers	Up to 27001	27001 to 75001	75001 and up Without Prefix	Prefixed 1-	Prefixed 2-	Prefixed 10-	Prefixed 11-
1	68683	Fuel Tank Assy			1			G
2	105673	Pin - Roll 3/32 x 9/16			2			G
3	68517	Button - Choke			1			G
4	101056	"O" Ring			1			G
5	64871	Button & Rod Assy			1			G
6	67989	Seal - Throttle rod			1			G
7	110378	Pin - Roll 3/16 x 15/16			1			G
8	65734	Spring - Throttle return			1			G
9	67224	Trigger			1			G
10	103672	Screw - Fil hd 8-32 x 1/2 (SEMS)			1			G
11	62973A	Wire Assy - Stop switch			1			G
12	62451	Contact - Switch			1			G
13	62950A	Base - Switch			1			G
14	62951	Button - Switch			1			G
15	68170	Rod - Throttle			1			G
16	67355	Rod - Choke			1			G
17	64872	Grip - Handle			1			G
18	68102	Extension Assy - High speed			1			G
19	110509	. Pin - Groove			1			G
20	110512	. Ring - Retaining			1			G
21	67363	. Spring			1			G
22	68101	Extension Assy - Idle			1			G
23	110509	. Pin - Groove			1			G
24	110512	. Ring - Retaining			1			G
25	67363	. Spring			1			G
26	67292	Washer			2			F
27	67271	Screw - Idle adjustment			1			F

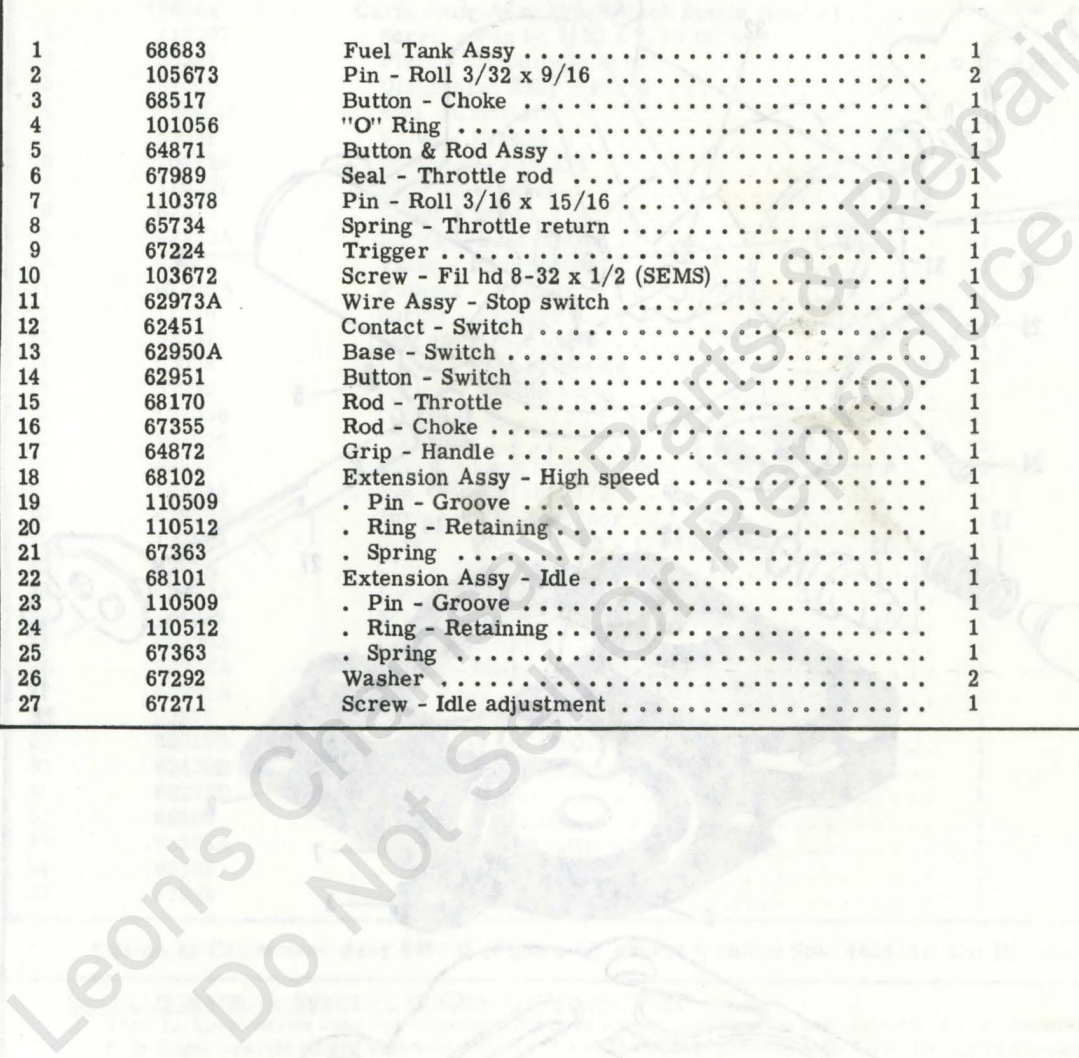

FIGURE 5. CARBURETOR ASSEMBLY

Item No.	Part Number	Description	Units Per Assy	Usable on Code				
MAC 1-10 SAW - USABLE ON CODE								
	Letter	A	B	C	D	E	F	G
	Serial Numbers	Up to 27001	27001 to 75001	75001 and up Without Prefix	Prefixed 1-	Prefixed 2-	Prefixed 10-	Prefixed 11-
1	*66564		Carburetor Assy (McCulloch Single Needle)				1	A,B,C
2	110397		. Screw - Pan hd 8-32 x 7/16 (SEMS)				5	A,B,C
3	65597		. Plate - Carburetor base				1	A,B,C
4	67357		. Diaphragm Assy - Pump				1	A,B,C
5	55690B		. Seal - Capillary				1	A,B,C
6	63041		. Valve - Primer				1	A,B,C
7	104728		. Screw - 6-32 x 1/4				1	A,B,C
8	110337		. Pin - Inlet lever				1	A,B,C
9	62310		. Lever - Inlet				1	A,B,C
10	62923A		. Spring - Inlet needle				1	A,B,C
11	63038		. Valve - Inlet needle				1	A,B,C
12	62308A		. Plunger - Primer				1	A,B,C
13	11086		. Spring - Plunger				1	A,B,C
14	63037		. Seat - Primer valve				1	A,B,C
15	63038		. Valve - Primer needle				1	A,B,C
16	63039		. Spring - Needle valve				1	A,B,C
17	101056		. "O" Ring				1	A,B,C
18	105606		. "O" Ring				1	A,B,C
19	62971		. Screw - Long locking adjusting				2	A,B,C
20	104245		. Pin - Roll 1/16 x 1/2				1	A,B,C
21	62939A		. Spring - Idle governor				1	A,B,C
22	103934		. Screw - Pan hd 6-32 x 1/4 (SEMS)				1	A,B,C
23	62938		. Clip - Throttle shaft				1	A,B,C
24	62343A		. Lever - Throttle				1	A,B,C
25	104814		. Screw - Pan hd 4-40 x 1/4 (SEMS)				1	A,B,C
26	62290A		. Plate - Throttle				1	A,B,C
27	62976A		. Needle - Metering				1	A,B,C
28	62291A		. Shaft Assy - Throttle				1	A,B,C
29	62975		. Swivel - Needle				1	A,B,C
30	63019B		. Body Assy - Carburetor				1	A,B,C
31	62433B		. Stud - Carburetor				1	A,B,C
32	62295D		. Orifice - Air				1	A,B,C
33	66569		. Orifice - Fuel				1	A,B,C
34	62288A		. Bushing - Throttle shaft				1	A,B,C
35	62368		. Bushing - Throttle shaft				1	A,B,C
	67062		Seal - Air cleaner stud				1	A,B,C

* Same as Carburetor Assy #66503 (Figure 6), except includes Stud #62433B and Primer Rod #65851.

MCCULLOCH SINGLE NEEDLE CARBURETOR ADJUSTMENT

1. Turn Lo Speed screw counterclockwise until it no longer touches stop and butterfly can be completely closed.
2. Hold finger against closed butterfly and turn Lo Mix needle clockwise until butterfly starts to open. Turn the needle counterclockwise three turns.
3. Hold finger against closed butterfly and turn Lo Speed screw clockwise until butterfly starts to open. Turn the screw one half turn more.
4. Turn the Lo Mix needle in or out (leaner or richer) to obtain a smooth rapid acceleration. Roll the engine right and left, bar up and bar down. Check for smooth idle in all positions and adjust Lo Mix needle as necessary.
5. Set tension on the idle governor spring so that the engine idles smoothly in all positions and after any change in position. If chain moves after position change, reduce tension.
6. Adjust Hi Mix screw for maximum power under load. Make sure that when trigger is released the engine does not speed up before returning to idle. Turn screw clockwise until engine slows down immediately after trigger release. **DO NOT TOUCH LO MIX NEEDLE. ADJUST FOR HIGH SPEED OPERATION WITH HI MIX SCREW ONLY.**
7. With throttle in wide open position, adjust Hi Mix screw to set butterfly in horizontal position. Now turn screw clockwise until butterfly just starts to close.
8. Set tension on idle governor spring to hold butterfly slightly open.

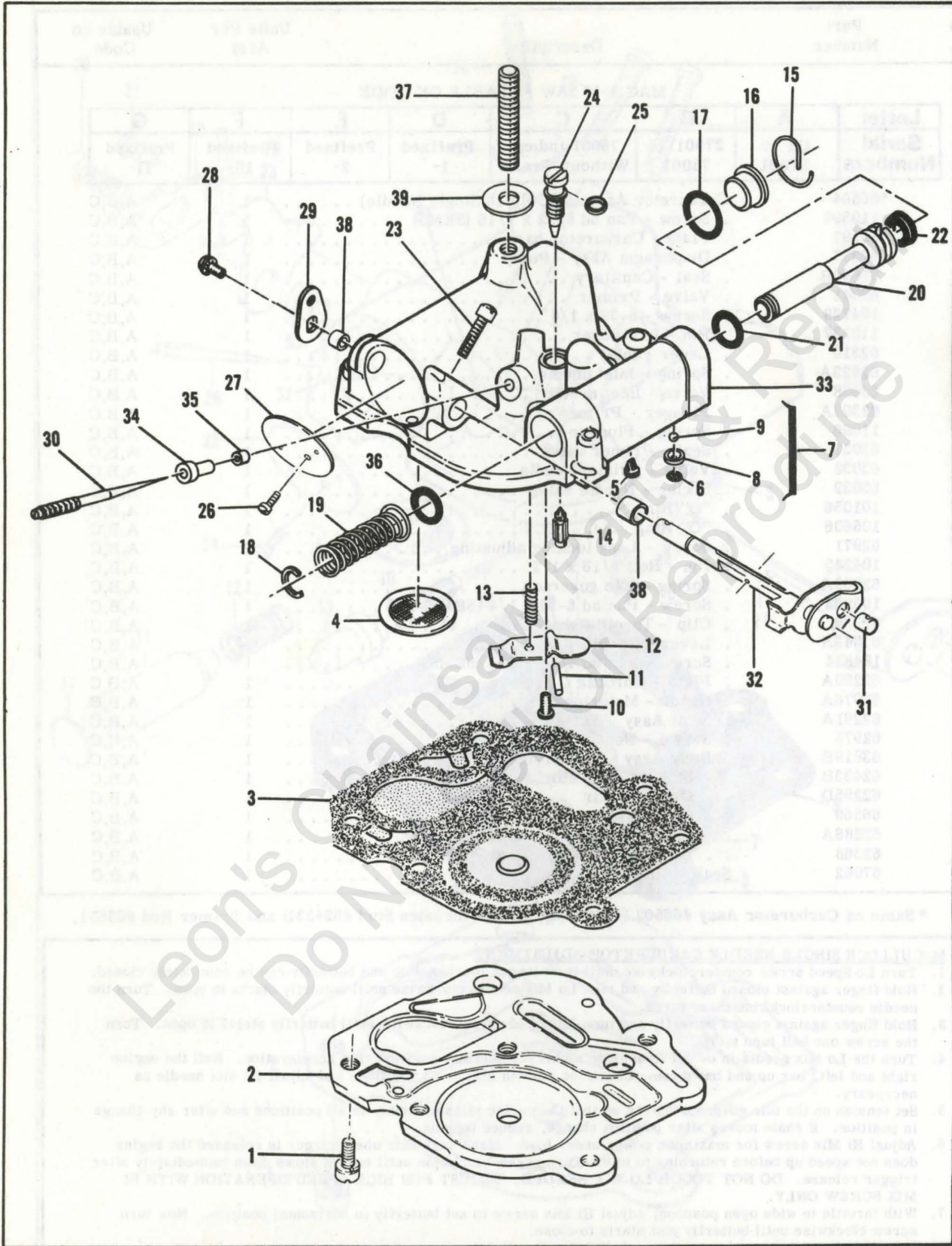

Figure 6. McCulloch Double Needle Carburetor Assembly

FIGURE 6. CARBURETOR ASSEMBLY

Item No.	Part Number	Description	Units Per Assy	Usable Code			
MAC 1-10 SAW - USABLE ON CODE							
Letter	A	B	C	D	E	F	G
Serial Numbers	Up to 27001	27001 to 75001	75001 and up Without Prefix	Prefixed 1-	Prefixed 2-	Prefixed 10-	Prefixed 11-
1	66503	Carburetor Assy (McCulloch Double Needle)		1			D,E,F
2	110397	. Screw - Pan hd 8-32 x 7/16 (SEMS)		5			D,E,F
3	65597	. Plate - Carburetor base		1			D,E,F
4	67357	. Diaphragm Assy - Pump		1			D,E,F
5	66796	. Seal - Capillary		1			D,E,F
6	63041	. Valve - Primer		1			D,E,F
7	106136	. "O" Ring		1			D,E,F
8	65868	. Set - Ball and seat		1			D,E,F
9	66153	. . Seat		1			D,E,F
10	61151	. . Ball		1			D,E,F
11	104728	. Screw - 6-32 x 1/4		1			D,E,F
12	110337	. Pin - Inlet lever		1			D,E,F
13	62310	. Lever - Inlet		1			D,E,F
14	62923A	. Spring - Inlet needle		1			D,E,F
15	63038	. Valve - Inlet needle		1			D,E,F
16	65677	. Retainer - Primer plug		1			D,E,F
17	65617	. Plug - Primer		1			D,E,F
18	105617	. "O" Ring		1			D,E,F
19	101289	. Ring - Retaining		1			D,E,F
20	65859	. Spring - Plunger		1			D,E,F
21	66552	. Plunger - Primer		1			D,E,F
22	66551	. "O" Ring		1			D,E,F
23	67116	. Seal - "V" packing		1			D,E,F
24	110483	. Screw - Adjusting		1			D,E,F
25	65445	. Needle - Main fuel		1			D,E,F
26	104001	. "O" Ring		1			D,E,F
27	104814	. Screw - 4-40 x 1/4 (SEMS)		1			D,E,F
28	62290A	. Plate - Throttle		1			D,E,F
29	104814	. Screw - 4-40 x 1/4 (SEMS)		1			D,E,F
30	65430	. Lever - Throttle		1			D,E,F
31	65431	. Needle - Metering		1			D,E,F
32	62975	. Swivel - Needle		1			D,E,F
33	65428	. Shaft Assy - Carburetor		1			D,E,F
34	66504	. Body Assy - Carburetor		1			D,E,F
35	65432	. . Orifice - Air		1			D,E,F
36	66569	. . Orifice - Fuel		1			D,E,F
37	59796	. . "O" Ring		1			D,E,F
38	65724	. . Stud - Carburetor		1			D,E,F
	62368	. . Bushing		2			D,E,F
	67062	. Seal - Air cleaner stud		1			D,E,F

MCCULLOCH DOUBLE NEEDLE CARBURETOR ADJUSTMENT

1. Turn Lo Speed screw counterclockwise until it no longer touches stop and butterfly can be completely close
2. Hold finger against closed butterfly and turn Lo Mix needle clockwise until butterfly starts to open. Turn it needle counterclockwise two and one half turns.
3. Hold finger against closed butterfly and turn Lo Speed screw clockwise until butterfly starts to open. Turn the screw clockwise one half turn more.
4. Turn Hi Mix needle clockwise until resistance is felt, then turn the needle counterclockwise two full turns
5. Turn the Lo Mix needle to obtain smooth rapid acceleration every time without faltering. Check for smooth idle for all positions of the saw and readjust the Lo Mix needle if necessary.
6. Adjust Hi Mix needle for maximum power under load. Turn the needle in for leaner and out for richer mixture. Do not adjust the needle for leaner mixture than necessary to obtain smooth, even running under a cutting load.

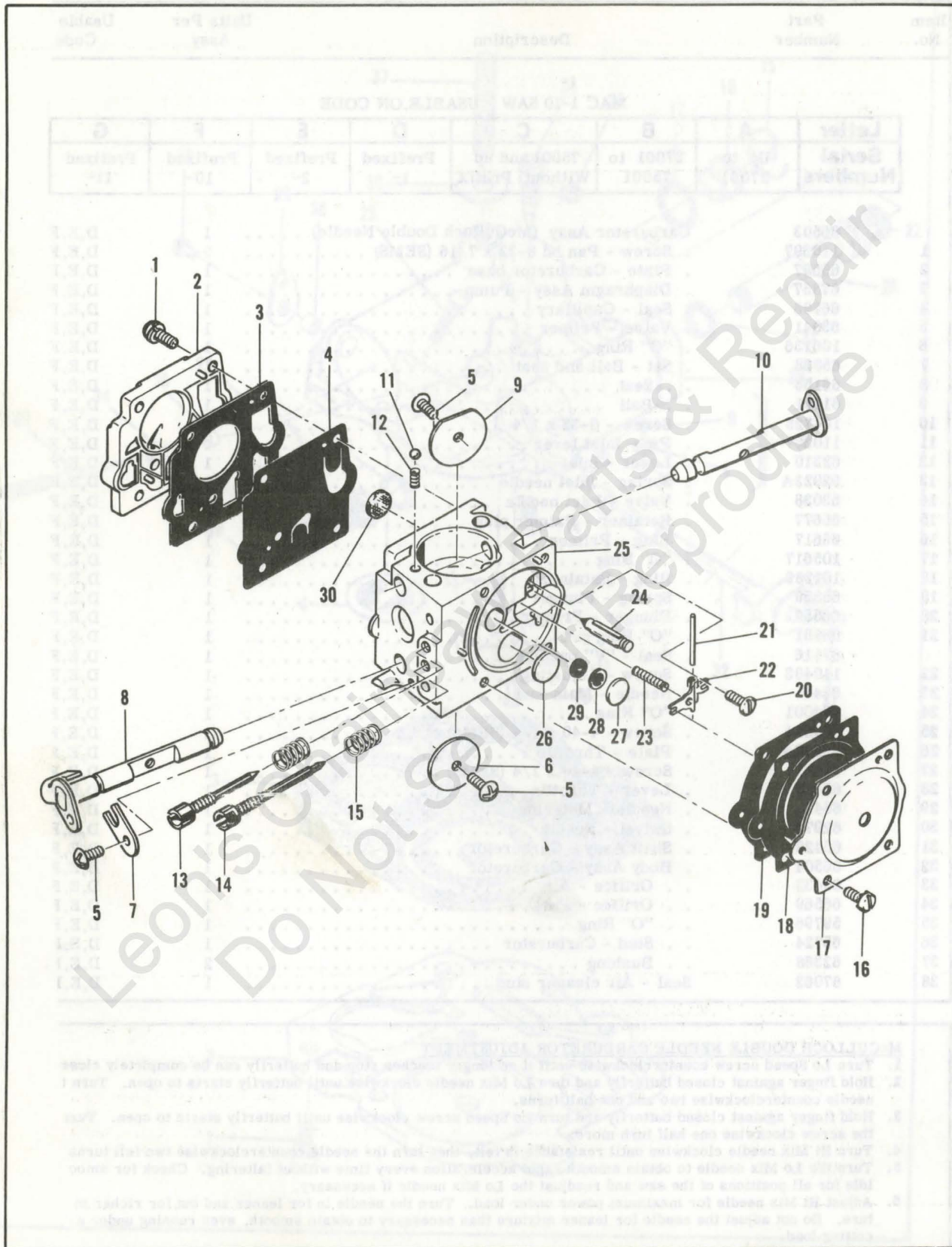

Figure 7. McCulloch SDC-2 Carburetor Assembly

FIGURE 7. CARBURETOR ASSEMBLY

Item No.	Part Number	Description	Units Per Assy	Usable on Code				
MAC 1-10 SAW - USABLE ON CODE								
	Letter	A	B	C	D	E	F	G
	Serial Numbers	Up to 27001	27001 to 75001	75001 and up Without Prefix	Prefixed 1-	Prefixed 2-	Prefixed 10-	Prefixed 11-
1	67379	Carburetor Assy (McCulloch SDC-2)		1				G
	67501	. Screw - Pump cover		4				G
2	83760	. Cover - Pump		1				G
3	* 67495	. Gasket - Cover		1				G
4	* 83114	. Diaphragm - Fuel pump		1				G
5	* 47690	. Screw - Plate		3				G
6	67487	. Plate - Throttle		1				G
7	67489	. Clip - Shaft		1				G
8	67486	. Shaft Assy - Throttle		1				G
9	67490	. Plate - Choke		1				G
10	67488	. Shaft Assy - Choke		1				G
11	* 100302	. Ball - Choke friction		1				G
12	* 67504	. Spring - Choke		1				G
13	* 67506	. Needle - High speed		1				G
14	* 67505	. Needle - Idle		1				G
15	* 67502	. Spring - Needle		2				G
16	70798	. Screw - Diaphragm cover		4				G
17	83761	. Cover - Diaphragm		1				G
18	* 67499	. Diaphragm - Metering		1				G
19	* 67496	. Gasket - Diaphragm		1				G
20	* 67500	. Screw - Lever pin		1				G
21	* 67508	. Pin - Lever		1				G
22	* 67509	. Lever - Metering		1				G
23	* 67503	. Spring - Lever		1				G
24	* 67491	. Valve - Needle		1				G
25	67483	. Body Assy - Carburetor		1				G
26	* 71690	. Plug - 3/8		1				G
27	* 69506	. Plug - 5/16		1				G
28	69203	. Seat Assy		1				G
29	69204	. Valve		1				G
30	* 67507	. Screen - Fuel		1				G
	* 67482	Gasket Set						G
	67481	Repair Kit						G

* Indicates parts included in Repair Kit, P/N 67481

MCCULLOCH SDC-2 CARBURETOR ADJUSTMENT

- Carefully turn both the high speed and idle needles clockwise until resistance is felt, then turn both needles counterclockwise one full turn.
- With engine warmed up, adjust the idle speed screw in or out until the engine idles just below clutch engagement speed.
- Adjust the idle mixture needle in or out (leaner or richer) to obtain smooth, rapid acceleration every time without faltering. If necessary, readjust the idle speed screw.
- Adjust the high speed mixture needle for maximum power under load. Turn the needle in for leaner and out for richer mixture. Do not use any leaner setting than necessary to obtain smooth, even running when cutting wood.

MAC 1-10

FIGURE 7. CARBURETOR ASSEMBLY

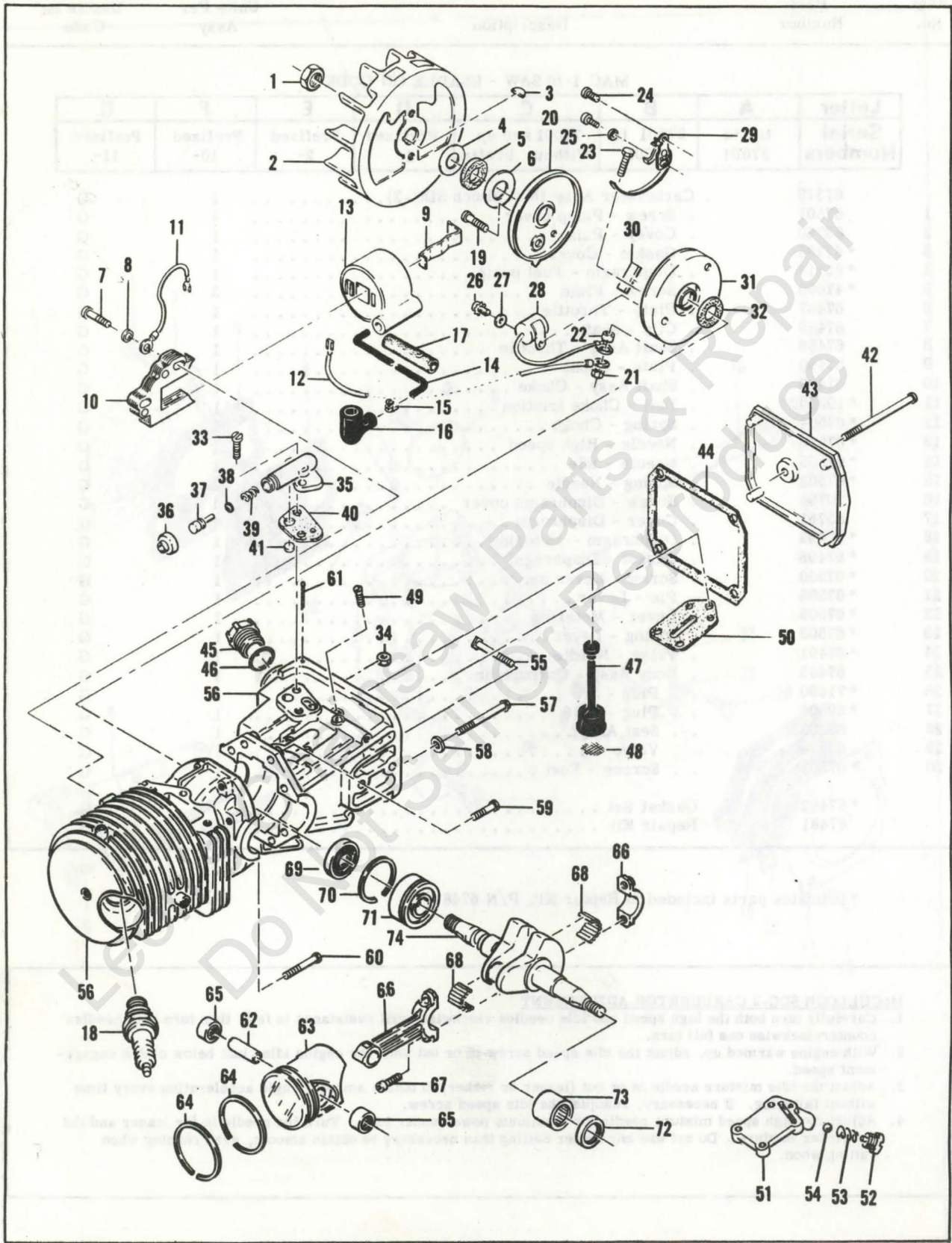

Figure 8. Powerhead Assembly

FIGURE 8. POWERHEAD ASSEMBLY

Item No.	Part Number	Description	Units Per Assy	Usable on Code			
MAC 1-10 SAW - USABLE ON CODE							
Letter	A	B	C	D	E	F	G
Serial Numbers	Up to 27001	27001 to 75001	75001 and up Without Prefix	Prefixed 1-	Prefixed 2-	Prefixed 10-	Prefixed 11-
1	101391	Nut - Hex 3/8-24				1	All
2	61737A	Flywheel Assy				1	All
3	103879	Key - Woodruff				1	All
4	67057	Washer - Thrust				1	G
5	67056	Seal				1	G
6	67054	Washer - Thrust				1	G
7	101965	Screw - Fil hd 10-24 x 7/8 (SEMS)				2	A,B,C,D,E,F
	110127	Screw - Hex hd 10-24 x 7/8 (SEMS)				2	G
8	100002	Washer - #10				2	A,B
	100003	Washer - #10				2	C,D,E,F,G
9	51253	Retainer - Coil				1	All
10	68164	Lamination Assy				1	All
11	62819	Wire Assy - Ground				1	All
12	69344	Wire Assy - Primary				1	All
13	69798	Coil & Terminal Assy				1	All
14	69966	. Wire Assy - Spark plug				1	All
15	62932	. . Connector				1	All
16	62926	. . Boot				1	All
17	67127	. . Sleeve				1	All
18	63097	Spark Plug				1	All
19	110349	Screw - Rd hd 8-32 x 3/4				1	All
20	62362	Cover - Breaker box				1	All
21	100298	Nut - Hex 6-32				1	All
22	62365	Spacer - Breaker screw				1	All
23	110346	Screw - Hex hd 6-32 x 3/4				1	All
24	100934	Screw - Rd hd 8-32 x 3/8				2	All
25	105976	Washer - #8				1	All
26	105249	Screw - Rd hd 8-32 x 3/8 (SEMS)				1	All
27	100080	Washer - #8				1	G
28	61650	Condenser				1	All
29	62363	Breaker Assy				1	All
30	54184	Wiper				1	All
31	62361	Box - Breaker				1	All
32	67051	Seal				1	G
33	110623	Screw - Hex hd 8-32 x 1/2				2	All
34	100955	Nut - Hex 8-32				1	All
35	62261A	Housing - Pump				1	All
36	62262	Cap - Housing				1	All
37	62266	Plunger - Pump				1	All
38	101056	"O" Ring				1	All
39	66687	Spring				1	All
40	62230	Gasket				1	All
41	62909	Valve				1	All
42	110291	Screw - Pan hd 10-24 x 2-5/8				1	All
43	63072	Cover - Oil tank				1	All
44	62116	Gasket - Cover				1	All
45	57129A	Cap - Oil tank				1	All
46	101148	"O" Ring				1	All
47	62123B	Hose Assy - Oil				1	All
48	51506	. Screen - Hose				1	All
49	110333	Screw - Oval hd 8-32 x 1/2				3	All
50	62274	Gasket - Pulse pump				1	All
51	68711	Body Assy - Check valve				1	All
52	68714	. Screw - Special				1	All

FIGURE 8. POWERHEAD ASSEMBLY (CONTINUED)

Item No.	Part Number	Description	Units Per Assy	Usable on Code
53	63034	. Spring - Check valve	1	All
54	100071	. Ball	1	All
55	62065	Bolt - Bar mounting	1	All
56	67908	Crankcase Assy	1	All
57	62105	. Screw Assy - Sealing	4	All
58	62842	. . Washer - Sealing	4	All
59	110288	. Screw Assy - Hex hd 8-32 x 3/4 (SEMS)	3	All
60	110618	. Screw Assy - Hex hd 8-32 x 1-3/8 (SEMS)	1	All
61	100010	. Pin - Cotter	1	All
62	61649	Pin - Piston	1	All
63	69212	Piston Assy (Standard)	1	All
64	62814	. Ring Set - Piston (Standard)	1	All
65	103512	. Bearing - Needle	2	All
66	65401	Connecting Rod Assy	1	All
67	61627A	. Screw - Skt hd 8-36 x 1/2	2	All
68	63225	. Roller - Needle (Set of 20)	1	All
69	61618	Oil Seal	1	All
70	110276	Retainer - Bearing	1	A,B
	63464	Ring - Snap	1	C,D,E,F,G
71	110348	Bearing - Ball	1	A,B
	63429B	Bearing - Ball	1	C,D,E,F,G
72	110260	Oil Seal	1	All
73	104357	Bearing - Needle	1	All
74	* 63336	Crankshaft	1	All

* See Service Bulletin 1464

Leon's Chainsaw Parts & Repair
Do Not Sell Or Reproduce

ACCESSORIES

Part Number	Description	Usable on Code
69210	Piston Assy - 0.020 in. oversize	All
62813	. Ring Set - 0.020 in. oversize	All
103512	. Bearing - Needle (2)	All
69211	Piston Assy - 0.030 in. oversize	All
62812	. Ring Set - 0.030 in. oversize	All
103512	. Bearing - Needle (2)	All
63432	Spark Plug - AC CS 42T	All
65778	Spark Plug - AC CS 41T	All
65529	Kit - Reed Spark Arrester	All
69058	Kit - Wrap-around frame	All
63341A	Kit - Spike	All
65325	Baffle - Alternate	All
65712	Guide - Timing	All
63746	Scrench	All
62827	Wrench - Screwdriver	All
66285	Manual - Owner's	D,E,F
83434	Manual - Owner's	G
63084	Manual - Shop	All

40:1 TWO-CYCLE MOTOR OIL

Reduces smoke, carbon and engine wear.



- 6 oz. can #78960
- 6-pack #78961
- 16 oz. can #78963
- 6-pack #78964
- 1 qt. bottle #110626

CHAIN, BAR AND SPROCKET OIL

Specially designed for extra lubrication of bars and chains.



- 1 qt. bottle #110631
- Case of 24 #110632

BAR GUARDS



Black Polyvinylchloride

Protect bar and chain from accidental damage.

- (A) for wide bars #56927
- (B) narrow bars #64930



Rigid Yellow Plastic

- (C) MAC10-16, 20" #66544
- (D) PM6-12, 16" #83124

LOCQUIC AND

Primer, Cleans, degreases, and accelerates curing.

- 7-1/2 oz. spray can. #69794



LOCTITE

Sealant, bonding agent

- 10cc plastic bottle #67537



SPRAY PAINT

Black

- 12 oz. can #103503
- Case of 12 #103400



Yellow

- 12 oz. can #102249
- Case of 12 #102464

CHAIN SHARPENING TOOLS

The ● shows which tools are used on chains

	S-25	SM-57	S-40	S-80	S-90
McCULLOCH FILES					
1/8" round	●				
5/32" round	●	●			
3/16" round		●			
7/32" round			●		
1/4" round				●	
9/32" round					●
8" flat	●	●	●	●	●
6" flat safety	●	●	●	●	●
FILE GUIDE & FILE					
#67750 (1/8" round)	●				
#60950 (7/32" round)			●		
(Also holds 3/16 and 1/4" round)				●	
DEPTH GAUGE TOOLS					
#56218 .025-.040"			●	●	●
#56241 .045-.060"			●	●	●
#64198 .035-.060"			●		
#64359 .045-.050"			●		
#67688 .015-.020"			●		
#67680 .025-.030"			●		
FILE-N-JOINT Assures correct filing angle, height.					
#61034	●	●	●	●	●

"BREAK ALL" CHAIN BREAKER

Required when repairing chain.

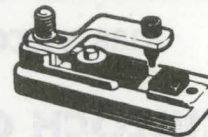

- #61753
- Instructions included.

The information contained in this Master Illustrated Parts List is based on original Illustrated Parts Lists, Engineering Records and the Master Parts Price List and is accurate to the best of our knowledge.

Each chain saw model is given a code letter. Whenever the code letter appears in the right hand column, the part is used on the engines of the model for which the code letter stands. When a part is used on all models covered in the Master Illustrated Parts List, the word "All" appears in the right-hand column instead of the code letters.

Names of parts have been checked and made to agree with the names given in the Master Parts Price List except in a very few cases where additional nomenclature was required.

The illustrations of the individual parts do not necessarily picture all the differences between parts with the same item number because the illustrations would be too complicated for use if they did. Instead, the illustration shows a representative part for each item number.

1 McCULLOCH



MANUFACTURING • SALES • SERVICE •

McCULLOCH CORPORATION

6101 WEST CENTURY BLVD., LOS ANGELES, CALIFORNIA 90045

INTERNATIONAL DIVISIONS:

LOS ANGELES, CALIF., P.O. BOX 45466

SINGAPORE, 431-432 PEOPLE'S PARK COMPLEX

McCULLOCH OF CANADA LTD.

6338 VISCOUNT ROAD, MALTON, ONTARIO, CANADA

McCULLOCH OF EUROPE, N. V.

GEERDEGEM SCHONENBERG, 299 2800 MECHELEN, BELGIUM

McCULLOCH OF AUSTRALIA PTY., LTD.

P.O. BOX 223, SEVEN HILLS, N.S.W. 2147, AUSTRALIA