

ILLUSTRATED PARTS LIST

MODELS	SERIAL NUMBER PREFIX	MODELS	SERIAL NUMBER PREFIX
600016J	14-	600016R	14-
600016M	14-	600016S	14-

McCulloch chain saws are identified by a model number (in this instance, 600016) followed by a suffix letter (A, B, C, etc.) stamped on the identification plate attached to the saw. Suffix letters denote variations in parts or assemblies in the manufacture of the saw.

Part numbers listed in this I.P.L. which have a suffix letter or letters following the description, indicate the part is used only on the model(s) identified by the letter or letters.

Part numbers and descriptions without suffix letter or letters apply to all versions of the chain saw model.

Part numbers which have one or more dots (.) preceding their descriptions may be ordered individually, but they are also included in the kit or assembly whose description begins directly above the dot(s).

Part numbers in this IPL which were not in the previous IPL covering these saws, are indicated by a dash (-) preceding the new part number.

The policy of McCulloch is one of continual improvement in design, manufacturing and engineering advancement wherever possible to assure still finer two-cycle power tools. Hence, specifications, equipment, colors, design and manufacturer's suggested list prices are subject to change without notice and McCulloch reserves the right to make such changes without prior notification or obligation to backfit or supply backfit components for units previously shipped from the factory.



April 1983

- CONTENTS -

	Page
Figure 1. General	2
Figure 2. Carburetor Assembly	4
Figure 3. Powerhead Assembly	5
Figure 4. CHAIN BRAKE Assembly	7
Bar & Chain Combinations	3
Service Specifications	3
Tools & Accessories	7



EAGER BEAVER

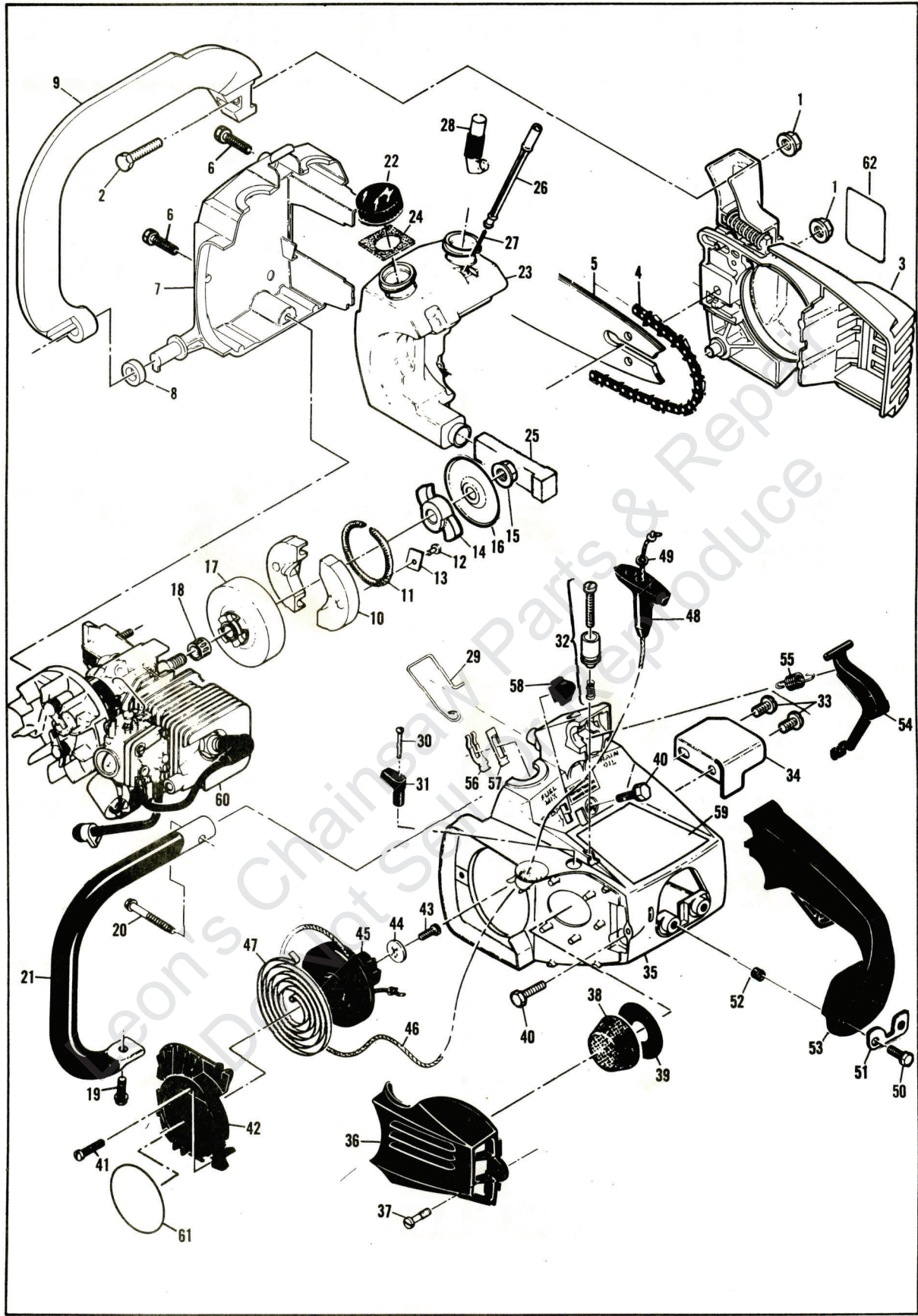

Figure 1. General

EAGER BEAVER

Figure 1. General

ITEM NO.	PART NUMBER	DESCRIPTION	UNITS PER ASY.
1	216256	Nut-Hx 1/4-28	2
2	216276	Screw-Hx hd 1/4-28 x 3/4	1
3	- -	CHAIN BRAKE Asy (Fig. 3)	
4	- -	Chain Asy (See below)	
5	- -	Bar (See below)	
6	110639	Screw-Hx hd 12-24 x 1	2
7	214718	Cover-Fuel & oil tank	1
8	93194A	Washer-Rubber	1
9	92479	Lever-Handguard	1
10	213278	Kit-Clutch	1
11	93608	. Spring Assembly	1
12	110957	. Rivet	2
13	85064	. Plate	2
14	94247	. Kit-Rotor	1
15	94244	. . Nut-Clutch	1
16	94243	. . Plate-Dust	1
17	215252	Drum/Spkt/Brng Asy	1
18	91222	. Kit-Needle bearing	1
19	110953	Screw-Hx hd 12-24 x 5/8	1
20	110686	Screw-Hx hd 13-16 x 2	1
21	214505	Frame & Grip Asy	1
22	216668	Cap-Fuel & Oil (unvented)	2
23	216715	Fuel & Oil Tank Asy	1
24	91148	. Seal-Fuel vent	1
25	84956	. Pickup-Fuel	1
26	213906	. Piston-Manual oiler	1
27	83946	. Spring-Piston	1
28	85557	. Body-Oiler	1
29	84611	Rod-Manual oiler	1
30	110672	Screw-Oval hd 4-40 x 1	1
31	83870	Knob-Choke	1

ITEM NO.	PART NUMBER	DESCRIPTION	UNITS PER ASY.
32	- -	Throttle Latch Asy (Fig. 3, 4)	
33	110807	Screw-Pn hd 8-32 x 5/16	2
34	93290	Deflector-Sawdust	1
35	215962	Shroud	1
36	91853	Cover-Air cleaner	1
37	91796	. Screw-Air cleaner	1
38	91460	Filter-Air	1
39	84918	Washer-Air seal	1
40	110953	Screw-Hx hd 12-24 x 5/8	3
41	110959	Screw-Hx hd 8-32 x 1/2	3
42	90425	Cover-Starter	1
43	110041	Screw-Pn hd 8-32 x 1/2	1
44	68497	Washer-Special	1
45	213261	Drum/Rope Asy	1
46	83203	. Rope-Starter	1
47	83078	Spring-Rewind	1
48	91255	Kit-Starter handle	1
49	105490	. Washer-Starter handle	1
50	110953	Screw-Hx hd 12-24 x 5/8	2
51	84520A	Plate-Washer	1
52	84519	Sleeve-Handle	2
53	95768	Kit-Handle	1
54	93869	. Trigger-Throttle	1
55	83940	Spring-Trigger	1
56	83935	Contact-Switch	1
57	83936	Protector-Switch	1
58	83934	Button-Switch	1
59	215960	Nameplate	1
60	- -	Powerhead Asy (Fig. 4)	
61	216218	Decal	1
62	216219	Decal	1

Bar & Chain Combinations

214233	Bar - 10" Mini Pro
215250	Bar - 10" Mini Mac
214918	Chain Assembly - 10" MM 370G
214923N	Chain Assembly - 10" MP 370G
214234	Bar - 12" Mini Pro

214921N	Chain Assembly - 12" PM 370G
214916N	Chain Assembly - 12" MM 370G
214235	Bar - 14" Mini Pro
214913N	Chain Assembly - 14" MM 370G

Service Specifications

Displacement	2.0 cu. in.
Bore and Stroke	1.430 x 1.201 in. (36.5 x 30.5 mm)
Bearings	Main: Needle Conn. Rod: Needle
Intake System	3rd Port, Piston Timed
Fuel Tank Capacity	10.8 fl. oz. (320 cc)
Chain Oiler Capacity	3.2 fl. oz. (95 cc)
Clutch Engaging Speed	3800 to 4200 rpm
Idle Speed	2700 to 2900 rpm
Ignition	Magneto

Carburetor	Diaphragm Type, 2 needle
Fuel Type	Regular grade, leaded
Fuel/Oil Mixture	40:1 w/ McCulloch Oil
Filter System - Fuel	Felt Fuel Filter
Filter System - Air	Flocked Screen Filter
Lamination Gap	.008 to .012" (.203 to .304 mm)
Breaker Point Gap	.018" (.457 mm)
Timing	26° B.T.D.C.
Piston Rings	2 Cast Iron Compression
Weight (w/ bar & chain):	
Eager Beaver....	9.6 lbs. (4.3 kg)

Figure 2. Carburetor Assembly

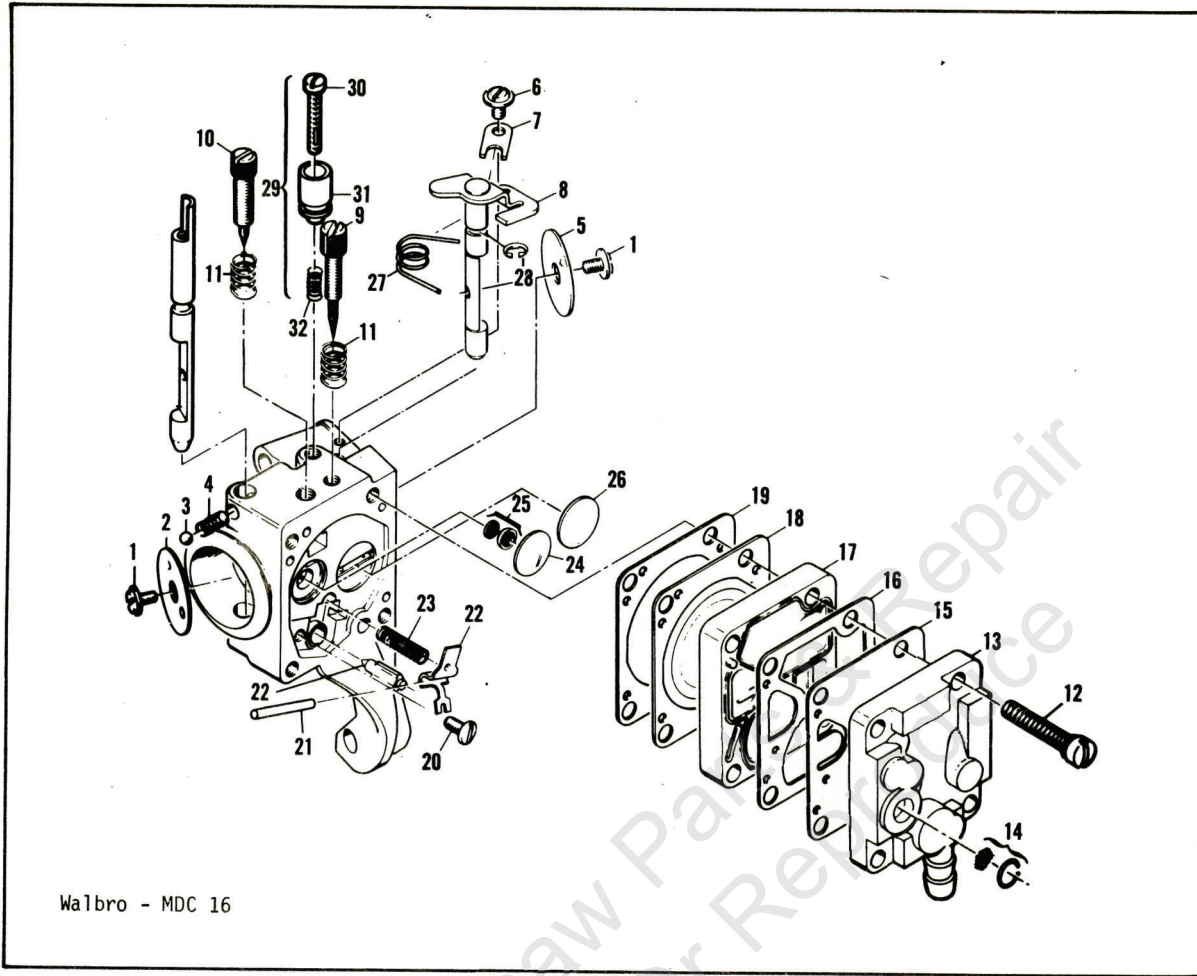

ITEM NO.	PART NUMBER	DESCRIPTION	UNITS PER ASY.
	214082B	Carburetor Asy-Walbro MDC 16	1
1	--	. Screw-Plate	2
2	--	. Plate-Choke	1
3	--	. Ball-Choke friction	1
4	--	. Spring-Choke friction	1
5	--	. Plate-Throttle	1
6	--	. Screw-Clip	1
7	--	. Clip-Throttle shaft	1
8	--	. Shaft Asy-Throttle	1
9	--	③ Needle-Idle	1
10	--	③ Needle-High speed	1
11	--	③ Spring-Needle	2
12	--	. Screw Asy-Body	4
13	--	. Cover Asy-Pump	1
14	--	① . Kit-Vent screen	1
15	--	②① . Diaphragm-Fuel pump	1
16	--	②① . Gasket-Pump diaphragm	1

ITEM NO.	PART NUMBER	DESCRIPTION	UNITS PER ASY.
17	--	. Body-Fuel pump	1
18	--	②① . Diaphragm-Metering	1
19	--	②① . Gasket-Diaphragm	1
20	--	① . Screw-Lever pin	1
21	--	① . Pin-Lever	1
22	--	① . Kit-Needle & lever	1
23	--	① . Spring-Lever	1
24	--	① . Plug-Welsh 7/16	1
25	--	① . Kit-Check valve	1
26	--	① . Plug-Welsh 1/2	1
27	--	. Spring-Throttle return	1
28	--	. Ring-Retaining	1
29	93437	Latch Asy-Throttle	1
30	--	. Screw-Long lock	1
31	--	. Latch-Throttle	1
32	--	. Spring-Compression	1

- ① Contained in Repair Kit, P/N 217084.
- ② Contained in Gasket/Diaphragm Kit, P/N 216727.
- ③ Contained in Needle/Spring Kit, P/N 217083.

NOTE: Items not listed with part numbers, except for those contained in the three kits, are shown for identification and disassembly sequence purposes only. They are NOT available as service parts. The only items available as service parts are the three kits and items with part numbers.

Figure 3. CHAIN BRAKE Assembly

EAGER BEAVER

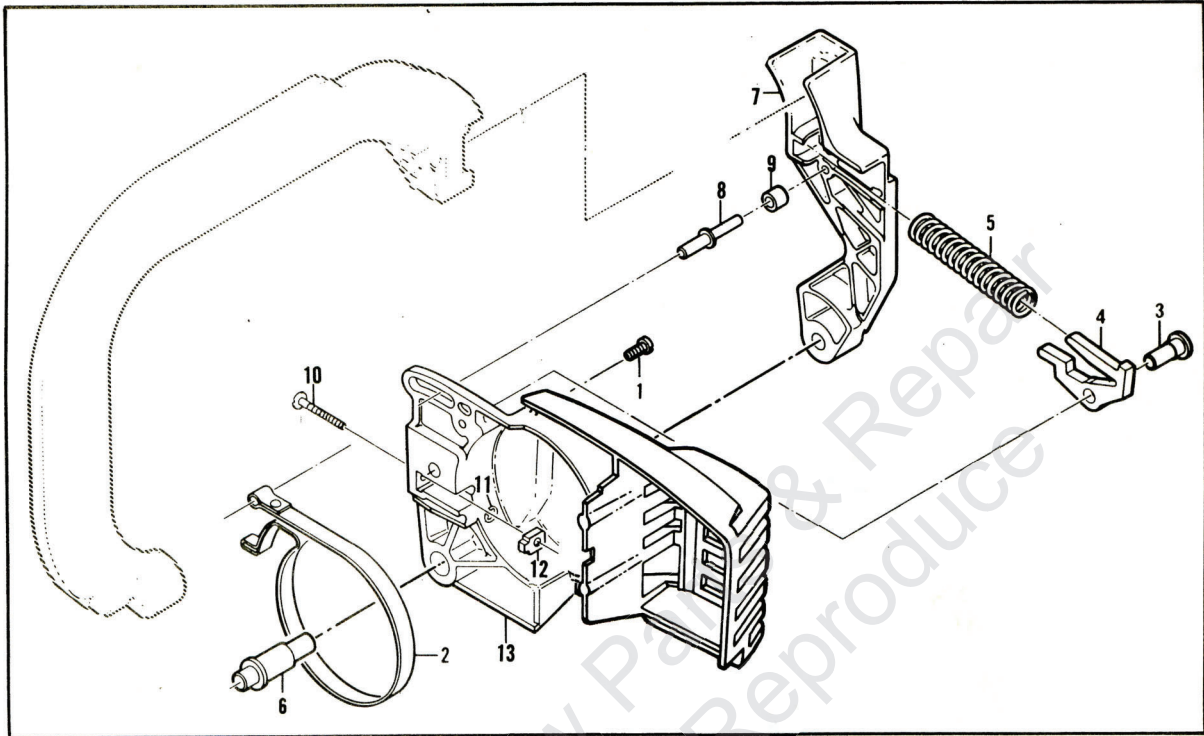

ITEM NO.	PART NUMBER	DESCRIPTION	UNITS PER ASY.
	216417	CHAIN BRAKE Assembly	
1	111047	. Screw - Pan hd 8-32 x 5/8	1
2	94709	. Band - Brake	1
3	93602	. Pivot - Latch	1
4	215758	. Kit - Latch	1
5	- -	. Spring - Compression	1
6	216549	. Pivot - Lever	1

ITEM NO.	PART NUMBER	DESCRIPTION	UNITS PER ASY.
7	92867	. Lever	1
8	213907	. Pin - Roller	1
9	214368	. Bearing - Roller	1
10	90658	. Screw - Adjusting	1
11	110907	. Ring - Retaining	1
12	84929	. Nut - Bar Adjusting	1
13	216414	. Housing - Brake	1

Tools & Accessories

PART NUMBER	DESCRIPTION
95169	Kit - Spark Arrester
91485	Wrench - Socket
85687	Wrench - Screwdriver
88755	Scrench
93283	Case - Carrying, 12"
214201	. Bar Guard, 12"
93090	Guide - Timing
68915A	Kit - Piston Tool
90256	Kit - Tune up
214215	Guide - File

PART NUMBER	DESCRIPTION
214211	Kit - Tool Maintenance
93900	Kit - Pressure Test
215432	Tool - Pressure Test
501334	Tester - Ignition
214194	Lubri-Gun
85702	Lubricant - Custom, 6 oz. can
85703	Lubricant - Custom, 6 oz. cans, 1-6 pack
67537	Loctite
69794	Locquic
110083	R.T.V. Sealant

EAGER BEAVER

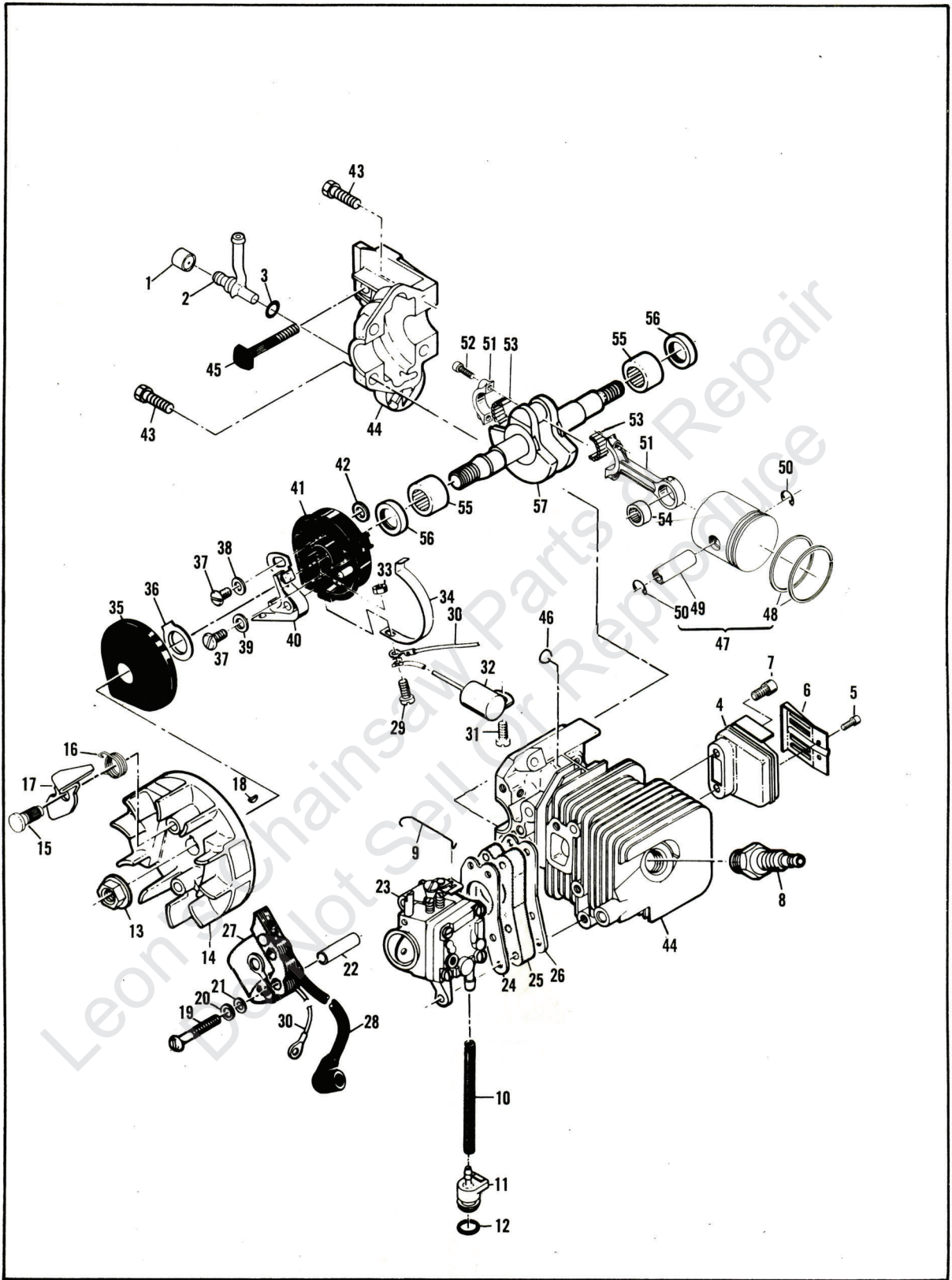

Figure 4. Powerhead Assembly.

Figure 4. Powerhead Assembly

ITEM NO.	PART NUMBER	DESCRIPTION	UNITS PER ASY.	ITEM NO.	PART NUMBER	DESCRIPTION	UNITS PER ASY.
1	86436	Valve-Manual oil pump	1	30	69344	Wire Assembly-Coil	1
2	217156	Connector-Oil pump	1	31	110041	Screw-Pn hd 8-32 x 1/2 s/t	1
3	105603	"O" Ring	1	32	85358	Condenser	1
4	215411	Muffler Assembly	1	33	100035	Nut-Hx 6-32	1
5	110681	. Screw-Skt hd 10-24 x 1/4	2	34	84502	Connector	1
6	92961	. Deflector	1	35	67841	Cover-Breaker box	1
7	215394	. Screw-Special M6	2	36	69323	Seal-Breaker box	1
8	214223	Spark Plug	1	37	110969	Screw-Hx hd 8-32 x 1/2	2
9	216039	Rod-Throttle	1	38	69322	Washer-Special	1
10	89059	Hose-Fuel	1	39	105976	Washer-#8	1
11	90660	Adaptor-Fuel hose	1	40	88811	Breaker Assembly	1
12	110908	"O" Ring	1	41	84505A	Kit-Breaker box	1
13	110961	Nut-Hx 5/16-24	1	42	92037	. Washer	1
14	94737	Flywheel/Pawl Assembly	1	43	110639	Screw-Hx hd 12-24 x 1	4
15	68796	. Pin-Pawl	2	44	215768	Kit-Cylinder	1
16	67814	. Spring-Pawl	2	45	83856	. Bolt-Bar mounting	1
17	94493	. Pawl-Starter	2	46	110914	. Plug-Cup	4
18	102164	Key-Woodruff	1	47	94662	Piston Assembly	1
19	110586	Screw-Pn hd 8-13 x 1-3/4	3	48	95143	. Set-Piston rings	1
20	105976	Washer-#8	3	49	92836	. Pin-Piston	1
21	67177	Washer-Insulating	3	50	111026	. Ring-Snap	2
22	68198	Tube-Insulating	3	51	94135	Connecting Rod Assembly	1
23	- -	Carburetor Assembly		52	94654	. Screw-Connecting Rod	2
24	68197	Gasket-Carburetor	1	53	68095	. Roller-Needle (set of 20)	1
25	214349	Insulator-Carburetor	1	54	110984	. Bearing-Needle	1
26	90714	Gasket-Insulator	1	55	213282	Bearing-Crankshaft	2
27	84957	Coil & Lamination Assembly	1	56	83859	. Seal-Crankshaft	1
28	215351	. Wire Assembly-Spark plug	1	57	91932	Crankshaft	1
29	110364	Screw-Pn hd 6-32 x 5/8	1				

Leon's Chainsaw
Do Not Sell



● MANUFACTURING ● SALES ● SERVICE ●

McCULLOCH
CORPORATION

900 Lake Havasu Ave.
Lake Havasu City, AZ 86403-2891

**FOR SERVICE-RELATED PROBLEMS,
REPAIR OR MAINTENANCE
TAKE YOUR UNIT TO THE NEAREST
AUTHORIZED McCULLOCH SERVICING
DEALER LISTED UNDER SAWS IN YOUR
TELEPHONE DIRECTORY YELLOW PAGES.**

If additional assistance is required, call this toll-free hot-line:
(800) 423-6302

Arizona residents call collect **(602) 453-3681**