

XL

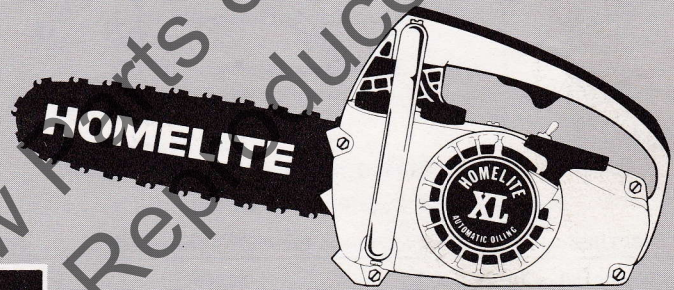

chain saw

Leon's Chain Saw Parts & Repair
Do Not Sell or Reproduce



XL CHAIN SAW

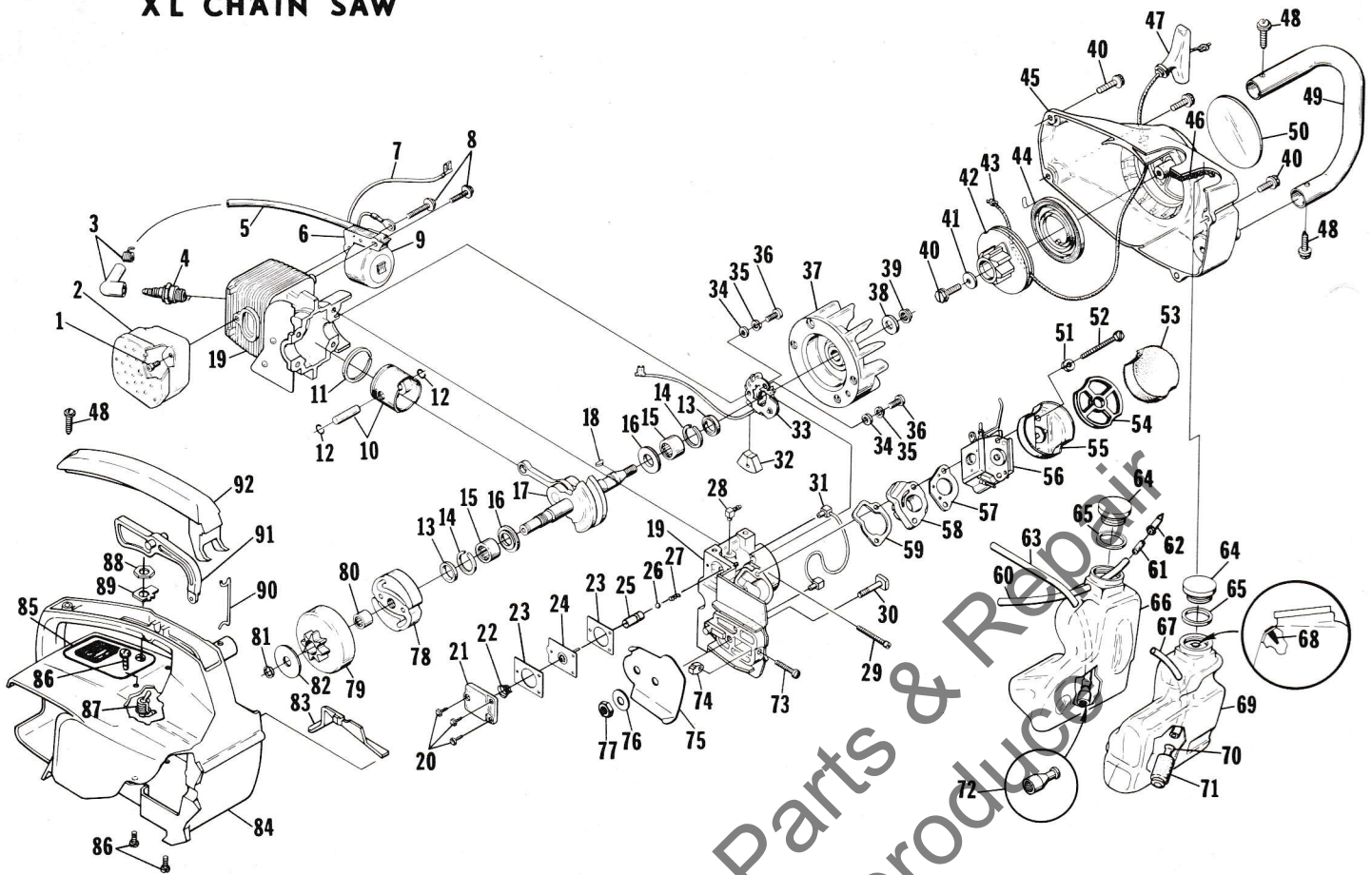

No.	Description	Part No.	Qty.	No.	Description	Part No.	Qty.
1	SCREW-soc. hd., 10-24 x 1/2	82245	1	32	SEAL-lead	69247	1
2	MUFFLER	A-69253-1	1	33	POINT SET- breaker	A-69336	1
3	TERMINAL-spark plug	A-33055	1	34	WASHER-flat	84025-1	2
4	SPARK PLUG-Champion DJ-7J	68616-S	1	35	WASHER-lock	83060	2
5	LEAD-high tension	69326	1	36	SCREW-point set	82241	2
6	CORE-coil	69324	1	37	ROTOR & STARTER PAWL	A-69297-A	1
7	LEAD-stop switch	69321	1	38	WASHER-flat	69145	1
8	SCREW-hex w/washer, 8-32 x 3/4	82248	2	39	NUT-rotor, 5/16-24	81229	1
9	COIL	69323	1	40	SCREW-hex w/washer, 10-32 x 5/8	80704	5
	RETAINER-coil (not shown)	69325	1	41	WASHER-flat	63606	1
	SHORT BLOCK	A-69394-A	1	42	PULLEY-starter	69158	1
	Includes:			43	ROPE-starter #4 30' long	69311	1
10	PISTON & PIN	A-69393	1	44	SPRING-rewind	69217	1
	Includes:			45	HOUSING-rewind starter	A-69540	1
11	PISTON RING	69312	1		Includes:		
12	RING-piston pin retaining	65261	2	46	FILTER-fuel tank valve	69443	1
13	SEAL	68519	2	47	GRIP-starter rope	69157	1
14	SPACER-seal	69407	2	*48	SCREW-pan washer hd., 10-32 x 5/8	82239	3
15	BEARING-needle	12530	2	*49	HANDLE BAR	69133	1
	BEARING-roller (optional)	68513	2	*50	DECAL-XL	69887	1
16	WASHER-thrust	69093	2	51	WASHER-lock, #10	83006-1	2
17	CRANKSHAFT	A-69132	1	52	SCREW-hex hd., 10-32 x 2-1/4	80481	2
18	KEY-magneto	69250	1	53	FILTER-air	69141	1
19	CYLINDER & CRANKCASE	A-69421-A	1	54	RETAINER-filter	69457	1
	Includes:			55	CUP-filter	69148	1
20	SCREW-pan hd., 6-32 x 3/8	80571	3	56	CARBURETOR-HDC-15	A-69319	1
21	COVER-oil pump	69224-1B	1	57	GASKET-carburetor	65016	1
22	SPRING-oil pump	69447	1	58	MANIFOLD-intake	A-69373	1
23	GASKET-oil pump	69244	2	59	GASKET-intake manifold	69143	1
24	PLUNGER-oil pump	A-69242	1	60	LINE-pressure	A-69358	1
25	BODY-oil pump	69343	1		Includes:		
26	BALL-check valve	60051	1	61	CONNECTOR-oil line	69659-1	1
27	SPRING-check valve	68570	1	62	VALVE-check	69451	1
28	FITTING-oil line	69295	1	63	LINE-oil	69345	1
29	SCREW-Sems, 8-32 x 1	88021	4	64	CAP-tank (fuel & oil)	A-69277-A	2
30	BOLT-guide bar	69195	1		Includes:		
31	LINE-oil	A-69314	1	65	GASKET	69585	1

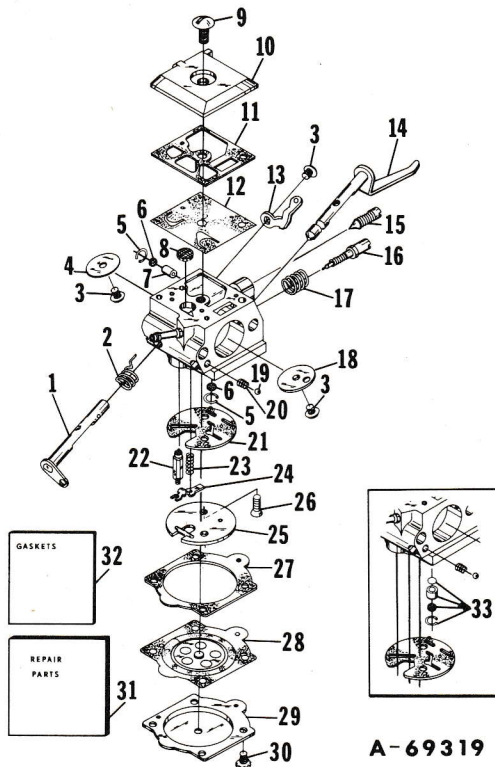

A-69319
HDC-15

Accessories

KIT-check valve repair	65386	1
Includes: VALVE-check		1
SEAT-valve		1
SCREEN-check valve	67381	1
RING-screen retaining	67360	1
PLATE-circuit (high altitude)	A-69588	1

No.	Description	Part No.	Qty.
1	SHAFT-throttle	69252	1
2	SPRING-throttle return	†69430	1
3	SCREW-valve	†67372	3
4	VALVE-throttle	67363	1
5	RING-screen retaining	†67360	2
6	SCREEN-check valve	†67381	2
7	JET-limiting	69432	1
8	SCREEN-fuel inlet	†64243	1
9	SCREW-fuel pump cover	67374	1
10	COVER-fuel pump	67361	1
11	GASKET-fuel pump	†67368	1
12	DIAPHRAGM-fuel pump	†67370	1
13	STOP-throttle	69519	1
14	SHAFT-choke	69251	1
15	NEEDLE-idle adjustment	67373	1
16	NEEDLE-main adjustment	†69431	1
17	SPRING-needle adjusting	†67377	1
18	VALVE-choke	69428	1
19	BALL-check valve	†60051	1
20	SPRING-choke friction	†64238	1
21	GASKET-circuit	†67367-A	1
22	NEEDLE-inlet	†64229	1
23	SPRING-metering lever	†67378	1
24	LEVER-metering	†67383	1
25	PLATE-circuit	69433	1
26	SCREW-circuit plate	67375	2
27	GASKET-metering diaphragm	†64231	1
28	DIAPHRAGM-metering	†67371	1
29	COVER-metering diaphragm	64224	1
30	SCREW-metering cover	64089	4
31	REPAIR KIT	69434	1
32	GASKET SET	†67369-A	1
33	KIT-check valve repair (accessory)	65386	1

† Indicates contents of Repair Kit #69434

‡ Indicates contents of Gasket Set #67369-A

No.	Description	Part No.	Qty.
66	TANK-oil	69280-1	1
67	LINE-fuel	69344	1
68	VALVE-check	69451	1
69	TANK-fuel	69281-1	1
*70	FILTER-fuel pick-up	A-69923	1
	Includes:		
*71	FILTER-felt	64083	1
72	FILTER-oil	A-68593	1
73	SCREW-adjusting fil. hd., 8-32 x 7/8	82250	1
74	PIN-adjusting	69254-1A	1
75	PLATE-guide bar	69360	1
76	WASHER-flat	69309-1	1
77	NUT-guide bar	81065-2	1
78	CLUTCH-"S"	69070-1	1
79	DRUM & SPROCKET-.250 pitch, 9 tooth	A-69587	1
	Includes:		
80	BEARING-needle	69318-1	1
81	RING-retaining clutch	69743	1
82	WASHER-thrust (clutch)	69138	1
83	COVER-air filter	69263	1
*84	HOUSING-engine	A-69944	1
	Includes:		
*85	PLATE-starting instructions	69888	1
86	SCREW-pan hd., 10-24 x 1/2	82216	4
87	SWITCH-stop (grounding)	A-63938	1
	Includes:		
88	NUT-hex	72084-A1	1
89	PLATE-"On-Off"	63910	1
90	ROD-throttle	69255-A	1
*91	TRIGGER	69874	1
*92	COVER-handle	69872	1

* Denotes new parts

Tools

PULLER-rotor	A-24747-A
Includes:	
BOLT-5/16-18 x 1-3/4 (1)	80288
NUT-hex, 5/16-18 (2)	81196
WRENCH-flat (for guide bar nut)	24814
WRENCH-hex soc., 5/32 (for 10-24 screws)	22126
WRENCH-hex soc., 9/64 (for 8-32 screws)	23528
WRENCH-socket (double end)	68651
WRENCH-spanner (clutch)	A-23696-A
Includes:	
PIN-clutch spanner (2)	23717-A

Accessories

FILTER-air	A-24779
Includes:	
FILTER-air (2)	69141
GASKET-oil pump body	69596
KIT-spark arrestor	A-69586
Includes:	
SCREW-self-tapping, #6 x 1/4 (3)	80328
LINE-fuel (10 ft. length)	69656
LINE-oil (10 ft. length)	69657
REEL-250' (starting rope) #4	68848

Paint

SPRAY CAN-black	22772
SPRAY CAN-red	23475

Leon's Chainsaw Parts & Repair
Do Not Sell or Reproduce



A **textron** DIVISION, PORT CHESTER, N.Y. 10573