

**CHAIN SAW
PARTS LIST**

XL-113

XL-114

XL-122*

HOMELITE®

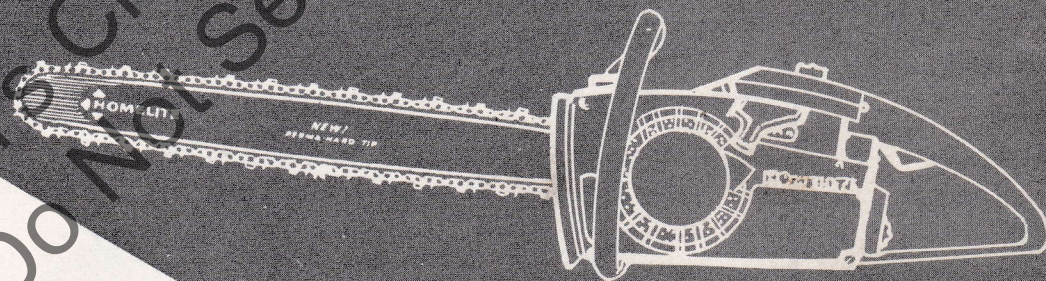

***INTERNATIONAL SALES ONLY**

Part No. 24360 Rev. 1

HOMELITE XL CHAIN SAWS

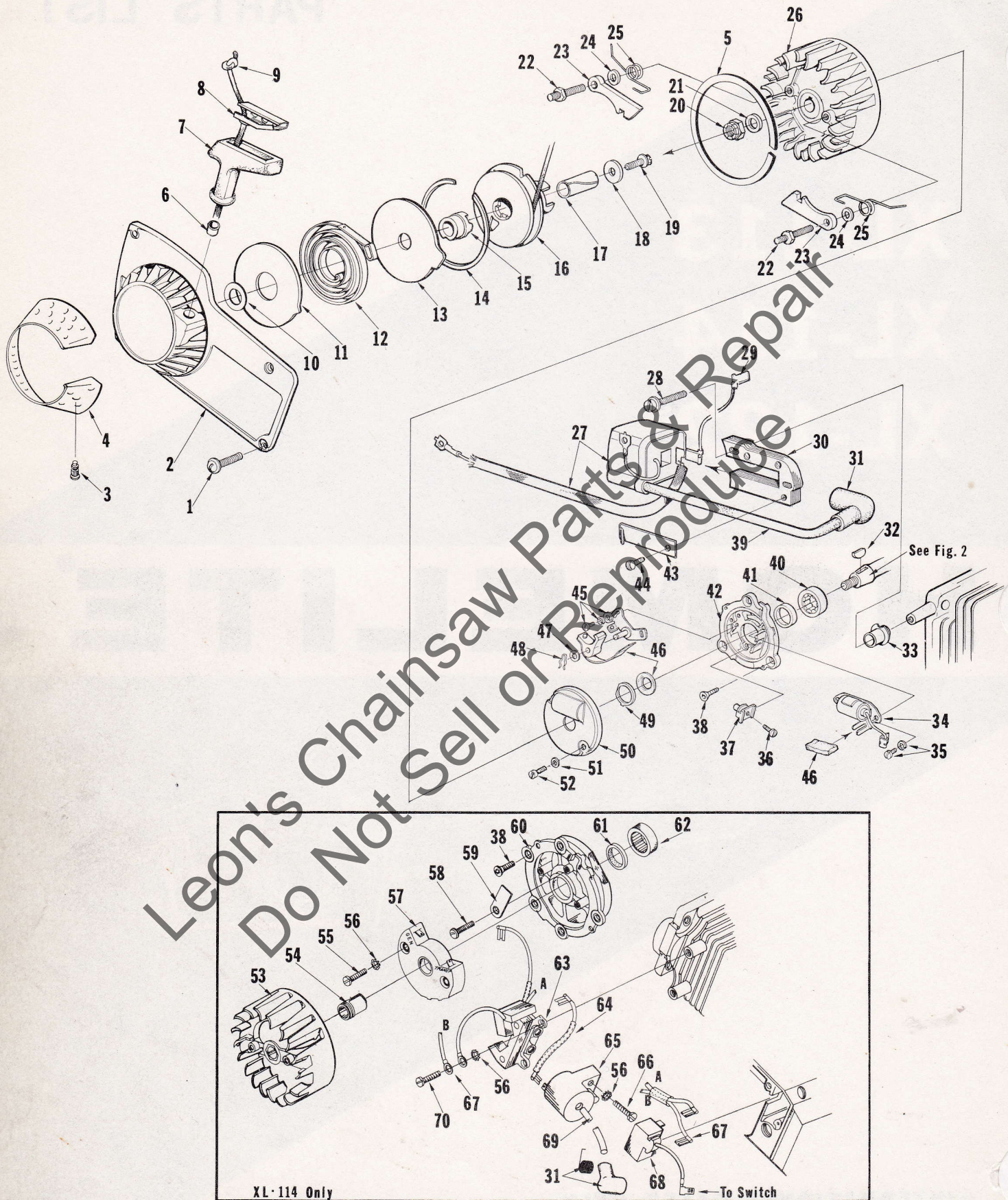

FIGURE 1

ALWAYS FURNISH MODEL AND SERIAL NUMBER WHEN ORDERING PARTS.

HOMELITE XL CHAIN SAWS

No.	Description	Part No.	XL-113	XL-114	XL-122	Qty.
1	SCREW-hex, 8-32 x 1/2	80983	x	x	x	4
2	HOUSING-fan	A-67192-A	x	x	x	1
3	Includes: STUD-drive	67191	x	x	x	4
4	SCREEN-fan housing	65491	x	x	x	1
5	RING-air flow	67222	x	x	x	1
6	BUSHING-starter rope	67177	x	x	x	1
7	GRIP-starting rope	64155	x	x	x	1
8	INSERT-rope retaining	64154	x	x	x	1
9	ROPE-starter	63869	x	x	x	1
10	WASHER	67185	x	x	x	1
11	SHIELD-spring (inner)	63713	x	x	x	1
12	SPRING-rewind	63870	x	x	x	1
13	SHIELD-spring (outer)	63714	x	x	x	1
14	RING-shield retaining	63875	x	x	x	1
15	LOCK-spring	64948	x	x	x	1
16	PULLEY & CUP ASSY.	A-63952-A	x	x	x	1
17	BUSHING-starter post	64374	x	x	x	1
18	WASHER-retaining	63606	x	x	x	1
19	SCREW-hex, 10-32 x 1/2	80648	x	x	x	1
20	NUT-lock, 5/16-24	81112	x	x	x	1
21	WASHER-flat, 5/16	84065-1	x	x	x	1
22	STUD-shoulder	63877	x	x	x	2
23	PAWL-starter	64442	x	x	x	2
24	WASHER-flat	58851	x	x	x	2
25	SPRING-starter pawl	58753-2	x	x	x	2
26	ROTOR-magneto	63637	x	x	x	1
27	COIL-ignition	64091	x	x	x	1
28	SCREW-coil core	64021	x	x	x	2
29	LEAD-ground to switch	A-63939	x	x	x	1
30	CORE-coil	54422	x	x	x	1
31	TERMINAL-spark plug	A-33055	x	x	x	1
32	KEY-woodruff	75078	x	x	x	1
33	RETAINER-lead	64301	x	x	x	1
34	CONDENSER & CLAMP	64086	x	x	x	1
35	SCREW-condenser clamp	55411	x	x	x	2
36	SCREW-terminal	64090	x	x	x	2
37	BLOCK-terminal	64088	x	x	x	1
38	SCREW-back plate retainer	65321	x	x	x	5
39	LEAD-high tension	58966	x	x	x	1
40	BEARING-roller	67395	x	x	x	1
41	SEAL	58688-A	x	x	x	1
42	PLATE-back	63624-1A	x	x	x	1
43	CLIP-coil retaining	54423	x	x	x	1
44	SCREW-coil retaining clip	58872	x	x	x	1
45	SCREW-breaker clamp	76421	x	x	x	2
46	POINT-set w/felt	A-64087	x	x	x	1
47	Includes: WASHER-post	28028	x	x	x	1
48	CLIP-post	28008	x	x	x	1
49	RETAINER-felt	64089	x	x	x	1
50	COVER-breaker box	A-63928	x	x	x	1
51	WASHER-flat, #6	84018	x	x	x	2
52	SCREW-cover	64085	x	x	x	2
53	ROTOR-magneto	67284	x	x	x	1
54	CAP-dust	64423	x	x	x	1
55	SCREW-pan, 8-32 x 5/8	82177	x	x	x	2
56	WASHER-lock, #8	83106	x	x	x	6
57	MODULE-ignition	67283	x	x	x	1
58	SCREW-pan, 6-32 x 5/16	80605	x	x	x	1
59	CLAMP-condenser lead	67285	x	x	x	1
60	PLATE-back	A-67287	x	x	x	1
61	Includes: SEAL	58688-A	x	x	x	1
62	BEARING-roller	67395	x	x	x	1
63	CORE & COIL	67277	x	x	x	1
64	LEAD-transformer	67483	x	x	x	1
65	TRANSFORMER	67275	x	x	x	1
66	SCREW-fil, 8-32 x 7/8	80183	x	x	x	2
67	LEAD-condenser	67280	x	x	x	1
68	CONDENSER	67281	x	x	x	1
69	LEAD-high tension	67484	x	x	x	1
70	SCREW-pan, 8-32 x 3/4	82178	x	x	x	2

Leon's Chain Saw Parts & Repair
Do Not Sell or Reproduce

HOMELITE XL CHAIN SAWS

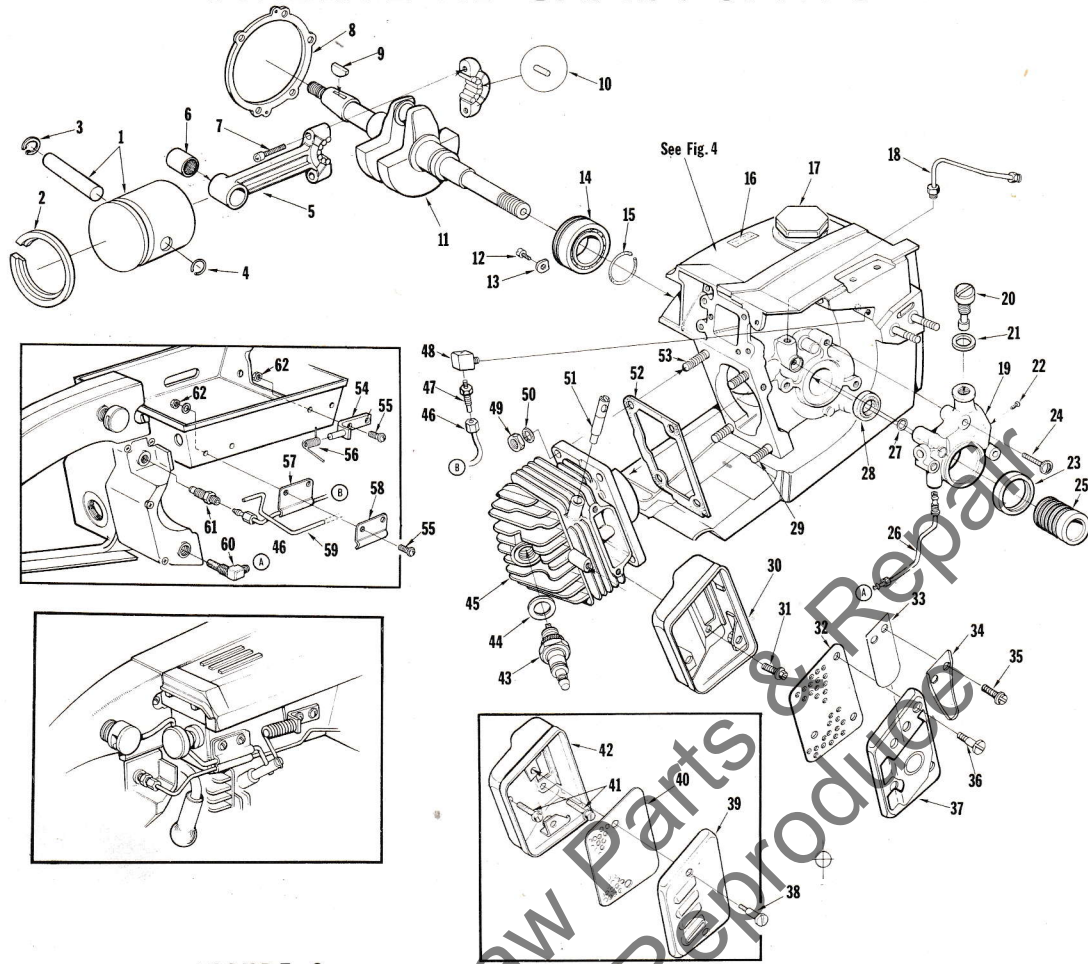

FIGURE 2

No.	Description	Part No.	XL-113	XL-114	XL-122	Qty.	No.	Description	Part No.	XL-113	XL-114	XL-122	Qty.
1	PISTON & PIN	A-67696	x	x	x	1	*34	STOP-reed	67413-1	x	x	x	1
2	Includes: PISTON RING-"L" shaped	67340	x	x	x	1	35	SCREW-pan, 8-32 x 1/4	80575	x	x	x	2
3	RING-retaining	75120	x	x	x	1	36	SCREW-shoulder	64133-A	x	x	x	3
4	RING-piston pin retaining	64813	x	x	x	1	*37	CAP-muffler	A-67527-1	x	x	x	1
5	ROD-connecting	A-67411	x	x	x	1	38	SCREW-shoulder (See Note 1)	64133-A	/	/	/	2
6	Includes: BEARING-needle	67408	x	x	x	1	39	SCREW-muffler (See Note 1)	64125	/	/	/	1
7	SCREW	80889	x	x	x	2	40	BAFFLE-muffler (See Note 1)	64126	/	/	/	1
8	GASKET-crankcase	63361-A	x	x	x	1	41	SCREW-hex, 12-24 x 1/2 (See Note 1)	80821	/	/	/	3
9	KEY-woodruff	75078	x	x	x	1	42	BODY-muffler (See Note 1)	A-64130	/	/	/	1
10	ROLLER-needle (set of 3)	A-67437	x	x	x	1	43	SPARK PLUG	63547-S	x	x	x	1
11	CRANKSHAFT	63204-1	x	x	x	1	44	Includes: GASKET	25038	x	x	x	1
12	SCREW-bearing retainer	59704	x	x	x	2	45	CYLINDER	A-64542-2A	x			1
13	WASHER-special	63905	x	x	x	2		CYLINDER	A-67189-1		x		1
14	BEARING-ball	63865-S	x	x	x	1		CYLINDER	64405-1			x	1
15	RING-retaining	58319-A	x	x	x	1	46	LINE-oil (manual)	A-67079	x	x	x	1
16	DECAL	64144	x	x	x	1	47	FITTING-straight	65696	x	x	x	1
17	CAP-fuel filler	A-67501	x	x	x	1	48	CONNECTOR-elbow	31734	x	x	x	1
18	LINE-oil (auto. upper)	A-63919	x	x	x	1	49	NUT-hex, 1/4-28	81065-2	x	x	x	4
19	PUMP-automatic oil	A-67023	x	x	x	1	50	WASHER-lock, 1/4	83009	x	x	x	4
20	Includes: SCREW-cam	64102-A	x	x	x	1	51	PIN-compression release	A-67482	x	x		1
21	GASKET	59736	x	x	x	1	52	GASKET-cylinder	65829	x	x	x	1
22	SCREW-pan, 4-40 x 1/4	80919	x	x	x	2	53	STUD-cylinder (long)	63868	x	x	x	1
23	SEAL-felt	64393	x	x	x	1	54	PIVOT PIN & BRACKET ASSY.	A-64656-2	x	x		1
24	SCREW-pan, 8-32 x 7/8	80568	x	x	x	3	55	SCREW-pan, 6-32 x 3/8	80571	x	x		4
25	WORM-oil pump	63228	x	x	x	1		SCREW-pan, 6-32 x 3/8	80571			x	2
26	LINE-oil (auto. lower)	A-63947	x	x	x	1	56	SPRING-relief valve	64653	x	x		1
27	"O" RING	59074	x	x	x	1	57	CLAMP-oil	65949-2	x	x	x	1
28	SEAL	58308-A	x	x	x	1	58	CLAMP-lever	64655-2	x	x		1
29	STUD-cylinder (short)	55871	x	x	x	3	59	LEVER-relief valve	64654-B	x	x		1
*	MUFFLER-reed (complete)	A-67888-A	x	x	x	1	60	FILTER-oil	A-64741	x	x	x	1
*30	Includes: BODY-muffler	A-67446-1A	x	x	x	1	61	VALVE-check	A-65948	x	x	x	1
31	SCREW-hex, 12-24 x 1/2	80821	x	x	x	3	62	NUT-flexlock, 6-32	81126	x	x		4
*32	BAFFLE-muffler	67450	x	x	x	1		NUT-flexlock, 6-32	81126			x	4
*33	REED-muffler	67394	x	x	x	1						x	2

* Denotes new parts

/ Optional

Note 1 - Used on International Units Only

HOMELITE XL CHAIN SAWS

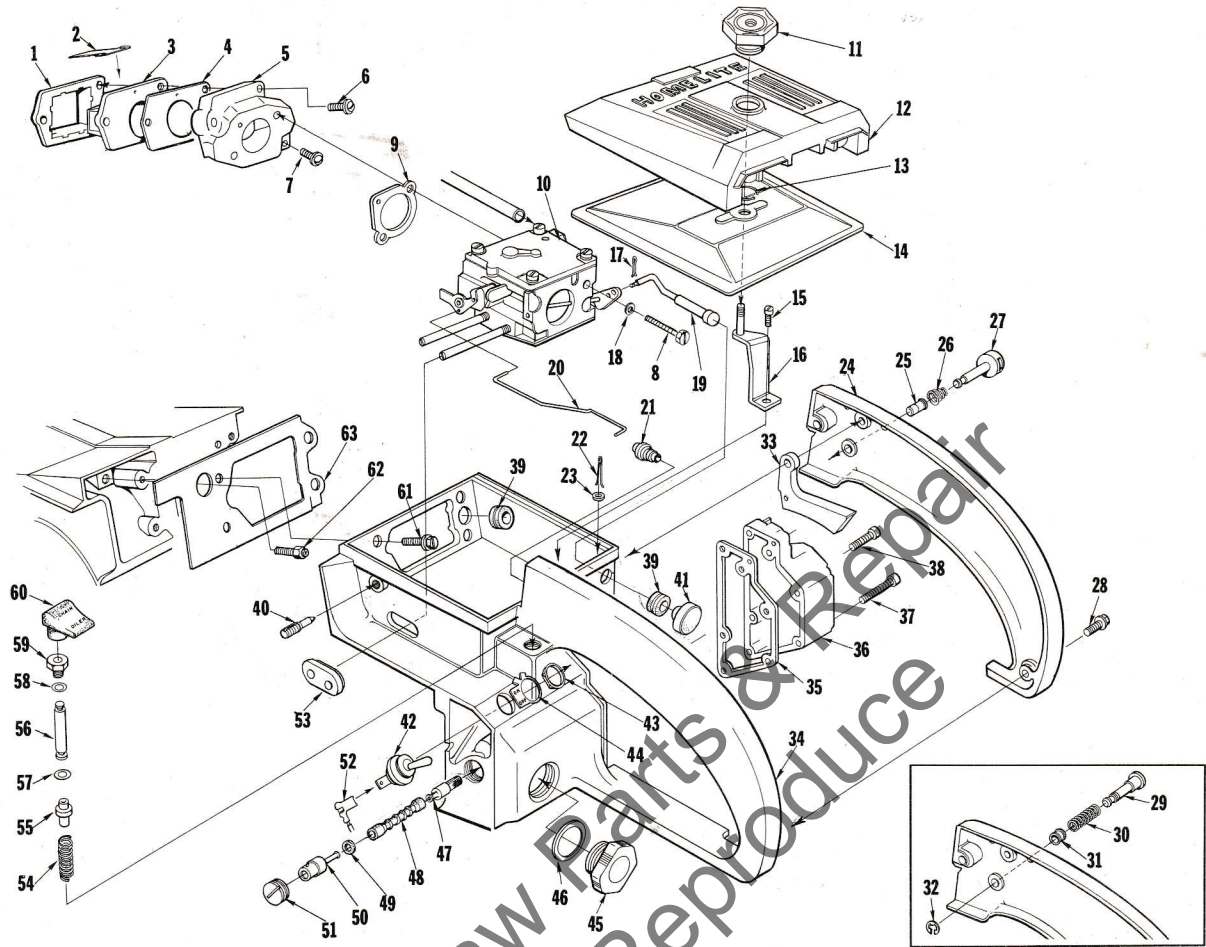

FIGURE 3

No.	Description	Part No.	XL-113	XL-114	XL-122	Qty.	No.	Description	Part No.	XL-113	XL-114	XL-122	Qty.
1	RETAINER-reed valve	64253	x	x	x	1	34	HANDLE-throttle	A-67697-A	x	x		1
2	REED-valve	50678-B	x	x	x	4		HANDLE-throttle	A-67698-A	x			1
3	SEAT-reed valve	64252	x	x	x	1		Includes: RIVET-accordion(not shown)	65889	x	x		2
4	GASKET-reed valve seat	64266	x	x	x	1	35	GASKET-oil tank	67265	x	x	x	1
*5	MANIFOLD-intake	A-67502-A	x	x	x	1	36	COVER-oil tank	67138-3	x	x	x	1
6	Includes: SCREW-pan, 8-32 x 1 1/4	82174	x	x	x	2	37	SCREW-fil, 8-32 x 1 5/8	82153	x	x	x	3
7	SCREW-pan, 8-32 x 1	82173	x	x	x	1	38	SCREW-fil, 8-32 x 3/4	82156	x	x	x	3
8	SCREW-hex, 10-32 x 1 7/8	82179	x	x	x	2	39	GROMMET	64862	x	x	x	2
9	GASKET-carburetor	67631	x	x	x	1	40	SCREW-idle adjustment	65522	x	x	x	1
10	CARBURETOR	A-67681	x	x	x	1	41	BUTTON-choke	57289-1	x	x	x	1
11	NUT-cover mounting	A-67627	x	x	x	1	42	SWITCH	A-63938	x	x	x	1
12	COVER-air filter	63183-2	x	x	x	1	43	Includes: NUT	72084-A1	x	x	x	1
13	RING-retaining	58319-A	x	x	x	1	44	PLATE-"On-Off"	63910	x	x	x	1
14	FILTER ELEMENT-air	A-63955-A	x	x	x	1	45	CAP-oil (vented)	A-65284	x	x	x	1
15	SCREW-hex, 12-24 x 1/2	80821	x	x	x	1	46	Includes: "O" RING	65133	x	x	x	1
16	BRACKET-air filter cover	A-63576	x	x	x	1		VALVE-vent (not shown)	63718	x	x	x	1
17	PIN-cotter	86324	x	x	x	1	47	FILTER-oil (manual)	A-64293	x	x	x	1
18	WASHER-lock, #10	83046	x	x	x	2	48	LINE-flexible oil	64356	x	x	x	1
19	ROD-choke	A-63942-1	x	x	x	1	49	GASKET	59736	x	x	x	1
20	ROD-throttle	63896-1	x	x	x	1	50	FITTING-check valve	A-63936	x	x	x	1
*21	BOOT-throttle rod	67634	x	x	x	1	51	SCREW-set	63113	x	x	x	1
22	PIN-cotter	86301	x	x	x	1	52	LEAD-ground	A-63939	x	x	x	1
23	WASHER-felt	63290	x	x	x	1	53	GROMMET-"Hi-Lo"	58858	x	x	x	1
24	COVER-throttle handle	63599-3	x	x	x	1	54	SPRING-plunger	65080	x	x	x	1
25	BUSHING-throttle lock	64646	x	x	x	1	55	PLUNGER-oil pump	65081	x	x	x	1
26	SPRING-throttle lock	64677	x	x	x	1	56	ROD-plunger	A-65199	x	x	x	1
27	PIN-throttle lock	65592	x	x	x	1	57	Includes: "O" RING	58406	x	x	x	1
28	SCREW-pan, 8-32 x 1/2	80560	x	x	x	2		"O" RING	59074	x	x	x	1
29	PIN-throttle lock	58924-1				1	59	NUT-plunger	65082	x	x	x	1
30	SPRING-throttle lock	58405				1	60	BUTTON-oil pump	67386	x	x	x	1
31	BUSHING-throttle lock	59064				1	61	SCREW-hex, 12-24 x 5/8	80676	x	x	x	4
32	RING-retaining	58409				1	62	VENT-fuel tank	A-65608	x	x	x	1
33	TRIGGER-throttle	63212-A	x	x	x	1	63	GASKET-throttle handle	64267	x	x	x	1

* Denotes new parts

ALWAYS FURNISH MODEL AND SERIAL NUMBER WHEN ORDERING PARTS.

HOMELITE XL CHAIN SAWS

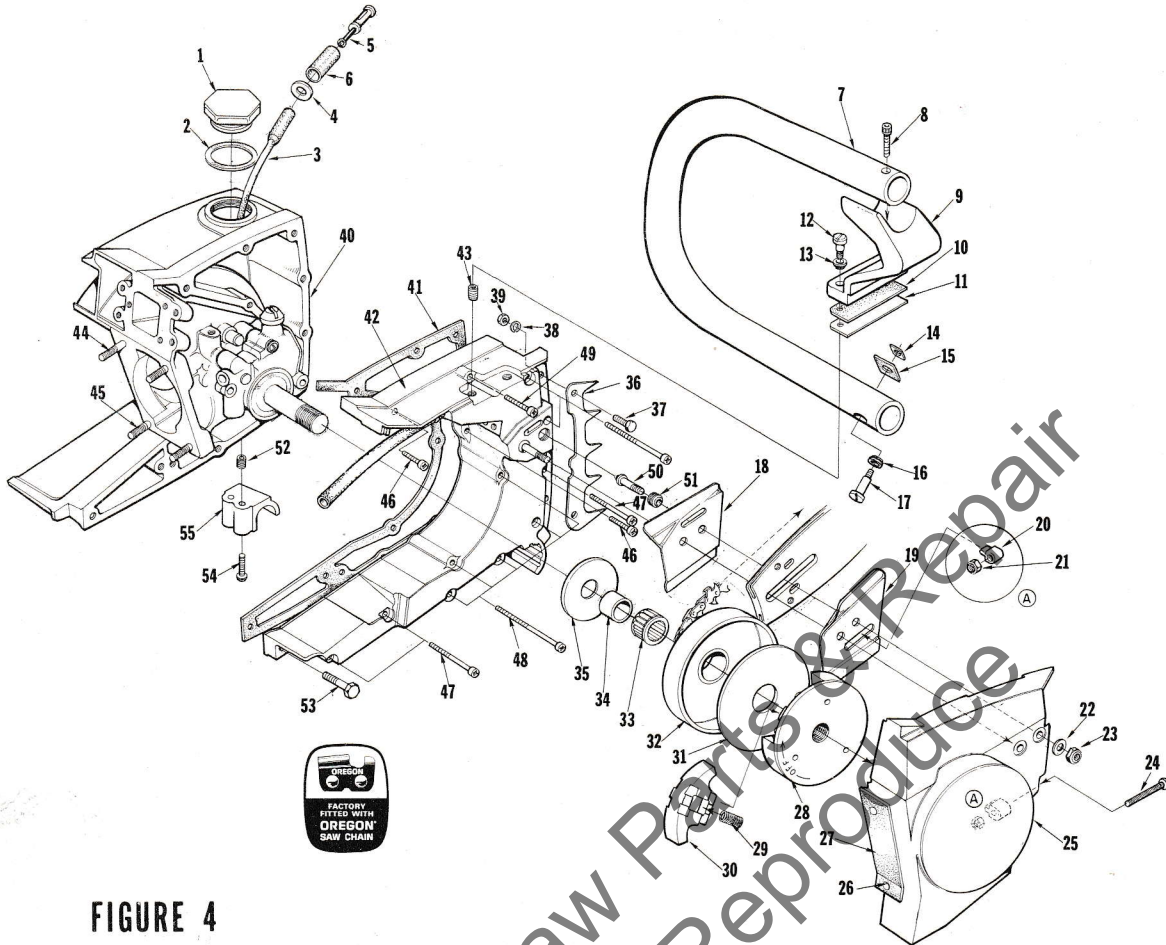

FIGURE 4

No.	Description	Part No.	XL-113	XL-114	XL-122	Qty.	No.	Description	Part No.	XL-113	XL-114	XL-122	Qty.
1	CAP-fuel filler	A-67501	x	x	x	1		SPROCKET & DRUM-See Note 1	A-64908	/	/	/	1
2	Includes: Gasket	53957	x	x	x	1		SPROCKET-3/8" pitch, 7 tooth	OM68210	x	x	x	1
3	LINE-fuel	63544	x	x	x	1	33	BEARING-cage	64124	x	x	x	1
4	WASHER	64182	x	x	x	1	34	RACE-inner	65985	x	x	x	1
5	FILTER-fuel	A-63920	x	x	x	1	35	WASHER-thrust (inner)	58833-1	x	x	x	1
6	Includes: FILTER-felt	64083	x	x	x	1	36	BUMPER-spiked	A-64722	/	/	/	1
7	HANDLE BAR	A-65567-1	x	x	x	1	37	Includes: Screw-hex, 12-24 x 5/8	80676	/	/	/	2
8	SCREW-soc., 10-32 x 1	82126	x	x	x	1	38	WASHER-lock #12	83056	/	/	/	2
9	BRACKET-handle bar	A-65666-1	x	x	x	1	39	NUT-hex, 12-24	81068	/	/	/	2
10	PAD-bracket	64610	x	x	x	1	40	CRANKCASE & TANK	A-64797-D	x	x	x	1
11	PLATE-handle bar bracket	65586	x	x	x	1		Includes: PIN-dowel (not shown)	71430	x	x	x	2
12	SCREW-shoulder	64614-A	x	x	x	2		PIN-dowel (not shown)	65365	x	x	x	2
13	GROMMET-handle bar	64474	x	x	x	2		SEAL(See Fig. 2, Index #28)	58308-A	x	x	x	1
14	PLATE-handle bar	65670	x	x	x	1	41	GASKET-fuel tank	65364	x	x	x	1
15	PAD-handle bar	65559	x	x	x	1	42	COVER-fuel tank	A-65576-A	x	x	x	1
16	GROMMET-handle bar	67066	x	x	x	1		Includes: (not shown)					
17	SCREW-shoulder	64754	x	x	x	1		GASKET-check valve	58338	x	x	x	1
18	PLATE-guide bar (inner)	63638-B	x	x	x	1		CAP-check valve	58339	x	x	x	1
19	PLATE-guide bar (outer)	63639-A	x	x	x	1	43	INSERT-taplock	72489	x	x	x	3
20	PIN-bar adjusting	65768-1	x	x	x	1	44	STUD-cylinder (long)	63868	x	x	x	1
21	NUT-lock, 10-32	81211	x	x	x	1	45	STUD-cylinder (short)	55871	x	x	x	3
22	WASHER-flat, 5/16	84032	x	x	x	2	46	SCREW-fil, 8-32 x 15/16	82151	x	x	x	2
23	NUT-hex, 5/16-18	81196	x	x	x	2	47	SCREW-fil, 8-32 x 1 7/8	82154	x	x	x	3
24	SCREW-guide bar adjusting	65944	x	x	x	1	48	SCREW-fil, 8-32 x 2 3/16	82155	x	x	x	7
25	COVER-drivecase	A-64620-1	x	x	x	1	49	SCREW-fil, 8-32 x 1 1/4	82152	x	x	x	1
26	Includes: RIVET-oval head	85061	x	x	x	2	50	STUD-guide bar	63861	x	x	x	2
27	SHIELD-sawdust	64618	x	x	x	1	51	INSERT-threaded	59896-A	x	x	x	2
28	PLATE-clutch	64904-1	x	x	x	1	52	INSERT-taplock	72489	x	x	x	2
29	SPRING-clutch	65842	x	x	x	3	53	SCREW-hex, 12-24 x 7/8	80891	x	x	x	1
30	SHOE-clutch	64569-3	x	x	x	3	*	KIT-handle bar stop	A-67706	x	x	x	
31	COVER-clutch	63671	x	x	x	1	54	Includes: SCREW-pan, 10-32 x 5/8	80572	x	x	x	
32	DRUM & HUB	A-65988	x	x	x	1	55	STOP-handle bar	67506-2	x	x	x	

*Denotes new parts

/ Optional

NOTE 1 - Units using A-64908 must use 63860 Thrust Washer, 63990 Inner Race, 64333 Needle Bearing.

HOMELITE XL CHAIN SAWS

SPECIAL TOOLS (available on order)

A-23937-B	WRENCH-combination
22820-5	COLLAR-bearing installation (bearing to shaft)
22828	PLIERS-retaining ring
23136-1	SLEEVE-bearing and shaft installation
23528	WRENCH-socket screw (connecting rod)
23756	PLUG-needle bearing (connecting rod)
23759	SLEEVE-seal protection (back plate)
23846-2	ANVIL-roller bearing disassembly
A-23934	SPANNER-clutch
A-23949	TOOL-piston pin removal
A-23960	BRACKET-rotor removal
23972	SLEEVE-seal installation
24006-2	PLATE-shaft alignment
A-24051	JACKSCREW (bearing to shaft to crankcase)
24054-	PLUG-seal assembly (crankcase)
24055	PLUG-bearing and seal assembly (back plate)
A-24057	BEARING REMOVER-(back plate)
24076	SLEEVE-seal protecting (crankcase side)
A-24138	REAMER-compression release
24230	DRIVER-hand, pozidriv
24173	DRIVER-check valve installation
A-23841-A	WRENCH-insert
24304	BIT-pozidriv #2

Accessories

*A-68074	SPARK ARRESTER-(Reed Muffler)
65543-1	HEAT EXCHANGER
A-64818	SPARK ARRESTER-Note 1

Paint

24101	SPRAY CAN-dark blue
23475	SPRAY CAN-red

*Denotes new parts

NOTE 1 - Used on International Units only

HOMELITE XL CHAIN SAWS

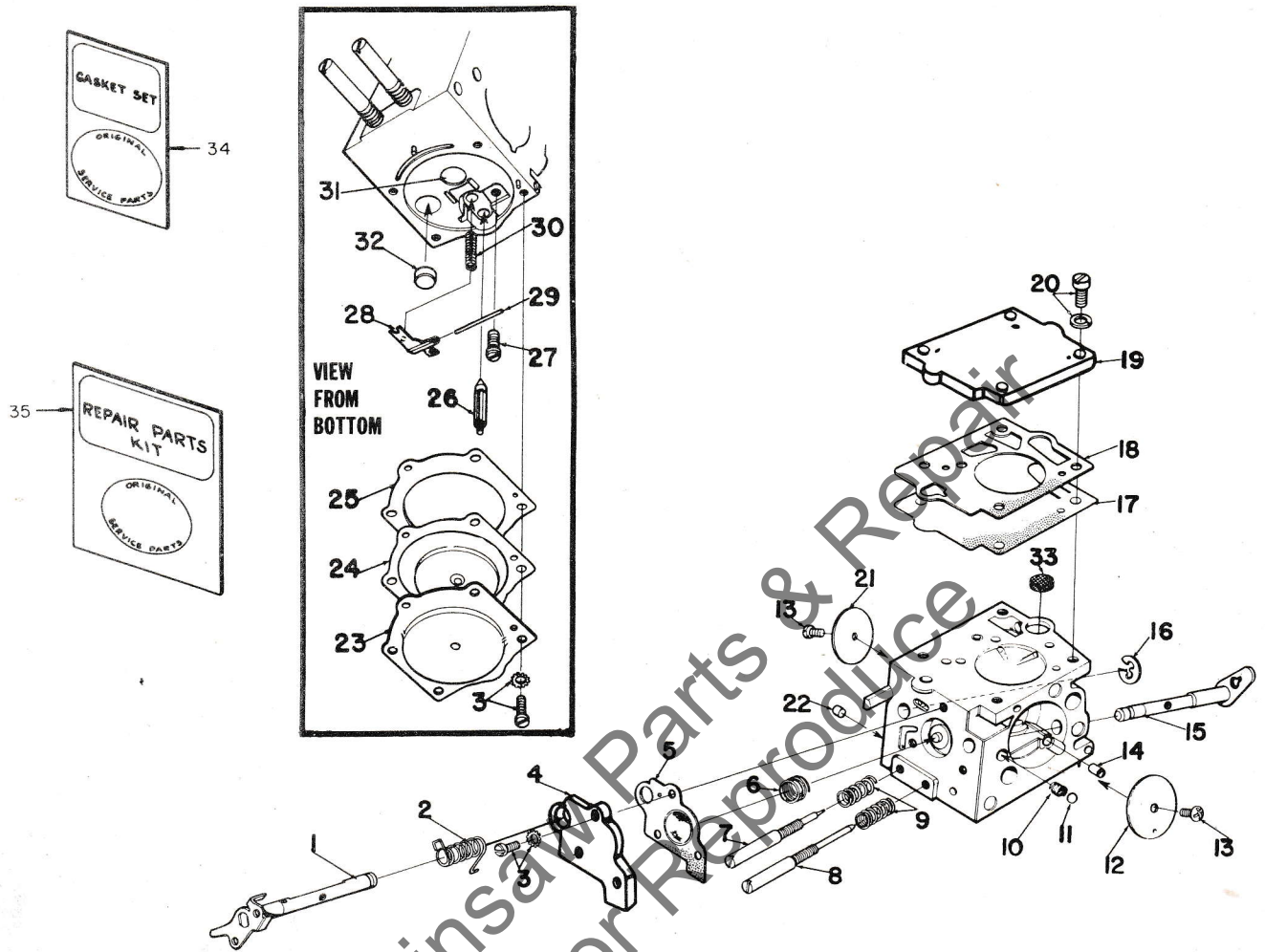

No.	Description	Part No.	Qty.
1	THROTTLE SHAFT ASSEMBLY	64225	1
2	SPRING-throttle return	64239	1
3	SCREW ASSEMBLY	64689	7
4	COVER-accelerator	67187	1
5	DIAPHRAGM-accelerator pump	67188	1
6	SPRING-accelerator pump	64240	1
7	NEEDLE-idle	64241	1
8	NEEDLE-high speed	64242	1
9	SPRING-needle adjusting	64236	2
10	SPRING-choke friction	64238	1
11	BALL-choke friction	60051	1
12	VALVE-choke	64228	1
13	SCREW-valve	64693	2
14	JET-idle air	64690	1
15	CHOKE SHAFT ASSEMBLY	64227	1
16	RING-throttle shaft retaining	64221	1
17	DIAPHRAGM-fuel pump	64233	1
18	GASKET-fuel pump	67008	1

No.	Description	Part No.	Qty.
19	COVER-fuel pump	67002	1
20	SCREW-fuel pump cover	64694	4
*21	VALVE-throttle	67700	1
22	PLUG-limiting	64692	1
23	COVER	64224	1
24	METERING DIAPHRAGM ASSEMBLY	64235	1
25	GASKET-metering diaphragm	64231	1
26	VALVE-inlet needle	64229	1
27	SCREW-metering lever pin	64688	1
28	LEVER-metering	64245	1
29	PIN-metering lever	64244	1
30	SPRING-metering lever	64237	1
31	PLUG-welch (main)	65482	1
32	PLUG-welch (idle)	30818	1
33	SCREEN-fuel inlet	64243	1
34	GASKET SET	67019	1
35	REPAIR KIT	67197	1
	REPAIR KIT-check valve	65386	1

∕Included in Repair Kit 67197
 *Denotes new parts.

HOMELITE XL CHAIN SAWS

Part No.	Description	Qty.	Part No.	Description	Qty.	Part No.	Description	Qty.	Part No.	Description	Qty.
22820-5	Collar	1	63718	Valve	2	A-64620-1	Cover	1	67285	Clamp	1
22828	Pliers	1	63861	Stud	2	64646	Bushing	1	A-67287	Plate	1
23136-1	Sleeve	1	63865-S	Bearing	1	64653	Spring	1	67340	Piston Ring	1
23475	Paint-red	1	63868	Stud (long)	1	64654	Lever	1	67386	Button	1
23528	Wrench	1	63869	Rope	1	64655-2	Clamp	1	*67394	Reed-muf.	1
23756	Plug	1	63870	Spring	1	A-64656-2	Pivot Pin	1	67395	Bearing	1
23759	Sleeve	1	63875	Ring	1	64677	Spring	1	67408	Bearing	1
A-23841-A	Wrench	1	63877	Stud	2	64688	Screw	1	A-67411	Rod	1
23846-2	Anvil	1	63896-1	Rod	1	64689	Screw	7	*67413-1	Stop	1
A-23934	Wrench	1	63905	Washer	2	64690	Jet	1	A-67437	Bearing	1
A-23937-B	Wrench	1	A-63919	Line	1	64692	Plug	1	*A-67446-1A	Body-muf.	1
A-23949	Plug	1	A-63920	Filter	1	64693	Screw	2	*67450	Baffle	1
A-23960	Puller	1	A-63936	Fitting	1	64694	Screw	4	A-67482	Valve	1
23972	Sleeve	1	63910	Plate	1	A-64722	Kit-bumper	1	67483	Lead-transf.	1
24006-2	Plate	1	A-63928	Cover	1	A-64741	Filter	1	67484	Lead-tension	1
A-24051	Jackscrew	1	A-63938	Switch	1	64754	Screw	1	A-67501	Cap	1
24054	Plug	1	A-63939	Lead	1	A-64797-D	Crankcase	1	*A-67502-A	Manifold	1
24055	Plug	1	A-63942-1	Rod	1	64813	Ring	1	67506-2	Stop	1
A-24057	Plug	1	A-63947	Line	1	A-64818	Arrestor	1	*A-67527-1	Cap	1
24076	Sleeve	1	A-63952-A	Pulley	1	64862	Grommet	2	A-67627	Nut	1
24101	Paint-blue	1	A-63955-A	Filter	1	64904-1	Plate	1	67631	Gasket	1
A-24138	Reamer	1	63990	Race	1	A-64908	Sprocket	1	*67634	Boot	1
24173	Driver	1	64021	Screw	2	64948	Lock	1	A-67681	Carburetor	1
24230	Driver	1	64083-1	Element	1	65080	Spring	1	A-67696	Piston & Pin	1
24304	Bit	1	64085	Screw	2	65081	Plunger	1	A-67697	Handle	1
25038	Gasket	1	64086	Condenser	1	65082	Nut	1	A-67698	Handle	1
28008	Clip	1	A-64087	Points	1	65133	"O" Ring	1	67700	Valve	1
28028	Washer	1	64088	Block	1	A-65199	Rod	1	A-67706	Kit-stop	1
30818	Plug	1	64089	Felt	1	A-65284	Cap	1	*A-67888-A	Muffler	1
31734	Connector	1	64090	Screw	2	65321	Screw	3	*A-68074	Spark Arrestor	1
A-33055	Terminal	1	64091	Coil	1	65364	Gasket	1	OM68210	Sprocket	1
54422	Core	1	64102-A	Screw	1	65365	Pin	2	71430	Pin	2
54423	Clip	1	64124	Bearing	1	65386	Repair Kit	1	72489	Insert	3
55411	Screw	2	64125	Cap	1	65482	Plug	1	75078	Key	1
55871	Stud	3	64126	Baffle	1	65491	Screen	1	75120	Ring	1
57289-1	Button	1	A-64130	Body	1	65522	Screw	1	76421	Screw	2
58308-A	Seal	1	64133-A	Screw	5	65543-1	Exchanger	1	FASTENING PARTS		
58319-A	Ring	2	64154	Insert	1	A-65557-1	Handle Bar	1	80183	8-32 x 7/8	2
58338	Gasket	1	64155	Grip	1	65559	Pad	1	80560	8-32 x 1/2	2
58339	Cap	1	64182	Washer	1	A-65576-A	Cover	1	80571	6-32 x 3/8	2
58405	Spring	1	64221	Ring	1	65586	Plate	1	80572	10-32x5/8	2
58406	"O" Ring	2	64224	Cover	1	65592	Pin	1	80575	8-32 x 1/4	2
58409	Ring	1	64225	Throttle	1	A-65608	Vent	1	80605	6-32 x 5/16	1
58688-A	Seal	1	64227	Choke	1	A-65666-1	Bracket	1	80648	10-32 x 1/2	1
58758-2	Spring	2	64228	Valve	1	65670	Plate	1	80676	12-24 x 5/8	2
58833-1	Washer	1	64229	Valve	1	65696	Fitting	1	80821	12-24 x 1/2	1
58851	Washer	2	64231	Gasket	1	65768-1	Pin	1	80889	8-36 x 1/2	2
58858	Grommet	1	64233	Diaphragm	1	65829	Gasket	1	80891	12-24 x 7/8	1
58924-1	Pin	1	64235	Metering	1	65842	Spring	3	80919	4-40 x 1/4	2
58957	Gasket	1	64236	Spring	2	65889	Rivet	2	80983	8-32 x 1/2	4
58966	Lead	1	64237	Spring	1	65944	Screw	1	81065-2	Nut-1/4-28	4
59064	Bushing	1	64238	Spring	1	A-65948	Valve	1	81068	Nut-12-24	2
59074	"O" Ring	1	64239	Spring	1	65949-2	Clamp	1	81112	Nut-5/16-24	1
59678-B	Reed	4	64240	Spring	1	65985	Race-inner	1	81126	Nut-6-32	2
59704	Screw	2	64241	Needle	1	A-65988	Drum & Hub	1	81196	Nut-5/16-18	2
59736	Gasket	2	64242	Needle	1	67002	Cover	1	81211	Nut-10-32	1
59896-A	Insert	2	64243	Screen	1	67008	Gasket	1	82126	10-32 x 1	1
60051	Ball	1	64244	Pin	1	67019	Gasket	1	82151	8-32 x 15/16	2
63113	Screw	1	64245	Lever	1	A-67023	Housing	1	82152	8-32 x 1 1/4	1
63183-2	Cover	1	64252	Seat	1	67066	Grommet	1	82153	8-32 x 1 5/8	3
63204-1	Crankshaft	1	64253	Retainer	1	A-67079	Line	1	82154	8-32 x 1 7/8	3
63212-A	Trigger	1	64266	Gasket	1	67138-3	Cover	1	82155	8-32 x 2 3/16	7
63228	Worm	1	64267	Gasket	1	67177	Bushing	1	82156	8-32 x 3/4	3
63290	Washer	1	A-64293	Filter	1	67185	Washer	1	82173	8-32 x 1	1
63361-A	Gasket	1	64301	Retainer	1	67187	Cover	1	82174	8-32 x 1 1/4	2
63544	Line	1	64333	Bearing	1	67188	Diaphragm	1	82177	8-32 x 5/8	2
63547-S	Plug	1	64356	Line	1	A-67189-1	Cylinder	1	82178	8-32 x 3/4	2
A-63576	Bracket	1	64374	Bushing	1	67191	Stud	4	82179	10-32 x 1 7/8	2
63599-3	Cover	1	64393	Seal	1	A-67192-A	Housing	1	83009	Washer-1/4	4
63606	Washer	1	64405-1	Cylinder	1	67197	Repair Kit	1	83046	Washer-#10	2
63624-1B	Plate	1	64423	Cap	1	67222	Ring	1	83056	Washer-#12	2
63637	Rotor	1	64442	Pawl	2	67265	Gasket	1	83106	Washer-#8	4
63638-B	Plate(inner)	1	64474	Grommet	2	67275	Transformer	1	83860	Washer	1
63639-A	Plate(outer)	1	A-64542-2A	Cylinder	1	67277	Core	1	84018	Washer-#6	2
63671	Cover	1	64569-3	Shoe	3	67280	Lead	1	84032	Washer-5/16	2
63713	Shield(inner)	1	64610	Pad	1	67281	Condenser	1	84065-1	Washer-5/16	1
63714	Shield(outer)	1	64614-A	Screw	2	67283	Module	1	86301	Pin-cotter	1
						67284	Rotor	1	86324	Pin-cotter	1

*Denotes new parts

ALWAYS FURNISH MODEL AND SERIAL NUMBER WHEN ORDERING PARTS.

Leon's Chainsaw Parts & Repair
Do Not Sell or Reproduce

HOMELITE®

A **textron** DIVISION

PORT CHESTER, N.Y., U.S.A.

