

HOMELITE[®]
JACOBSEN

REV. 4
PART NO. 24228
Printed in U.S.A.
Price .35

PARTS LIST

HOMELITE[®]

XL-12

WITH PYRAMID REED SYSTEM

AND

SXL-AO

CHAIN SAWS

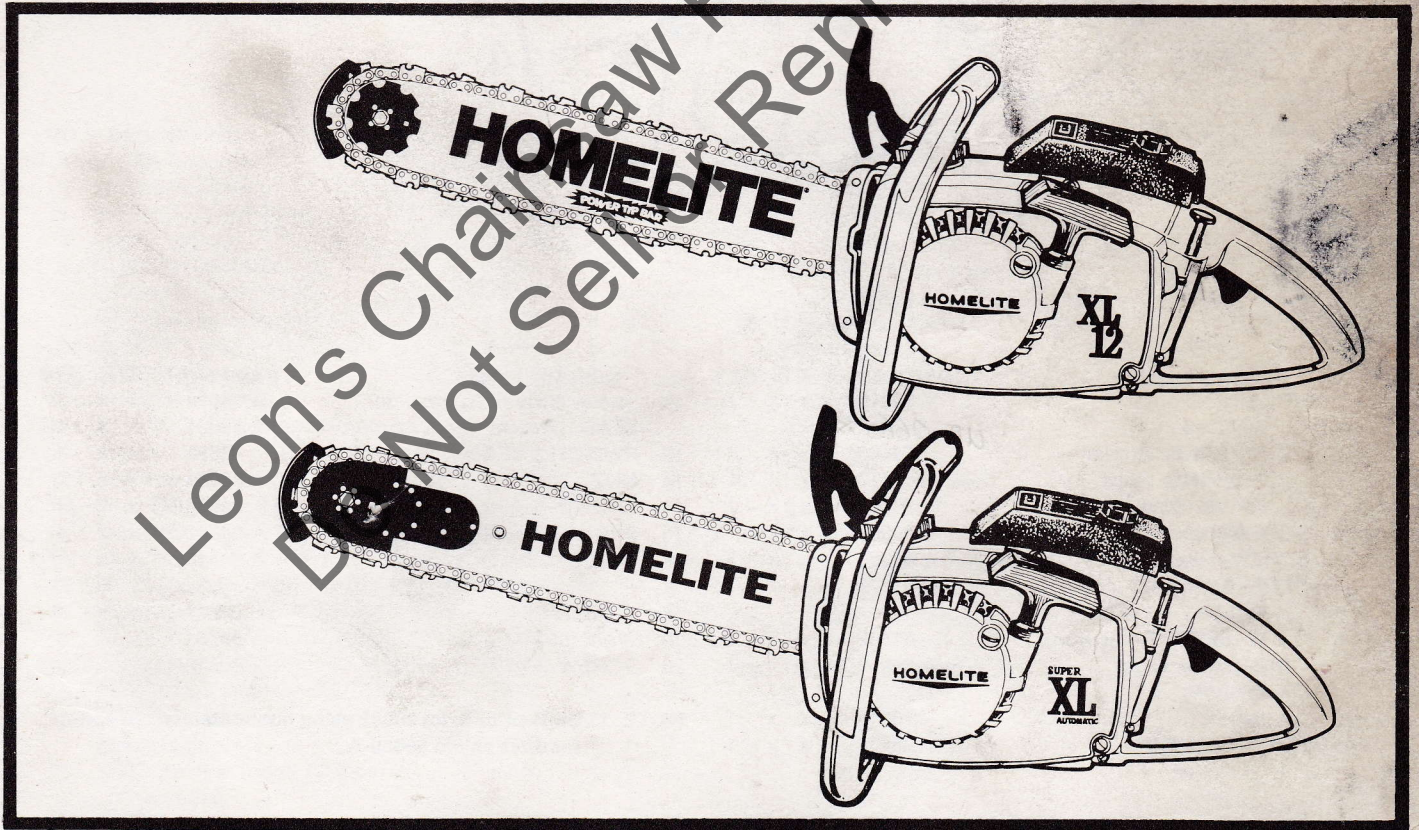

HOMELITE **TEXTRON**

Homelite Division of Textron Inc.

XL-12/SXL-AO

FIGURE 1

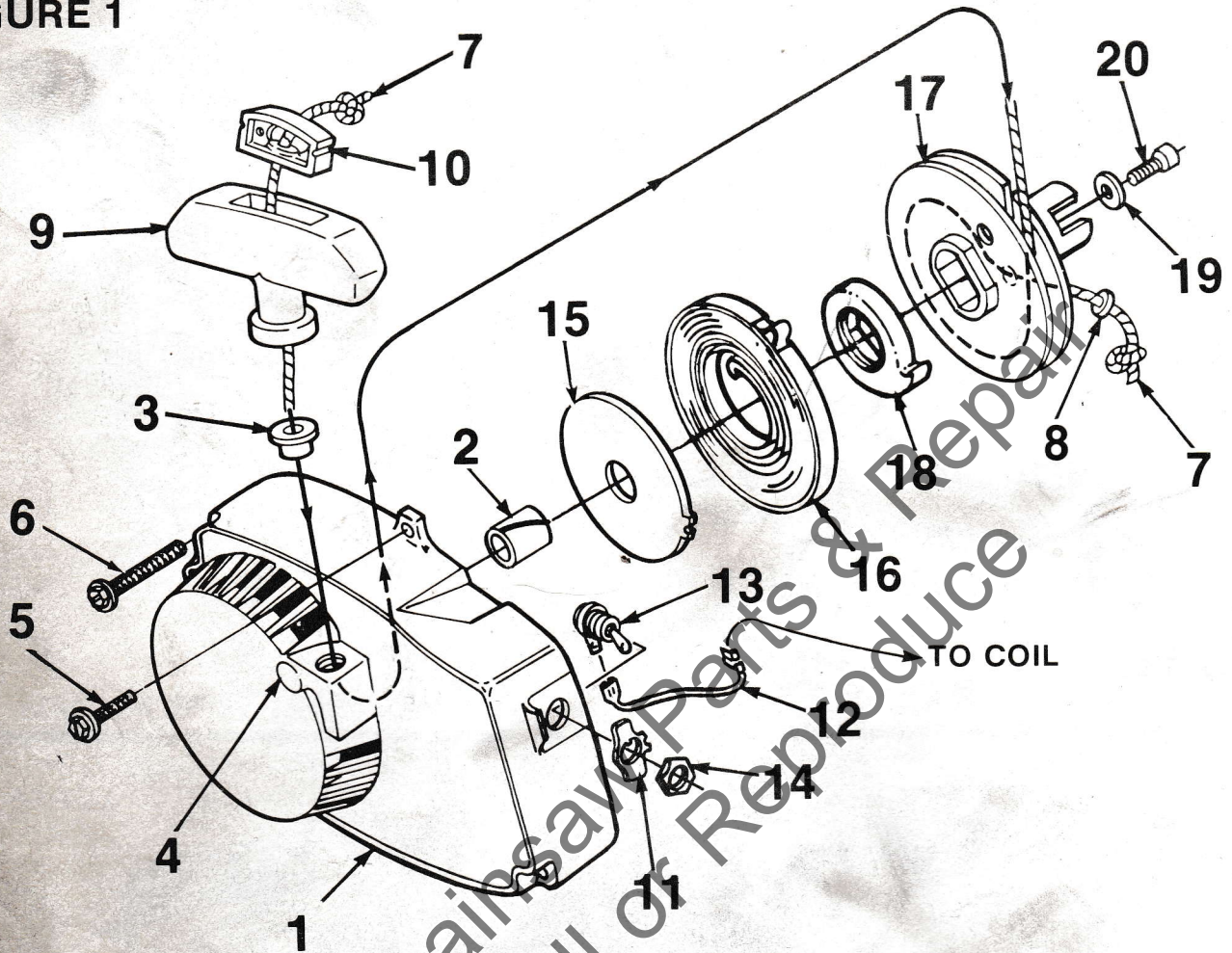

NO.	DESCRIPTION	PART NO.	XL-12	SXL-AO	QTY
1	HOUSING- Fan Includes:	A-64518	x	x	1
2	BUSHING- Starter	64443	x	x	1
3	BUSHING- Rope	67177	x	x	1
4	DRIVE- Stud	59067	x	x	1
5	SCREW- Hex 12-24 x 9/16	80899	x	x	1
6	SCREW- Hex 12-24 x 1 1/16	58963	x	x	3
7	ROPE- Starter 48" long #5 Includes:	A-93875	x	x	1
8	WASHER- Flat (nylon)	93862	x	x	1
9	GRIP- Starter rope Includes:	A-69962-B	x	x	1
10	INSERT	70018-A	x	x	1
11	PLATE- "On-Off"	95231	x	x	1

NO.	DESCRIPTION	PART NO.	XL-12	SXL-AO	QTY.
12	LEAD- Ground (solid state)	A-94850	x	x	1
	LEAD- Ground (point ignition)	A-59031	x	x	1
13	SWITCH & LEAD	96831	x	x	1
14	NUT	72084-A1	x	x	1
15	SHIELD- Spring (inner)	59638-B	x	x	1
16	SPRING- Recoil (Note 1)	A-94842	x	x	1
17	PULLEY- Starter Includes:	A-64446	x	x	1
	BUSHING- Spring	94827	x	x	1
19	WASHER- Retainer	58763	x	x	1
20	SCREW- Hex 10-32 x 1/2	80648	x	x	1

NOTE 1: Units prior to lot #0092 using noncontainerized spring requires shield 59639-A.

ALWAYS FURNISH MODEL AND SERIAL NUMBERS WHEN ORDERING PARTS.

FIGURE 2

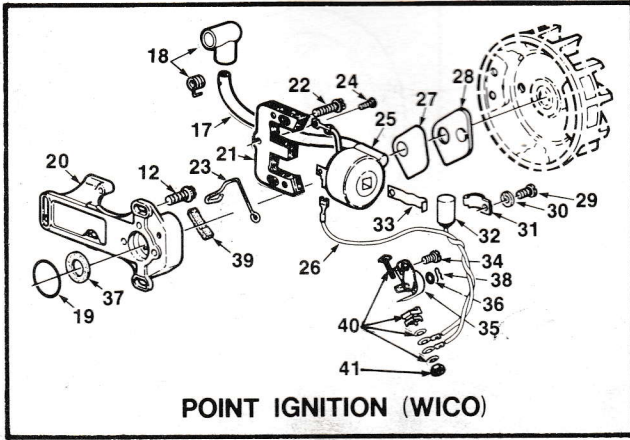

*all points
0.015*

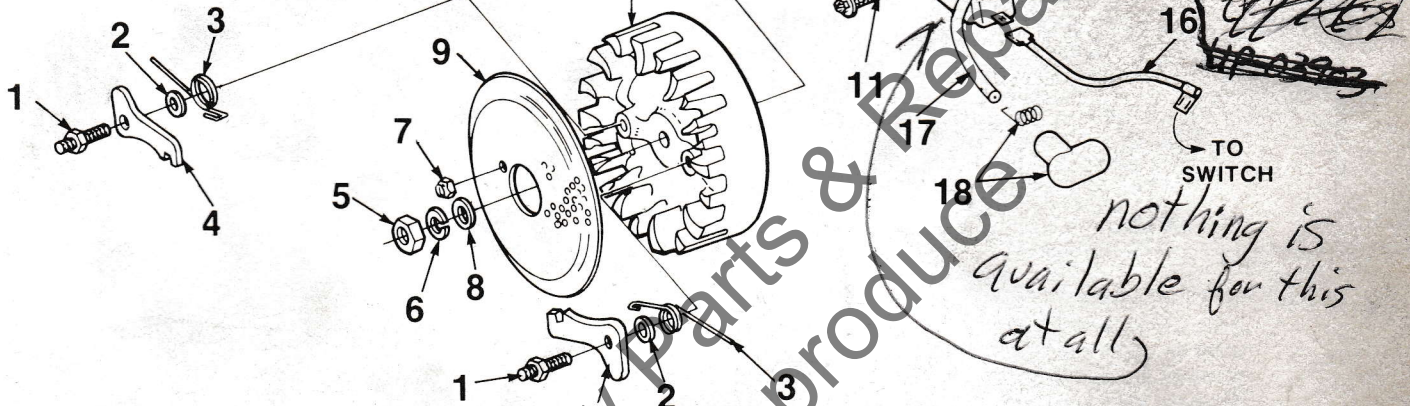

NO.	DESCRIPTION	PART NO.	XL-12	SXL-AO	QTY.	NO.	DESCRIPTION	PART NO.	XL-12	SXL-AO	QTY.
1	STUD- Shoulder	58757-E	x	x	2	25	COIL- with lead (point ignition)	A-94325	x	x	1
2	WASHER- Lock	70901	x	x	2		Includes:				
3	SPRING- Starter pawl	65375-2	x	x	2	26	LEAD	93095	x	x	1
4	PAWL- Starter	58756	x	x	2	27	GASKET- Breaker box cover (point ignition)	58810	x	x	1
5	NUT- Hex (5/16-24)	81117	x	x	1	28	COVER- Breaker box (point ignition)	58811	x	x	1
6	WASHER- Lock (5/16)	83002	x	x	1	29	SCREW- Hd. (8-32 x 5/16) (point ignition)	30261	x	x	1
7	NUT- Center lock (#10-32)	81206	x	x	2	30	WASHER- Lock (point ignition)	83060	x	x	2
8	WASHER- Flat (5/16)	84056	x	x	1	31	CLAMP- Condenser (point ignition)	59622	x	x	1
9	SCREEN- Starter	58765	x	x	1	32	CONDENSER (point ignition)	63250-A	x	x	1
10	ROTOR- Magneto	70639	x	x	1	33	CLIP- Coil retaining (point ignition)	63726	x	x	1
11	SCREW- Hex washer hd. (8-32 x 3/4)	82248	x	x	2	34	SCREW- Contact plate (point ignition)	76421	x	x	1
12	SCREW- Hex hd. (12-24 x 9/16)	80899	x	x	3	35	POINTS- Breaker (point ignition)	A-58914-A	x	x	1
13	PLATE- Ignition coil mtg. (Solid state)	A-94326-1	x	x	1		Includes:				
14	KEY- Rotor (woodruff)	75078	x	x	1	36	WASHER- Plain	28028	x	x	A/R
15	MODULE & CORE (Solid state)	A-94605-S	x	x	1	37	SEAL- Felt	59760	x	x	1
16	LEAD- Ground (Solid state)	A-94850	x	x	1	38	CLIP	28008	x	x	1
17	LEAD- Ground (Point ignition)	A-59031	x	x	1	39	CAM- Felt		x	x	1
18	LEAD- High tension	58966	x	x	1	40	BLOCK- Terminal (point ignition)	A-68162	x	x	1
19	TERMINAL- High tension	A-33055	x	x	1		Includes:				
20	GASKET- Stator (point ignition)	59538	x	x	1	41	NUT- Connection stud	93099	x	x	1
21	BOX- Breaker (point ignition)	A-94556	x	x	1						
	Includes:										
22	CORE	93098	x	x	1						
23	SCREW- Hex washer hd. (8-32 x 3/4)	82248	x	x	2						
24	CLIP- Breaker box cover (point ignition)	76413	x	x	1						
25	SCREW- Terminal (point ignition)	64090	x	x	1						

ALWAYS FURNISH MODEL AND SERIAL NUMBERS WHEN ORDERING PARTS.

XL-12/SXL-AO

FIGURE 3

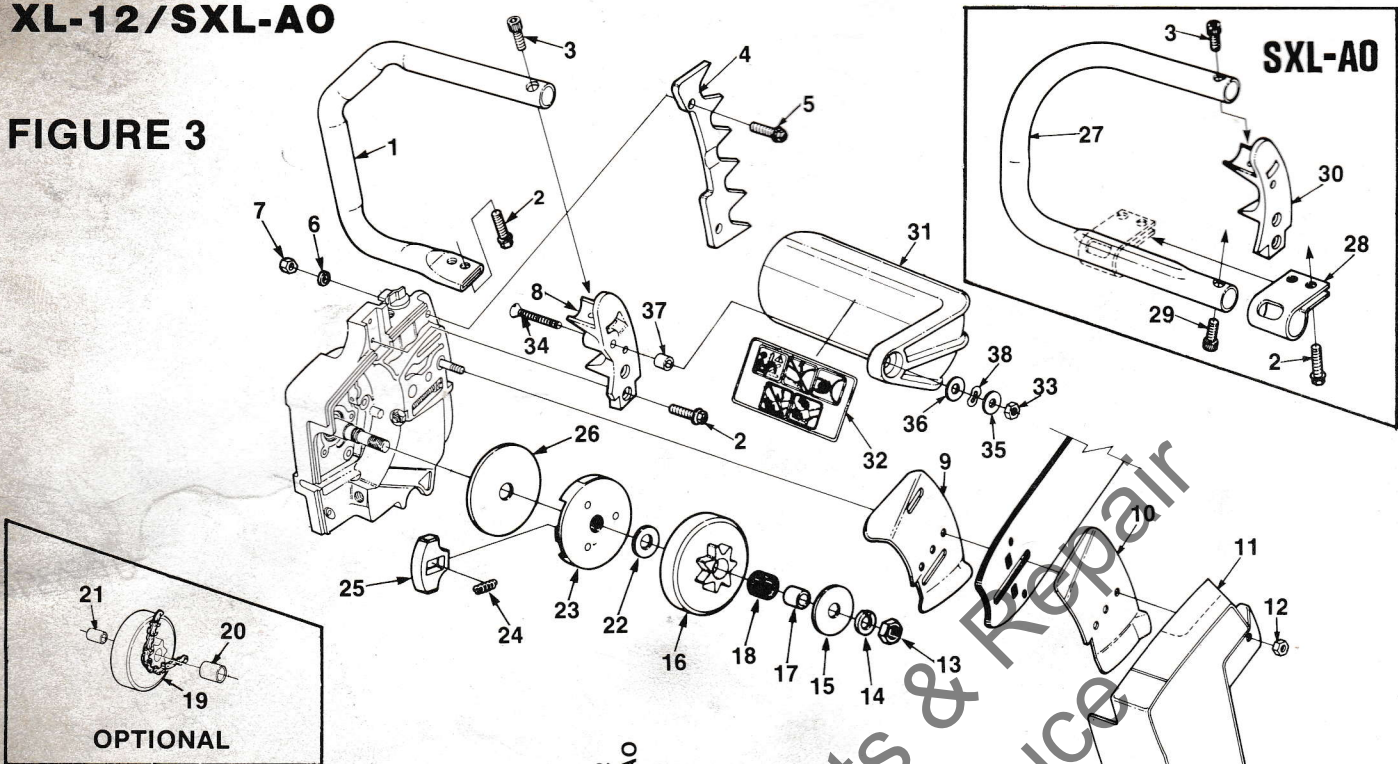

NO.	DESCRIPTION	PART NO.	XL-12	SXL-AO	QTY.
1	HANDLE BAR- Flush cut	A-58793-B	x		1
2	SCREW- 12-24 x 3/4	80867	x	x	4
3	SCREW- Socket hd. 1/4-20 x 1	80428-1	x	x	1
4	BUMPER KIT- Spiked (Accessory)	DA-59043	x	x	1
Includes:					
5	SCREW- Hex 12-24 x 3/4	80867	x	x	2
6	WASHER- Lock #12	70901	x	x	2
7	NUT- Hex 12-24	81068	x	x	2
8	BRACKET- Handle bar	59246-7	x		1
8	KIT- Guide bar plate	A-70618	x	x	1
Includes:					
9	PLATE- Guide bar (inner)	70399	x	x	1
10	PLATE- Guide bar (outer)	70400	x	x	1
11	COVER- Drivecase	58750-16	x		1
12	NUT- Hex 3/8-16	81089-2	x	x	2
13	NUT- Lock 3/8-24	81124	x	x	1
14	WASHER- Lock 3/8	83018	x	x	1
15	WASHER- Thrust (outer)	65064	x	x	1
16	SPROCKET & DRUM 7 tooth (std.)	A-95459	x	x	1
(Note 2) 3/8, 7 tooth					
17	RACE- Inner	65746-B	x	x	1
18	BEARING- Roller	64124	x	x	1
19	SPROCKET & DRUM (opt.) 3/8" pitch, 8 T	A-63346	x	x	1
.404 pitch, 7 T					
Includes:					
20	BEARING- Needle (Note 3)	72311	x	x	1
21	RACE- Inner (Note 3)	55584	x	x	1
HUB & DRUM- "splined" (opt.) (used with index #17, 18, 22 and rim sprockets)					
SPROCKET- Splined rim typed 3/8" 7 T (Note 2)					
.404 pitch, 7 tooth (note 2)					
22	WASHER- Thrust (inner)	58833	x	x	1
CLUTCH & COVER					
Includes:					
23	PLATE- Clutch	65760-1B	x	x	1

NO.	DESCRIPTION	PART NO.	XL-12	SXL-AO	QTY.
24	SPRING- Clutch	67053	x	x	3
25	SHOE- Clutch	69461	x	x	3
26	COVER- Clutch	95054	x	x	1
27	HANDLE BAR- Flush cut	A-70365		x	1
Includes:					
28	CLAMP	63291-A	x		1
29	SCREW- Soc. hd. 1/4-20	80428-1	x		1
30	BRACKET- Handle bar (Note 1)	59651-12	x		1
ACCESSORIES NOT SHOWN					
HANDLE BAR- Wrap around (Accessory) (Note 1)					
Includes:					
HANDLE BAR					
A-63421					
x 1					
BRACKET- Handle bar					
59651-6B					
x 1					
BRACKET- Handle bar mtg.					
63405					
x 1					
SCREW- Hex hd. 12-24 x 5/8					
80676					
x 1					
31	GUARD- Hand	A-95088	x	x	1
Includes:					
32	DECAL	96990	x	x	1
33	NUT- 12/24	81225	x	x	1
34	SCREW- (12-24 x 1 1/4)	82223	x	x	4
35	WASHER (5/16)	95935	x	x	1
36	WASHER	84065	x	x	1
37	SPACER	95937	x	x	1
38	WASHER- Spring wave	96757	x	x	1

NOTE 1: A-63421 Handle bar requires 59651-6B bracket to replace index #30, and another 63405 bracket which mounts on drivecase cover. 80676 screw attaches drivecase cover bracket to handle bar.

NOTE 2: Check type and number of teeth before ordering. "Splined" hub and drum requires one of the "Splined" Sprockets listed.

NOTE 3: Race 55584 required with #72311 needle bearing.

ALWAYS FURNISH MODEL AND SERIAL NUMBERS WHEN ORDERING PARTS.

FIGURE 4

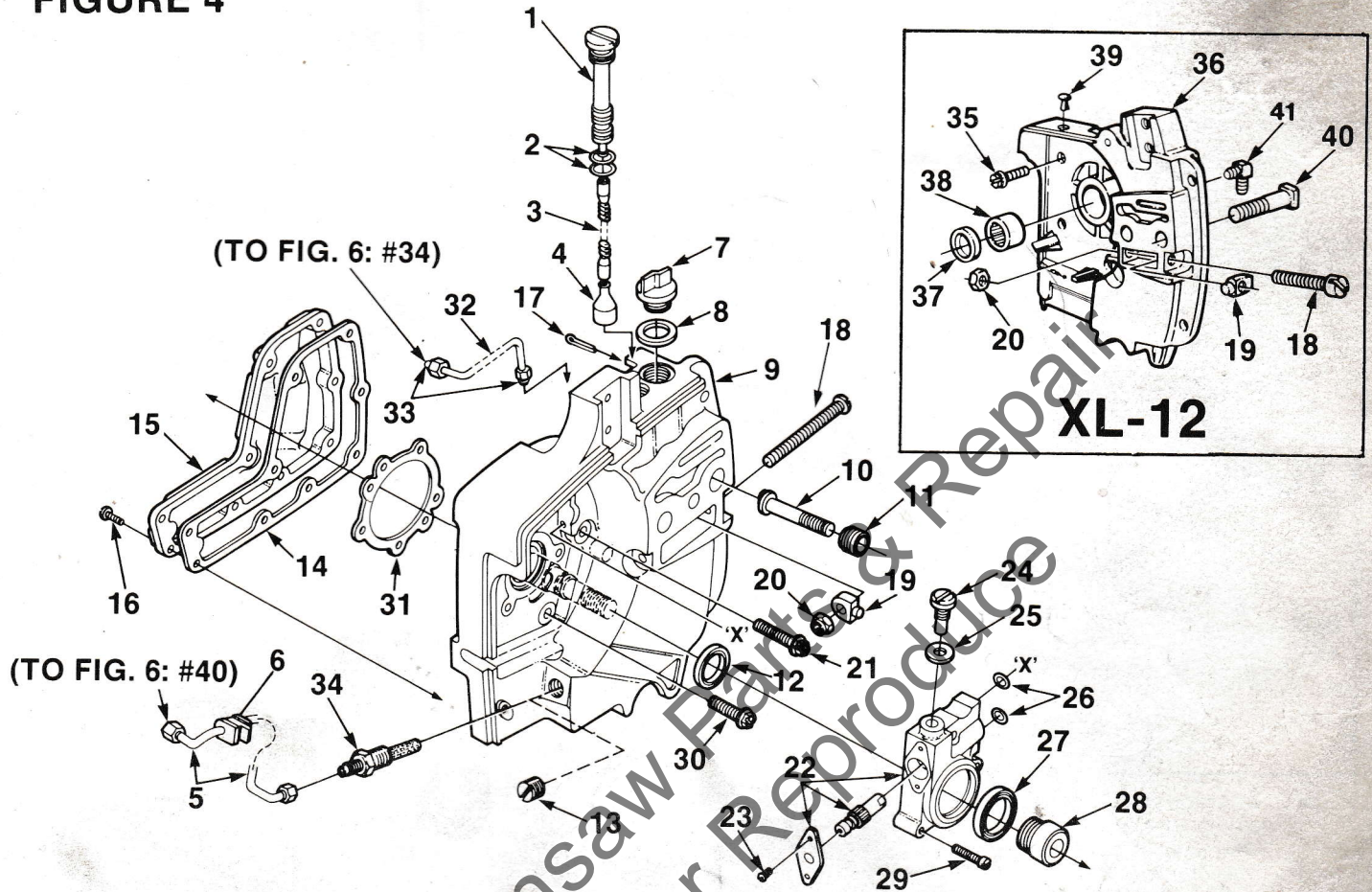

NO.	DESCRIPTION	PART NO.	XL-12	SXL-AO	QTY.	NO.	DESCRIPTION	PART NO.	XL-12	SXL-AO	QTY.
	OIL FILTER ASSEMBLY	A-69371	x		1	21	SCREW- Hex 12-24 x 1	80864	x		1
	Includes:					22	PUMP- Automatic oil	A-59809-B	x		1
1	TUBE- Oil line	59325-2	x		1		Includes:				
2	"O" RING	59765	x		2	23	SCREW- Pan 4-40 x 1/4	80919	x		2
3	TUBING- Rubber 2 1/4"	70309-09	x		1	24	SCREW- Cam	64102-A	x		1
4	FILTER- Oil	A-68593	x		1	25	GASKET	59736	x		1
5	LINE- Oil	A-59819	x		1	26	"O" RING	59074	x		2
	Includes:					27	SEAL- Felt	59926	x		1
6	GROMMET	59794	x		1	28	WORM	59675	x		1
7	CAP- Filler oil	A-63717-C	x		1	29	SCREW- Fil 8-32 x 3/4	80248	x		3
	Includes:					30	SCREW- Hex 12-24 x 9/16	80899	x		4
8	GASKET	56607	x		1	31	GASKET- Crankcase	63355	x		1
9	DRIVECASE	A-59930-H	x		1	32	LINE- Oil (Discharge)	A-59806	x		1
	Includes:						Includes:				
10	STUD- Guide bar, 3/8	67475	x		2	33	SLEEVE- Compression	25301	x		2
11	INSERT- Threaded	67476	x		2	34	FILTER- Oil (Manual oil)	A-59804-A	x		1
12	SEAL	58308-B	x		1	35	SCREW- (12-24 x 9/16)	80899	x		5
13	PLUG	28097	x		1	36	DRIVECASE	A-58925-E	x		1
14	GASKET- Oil reservoir	59710	x		1		Includes:				
15	COVER- Oil reservoir	59649-4A	x		1	37	SEAL	12282-A	x		1
16	SCREW- Rd. 6-32 x 1/2	80513	x		9	38	BEARING- Needle	58956	x		1
	SCREW- Set (not shown)	80742	x		1	39	PLUG- Button	94242	x		1
17	PIN- Cotter	86301	x		1	40	BOLT- Guide bar	67485	x		2
18	SCREW- Guide bar adjusting	63225	x		1	41	FITTING- Tube elbow (90° connection)	56707	x		1
19	PIN- Bar adjusting	93039	x		1						
20	NUT- Lock, 1/4-20	81204	x		1						

ALWAYS FURNISH MODEL AND SERIAL NUMBERS WHEN ORDERING PARTS.

XL-12/SXL-AO

FIGURE 5

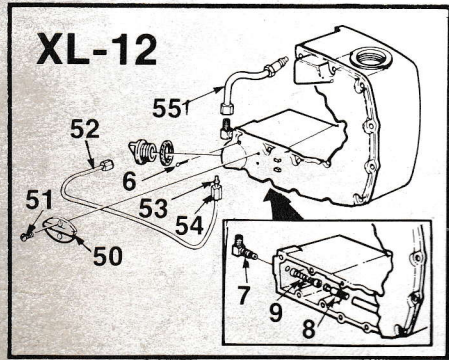
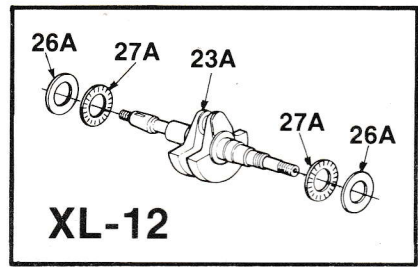
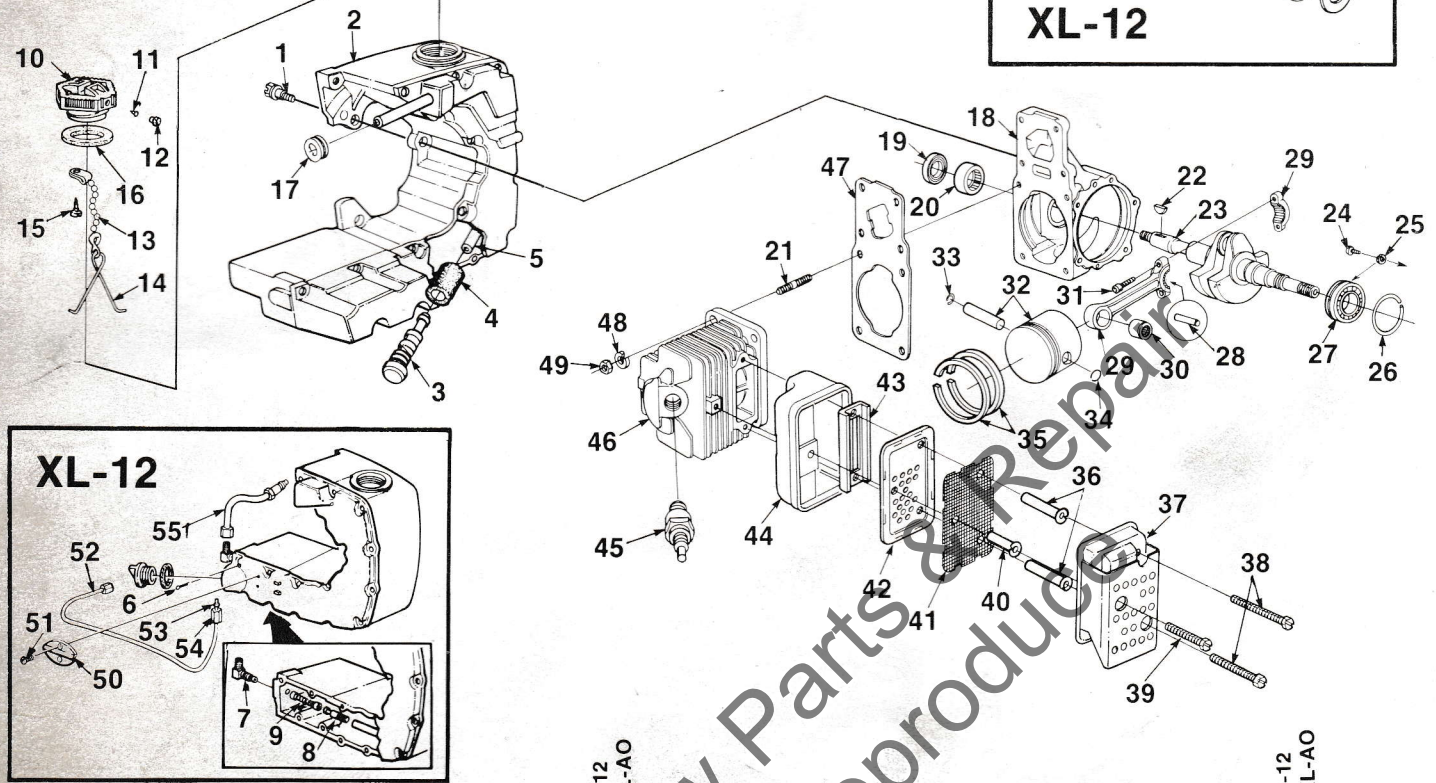

NO.	DESCRIPTION	PART NO.	XL-12	SXL-AO	QTY.	NO.	DESCRIPTION	PART NO.	XL-12	SXL-AO	QTY.
1	SCREW- Shoulder	63407	x	x	3	32	PISTON & PIN	A-58903-C	x		1
2	TANK- Fuel (Note 1)	A-63898-B	x	x	1		PISTON & PIN	A-68438		x	1
	TANK- Fuel (Note 1)	A-68345-A		x	1		Includes:				
3	FILTER- Fuel	A-69923	x	x	1	33	RING- Retaining	75120	x	x	1
	Includes:					34	RING- Retaining	64813	x	x	1
4	FELT- Filter	64083	x	x	1	35	PISTON RING	58877	x		2
5	TUBING- Fuel 9 1/4"	70310-37	x	x	1		PISTON RING	59436-1A		x	2
6	PIN- Cotter (Manual)	86301	x		1		MUFFLER ASSEMBLY (Note 2)	A-94219-A	x	x	1
7	VALVE- Inlet check (Manual)	A-59010	x		1	36	Includes:				
	Includes:					37	SPACER- Muffler	93983-01	x	x	2
	BALL (Not shown)	25527	x		1	38	CAP- Muffler & Shield	A-95988	x	x	1
8	FILTER- Oil (Manual)	A-59009-A	x		1		SCREW- Hex hd.				
9	LINE- Pick-up (Manual)	59000	x		1	39	(12-24 x 2 1/4)	94128	x	x	2
10	CAP- Fuel filler	A-69500-A	x	x	1		SCREW- Hex hd.				
	Includes:						(12-24 x 1 7/8)	94129	x	x	1
11	VALVE- Check	69451	x	x	1	40	SPACER- Muffler	93983-02	x	x	1
12	FILTER- Fuel cap	69454	x	x	1	41	SCREEN- Spark arrestor	93979	x	x	1
13	CHAIN- Bead	69502	x	x	1	42	BAFFLE- Muffler	93980	x	x	1
14	RETAINER	96535	x	x	1	43	PLATE- Muffler	94133-A	x	x	1
15	SCREW- Pan hd. #6 x 1/4	82256-A	x	x	1	44	BODY- Muffler	93981	x	x	1
16	GASKET- Fuel filler cap	69501	x	x	1	45	SPARK PLUG (CJ8)	63710-A	x		1
17	GROMMET	68046	x	x	1		SPARK PLUG (CJ6)	63547-S		x	1
18	CRANKCASE	A-65736	x	x	1	46	CYLINDER	A-69715	x		1
	Includes:						CYLINDER	A-69714		x	1
19	SEAL	12282-A	x	x	1		Includes:				
20	BEARING	58956	x	x	1	47	GASKET- Cylinder	*59771	x	x	1
21	STUD	55871	x	x	4	48	WASHER- Lock 1/4	83061	x	x	4
22	KEY- Woodruff	75078	x	x	1	49	NUT- 1/4-28	96212	x	x	4
23	CRANKSHAFT	63498-1	x		1	50	PLATE- Retaining	59016	x		1
23A	CRANKSHAFT	63497-1	x		1	51	SCREW- Pan hd. (4-40 x 1/4)	80919	x		2
24	SCREW- Torx	70306		x	2	52	LINE- Oil	A-59012	x		1
25	WASHER- Lock	59705		x	2		Includes:				
26	RING- Retaining	58319-A		x	2	53	SLEEVE- Compression (1/8)	25301	x		2
26A	RACE- Needle thrust	58725	x		1	54	NUT- Compression (5/16-24)	25302	x		1
27	BEARING- Ball	58190		x	2	55	LINE- Oil	A-94946		x	1
27A	BEARING- Needle thrust	58726	x		1						
28	ROLLER SET (31)	A-69054	x	x	1						
29	ROD- Connecting	A-63477-B	x	x	1						
	Includes:										
30	BEARING	93369	x	x	1						
31	SCREW- Cap soc. hd.	69919	x	x	2						

NOTE 1: Fuel tank gasket 65642 and screw 80513 are still available for tanks that have not been permanently bonded.

NOTE 2: Muffler A-59052-A has been superseded by A-94219-A muffler. Replacement studs 59065-B, Baffle 59050, caps A-63246-1, and spark arrestor DA-63500-A are still available.

FIGURE 6

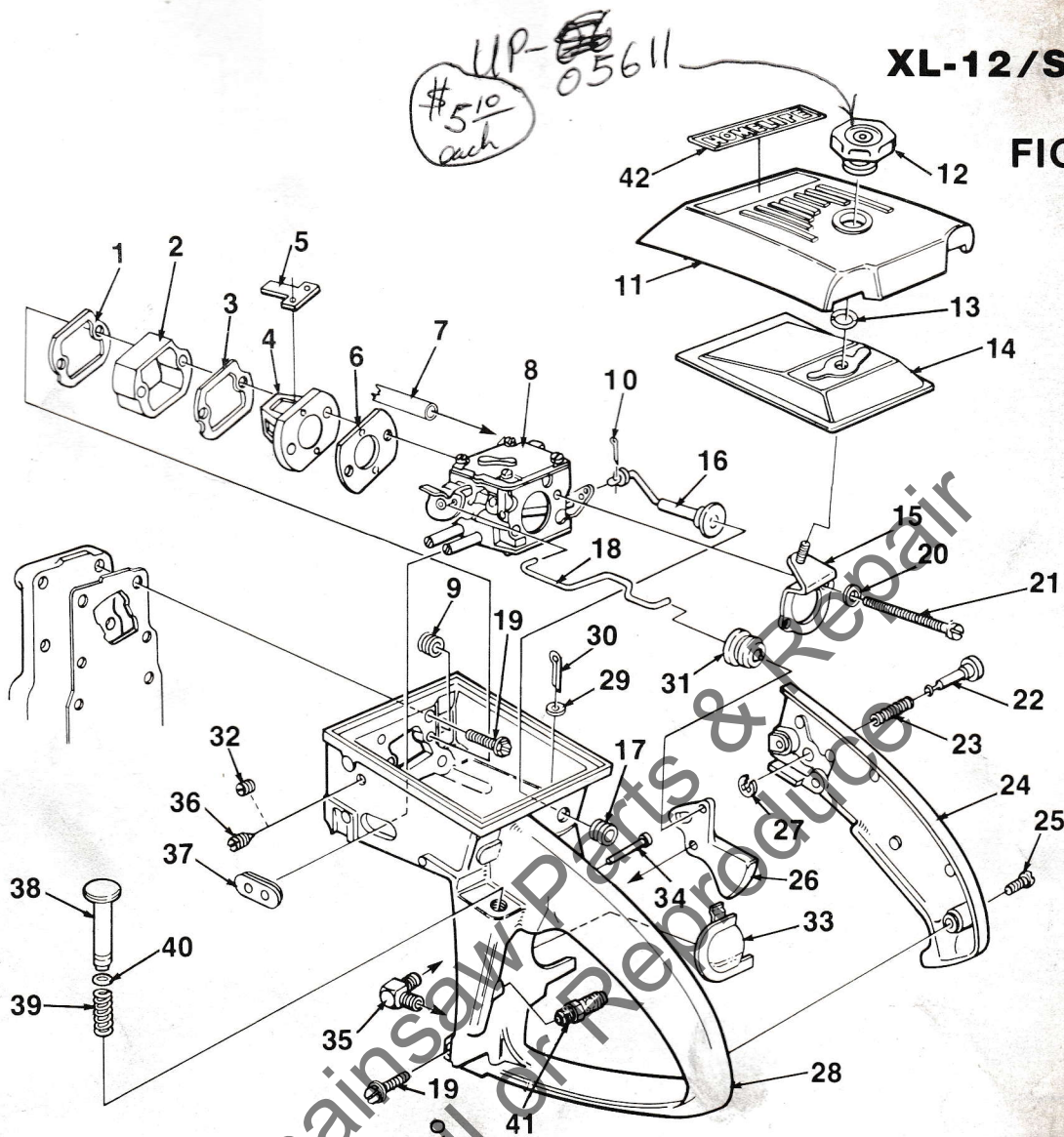

NO.	DESCRIPTION	PART NO.	XL-12	SXL-AO	QTY.	NO.	DESCRIPTION	PART NO.	XL-12	SXL-AO	QTY.
1	GASKET- Spacer	59274	x	x	1	23	SPRING- Throttle latch	58405	x	x	1
2	SPACER	59718	x	x	1	24	COVER- Throttle handle	A-59213-1A	x	x	1
3	RETAINER- Reed valve	63260-A	x	x	1		Includes:				
4	SEAT- Reed valve	63263	x	x	1		Bushing- Pin (Not shown)	67752	x	x	1
5	VALVE- Reed	59678-B	x	x	4	25	SCREW- Pan 8-32 x 1/2	80560	x	x	2
6	GASKET- Carburetor	59722	x	x	1	26	TRIGGER- Throttle	58859	x	x	1
7	LINE- Fuel 9 1/4" (Note 1)	70310-37	x	x	1	27	RING- Retaining	58409	x	x	1
8	CARBURETOR- Walbro (SDC-62)	A-68371-B	x	x	1	28	THROTTLE HANDLE	A-93926	x	x	1
	CARBURETOR- Tillotson (HS-179-B)	A-68363-BS	x	x	1		Includes:				
	CARBURETOR- Zama (#20-20)	A-94953	x	x	1	29	WASHER- Felt	63290	x	x	1
9	GROMMET	68279	x	x	1	30	PIN- Cotter	86301	x	x	1
10	PIN- Cotter	86324	x	x	1	31	BOOT- Throttle rod	67634	x	x	1
11	COVER- Air filter	58773-12	x	x	1	32	PLUG	63303	x	x	1
12	NUT- Air filter cover	A-65272	x	x	1	33	SHIELD- Spark plug	93209	x	x	1
13	RING- Retaining	58319-A	x	x	1	34	PIN	94142	x	x	1
14	ELEMENT- Air filter	63589-A	x	x	1	35	VALVE- Check	A-59011	x	x	1
15	BRACKET- Mounting	A-59822-B	x	x	1	36	SCREW- Idle	63302-B	x	x	1
16	ROD- Choke	68130-1	x	x	1	37	GROMMET- Hi-Lo	59770	x	x	1
17	GROMMET	58362	x	x	1	38	PLUNGER- Spring	A-93783	x	x	1
18	ROD- Throttle	59763	x	x	1		Includes:				
19	SCREW- Hex 12-24 x 7/8	80891	x	x	5	39	SPRING- Compression	59293	x	x	1
20	WASHER- Lock #10	83046	x	x	2	40	"O" RING	74388	x	x	1
21	SCREW- Hex 10-32 x 2 11/16	80921	x	x	2	41	VALVE- Check	A-59818			1
22	PIN- Throttle latch	95671	x	x	1	42	LABEL- Homelite	96479	x	x	1

NOTE 1: The 63745-A fuel line is available for A-58767-C (HS-4D) Carburetor.

ALWAYS FURNISH MODEL AND SERIAL NUMBERS WHEN ORDERING PARTS.

FIGURE 7

**Carburetor
(SDC-62)
A-68371-B**

- 67020 Repair Kit (1-19)
- 70811 Diaphragm & Gasket Kit (16-19)
- 93910-A Check Valve Kit (20)
- 64229 Inlet Needle (5)

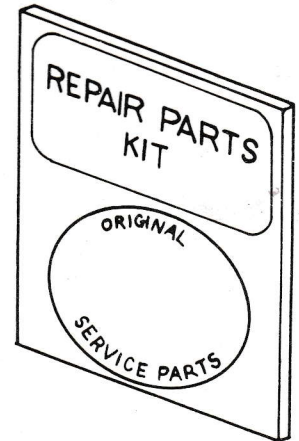
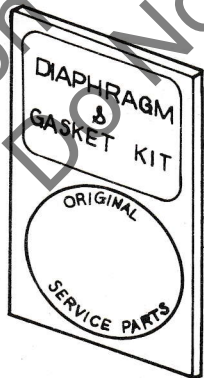
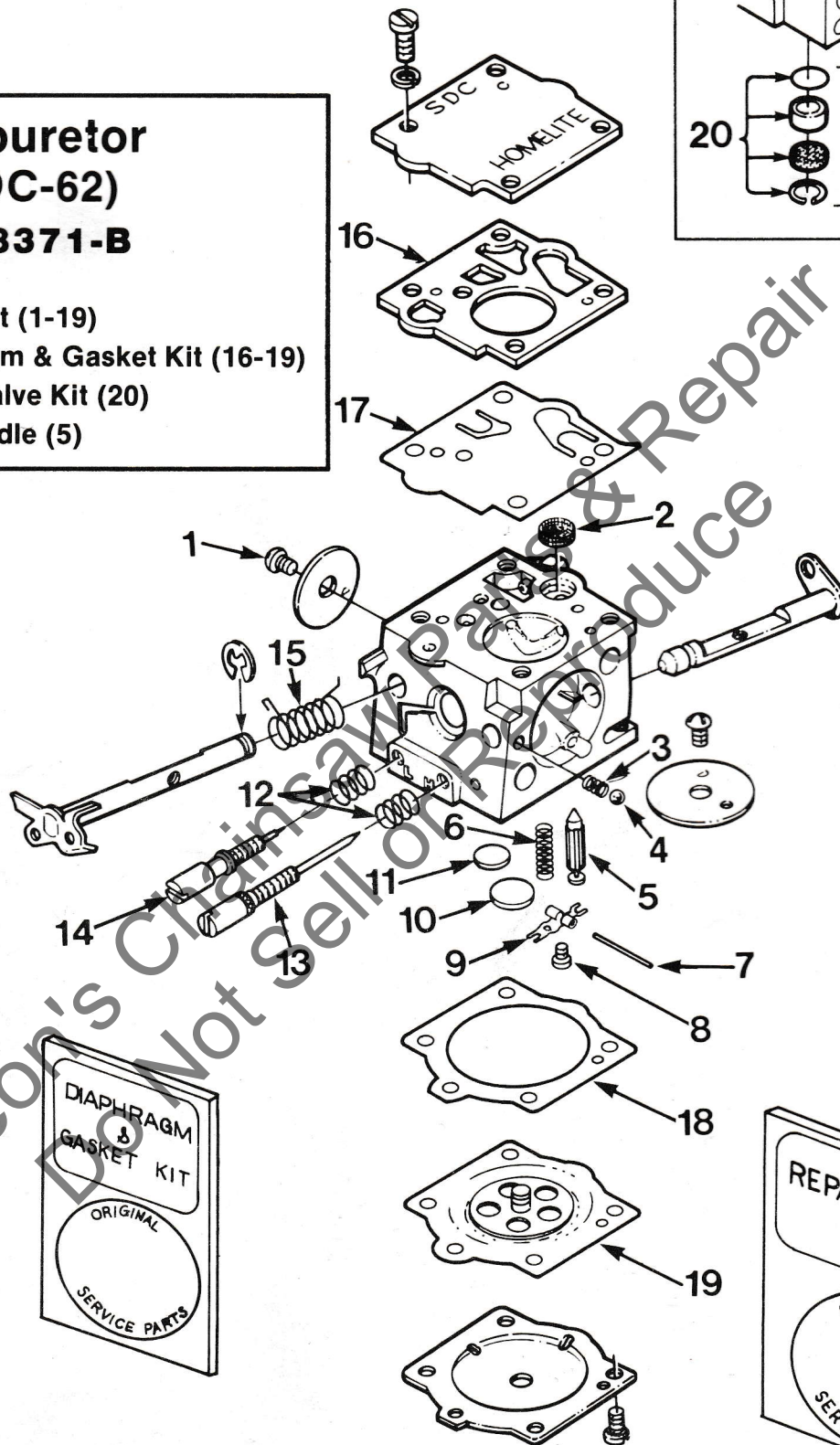
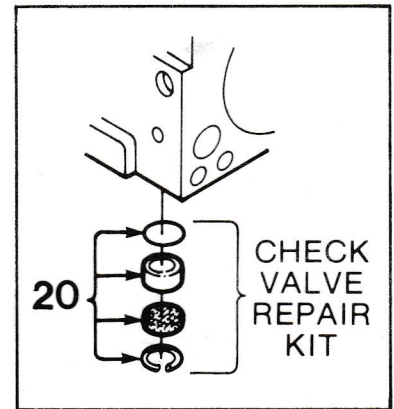

ALWAYS FURNISH MODEL AND SERIAL NUMBERS WHEN ORDERING PARTS.

FIGURE 8

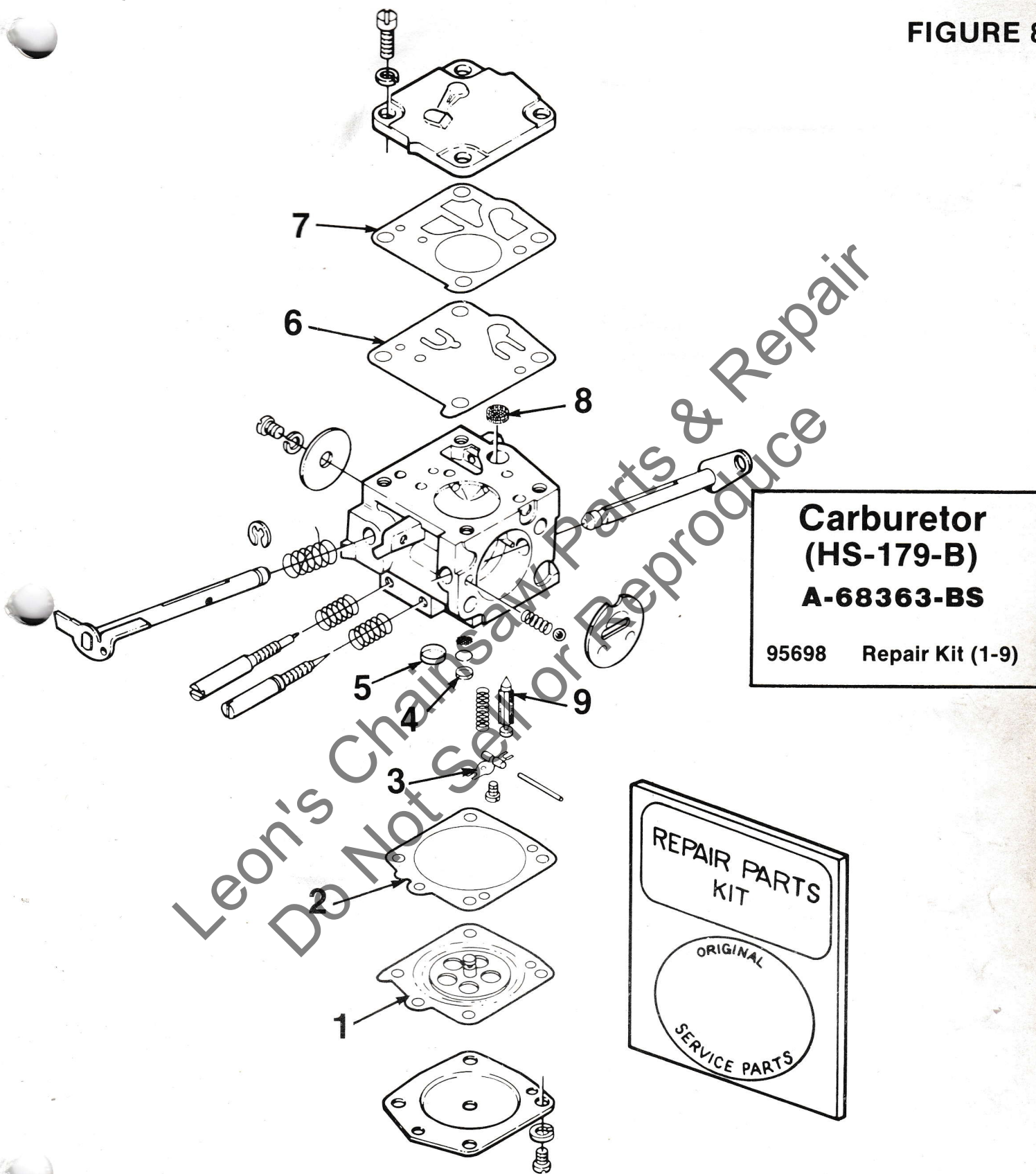

ALWAYS FURNISH MODEL AND SERIAL NUMBERS WHEN ORDERING PARTS.

FIGURE 9

**Carburetor
(ZAMA #20-02)
A-94953**

- 94954 Repair Kit (1-16)
- 94952 Diaphragm & Gasket Kit (13-16)

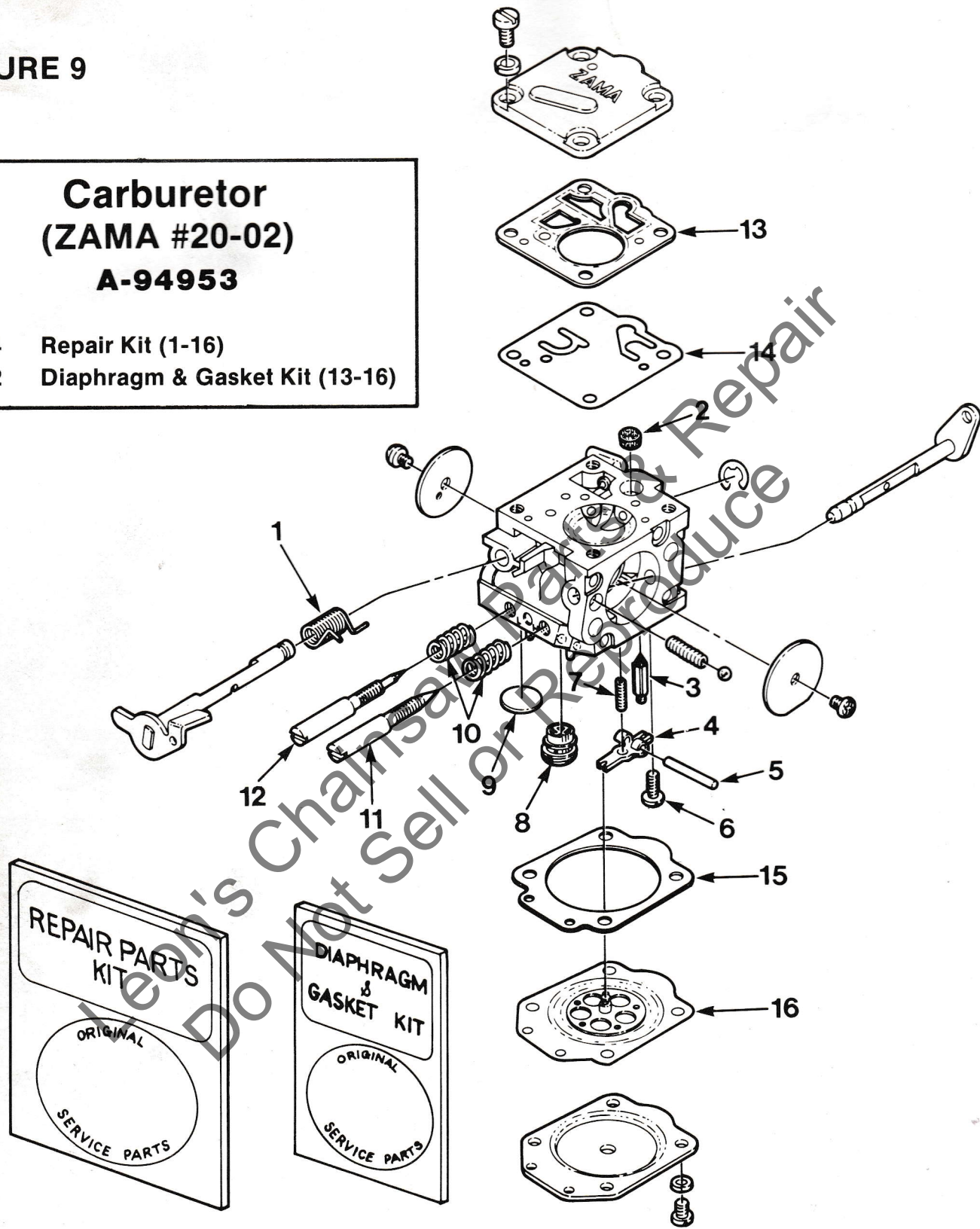

ALWAYS FURNISH MODEL AND SERIAL NUMBERS WHEN ORDERING PARTS.

TOOLS FOR XL-12

DESCRIPTION	PART NO.
PLIERS- Piston snap ring	22828
PLUG- Bearing assembly & disassembly	23756
PLUG- Bearing assembly & disassembly Drive & Crankcase	23757
PLUG- Seal assembly-drive & crankcase	23758
PLUG- Piston pin removal	A-23949
Includes:	
"O" RING	67900
PULLER- Magneto remover	A-24290
SLEEVE- Seal protecting-crankcase	23759
SLEEVE- Seal installation-drive and crankcase	23800
WRENCH- Hex socket screw (conn rod)	23528
WRENCH- Spanner to assembly & disassemble clutch	A-23934
Includes:	
PIN	23954
WRENCH- Socket	68651
SCREWDRIVER	24541
TOOL- Clutch removal (for clutch conversion kit)	A-17146

TOOLS FOR THE SXL-AO

DESCRIPTION	PART NO.
ANVIL- Crankshaft	23846-4
COLLAR- Ball bearing installation	22820-1
DRIVER- Check valve (for SDC carburetor)	24173
JACKSCREW	A-23137
PLIERS- Piston snap ring	22828
PLUG- Bearing assembly connecting rod	23756
Drive & Crankcase	23757
PLUG- Seal assembly - drive & crankcase	23758
PLUG- Seal installation	23845
Drivecase assembly	A-23949
PLUG- Piston pin removal	A-23949
Includes:	
"O" RING	67900
PULLER- Magneto remover	A-24290
SLEEVE- Bearing & Shaft installation	23884-A
SLEEVE- Bearing & Shaft installation	23136-2A
SLEEVE- Seal protecting	23844
SLEEVE- Seal protecting crankcase	23759
SLEEVE- Seal installation drivecase	23843
SLEEVE- Seal installation drive & crankcase	23800
WRENCH- Hex socket screw (connecting rod)	23528
WRENCH- Spanner to assemble & Disassemble clutch	A-23934
Includes:	
PIN	23954
WRENCH- Socket	68651
WRENCH- Insert	A-24322
SCREWDRIVER	24541
TOOL- Clutch removal (for clutch conversion kit)	A-17146
BIT- Driver torx 1/4" hex shank	24982-01
BIT- Driver torx 5/16" hex shank	24982-02

ACCESSORIES

DESCRIPTION	PART NO.	XL-12	SXL-AO
CLUTCH- Conversion Kit (Lined)	A-96745	1	1
Includes:			
SHOE- Clutch	A-93632-A	3	3
SPIDER- Clutch	93639	3	3
SPRING- Clutch	93814-A	3	3
SPROCKET & DRUM	A-95465	1	1
THRUST WASHER	93643	1	1
THRUST WASHER	93650	1	1
THRUST WASHER	65064	1	1
KIT- Manual oil pump (Prior to s/n 50440501)	A-65868		1
Includes:			
BUTTON	57289-1		1
LINE- Oil	A-59819		1
Includes:			
GROMMET	59794		1
VALVE- Check	A-59818		1
FILTER- Oil (intake)	A-59804-A		1
PLUNGER	A-57834-10		1
Includes:			
"O" RING	74388		1
"O" RING	59074		1
SPRING	59293		1

When this Kit is assembled to the unit, the unit will have a complete manual oil pump system.

KIT- Hand guard	A-70910-A		1
Includes:			
WASHER	58851-2		1
WASHER	70788		1
SLEEVE	70911		1
SCREW- Machine flat hd.	70926		1
SCREW	80945		1
NUT	81225		1
SCREW	82223		1
DECAL	96990		1
KIT- Hand Guard	A-70944-A		1
WASHER	58851-2		1
WASHER	70788		1
SLEEVE	70911		1
SCREW	80945		1
NUT	81225		1
KIT- Safe•T•TIP (Standard)	DA-70790-A		1
Includes:			
SCREW	82335		1
CARRY CASE	95920		1
REEL- Starting rope (250 Ft.) #5	57084-1		1
KIT- Insert (for drivecase guide barstuds)	A-70370-A		1
TUBING- Rubber 10 ft. (Fuel)	70310-99		1
TUBING- Rubber 10 ft. (Oil)	70309-99		1
THROTTLE HANDLE			
CONVERSION KIT (For the XL-12 single reed system)	A-97553		1

PAINT

DESCRIPTION	PART NO.	XL-12	SXL-AO
LACQUER- Red	23475	1	1
LACQUER- Black	22772	1	1

HOMELITE DIVISION OF TEXTRON INC.

P.O. Box 7047
14401 Carowinds Boulevard
Charlotte, N.C. 28217

OVERSEAS OFFICES

HOMELITE DIVISION OF TEXTRON INC.

Korenaarstraat 1
2153 BM Nieuw Vennepe
The Netherlands

HOMELITE DIVISION OF TEXTRON INC.

Pacific Limited
P.O. BOX 209
Blackburn, 3130
Victoria, Australia

Leon's Chainsaw Parts & Repair
Do Not Sell or Reproduce

44812RY

HOMELITE **TEXTRON**

Homelite Division of Textron Inc.