

PARTS LIST

HOMELITE®

CHAIN SAWS

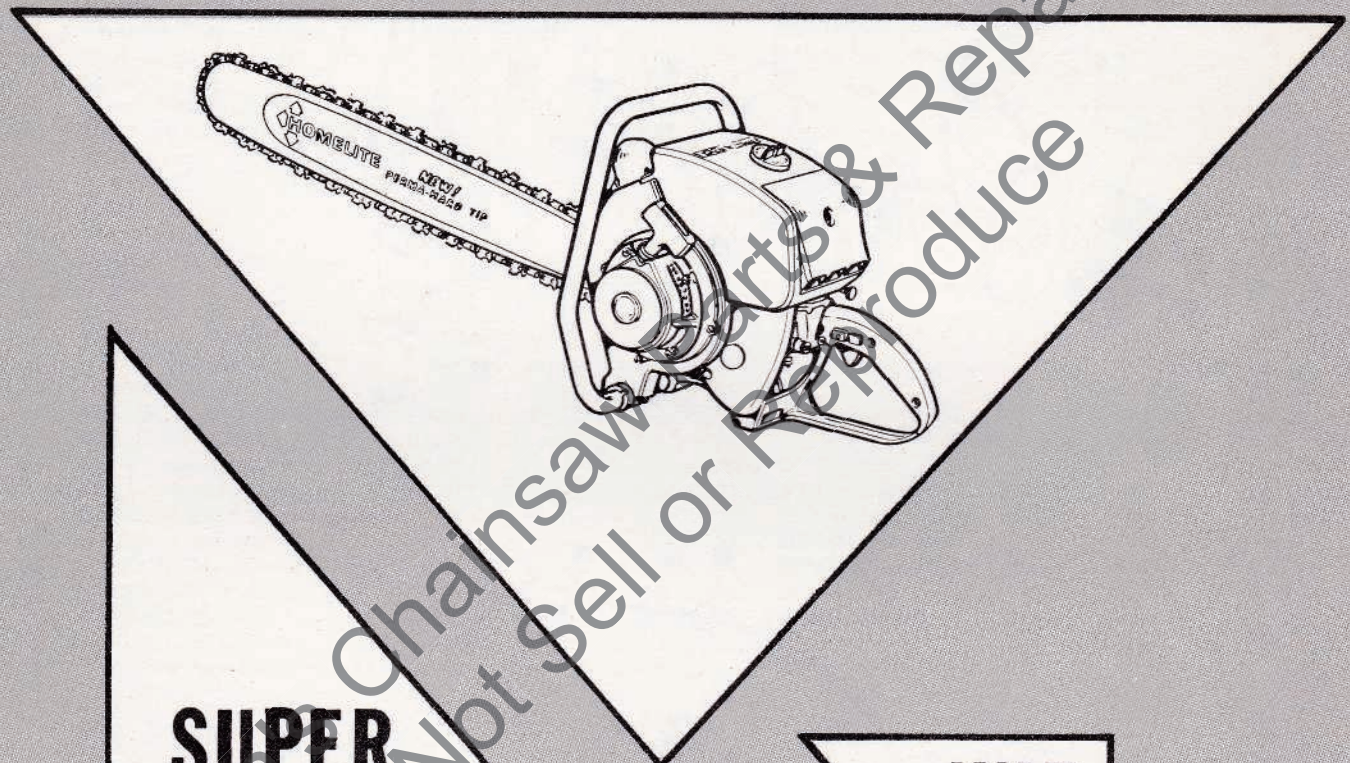

Learn Chainsaw Parts & Repair
Do Not Sell or Reproduce

**SUPER
WIZ**

55 • 66 • 80

**WIZ
55**

HOMELITE®

Extron
DIVISION

PORT CHESTER, N.Y. U.S.A.

PRINTED IN U.S.A.

Price .35

PART NO. 24438 - A

WIZ 55 • SUPER WIZ 55 • 66 • 80 CHAIN SAWS

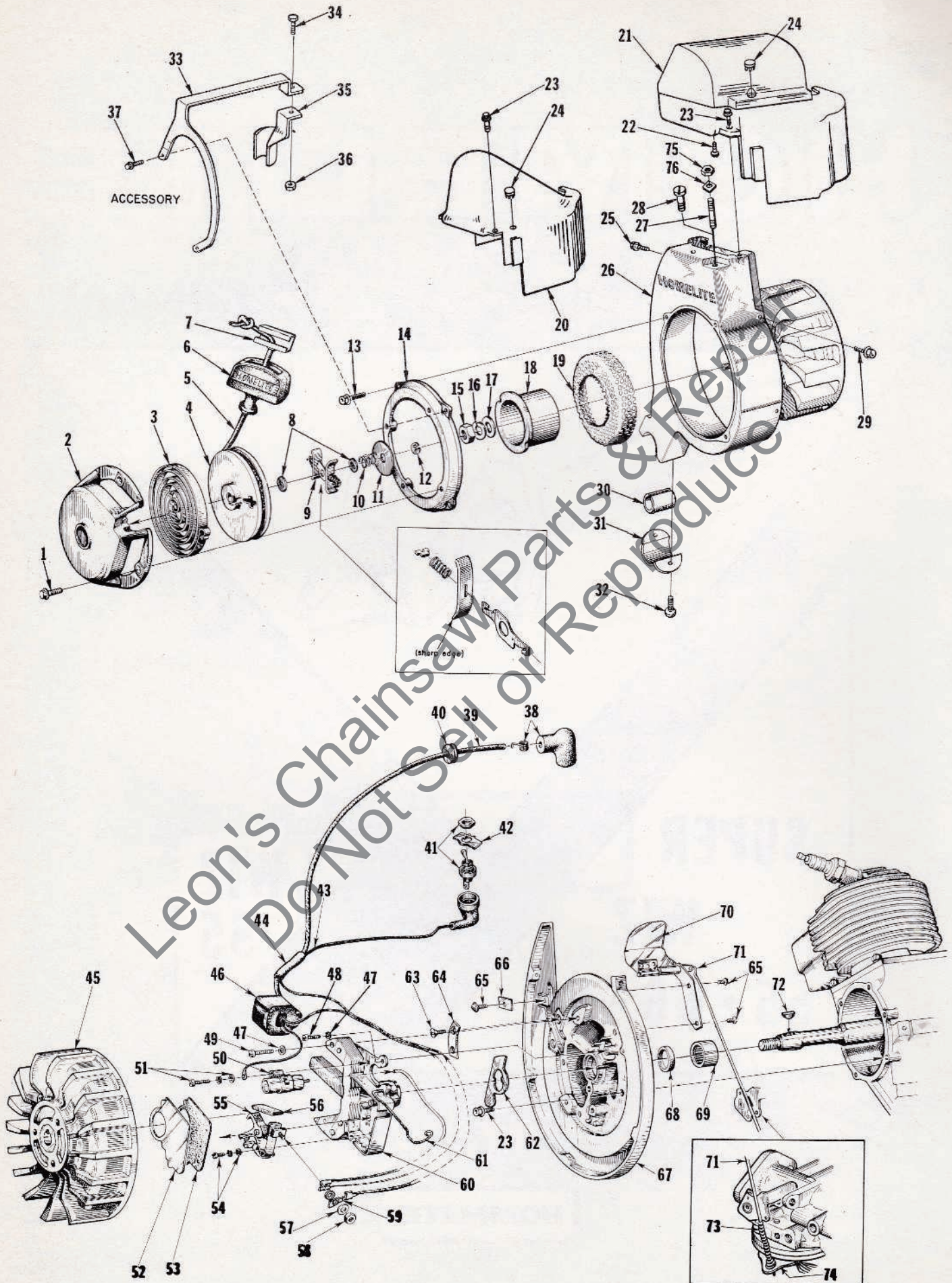

WIZ 55 • SUPER WIZ 55 • 66 • 80 CHAIN SAWS

No.	Description	Part No.	Wiz, Super Wiz				No.	Description	Part No.	Wiz, Super Wiz			
			55	66	80	Qty.				55	66	80	Qty.
1	SCREW-hex, 1/4-20 x 1/2	80681-3	x	x	x	4	38	TERMINAL-spark plug	A-55373-A	x	x	x	1
2	COVER-starter	A-56450-2A	x	x	x	1	39	LEAD-high tension	55235-A	x	x	x	1
3	SPRING-rewind	56451-1	x	x	x	1	40	GROMMET	60929	x	x	x	1
4	PULLEY-starter	56452	x	x	x	1	41	SWITCH-toggle	A-57716	x	x	x	1
5	ROPE-starting	55898	x	x	x	1		Includes:					
6	GRIP-starting	55937	x	x	x	1	42	PLATE-"On-Off"	55879	x	x	x	1
7	INSERT-grip	58517	x	x	x	1	43	LEAD-ground	A-57738	x	x	x	1
8	WASHER-brake	58970	x	x	x	2	44	SLEEVE-insulating	55290	x	x	x	1
9	SHOE-friction	A-57647	x	x	x	1	45	ROTOR	57579-A	x	x	x	1
10	SPRING-brake	56455	x	x	x	1	46	COIL	55986-A	x	x	x	1
11	WASHER-retaining	76436	x	x	x	1	47	WASHER-lock, #10	83046	x	x	x	3
12	RING-retaining	67906	x	x	x	1	48	SCREW-fil., 10-24 x 1/2	80595	x	x	x	1
13	SCREW-hex, 12-24 x 9/16	80899	x	x	x	2	49	SCREW-fil., 10-24 x 7/8	80660	x	x	x	2
14	RING-starter mtg.	56531-6	x	x	x	1	50	CONDENSER-w/terminal	55987	x	x	x	1
15	NUT-jam, 7/16-20	81110	x	x	x	1	51	SCREW GROUP-condenser	57750	x	x	x	1
16	WASHER-lock, 7/16	83019	x	x	x	1	52	COVER-breaker box	55979	x	x	x	1
17	WASHER-flat, 7/16	84055	x	x	x	1	53	GASKET-cover	55978-2	x	x	x	1
18	CUP-starter	56441-1	x	x	x	1	54	SCREW GROUP-point	57749	x	x	x	1
19	SCREEN-air	56442	x	x	x	1	55	POINTS-breaker (set)	A-58165	x	x	x	1
20	SHIELD-cylinder	A-59588-1	x	x		1	56	Includes: WICK-felt	55984	x	x	x	1
21	SHIELD-cylinder	A-68108-1			x	1	57	WASHER-terminal	55983	x	x	x	1
	Includes:						58	NUT-terminal	55982	x	x	x	1
22	SCREW-rd. hd., 6 x 1/2	80513			x	4	59	TAB-ground lead	57733	x	x	x	1
23	SCREW-hex, 10-32 x 9/16	80825	x	x	x	8	60	BOX-breaker w/core	57744	x	x	x	1
24	PLUG-button	32814	x	x	x	1	61	CLIP-cover	55980	x	x	x	1
25	SCREW-hex, 12-24 x 3/8	80837	x	x	x	2	62	SEAL-felt	56292-A	x	x	x	1
26	HOUSING-fan	A-57542-5	x	x	x	1	63	SCREW-flat, 6-32 x 5/16	80598	x	x	x	2
27	STUD-fuel tank	73730			x	1	64	CLAMP-inner	55962	x	x	x	1
28	SCREW-fil., 1/4-20 x 1/4	80325-2	x			1	65	SCREW-pan., 8-32 x 1/4	80575	x	x	x	3
29	SCREW-hex, 10-24 x 3/8	80869-1	x	x	x	1	66	CLAMP-outer	55161	x	x	x	1
30	CUSHION-handle	56281	x	x	x	1	67	PLATE-back	A-63179	x	x	x	1
31	CLAMP-handle, fan housing	56282-A	x	x	x	1	68	Includes: SEAL	56134	x	x	x	1
32	SCREW-hex, 12-24 x 1/2	80821	x	x	x	2	69	BEARING-needle	57533	x	x	x	1
33	KIT-fuel tank bracket	A-64901	x	x	x	1	70	GOVERNOR	A-58222-3		x	x	1
	KIT-fuel tank bracket	A-64846	x			1	71	ROD-governor	A-63046		x	x	1
	STRAP-reinforcing included in kit						72	KEY-rotor	75078	x	x	x	1
	Includes:						73	SPRING-governor	63047		x	x	1
34	SCREW-hex, 1/4-20 x 13/16	80573	x	x	x	1	74	BRACKET-governor spring	63048	x	x	x	1
35	BRACKET-strap	63143-1	x	x	x	1	75	NUT-1/4-28	81114		x	x	1
	BRACKET-strap	63181-1	x			1	76	WASHER-square	59348		x	x	1
36	NUT-lock, 1/4-20	81108	x	x	x	1							
37	SCREW-hex, 12-24 x 11/16	80751	x	x	x	2							

TOOLS

A-22308	COMBINATION WRENCH
A-22560	REMOVER-rotor
A-23696-A	REMOVER-threaded spider
23136-2	BODY-jackscrew
23232	SLEEVE-crankcase seal
22820-1	COLLAR-main bearing
A-23137	JACKSCREW
22812-1	PLATE-shaft aligning
23391-1	PLUG-back plate needle bearing
23233	PLUG-back plate, crankcase seal
23228	PLUG-sprocket shaft bearing
22828	PLIERS-piston snap ring
22726	PLIERS-snap ring
23528	WRENCH-socket screw (conn. rod) - 55 & 66
A-23809	PLUG-conn. rod needle bearing
23267	ANVIL-sprocket shaft
23710	SPANNER-starter cup
23234	PLUG-conn. rod, needle bearing
22126	WRENCH-socket screw (conn. rod) - 80

DECAL

#23742 (universal replacement) composed of "DIRECT DRIVE", "GEAR DRIVE", "STARTING INSTRUCTIONS", and two "HOMELITE" (letters 1/4" and 1/2" high).

OIL

55291-C GEAR OIL- 1 pt.

PAINT

24101 SPRAY CAN-blue
 24453 SPRAY CAN- "70" blue
 23475 SPRAY CAN-red
 22772 SPRAY CAN-black

AVAILABLE:

Complete STARTER ASSEMBLY #A-56540-6, includes index #2 thru #12, #18 and #19.

WIZ 55 • SUPER WIZ 55 • 66 • 80 CHAIN SAWS

No.	Description	Part No.	Wiz, Super Wiz			No.	Description	Part No.	Wiz, Super Wiz		
			55	66	80 Qty.				55	66	80 Qty.
1	COVER-air filter	A-57696-A	x	x	1	54	GASKET	72174	x		1
2	Includes: SCREW NUT (not shown)	57994	x	x	1	55	LINE-fuel	72107-A	x		1
		81163	x	x	1	56	FITTING-fuel	A-72475	x		1
3	FILTER-air	58036	x	x	1	57	SCREW-flat, 6-32 x 3/8	80451	x		4
4	GASKET-filter	57993	x	x	1	58	FITTING-fuel elbow	74917	x		1
5	GASKET-stud	57991	x	x	1	59	LINE-fuel w/spring	A-56379	x		1
6	STUD-mounting	57996	x	x	1	60	SCREW-hex, 1/4-20 x 13/16	80573	x	x	5
7	LINE-fuel	55680	x	x	1	61	BUMPER-spiked	55103-1	x	x	1
8	FITTING-fuel	57652	x	x	1	62	HANDLE BAR-flush cut	A-57673-2	x	x	1
9	LINE-fuel	55805	x	x	1		HANDLE BAR-wrap-around	A-57671		Optional	1
10	FILTER-fuel	A-59251	x	x	1	63	FITTING-elbow	31734	x	x	1
11	Includes: FILTER	59253-1	x	x	1	64	FITTING-straight	68393	x	x	1
		A-64140-1	x	x	1	65	WASHER-lock, 5/16	83003	x	x	2
12	Includes: GASKET	65358	x	x	1	66	SCREW-hex, 5/16-18 x 1-1/2	80087	x	x	2
		63718	x	x	1	67	STRAP-fuel tank	59347	x	x	1
14	DECAL-caution	64144	x	x	1	68	GASKET	55116	x	x	1
		A-65324-A	x	x	1	69	SCREW-pan, 10-32 x 3/4	80583	x	x	3
15	Includes: GASKET-fuel tank	67749	x	x	1		VALVE-reed	A-55958-1	x	x	1
		57595-3A	x	x	1	70	SEAT-reed valve	55932-7	x	x	1
17	COVER-fuel tank	57595-3A	x	x	1	71	REFD	55941-1	x	x	4
18	SCREW-fil., 8-32 x 3/4	82156	x	x	1	72	CLAMP-reed	55942	x	x	4
19	GROMMET	64473	x	x	2	73	SCREW-pan, 4-40 x 3/16	80658	x	x	8
20	SCREW-pan, 8-32 x 5/8	82177	x	x	1	74	WASHER-lock, 1/4	83009	x	x	2
21	SCREW-fil, 8-32 x 1-7/16	82187	x	x	7	75	NUT-1/4-20	81013-1	x	x	2
22	SCREW-fil, 8-32 x 5/8	82146	x	x	3	76	SLEEVE-rod	63024	x	x	1
23	SCREW-shoulder	64133-A	x	x	1	77	SCREW-pan, 10-32 x 1, See Note 3	80624	x		2
		A-63717-A	x	x	1	78	ELBOW-air, See Note 3	55019-13	x		1
25	Includes: GASKET	56607	x	x	1	79	GASKET	55059	x		1
		63718	x	x	1	80	ROD-throttle	A-55954	x	x	1
26	LINE-oil	A-55191	x	x	1	81	Includes: SPRING	55045-A	x	x	1
27	VALVE-check	A-59456-A	x	x	1	82	TRIGGER-throttle	A-55207	x	x	1
28	FILTER-oil	A-59449	x	x	1	83	HANDLE-throttle w/pin	A-63178	x	x	1
29	LINE-oil filter	59000	x	x	1		Includes: PAD-felt (not shown)	55372	x	x	1
30	GASKET-seat	55110	x	x	1	84	SCREW-hex, 12-24 x 1/2	80821	x	x	2
31	SEAT-check valve	59450	x	x	1	85	COVER-handle	A-55228	x	x	1
32	GASKET	55107	x	x	1		Includes: LOCK-throttle (not shown)	A-55282	x	x	1
33	CAP-check valve	A-55167	x	x	1	86	SPRING	72970	x	x	1
34	SPRING-valve	59022	x	x	1	87	SCREW-pan, 8-32 x 1/2	80560	x	x	4
35	BALL-check	25527	x	x	1	88	SHIELD-carburetor, See Note 1	55104-9	x	x	1
36	SPRING	59293	x	x	1	89	CARBURETOR-See Note 2	A-58102	x	x	1
37	PLUNGER-oil	A-57834-10	x	x	1	90	Includes: BRACKET-spring	63048	x	x	1
38	Includes: "O" RING	74388	x	x	1	91	GASKET	55553-3	x	x	1
		59074	x	x	1	92	GASKET	55946	x	x	1
39	"O" RING	59074	x	x	1	93	STUD	55945	x	x	2
40	BUTTON	57289-A	x	x	1	94	SPACER-reed valve	55933-1	x	x	1
41	SCREW-hex, 12-24 x 5/8	80676	x	x	1	95	BRACE	58549-A	x	x	1
42	ELBOW-air	57618-2	x	x	1	96	CUSHION-handle	55146	x	x	1
43	GASKET	72971-2	x	x	1	97	SCREW-hex, 1/4-20 x 5/8	80581	x	x	4
44	GASKET	57659	x	x	1	98	ROD-throttle, See Note 2	63577	x		1
45	SPRING-compression	63031	x	x	2	99	PIN-spring, See Note 2	63579	x		1
46	SCREW-pan, 10-32 x 1-3/16	80841	x	x	2	100	SPRING-throttle, See Note 2	63578	x		1
47	SCREW-pan, 6-32 x 1/2	80639	x		2	101	VALVE-reed w/studs, See Note 3	A-55800-A	x		1
48	CAP-air filter	55066-2	x		1	102	STUD-See Note 3	27464	x		2
49	FILTER-air	57172-B	x		1		STRAP-reinforcing (not shown)	68035	x		1
50	GASKET-filter	57173	x		1	COVER-fuel tank (not shown)	57595-3	x		1	
51	TANK-fuel	A-55568-2	x		1		for older units				
52	NUT-1/4-20, See Note 4	81114	x	x	3						
		81114			x	2					
53	WASHER-square, See Note 4	59348	x	x	1						

Note 1 - Service replacement SHIELD #55104-9 does not have hole for large PLUG (button) #56533, used in early WIZ "55" only; not required in later models.

Note 2 - Service replacement CARBURETOR #A-58102 (HL-117C) supplied with #56175 throttle friction spring installed, and #75756 throttle opening spring packaged with assembly.

On WIZ "66" models use carburetor as supplied, discard #75756 spring.

On WIZ "55" models equipped with index #91, #98, #99, and #100 use carburetor as supplied, discard #75756 spring.

On WIZ "55" models (originally equipped with HL-46B or HL-204A carburetors) remove and discard #56175 spring, thread #75756 spring onto other end of throttle shaft (an anchor pin is provided); loosen turret screw, turn inlet position 180°, tighten screw.

Use Repair Parts Kit #57987, Gasket Set #57919 for HL-117C and HL-204A models: refer to #23621-A Rev. 1 Carburetor Sheet.

Note 3 - For units below serial number 2537289 use #55019-11 Elbow, #80638 Screw, #A-55800-A Valve, including #27464 Stud.

Note 4 - Service replacement crankcase A-64902-A and fuel tank A-65324-A require two (2) grommets #64473 (supplied with A-65324-A tank and A-64902-A crankcase) and one (1) shoulder screw #64133-A. When using new tank A-65324-A and old crankcase A-63717-A (with 1/4" stud) use only one (1) grommet on top of mounting tab and fasten with a square washer and lock nut. If the new crankcase A-64902-A is used with the old tank you should drill out the hole in the crankcase mounting tab to a 3/8" diameter, insert grommets #64473 on both sides and fasten with shoulder screw #64133-A.

The above drilling and fastening methods can also be used on WIZ "55" with the new crankcase A-64902-A.

WIZ 55 • SUPER WIZ 55 • 66 • 80 CHAIN SAWS

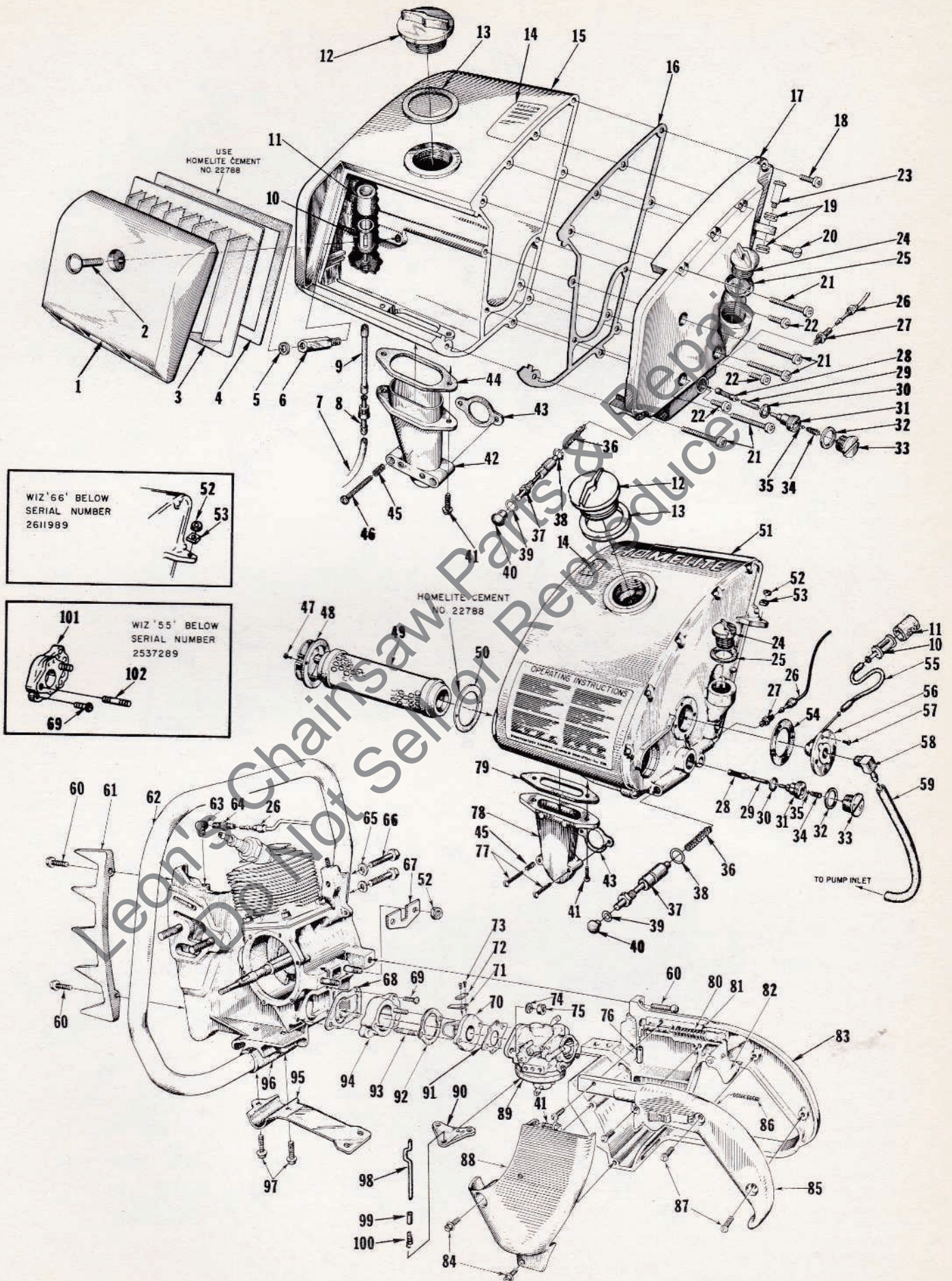

WIZ 55 • SUPER WIZ 55 • 66 • 80 CHAIN SAWS

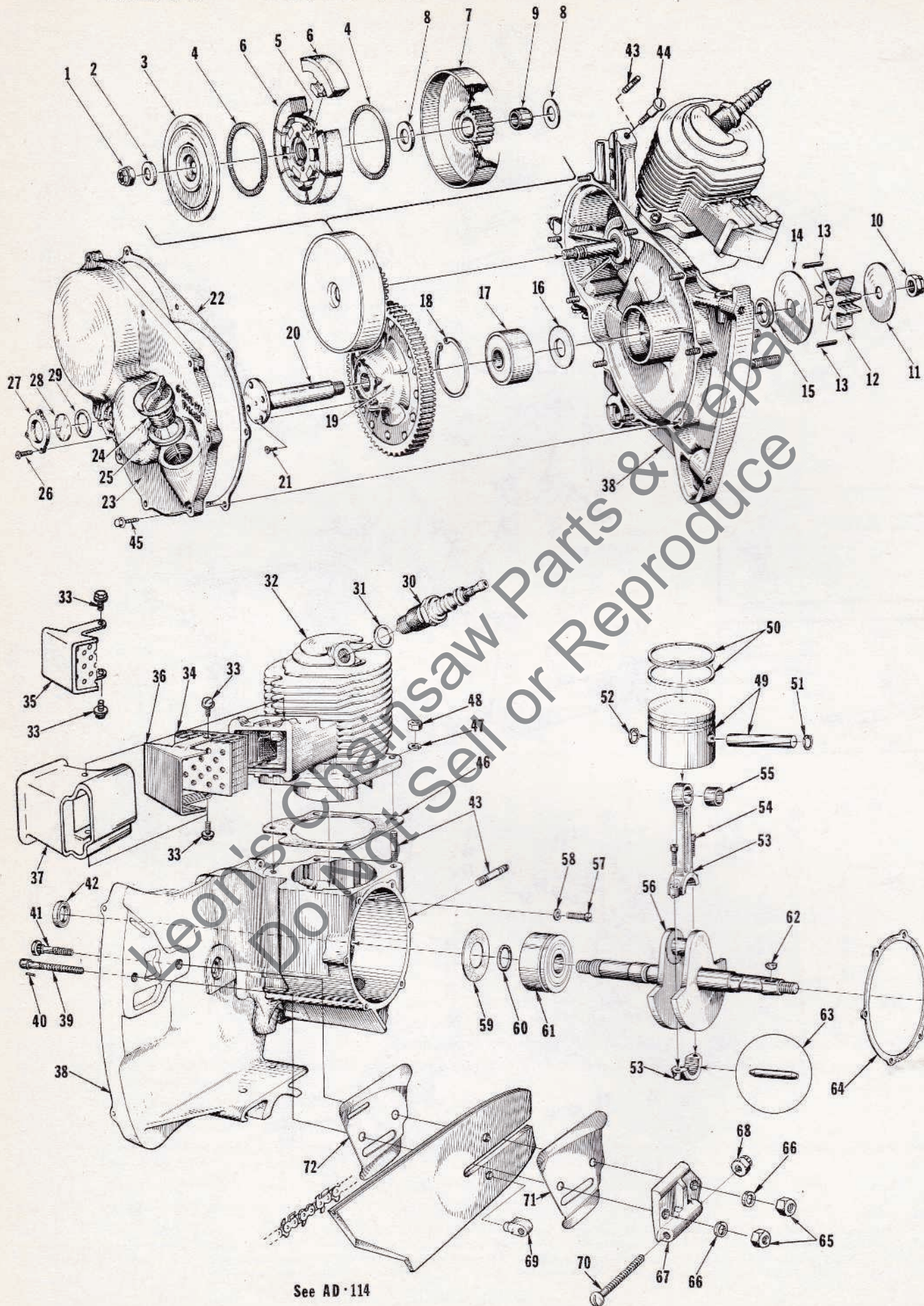

See AD-114

WIZ 55 • SUPER WIZ 55 • 66 • 80 CHAIN SAWS

No.	Description	Wiz, Super Wiz				No.	Description	Wiz, Super Wiz			
		Part No.	55	66	80 Qty.			Part No.	55	66	80 Qty.
1	NUT-3/8-24	81192	x	x	x 1	33	SCREW-hex, 10-24 x 3/8	80869-1	x	x	x 2
2	WASHER-clutch	55036	x	x	x 1		SCREW-pan, 10-24 x 1/2	80672			x 2
3	COVER-clutch	55126-A	x	x	x 1	34	MUFFLER	A-56068-A	†	x	x 1
	heavy duty, See Note 1	58023-A	†	†	x 1	35	MUFFLER	A-56613-A	x		x 1
4	SPRING-clutch	55123-C	x	x	x 2	36	CAP-muffler, See Note 3	56396	†	x	x 1
5	SPIDER-clutch	58546-3	x	x	x 1	37	DAMPER-heat	55506-5			x 1
	heavy duty, See Note 1	58547-2	†	†	x 1	38	CRANKCASE-See Note 4	A-64902-A	x	x	x 1
6	SHOE-clutch	A-55692-A	x	x	x 6		Includes:				
	heavy duty, See Note 1	A-53028	†	†	x 6		GROMMET-(not shown)	64473	x	x	x 2
7	GEAR-drive w/drum					39	BOLT-guide bar	57625	x	x	x 1
	3.57:1 ratio, 21 teeth	A-64286	x	x	x 1	40	PIN-bolt	41738	x	x	x 1
	Includes:					41	BOLT-guide bar	58020-A	x	x	x 1
8	WASHER-thrust	64282	x	x	x 2	42	SEAL	56134	x	x	x 1
	2.84:1 ratio, 25 teeth	A-56515	†	†	x 1	43	STUD	55871	x	x	x 6
	2:1 ratio, 32 teeth	A-56158	†	†	x 1	44	SCREW-shoulder	64133-A	x	x	x 1
	heavy duty, See Note 1					45	SCREW-hex, 12-24 x 3/4	80867	x	x	x 9
	3.57:1 ratio, 21 teeth	A-64287	†	†	x 1	46	GASKET-cylinder	56864	x	x	x 1
	Includes:					47	WASHER-lock, 1/4	83009	x	x	x 4
8	WASHER-thrust	64282	†	†	x 2	48	NUT-1/4-28	81065-2	x	x	x 4
	2.84:1 ratio, 25 teeth	A-58259	†	†	x 1	49	PISTON & PIN	A-55279-A	x	x	x 1
	2:1 ratio, 32 teeth	A-58460	†	†	x 1	50	Includes: PISTON RING	55038	x	x	x 2
9	BEARING-drive gear	56133	x	x	x 1	51	RING-retaining	64742	x	x	x 1
10	NUT-lock, 1/2-20	81101	x	x	x 1	52	RING-retaining	55095	x	x	x 1
11	WASHER-sprocket (outer)	56077	x	x	x 1	49	PISTON & PIN	A-57070-A			x 1
12	SPROCKET-See Note 2					50	Includes: PISTON RING	56291			x 2
	1/2" pitch, 8-tooth	55593-3	x	x	x 1	51	RING-retaining	64742			x 1
	9/16" pitch, 7-tooth	74481-1	†	†	x 1	52	RING-retaining	55095			x 1
	7/16" pitch, 8-tooth	63264	†	†	x 1	53	ROD-connecting	A-59483-1	x	x	x 1
	7/16" pitch, 7-tooth	63263	†	†	x 1		Includes:				
13	KEY-sprocket	56076-1A	x	x	x 2	54	SCREW-8-32 x 9/16	80805	x	x	x 2
14	WASHER-sprocket (inner)	56074	x	x	x 1	55	BEARING-needle	59351	x	x	x 1
15	SPACER-sprocket	56071	x	x	x 1	53	ROD-connecting	A-58303-A			x 1
16	SEAL-formica	56072	x	x	x 1		Includes:				
17	BEARING-ball	56219-S	x	x	x 1	54	SCREW-10-32 x 9/16	58095			x 2
18	RING-retaining	28922	x	x	x 1	55	BEARING-needle	59351			x 1
19	GEAR-driven					56	CRANKSHAFT	58895			x 1
	3.57:1 ratio, 75 teeth	A-56824	x	x	x 1		CRANKSHAFT	58896	x		x 1
	2.84:1 ratio, 71 teeth	A-56516	†	†	x 1		CRANKSHAFT	A-58892-B			x 1
	2:1 ratio, 64 teeth	A-56154	†	†	x 1	57	SCREW-bearing retaining	19238-A	x	x	x 2
20	SHAFT-sprocket	56070	x	x	x 1	58	WASHER-lock, (thin)	83061	x	x	x 2
21	SCREW-flat, 12-28 x 3/8	80651	x	x	x 4	59	GASKET-sealing	55048-A	x	x	x 1
22	GASKET-drivecase cover	55053-B	x	x	x 1	60	RING-retaining	56109	x	x	x 1
23	COVER-gear case	A-55226-C4	x	x	x 1	61	BEARING-main	56097-S	x	x	x 1
	Includes:					62	KEY-rotor	75078	x	x	x 1
24	CAP-filler	A-63717-A	x	x	x 1	63	ROLLERS-needle (set of 27)	A-65615	x	x	x 1
	Includes:						ROLLERS-needle (set of 31)	A-64678			x 1
25	GASKET	56607	x	x	x 1	64	GASKET-back plate	55049	x	x	x 1
	VALVE-check (not shown)	63718	x	x	x 1	65	NUT-3/8-16	81089-2	x	x	x 2
26	SCREW-8-32 x 3/8	80548	x	x	x 3	66	WASHER-lock, 3/8	83018	x	x	x 2
27	RING	55098	x	x	x 1		PLATE-adjusting	A-55591	x	x	x 1
28	WINDOW	55099	x	x	x 1	67	Includes: PLATE	55551-2	x	x	x 1
29	WASHER	55100	x	x	x 1	68	NUT-3/8-16	81123	x	x	x 1
30	SPARK PLUG	40190-S	x	x	x 1	69	PIN-adjusting	55552-1	x	x	x 1
	SPARK PLUG	65544-S				70	SCREW-rd., 5/16-18 x 2	80617	x	x	x 1
31	Includes: GASKET	25038	x	x	x 1	71	PLATE-guide bar (outer)	56957-A	x	x	x 1
32	CYLINDER	A-59998		x	x 1	72	PLATE-guide bar (inner)	56956	x	x	x 1
	CYLINDER	A-63258	x		x 1						
	CYLINDER	A-63522-A			x 1						

Note 1 - Measure width of clutch shoe to determine type of clutch assembly in unit; 5/8" shoe requires standard type mating parts, 3/4" shoe requires heavy duty replacement parts.

Note 2 - Check number of teeth before ordering replacement.

Note 3 - NOISE SUPPRESSOR ASSEMBLY #A-56558 available from your HOMELITE Dealer, use in place of #56396 Cap.

Note 4 - See page 4, Note #4.

ACCESSORIES

	Part No.	Qty.
HANDLE HELPER	A-67757	1
Includes: NUT	67760	1
PLUG	67759	2
KNOB	A-67763	1
HEAT DAMPER KIT	A-55900	1
Includes:		
NUT-flex lock, 10-32	81107-2	1
SCREW-pan hd., 10-32 x 3/4	80583	2
SCREW-rd. hd., 10-32 x 2-1/2	80283	1
SCREEN-spark arrestor	65808	1

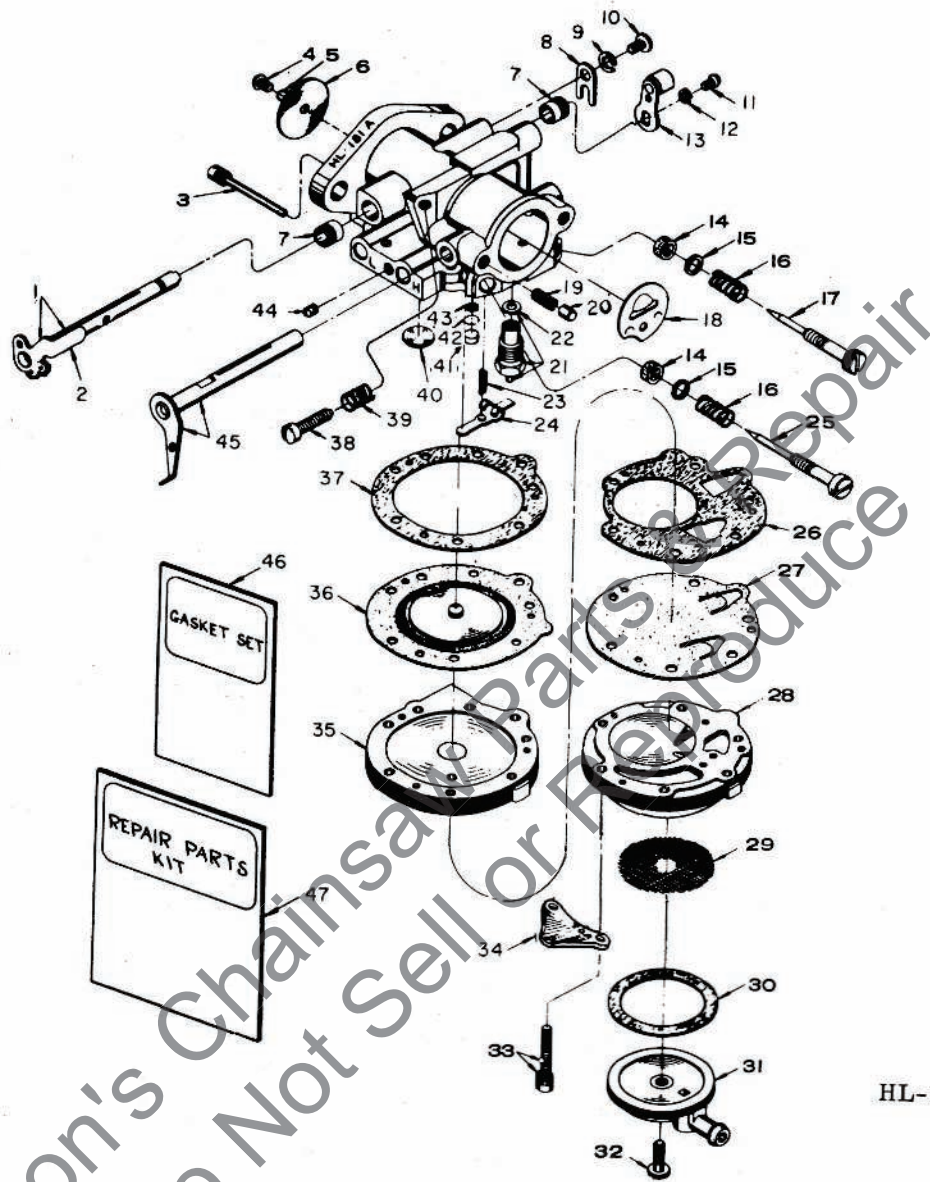

HL-117C (A-58102)

NOTE: Throttle opening spring #75756 is packaged with assembled carburetor. When installing the A-58102 carburetor as replacement on saws without governor, replace friction spring #56175 with throttle opening spring #75756. An anchor pin is provided for this spring.

WIZ 55 • SUPER WIZ 55 • 66 • 80 CHAIN SAWS

No.	Description	Part No.	Qty.
1	THROTTLE SHAFT & LEVER	A-75624-A	1
2	Includes: LEVER-throttle stop	77247-1A	1
3	PIN-fulcrum	† A-55762	1
4	SCREW-rd., 6-32 x 1/4	† 80465	1
5	WASHER-lock, #6	† 83024	1
6	SHUTTER-throttle	75532	1
7	BUSHING	72812	2
8	CLIP-throttle shaft	73086	1
9	WASHER-lock, #8	83000-1	1
10	SCREW-flat, 8-32 x 5/16	73088	1
11	SCREW-rd., 4-36 x 1/4	† 80006-1	1
12	WASHER-lock, #4	† 83008-1	1
13	LEVER-throttle w/roller	A-75528-1	1
14	PACKING-adjusting screw	75733	2
15	WASHER-adjusting screw	75735	2
16	SPRING-adjusting screw	† 73075	2
17	SCREW-main adjustment	† 58021	1
18	SHUTTER-choke	57827	1
19	SPRING	73264	1
20	PLUNGER	71494	1
21	INLET NEEDLE & SEAT	† A-57728	1
22	Includes: GASKET	55844	1
23	SPRING-inlet control lever	† 55759	1
24	LEVER-inlet control	† 55747	1
25	SCREW-idle adjustment	† 56627	1
26	GASKET-fuel pump	58529	1
27	DIAPHRAGM-fuel pump	† 57729	1
28	BODY-fuel pump	55748	1
29	SCREEN-strainer	† 55752	1
30	GASKET-strainer	55751	1
31	COVER-strainer	55750	1
32	SCREW-strainer cover	† 55756	1
33	SCREW-fil, 6-32 x 13/16, w/lockwasher	55316	6
34	BRACKET-spring	63048	1
35	COVER-diaphragm	57923	1
36	DIAPHRAGM-main	† 57829	1
37	GASKET-diaphragm cover	57824	1
38	SCREW-idle stop	71509	1
39	SPRING-idle stop screw	28064	1
40	WELCH PLUG-3/8"	† 30818	1
41	PLUG-channel	† 57820	1
42	RING-retaining	57819	1
43	SCREEN	57818	1
44	SCREW-PLUG-8-32 (early models)	73067	2
	LEAD SHOT (late models)	55746	
45	CHOKE SHAFT & LEVER	A-75740	1
46	GASKET SET	† 57919	1
47	REPAIR PARTS KIT	57987	1
	GASKET & DIAPHRAGM SET	63590	1

† Included in Repair Parts Kit

Part No.	Description	Qty.	Part No.	Description	Qty.	Part No.	Description	Qty.	Part No.	Description	Qty.
19238-A	Screw	2	55805	Line-fuel	1	A-57738	Lead-ground	1	A-65615	Rollers-needle	1
22126	Wrench	1	55871	Stud	6	57744	Box-breaker	1	65808	Screen	1
A-22560	Remover	1	55879	Plate-"On-Off"	1	57749	Screw Group	1	67749	Gasket	1
22726	Pliers	1	55898	Rope-starting	1	57750	Screw Group	1	A-67757	Handle Helper	1
22772	Paint-black	1	A-55900	Damper Kit	1	A-57834-10	Plunger-oil	1	67759	Plug	2
A-22808	Wrench	1	55932-7	Seat-reed valve	1	57991	Gasket-stud	1	67760	Nut	1
22812-1	Plate	1	55933-1	Spacer	1	57993	Gasket-filter	1	A-67763	Knob	1
22820-1	Collar	1	55937	Grip-starting	1	57994	Screw	1	67906	Ring-retaining	1
22828	Pliers	1	55941-1	Reed	4	57996	Stud-mounting	1	68035	Strap-reinforcing	1
23136-2	Body-jackscrew	1	55942	Clamp-reed	4	58020-A	Bolt-guide bar	1	A-68108-1	Shield-cylinder	1
A-23137	Jackscrew	1	55945	Stud	2	58023-A	Cover-clutch	1	68393	Fitting-straight	1
23228	Plug	1	55946	Gasket	1	A-58028	Shoe-clutch	6	A-72475	Fitting-fuel	1
23232	Sleeve	1	A-55954	Rod-throttle	1	58036	Filter-air	1	72107-A	Line-fuel	1
23233	Plug	1	A-55958-4	Valve-reed	1	58095	Screw	2	72174	Gasket	1
23234	Plug	1	55962	Clamp-inner	1	A-58102	Carburetor	1	72970	Spring	1
23267	Anvil	1	55978-2	Gasket-cover	1	A-58165	Points-breaker	1	72971-2	Gasket	1
23391-1	Plug	1	55979	Cover	1	A-58222-3	Governor	1	73730	Stud-fuel tank	1
23475	Paint-red	1	55980	Clip-cover	1	A-58259	Gear-drive w/drum	1	74338	"O" Ring	1
23528	Wrench	1	55982	Nut-terminal	1	A-58303-A	Rod-connecting	1	74481-1	Sprocket	1
A-23696-A	Remover	1	55983	Washer-terminal	1	A-58460	Gear-drive w/drum	1	74917	Fitting-fuel elbow	1
23710	Spanner	1	55984	Wick-felt	1	58517	Insert-grip	1	75078	Key-rotor	1
23742	Decal	1	55986-A	Coil	1	58546-3	Spider-clutch	1	76436	Washer-retaining	1
A-23809	Plug	1	55987	Condenser	1	58547-2	Spider-clutch	1	FASTENING PARTS		
24101	Paint-blue	1	A-56068-A	Muffler	1	58549-A	Brace	1	80097	5/16-18 x 1-1/2	2
24453	Paint-"70" blue	1	56070	Shaft-sprocket	1	A-58892-B	Crankshaft	1	80283	10-32 x 2-1/2	1
25038	Gasket	1	56071	Spacer-sprocket	1	58895	Crankshaft	1	80325-2	1/4-20 x 1/4	1
25527	Ball-check	1	56072	Seal-formica	1	58896	Crankshaft	1	80451	6-32 x 3/8	4
27464	Stud	2	56074	Washer-sprocket	1	58970	Washer-brake	2	80513	6 x 1/2	4
28922	Ring-retaining	1	56076-1A	Key-sprocket	2	59000	Line-oil filter	1	80548	6-32 x 3/8	3
31734	Fitting-elbow	1	56077	Washer-sprocket	1	59022	Spring-valve	1	80560	8-32 x 1/2	4
32814	Plug-button	1	56097-S	Bearing-main	1	59074	"O" Ring	1	80573	1/4-20 x 13/16	6
40190-S	Spark Plug	1	56109	Ring-retaining	1	A-59251	Filter-fuel	1	80575	8-32 x 1/4	3
41738	Pin-bolt	1	56133	Bearing	1	59253-1	Filter	1	80581	1/4-20 x 5/8	4
55019-13	Elbow-air	1	56134	Seal	1	59293	Spring	1	80583	10-32 x 3/4	5
55036	Washer-clutch	1	A-56154	Gear-driven	1	59347	Strap-fuel tank	1	80595	10-24 x 1/2	1
55038	Piston Ring	2	A-56158	Gear-drive	1	59348	Washer-square	1	80598	6-32 x 5/16	2
55045-A	Spring	1	56219-S	Bearing-ball	1	59351	Bearing-needle	1	80617	5/16-18 x 2	1
55048-A	Gasket-scaling	1	56281	Cushion-handle	1	A-59419	Filter-oil	1	80624	10-32 x 1	2
55049	Gasket	1	56282-A	Clamp-handle	1	59450	Seat-check valve	1	80630	6-32 x 1/2	2
55053-B	Gasket	1	56291	Piston Ring	2	A-59455-A	Valve-check	1	80651	12-28 x 3/8	4
55059	Gasket	1	56292-A	Seat-felt	1	A-59483-1	Rod-connecting	1	80658	4-40 x 3/16	8
55066-2	Cap-air filter	1	A-56379	Line-fuel	1	A-59588-1	Shield-cylinder	1	80660	10-24 x 7/8	2
55095	Ring-retaining	1	56396	Cap-muffler	1	A-59998	Cylinder	1	80672	10-24 x 1/2	2
55098	Ring	1	56441-1	Cup-starter	1	60929	Grommet	1	80676	12-24 x 5/8	4
55099	Window	1	56442	Screen-air	1	63024	Sleeve-rod	1	80681-3	1/4-20 x 1/2	4
55100	"O" Ring	1	A-56450-2A	Cover-starter	1	63031	Spring-compression	2	80751	12-24 x 11/16	2
55103-1	Bumper-spiked	1	56451-1	Spring-rewind	1	A-63046	Rod-governor	1	80805	8-32 x 9/16	2
55104-9	Shield-carb.	1	56452	Pulley-starter	1	63047	Spring-governor	1	80821	12-24 x 1/2	4
55107	Gasket	1	56455	Spring-brake	1	63048	Bracket-spring	1	80825	10-32 x 9/16	8
55110	Gasket-seat	1	A-56515	Gear-drive	1	63148-1	Bracket-strap	1	80837	12-24 x 3/8	2
55116	Gasket	1	A-56516	Gear-driven	1	A-63178	Handle	1	80841	10-32 x 1-3/16	2
55123-C	Spring-clutch	2	56531-6	Ring-starter mtg.	1	A-63179	Plate-back	1	80867	12-24 x 3/4	9
55126-A	Cover-clutch	1	56607	Gasket	1	63181-1	Bracket-strap	1	80869-1	10-24 x 3/8	1
55146	Cushion-handle	1	A-56613-A	Muffler-w/cap	1	A-63258	Cylinder	1	80899	12-24 x 9/16	2
55161	Clamp-outer	1	A-56824	Gear-driven	1	63263	Sprocket	1	81013-1	Nut-1/4-20	2
A-55167	Cap-check valve	1	56864	Gasket	1	63264	Sprocket	1	81065-2	Nut-1/4-28	4
A-55191	Line-oil	1	56956	Plate-inner	1	A-63522-A	Cylinder	1	81089-2	Nut-3/8-16	2
A-55207	Trigger	1	56957-A	Plate-outer	1	63577	Rod-throttle	1	81101	Nut-lock, 1/2-20	1
A-55228	Cover-handle	1	A-57070-A	Piston & Pin	1	63578	Spring-throttle	1	81107-2	Nut-10-32	1
A-55226-C4	Cover	1	57172-B	Filter-air	1	63579	Pin-spring	1	81108	Nut-1/4-20	1
55235-A	Lead	1	57173	Gasket-filter	1	A-63717-A	Cap-filler	1	81110	Nut-7/16-20	1
A-55279-A	Piston & Pin	1	57289-1	Button	1	63718	Valve-check	1	81114	Nut-1/4-28	3
A-55282	Lock-throttle	1	57533	Bearing-needle	1	64133-A	Screw-shoulder	1	81123	Nut-3/8-16	1
55290	Sleeve	1	A-57542-5	Housing-fan	1	A-64140-1	Cap-fuel	1	81163	Nut-1/4-20	1
55291-C	Gear Oil	1	57579-A	Rotor	1	64144	Decal-caution	1	81192	Nut-3/8 x 24	1
55372	Pad-felt	1	57595-3	Cover-fuel tank	1	64282	Washer-thrust	2	82146	8-32 x 5/8	3
A-55373-A	Terminal	1	57595-3A	Cover-fuel tank	1	A-64286	Gear-drive w/drum	1	82156	8-32 x 3/4	1
55506-5	Damper-heat	1	57618-4	Elbow-air	1	A-64287	Gear-drive w/drum	1	82177	8-32 x 5/8	1
55551-2	Plate	1	57625	Bolt-guide bar	1	64473	Grommet	2	82187	8-32 x 1-7/16	7
55552-1	Pin-adj.	1	A-57647	Shoe-friction	1	A-64678	Rollers-needle	1	83003	Washer-5/16	2
55553-3	Gasket	1	57652	Fitting-fuel	1	64742	Ring-retaining	1	83009	Washer-1/4	6
A-55568-2	Tank-fuel	1	57659	Gasket	1	A-64846	Kit-fuel tank bracket	1	83018	Washer -3/8	2
A-55591	Plate-adj.	1	A-57671	Handle Bar	1	A-64901	Kit-fuel tank bracket	1	83019	Washer-7/16	1
55593-3	Sprocket	1	A-57673-2	Handle Bar	1	A-64902-A	Crankcase	1	83046	Washer-#10	3
55680	Line-fuel	1	A-57696-A	Cover-air filter	1	A-65324-A	Tank-fuel	1	83061	Washer-lock	2
A-55692-A	Shoe-clutch	6	A-57716	Switch-toggle	1	65358	Gasket	1	84055	Washer-7/16	1
A-55800-A	Valve-reed	1	57733	Tab-ground lead	1	65544-S	Spark Plug	1			

Leon's Chainsaw Parts & Repair
Do Not Sell or Reproduce

Leon's Chainsaw Parts & Repair
Do Not Sell or Reproduce

HOMELITE®

A **textron**
DIVISION

PORT CHESTER, N.Y. U.S.A.