

# HOMELITE

## CHAIN

## SAW



**SUPER**  
**77**

**PARTS LIST**

Leon's Chainsaw Parts & Repair  
Do Not Sell or Reproduce



# HOMELITE SUPER 77 CHAIN SAW

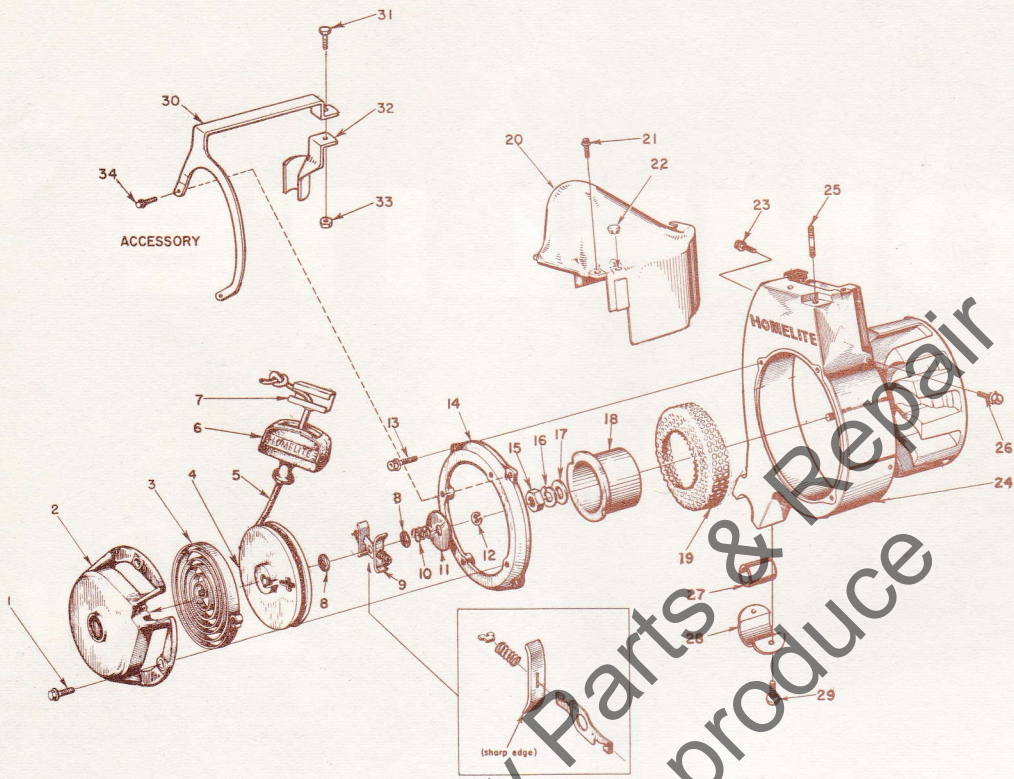

FIGURE 1

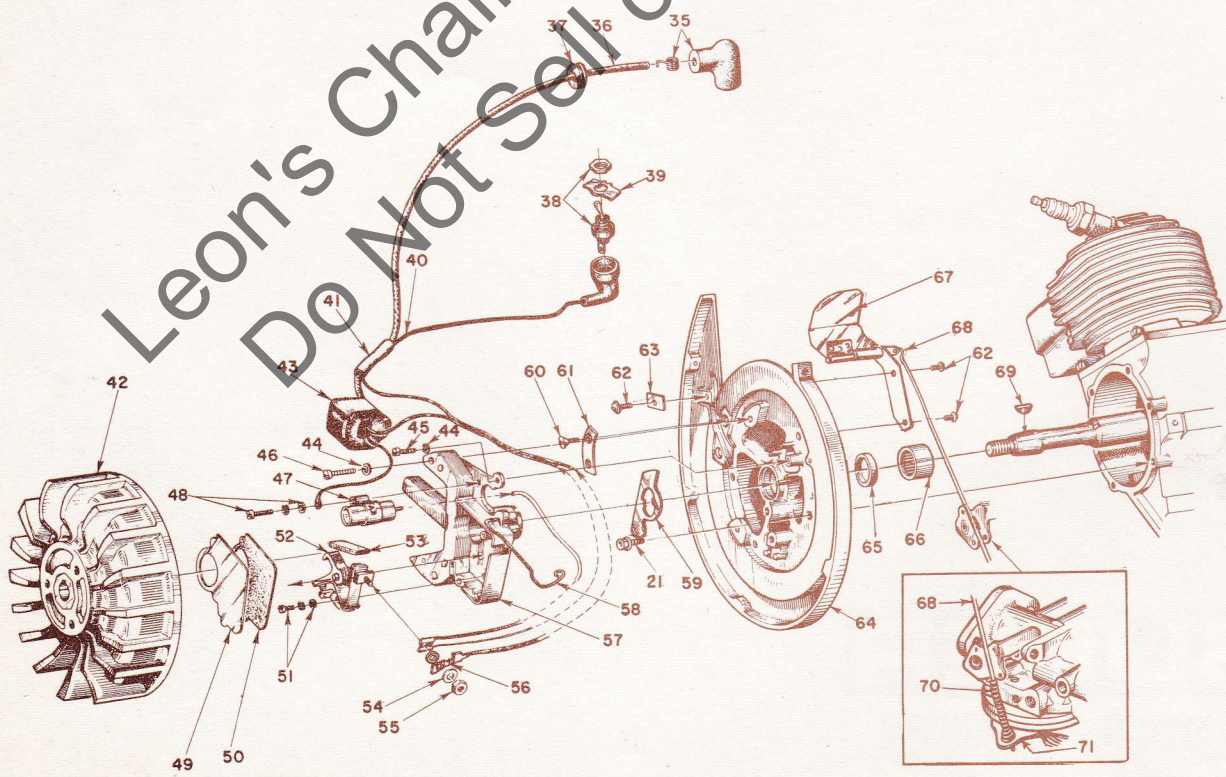

FIGURE 2

ALWAYS FURNISH SAW MODEL AND SERIAL NUMBER WHEN ORDERING PARTS.



# HOMELITE SUPER 77 CHAIN SAW

No.	Description	Part No.	Qty.	No.	Description	Part No.	Qty.
1	SCREW - hex, 1/4 - 20 x 1/2	80681	4	36	LEAD - high tension	55235-A	1
2	COVER - starter	A-56450-2A	1	37	GROMMET	60929	1
3	SPRING - rewind	56451-1	1	38	SWITCH - toggle	A-57716	1
4	PULLEY - starter	56452	1	39	Includes: PLATE - "ON-OFF"	55879	1
5	ROPE - starting	55898	1	40	LEAD - ground	A-57738	1
6	GRIP - rope	55937	1	41	SLEEVE - insulating	55290	1
7	INSERT - grip	58517	1	42	ROTOR	57579-A	1
8	WASHER - brake	58970	2	43	COIL	55986-A	1
9	SHOE - friction	A-57647	1	44	WASHER - lock, #10	83046	3
10	SPRING - brake	56455	1	45	SCREW - fil., 10 - 24 x 1/4	80595	1
11	WASHER - retaining	76436	1	46	SCREW - fil., 10 - 24 x 7/8	80660	2
12	RING - retaining	90618	1	47	CONDENSER w/terminal	55987	1
13	SCREW - hex, 12 - 24 x 9/16	80899	2	48	SCREW GROUP - condenser	57750	1
14	RING - starter	56531-2	1	49	COVER - breaker box	55979	1
15	NUT - jam, 7/16 - 20	81110	1	50	GASKET - cover	55978-2	1
16	WASHER - lock, 7/16	83019	1	51	SCREW GROUP - point	57749	1
17	WASHER - flat, 7/16	84055	1	52	POINTS - breaker (set)	A-58165	1
18	CUP - starter	56441-1	1	53	Includes: WICK - felt	55984	1
19	SCREEN - air	56442	1	54	WASHER - terminal	55983	1
20	SHIELD - cylinder	A-59588	1	55	NUT - terminal	55982	1
21	SCREW - hex, 10 - 32 x 9/16	80825	8	56	TAB - ground lead	57733	1
22	PLUG - button	32814	1	57	BOX - breaker w/core	57744	1
23	SCREW - hex, 12 - 24 x 3/8	80837	2	58	CLIP - cover	55980	1
24	HOUSING - fan	A-57542-2	1	59	SEAL - felt	56292-A	1
25	STUD - fuel tank	73730	1	60	SCREW - flat, 6 - 32 x 5/16	80598	2
26	SCREW - hex, 10 - 24 x 3/8	80869-1	1	61	CLAMP - inner	55962	1
27	CUSHION - handle	56281	1	62	SCREW - pan, 8 - 32 x 1/4	80575	3
28	CLAMP - handle, fan housing	56282-A	1	63	CLAMP - outer	55161	1
29	SCREW - hex, 12 - 24 x 1/2	80821	2	64	PLATE - back	A-63179	1
30	KIT - fuel tank bracket	*A-63143	1	65	Includes: SEAL	56134	1
	Includes:			66	BEARING - needle	57533	1
31	SCREW - hex, 1/4 - 20 x 13/16	80573	1	67	GOVERNOR	A-58222-3	1
32	BRACKET - strap	63148-1	1	68	RQD - governor	A-63046	1
33	NUT - lock, 1/4 - 20	81108	1	69	KEY - rotor	75078	1
34	SCREW - hex, 12 - 24 x 1/4	80751	2	70	SPRING - governor	63047	1
35	TERMINAL - spark plug	A-55378-A	1	71	BRACKET - governor spring	63048	1

AVAILABLE: Complete STARTER ASSEMBLY #A-56540-6, includes index #2 thru #12, #18 and #19.

\*ACCESSORY - See your Homelite Dealer.

## TOOLS

Part No.	Description	Part No.	Description
A-22808	COMBINATION WRENCH	23233	PLUG - back plate, crankcase seal
AA-22560	REMOVER - rotor	23228	PLUG - sprocket shaft bearing
A-23696	REMOVER - threaded spider	22828	PLIERS - piston snap ring
23136	BODY - jackscrew	22726	PLIERS - snap ring
23232	SLEEVE - crankcase seal	22126	WRENCH - socket screw (conn. rod)
22820-1	COLLAR - main bearing	A-23809	PLUG - conn. rod needle bearing
A-23137	JACKSCREW	23267	ANVIL - sprocket shaft
22812-1	PLATE - shaft aligning	23710	SPANNER - starter cup
23391-1	PLUG - back plate needle bearing	23234	PLUG - conn. rod needle bearing

### OIL

#55291-B GEAR OIL - 1 pt.

### PAINT

#23318 SPRAY CAN - blue

### DECAL

#23742 (universal replacement) composed of "DIRECT DRIVE", "GEAR DRIVE", "STARTING INSTRUCTIONS", and two "HOMELITE" (letters 1/4" and 1/2" high).

# HOMELITE SUPER 77 CHAIN SAW

No.	Description	Part No.	Qty.	No.	Description	Part No.	Qty.
1	COVER - air filter	A-57696-A	1	40	SCREW - pan, 10-32 x 1-3/16	80841	2
2	Includes: SCREW	57994	1	41	BUMPER - spiked	55103	1
	(not shown) NUT - retainer	81163	1	42	SCREW - hex, 1/4 - 20 x 13/16	80573	5
3	FILTER - air	58036	1	43	HANDLE BAR - flushcut	A-57673	1
4	GASKET - filter	57993	1		optional - wrap around	A-57671	1
5	GASKET - stud	57991	1	44	FITTING - elbow	31734	1
6	STUD - mounting	57996	1	45	FITTING - straight	31733-1	1
7	LINE - fuel	55680	1	46	WASHER - lock, 5/16	83003	2
8	FITTING - fuel	57652	1	47	SCREW - hex, 5/16 - 18 x 1 1/2	80087	2
9	LINE - fuel	55805	1	48	STRAP - fuel tank	59347	1
10	FILTER - fuel	A-59251	1	49	GASKET	55116	1
11	Includes: FILTER	59253	1	50	SPACER - reed valve	55933	1
12	TANK - fuel	A-59999-1	1	51	STUD	55945	2
13	CAP - fuel	A-64140	1	52	SCREW - pan, 10-32 x 3/4	80583	3
14	Includes: GASKET	58957	1	53	SEAT	55932	1
15	DECAL - caution	64144	1	54	REED	55941-1	4
16	NUT - 1/4 - 28	81114	4	55	CLAMP - reed	55942	4
17	WASHER - square	59348	2	56	SCREW - pan, 4 - 40 x 3/16	80658	8
18	CAP - oil	A-56580	1	57	WASHER - lock, 1/4	83009	2
19	Includes: GASKET	56607	1	58	NUT - 1/4 - 20	81013-1	2
20	LINE - oil	A-55191	1	59	SLEEVE - rod	63024	1
21	VALVE - check	A-59456-A	1	60	HANDLE - throttle w/pin	A-63178	1
22	FILTER - oil	A-59449	1		Includes: PAD - felt	55372	1
23	LINE - oil filter	59000	1	61	ROD - throttle	A-55954	1
24	GASKET	55110	1	62	Includes: SPRING	55045-A	1
25	SEAT - check valve	59450	1	63	TRIGGER - throttle	AA-55207	1
26	BALL - check	25527	1	64	SCREW - pan, 8 - 32 x 1/2	80560	4
27	SPRING - valve	59022	1	65	COVER - handle	AA-55228	1
28	GASKET	55107	1		Includes: LOCK - throttle	AA-55282	1
29	CAP - check valve	AA-55167	1	66	SPRING	72970	1
30	SPRING	59293	1	67	SCREW - hex, 12 - 24 x 1/2	80821	2
31	PLUNGER - oil	A-57834-10	1	68	SHIELD - carburetor	55104-4A	1
32	Includes: "O" RING	74388	1	69	CARBURETOR - NOTE	A-58102	1
33	"O" RING	59074	1	70	GASKET	55553-3	1
34	BUTTON	57289-1	1	71	BRACKET - governor spring	63048	1
35	GASKET	72971-2	1	72	GASKET	55946	1
36	ELBOW - air	57618-1	1	73	BRACE	58549-A	1
37	GASKET	57659	1	74	CUSHION - handle	55146	1
38	SCREW - hex, 12 - 24 x 5/8	80676	4	75	SCREW - hex, 1/4 - 20 x 5/8	80581	4
39	SPRING - compression	63031	2				

NOTE - Service replacement CARBURETOR #A-58102 (HL-117C) supplied with #56175 friction spring installed, and #75756 throttle opening spring packaged with assembly; use carburetor as supplied, discard #75756 spring.

Use Repair Parts Kit #57987, Gasket Set #57919; refer to #23621 Carburetor Sheet.



# HOMELITE SUPER 77 CHAIN SAW

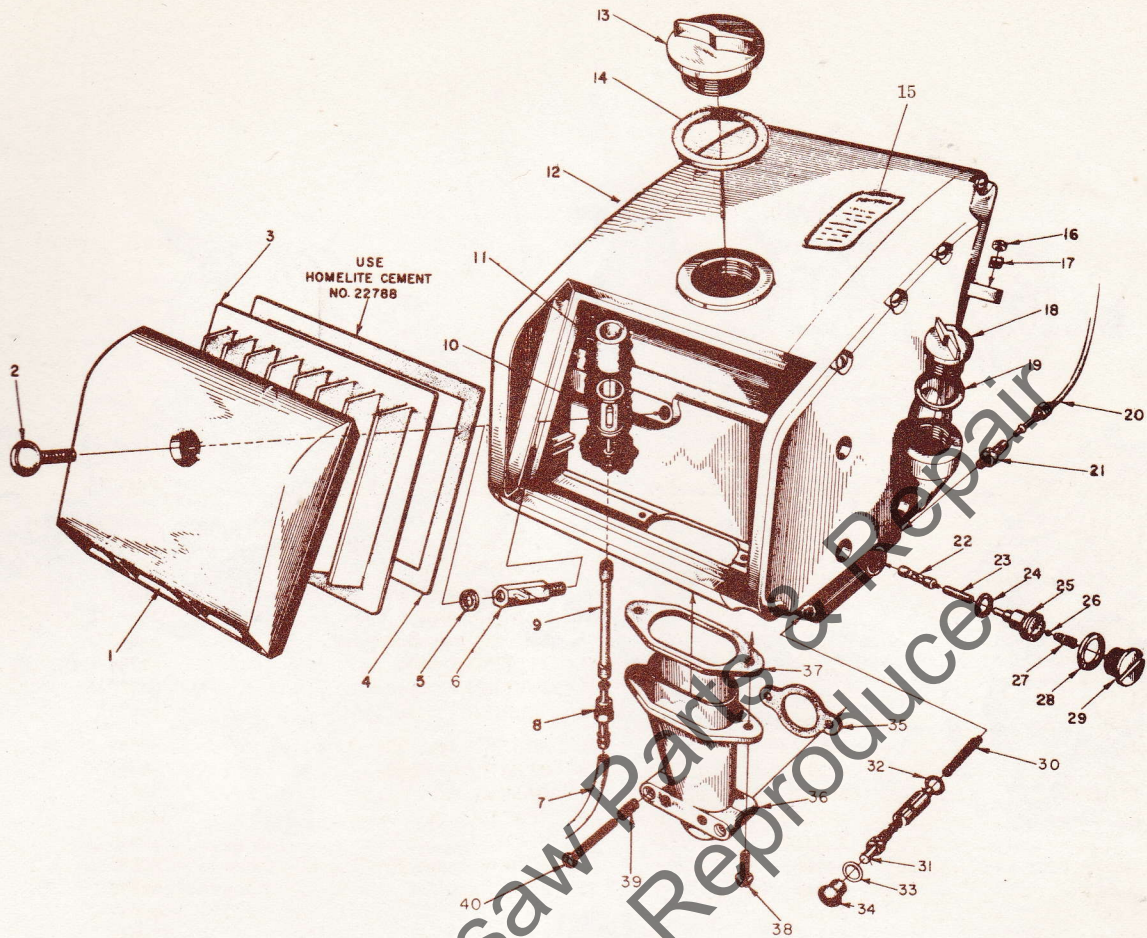

FIGURE 3

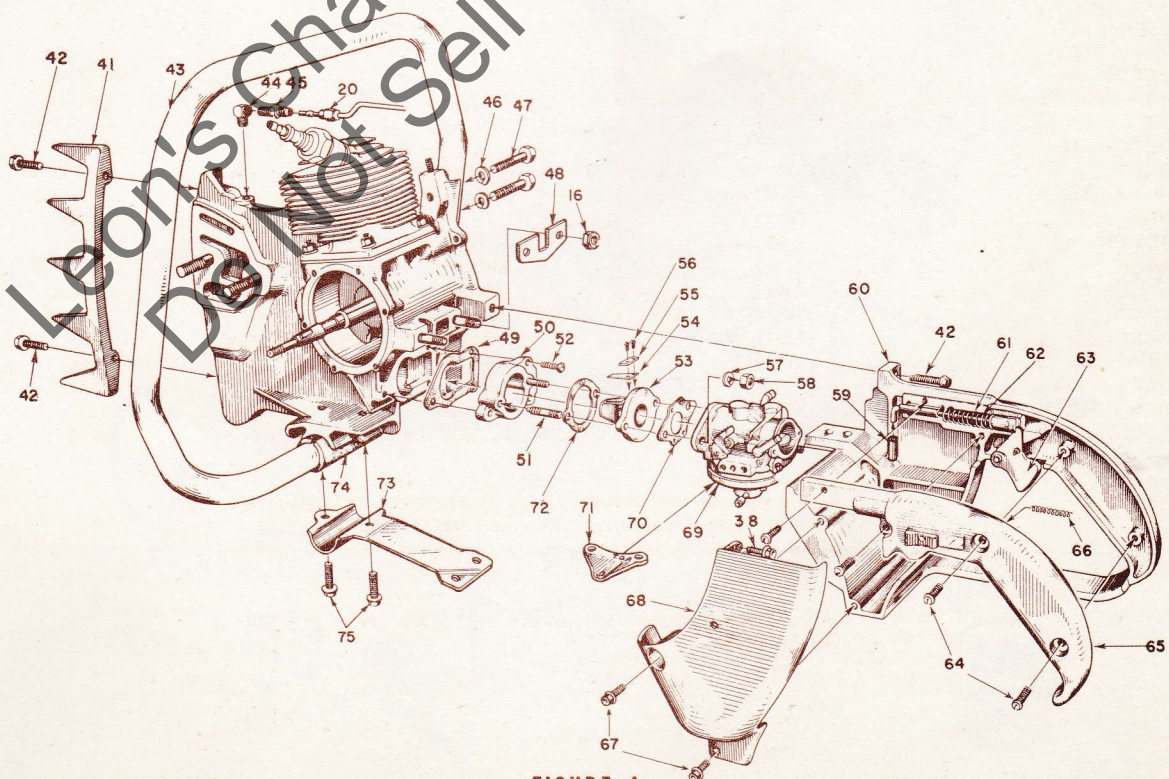

FIGURE 4

ALWAYS FURNISH SAW MODEL AND SERIAL NUMBER WHEN ORDERING PARTS.



# HOMELITE SUPER 77 CHAIN SAW

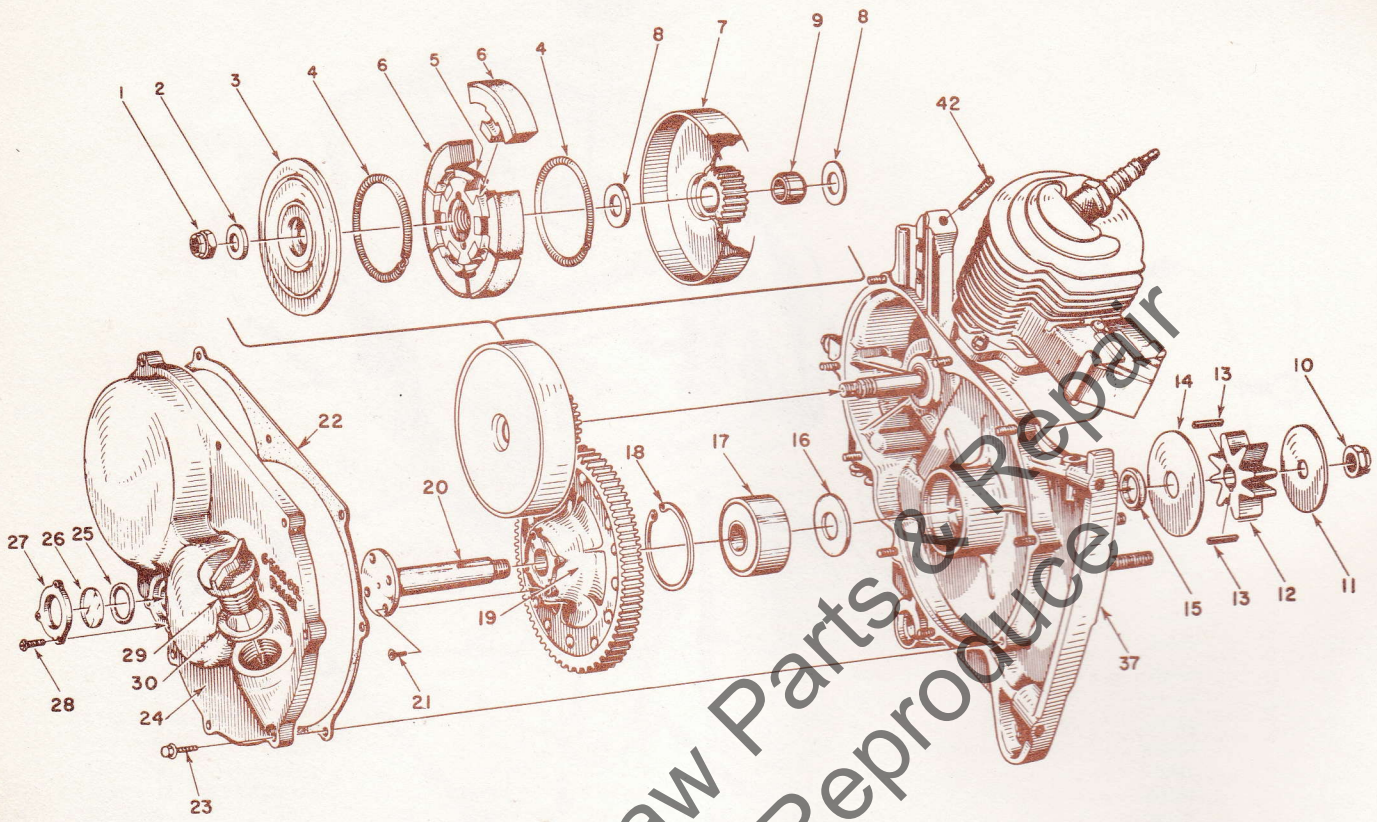
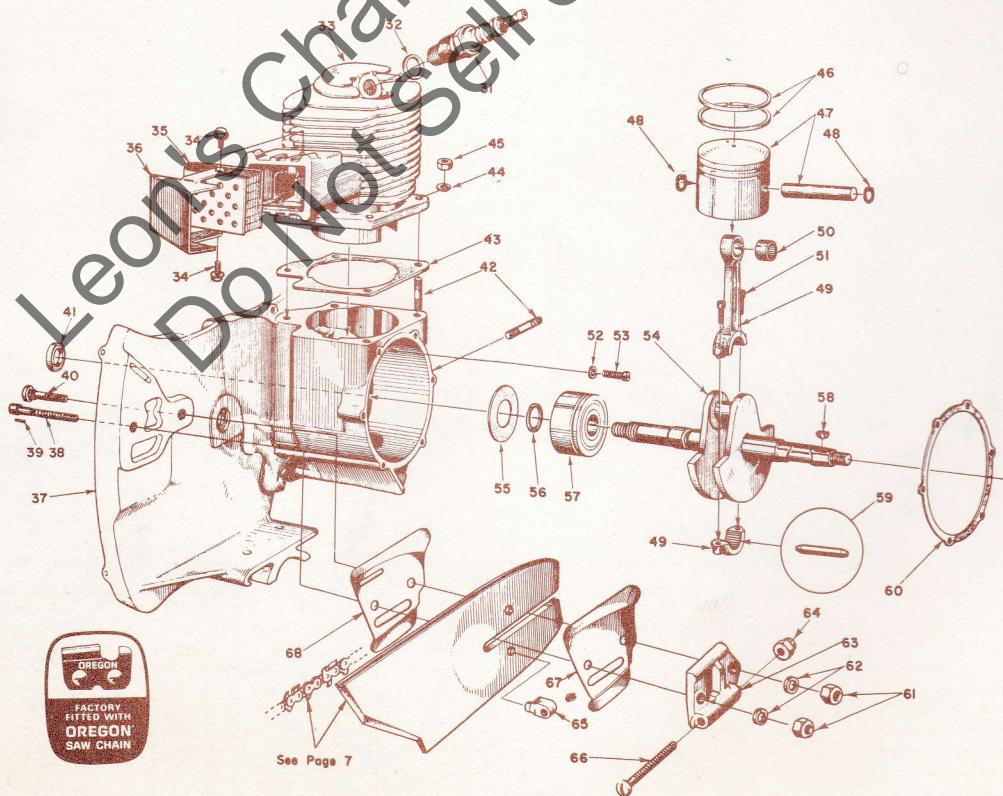

FIGURE 5



See Page 7

FIGURE 6

ALWAYS FURNISH SAW MODEL AND SERIAL NUMBER WHEN ORDERING PARTS.



# HOMELITE SUPER 77 CHAIN SAW

No.	Description	Part No.	Qty.	No.	Description	Part No.	Qty.
1	NUT - 3/8 - 24	81192	1	31	SPARK PLUG	71530-S	1
2	WASHER - clutch	55036	1	32	Includes: GASKET	25038	1
3	COVER - clutch	58023	1	33	CYLINDER	A-63522-A	1
4	SPRING - clutch	55123-C	2	34	SCREW - hex, 10-24 x 3/8	80869-1	2
5	SPIDER - clutch	58547-2	1	35	MUFFLER	A-58068-A	1
6	SHOE - clutch	A-58028	6	36	CAP - muffler, NOTE 2	56396	1
7	GEAR - drive w/drum 3.57:1 ratio, 21 teeth	A-64287	1	37	CRANKCASE	A-63177-A	1
8	Includes: WASHER - thrust	64282	2	38	Includes: BOLT - guide bar	57625	1
	optional 2.84:1 ratio, 25 teeth	A-58259	1	39	PIN - bolt	41738	1
	optional 2:1 ratio, 32 teeth	A-58460	1	40	BOLT - guide bar	58020-A	1
8A	WASHER - thrust	56132	2	41	SEAL	56134	1
9	BEARING - drive gear	56133	1	42	STUD	55871	7
10	NUT - lock, 1/2 - 20	81101	1	43	GASKET - cylinder	56864	1
11	WASHER - sprocket (outer)	56077	1	44	WASHER - lock, 1/4	83009	4
12	SPROCKET - NOTE 1 8 tooth, 1/2" pitch	55593-3	1	45	NUT - 1/4 - 28	81065-2	4
	optional 7 tooth, 9/16" pitch	74481-1	1	46	PISTON RING	56291	2
	optional 8 tooth, 7/16" pitch	63264	1	47	PISTON & PIN	A-57070	1
	optional 7 tooth, 7/16" pitch	63263	1	48	Includes: RING - retaining	55095	1
13	KEY - sprocket	56076-1A	2	49	ROD - connecting	A-58303-A	1
14	WASHER - sprocket (inner)	56074	1	50	Includes: BEARING - needle	59351	1
15	SPACER - sprocket	56071	1	51	SCREW - 10-32 x 9/16	58095	2
16	SEAL - sprocket shaft	56072	1	52	WASHER - lock (thin)	83061	2
17	BEARING - ball	56219-S	1	53	SCREW - bearing retaining	19238-A	2
18	RING - retaining	28922	1	54	CRANKSHAFT	A-58892-B	1
19	GEAR - driven 3.57:1 ratio, 75 teeth	A-56824	1	55	GASKET - sealing	55048-A	1
	optional 2.84:1 ratio, 71 teeth	A-56516	1	56	RING - retaining	56109	1
	optional 2:1 ratio, 64 teeth	A-56154	1	57	BEARING - main	56097-S	1
20	SHAFT - sprocket	56070	1	58	KEY - rotor	75078	1
21	SCREW - flat, 12-28 x 3/8	80651	4	59	ROLLERS (set of 31)	AA-72206	1
22	GASKET - drive case	55053-B	1	60	GASKET - back plate	55049	1
23	SCREW - hex, 12-24 x 3/4	80867	9	61	NUT - 3/8 - 16	81089-2	2
24	COVER - drive case	A-58326-C4	1	62	WASHER - lock, 3/8	83018	2
25	Includes: "O" RING	55100	1	63	PLATE - adjusting	A-55591	1
26	WINDOW	55099	1	64	Includes: PLATE	55551-B	1
27	RING	55098	1	65	NUT	81123	1
28	SCREW - 6-32 x 3/8	80548	3	66	PIN - adjusting	55552	1
29	CAP - filler	A-56580	1	67	SCREW - 5/16 - 18 x 2	80617	1
30	Includes: GASKET	56601	1	68	PLATE - guide bar (outer)	56957-A	1
					PLATE - guide bar (inner)	56956	1

NOTE 1 - Check number of teeth before ordering.

NOTE 2 - NOISE SUPPRESSOR #A-56558 available from your HOMELITE Dealer, use in place of #56396 CAP.

Guide Bars and Chain available at your HOMELITE Dealer, he can help you select the attachments best suited to your needs. For additional listings refer to CATALOG #23630-A, pages #4 and #5, Group 1.

## CHAIN AND BAR CHART

Size	GUIDE BARS (.063 gauge)			CHAIN (.063 gauge)			
	Hard Track Part No.	Roller Nose Part No.	Perma-Hard Tip Part No.	Chipper 1/2" Pitch Part No.	Micro-Bit 1/2" Pitch Part No.	Chipper 9/16" Pitch Part No.	Chipper 7/16" Pitch Part No.
14" - 16"	HT-1416		GW-1416-A	10AC-44E	32C3-44E	4C-39E	62AC3-50E
17" - 19"	HT-1719	RN-1719	GW-1719-A	10AC-51E	32C3-51E	4C-46E	62AC3-58E
21" - 23"		RN-2123	GW-2123-A	10AC-58E	32C3-58E	4C-52E	62AC3-66E
25" - 28"			GW-2528-A	10AC-67E	32C3-67E	4C-60E	62AC3-76E
30" - 33"			GW-3033-A	10AC-77E	32C3-77E	4C-69E	62AC3-88E

ALWAYS FURNISH SAW MODEL AND SERIAL NUMBER WHEN ORDERING PARTS.



# HOMELITE

Leon's Chainsaw Parts & Repair  
Do Not Sell or Reproduce



1166

Printed in United States of America

Part No. 23930

Revision 1

## HOMELITE

A **textron** DIVISION

PORT CHESTER, N. Y.