

PART NUMBER 24685 REV. 1

Printed in U.S.A.

Price .35¢

HOMELITE®

SUPER 1050

SUPER 1130G

AUTOMATIC OILING

CHAIN SAWS



ILLUSTRATED PARTS LIST

HOMELITE **TEXTRON**

Homelite Division of Textron Inc.

SUPER 1050 SUPER 1130G

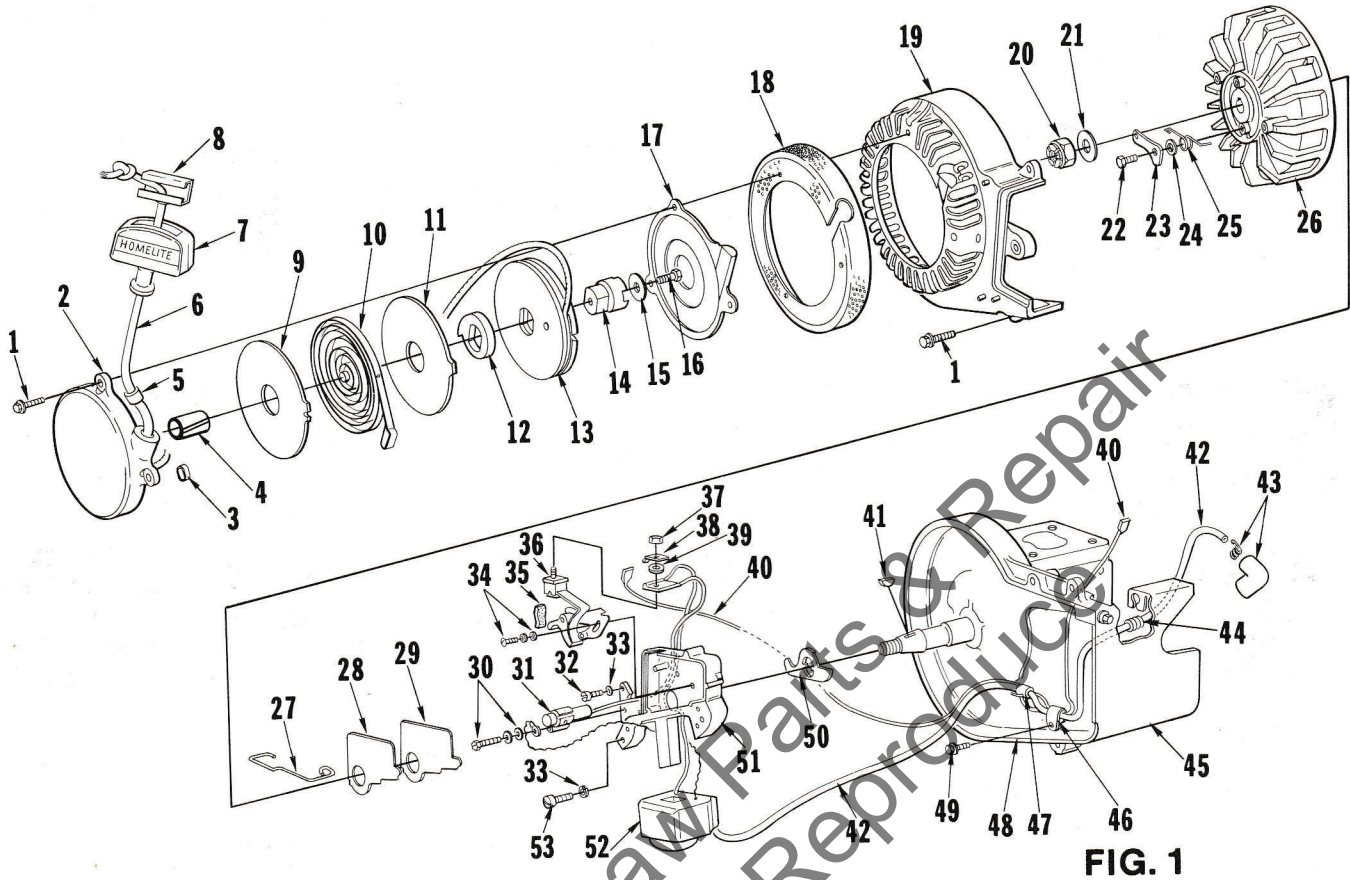

FIG. 1

No.	Description	Part No.	Qty.	No.	Description	Part No.	Qty.
1	SCREW- Hex, 12-24 x 3/4	80867	7	26	ROTOR	64053-A	1
2	COVER- Starter	A-64178-3A	1	27	CLAMP- Breaker box cover	55980	1
	Includes:			28	COVER- Breaker box	55979	1
3	BUSHING- Spring outer loop	65830	1	29	GASKET- Breaker box	55978-2	1
4	BUSHING- Starter post	64443-1	1	30	SCREW GROUP- Condenser	57750	1
5	BUSHING- Starter rope	67177	1	31	CONDENSER- W/terminal	55987	1
6	ROPE- Starter, 48" #5	A-93875	1	32	SCREW- Fil. 10-24 x 1/2	80595	1
	Includes:			33	WASHER- Lock, #10	83046	3
	WASHER- (Not shown)	93862	1	34	SCREW GROUP- Point	57749	1
7	GRIP- Rope	A-69962-A	1	35	POINT SET	A-58165	1
	Includes:				Includes:		
8	INSERT- Rope retaining	70018-A	1	36	WICK	55984	1
9	SHIELD- Spring (inner)	65711	1	37	NUT- Terminal	55982	1
10	SPRING- Rewind	64180-A	1	38	TAB- Ground	57733	1
11	SHIELD- Spring (outer)	65712	1	39	WASHER- Terminal	55983	1
12	LOCK- Rewind spring	64049-B	1	40	LEAD- Ground w/terminals	A-58321	1
13	PULLEY- Starter	64050-1	1	41	KEY- Rotor	75078	1
14	CUP- Starter	67139	1	42	LEAD- High tension	58382	1
15	WASHER- Retaining	58763	1	43	TERMINAL- Spark plug	A-55373-A	1
16	SCREW- Hex, 10-32 x 1/2	80648	1	44	GROMMET	68046	1
17	SHIELD- Sawdust	64052	1	45	SHIELD- Cylinder	A-63736-1	1
18	SCREEN- Fan housing	65390-2	1	46	CLAMP- Lead	56014	1
19	HOUSING- Fan	59094-1	1	47	SLEEVE- Insulating	55290	1
20	NUT- Lock, 7/16-20	81104	1	48	CRANKCASE- W/pin (See Fig. 2)	A-64532	1
21	WASHER- Flat	84047	1	49	SCREW- Hex, 10-32 x 3/8	80869-1	1
22	STUD- Shoulder	64054-B	2	50	SEAL- Breaker box	56292-A	1
23	PAWL- Starter	58756	2	51	BOX- Breaker w/core	57744	1
24	WASHER- Lock, #12	70901	2	52	COIL- W/ground terminal	55986-A	1
25	SPRING- Starter pawl	65375-2	2	53	SCREW- Fil, 10-24 x 7/8	80660	2

SUPER 1050 SUPER 1130G

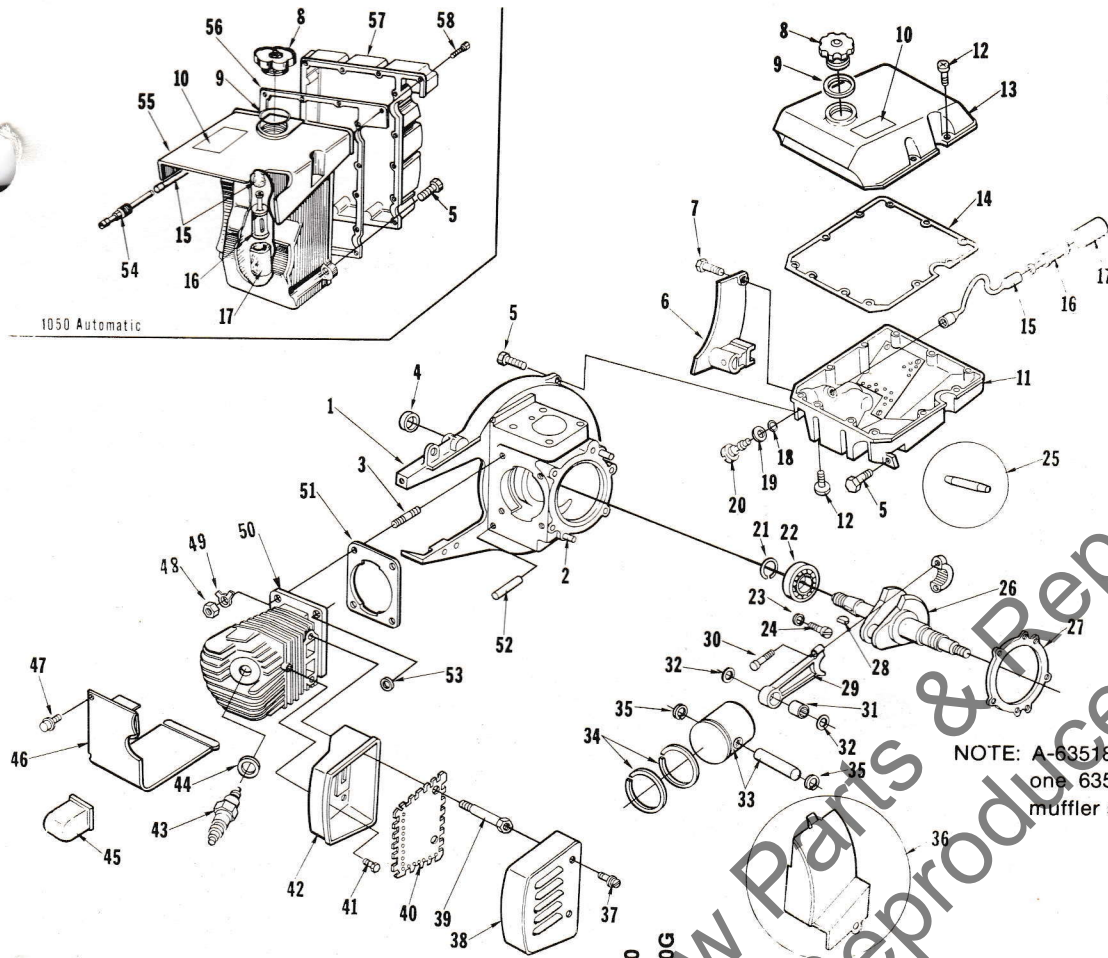

FIG. 2

NOTE: A-63518-1A Spark Arrestor requires one .63548 shim under each muffler stud.

No.	Description	Part No.	\$1050	\$1130G	Qty.	No.	Description	Part No.	\$1050	\$1130G	Qty.
1	CRANKCASE- W/pins Includes:	A-64532	x	x	1	29	CONNECTING ROD Includes:	A-69170	x	x	1
2	PIN- Dowel	74332	x	x	2	30	SCREW- 10-32 x 5/8	80345	x	x	2
3	STUD	72787-1	x	x	4	31	BEARING- Needle	59606	x	x	1
4	SEAL	56308-B	x	x	1	*32	WASHER- Thrust	68719	x	x	2
5	SCREW- Hex, 12-24 x 3/4	80867	x	x	8	*33	PISTON & PIN Includes:	A-69189-A	x	x	1
	SCREW- Hex, 12-24 x 3/4	80867	x	x	4	34	PISTON RING	56291	x	x	2
6	BRACKET- Handle bar	59635-2	x	x	1	35	RING- Retaining	64743	x	x	2
7	SCREW- Hex, 12-24 x 7/8	80891	x	x	1	36	EXCHANGER- Heat (optional)	63103-1	x	x	1
8	CAP- Fuel tank Includes:	A-65741-A	x	x	1	37	SCREW- Hex, 12-24 x 3/8	80837	x	x	2
9	GASKET	65358	x	x	1	38	CAP- Muffler	A-59963-2	x	x	1
	VALVE- Vent (Not shown)	69451	x	x	1		CAP- Muffler	A-64464-2	x	x	1
10	LABEL- Warning	69847	x	x	1	39	STUD- Muffler	59982-B	x	x	2
11	TANK- Fuel W/screen Includes:	A-67739	x	x	1	40	BAFFLE- Muffler	59978-A	x	x	1
12	SCREW- Fil, 8-32 x 5/8	82146	x	x	11		BAFFLE- Muffler	59978-1	x	x	1
13	COVER- Fuel tank	59687-3	x	x	1	41	SCREW- Hex, 1/4-20 x 5/8	80402	x	x	1
14	GASKET- Fuel tank	67677	x	x	1	42	BODY- Muffler	A-59927-2	x	x	1
15	FLEXIBLE LINE	55805	x	x	1	43	SPARK PLUG Includes:	63547-S	x	x	1
16	FILTER ASSEMBLY Includes:	A-59251	x	x	1	44	GASKET	25038	x	x	1
17	FILTER	59253-1	x	x	1	45	CAP- Spark plug	63735-A	x	x	1
18	"O" RING	67900	x	x	1	46	CYLINDER SHIELD	A-63736-1	x	x	1
19	GASKET	63175-1	x	x	1	47	SCREW- Hex, 10-24 x 3/8	80869-1	x	x	2
20	FITTING- Fuel	63132	x	x	1	48	NUT- Hex 5/16-24	25412	x	x	4
21	RING- Retaining	58319-A	x	x	1	49	WASHER- Tab lock	65367-1	x	x	1
22	BEARING- Ball	58190-S	x	x	1	50	CYLINDER Includes:	A-69712-A	x	x	1
23	WASHER- Lock	83061	x	x	2	51	GASKET	64453	x	x	1
24	SCREW- Bearing retaining	19238-3	x	x	2	52	SLEEVE- Insulating	55290	x	x	1
25	ROLLERS- Set of 31	A-69062	x	x	1	53	WASHER- Lock, 5/16	83002	x	x	3
26	CRANKSHAFT CRANKSHAFT	A-64068 A-64351	x	x	1	54	FITTING- Fuel outlet	58364	x	x	1
27	GASKET	63356	x	x	1	55	TANK- fuel	58172-4	x	x	1
28	KEY- Woodruff	75078	x	x	1	56	GASKET- Fuel tank cover	58367	x	x	1
						57	COVER- Fuel tank	59920-2	x	x	1
						58	SCREW- Rd., 6 x 1/2	80513	x	x	5
							ACCESSORIES (Not shown)				
							SPARK ARRESTOR (See Note)	A-63518-1A	x	x	1

* Denotes new parts

ALWAYS FURNISH MODEL AND SERIAL NUMBER
WHEN ORDERING PARTS.

SUPER 1050

FIG. 3

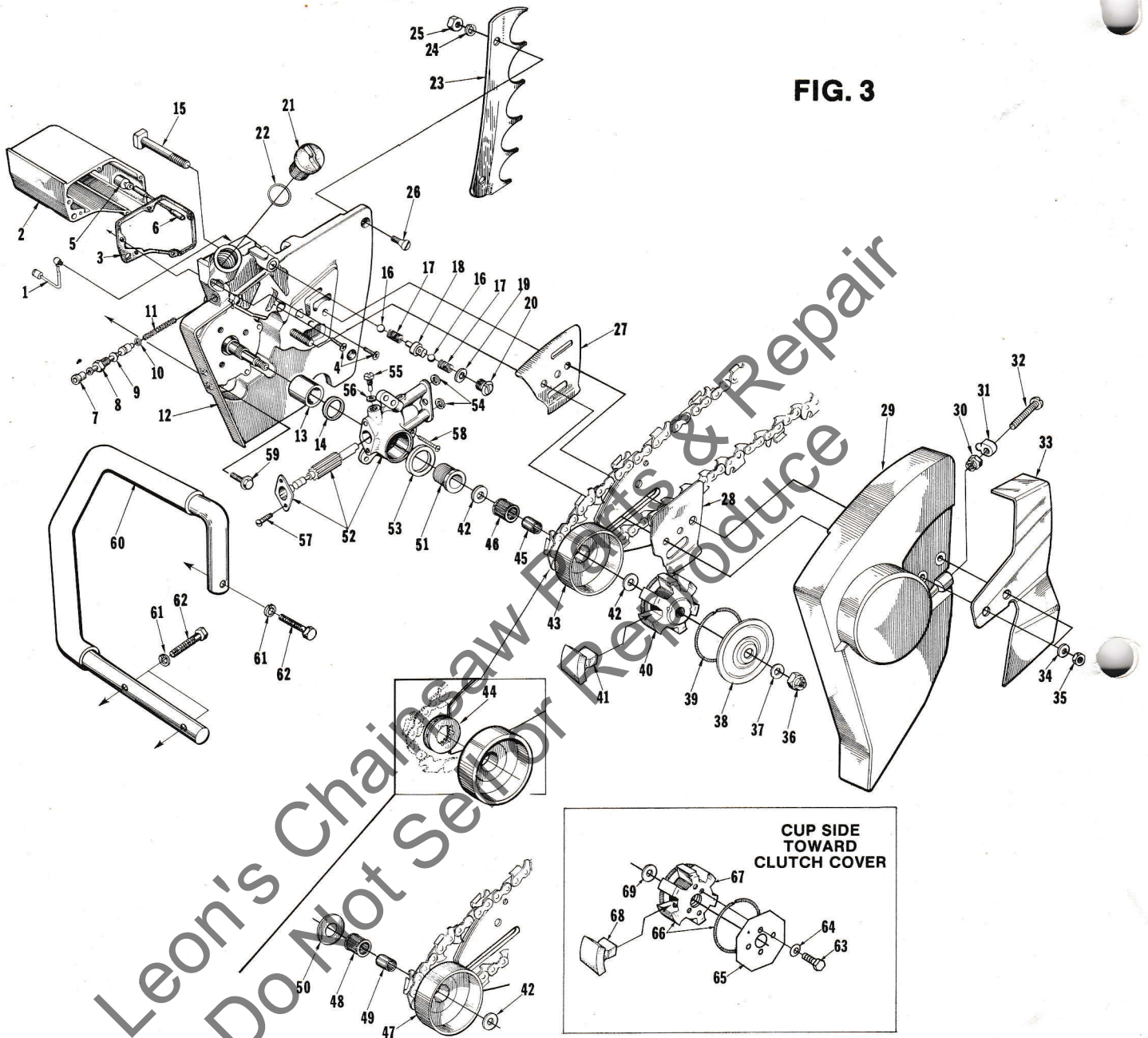

Leon's Chainsaw Parts & Repair
Do Not Sell or Reproduce

SUPER 1050

No.	Description	Part No.	Qty.	No.	Description	Part No.	Qty.
1	LINE- Oil pickup	A-64010	1	39	SPRING- (5/8" clutch)	67441	2
2	RESERVOIR- Oil	A-58341-A	1	40	SPIDER- (5/8" clutch) (Note 1)	58546-2A	1
	Includes:			41	SHOE- Clutch (5/8" clutch)	69754-1B	6
3	GASKET- Reservoir	67122	1	42	WASHER- Thrust (5/8" clutch)	56132	2
4	SCREW- Fil, 8-32 x 3/4	82156	5	43	DRUM & HUB- (Rim type)	A-65991	1
	PIN- Cotter (Not shown)	86301	1		DRUM & HUB	A-68727-A	1
5	FILTER- Oil	A-64293	1	44	SPROCKET- .404 pitch, 8 tooth	65960	1
6	LINE- Oil pickup	59674	1		SPROCKET- 1/2" pitch, 6 tooth	67017	1
7	CONNECTOR- Pump	58337-A	1	45	RACE- Inner	65348	1
8	PLUNGER- Oil pickup	A-57834-10	1	46	BEARING- Needle caged	65393	1
	Includes:			47	SPROCKET & DRUM (open type) (Note 2)		
9	"O" RING- Shaft	59074	1		.404 pitch, 8 tooth	A-57341	1
10	"O" RING- Plunger	74388	1		7/16" pitch, 7 tooth	A-56299	1
11	SPRING- Plunger	59293	1		1/2" pitch, 7 tooth	A-56615	1
12	DRIVECASE	A-64264-B	1		Includes:		
	Includes:			48	BEARING- Needle (Note 2)	56230	1
	TUBE- Oil line (Not shown)	59023	1	49	RACE- Inner (Note 2)	56231	1
13	BEARING- Needle	63043	1	50	WASHER- Thrust (Note 2)	56236	1
14	SEAL	56256-B	1	51	WORM- Gear	63893	1
15	BOLT- Guide bar	58334-A	2	52	PUMP- Automatic oil (short stroke)	A-64073-A	1
16	BALL- Check	25527	2		PUMP- Automatic oil (long stroke)	A-67579	1
17	SPRING	59022	2		Includes:		
18	SEAT- Valve	A-67959	1	53	SEAL- Felt	59926	1
19	GASKET	67123	1	54	"O" RING	59074	2
20	CAP- Check valve	67958	1	55	SCREW- Cam	64102-A	1
21	CAP- Oil	A-63717-C	1	56	GASKET	59736	1
	Includes:			57	SCREW-Pan hd., (4-40 x 1/4)	80919	2
	VALVE- Check (Not shown)	69451	1		PLUG- (Not shown)	59772	1
22	GASKET	56607	1	58	SCREW- Hex, 8-32 x 1/2	80560	3
23	KIT- Spiked bumper (Long spikes)	69275	1	59	SCREW- Hex, 12-24 x 3/4	80867	5
	BUMPER- (Short) (Not shown)	A-58543	1	60	HANDLE BAR- Flush cut	A-69174	1
	Includes:				HANDLE BAR- Wrap around	A-58398-A	1
24	WASHER- Lock, 1/4	83009	2		(Not shown)		
25	NUT- Hex, 1/4-20	81053	2		HANDLE BAR- Wrap around	A-59922	1
26	SCREW- Flat, 1/4-20 x 3/4	80053	2		(Not shown) (Note 3)		
27	PLATE- Guide bar (inner)	67669-A	1		HANDLE BAR- Reversible bow	A-64727	1
28	PLATE- Guide bar (outer)	67670-A	1		(Not shown) (Note 4)		
29	COVER- Drivecase	A-64074-4	1	61	WASHER- Lock, 5/16	83003	3
	Includes:			62	SCREW- Hex, 5/16-18 x 1-1/2	80087	3
30	NUT- 5/16-18	81236	1		KIT- Clutch (Note 1)	A-94744	1
31	PIN- Adjusting	55613-1	1		Includes:		
32	SCREW- 5/16-18 x 2-1/8	82219	1	63	SCREW- (3/4" Clutch)	80361-2	2
33	GUARD- Chain (Note 1)	64029-2	1	64	WASHER- (3/4" Clutch)	12021	1
34	WASHER- Flat, 3/8	84099	2	65	COVER- (3/4" Clutch)	A-24921-A	1
35	NUT- Hex 3/8-16	81089-2	2	66	SPRING- (3/4" Clutch)	93289	2
36	NUT- Hex, 3/8-24 (5/8" clutch)	81192	1	67	SPIDER- (3/4" Clutch)	93288-1	1
37	WASHER- Flat (5/8" clutch)	64027	1	68	SHOE- (3/4" Clutch)	93281-1	6
38	COVER- (5/8" clutch)	56238-A	1	69	WASHER- Thrust (3/4 Clutch)	94743	1

ACCESSORY (NOT SHOWN)

KIT- Drivecase cover (extended)	A-67511	
Includes:		
COVER- Drivecase	67213-2	1
PLATE- Guard	67399-1	1
HANDLE BAR- Wrap around and items #30, 31, and 32	A-69208	1

NOTE 1: 3/4" thickness clutch was used from lot number 8299. 5/8" thickness clutch spider used below lot number 8299 will be discontinued when supply is exhausted. Thereafter, convert to 3/4" thickness clutch with kit, A-94744 which includes items 63 through 69.

NOTE 2: When using open type sprockets index number 47, items 48, 49 and 50 must also be used.

NOTE 3: A-59922 Handle Bar requires a 64029-2 Chain Guard.

NOTE 4: A-64727 Handle Bar requires a 80886 screw.

SUPER 1130G

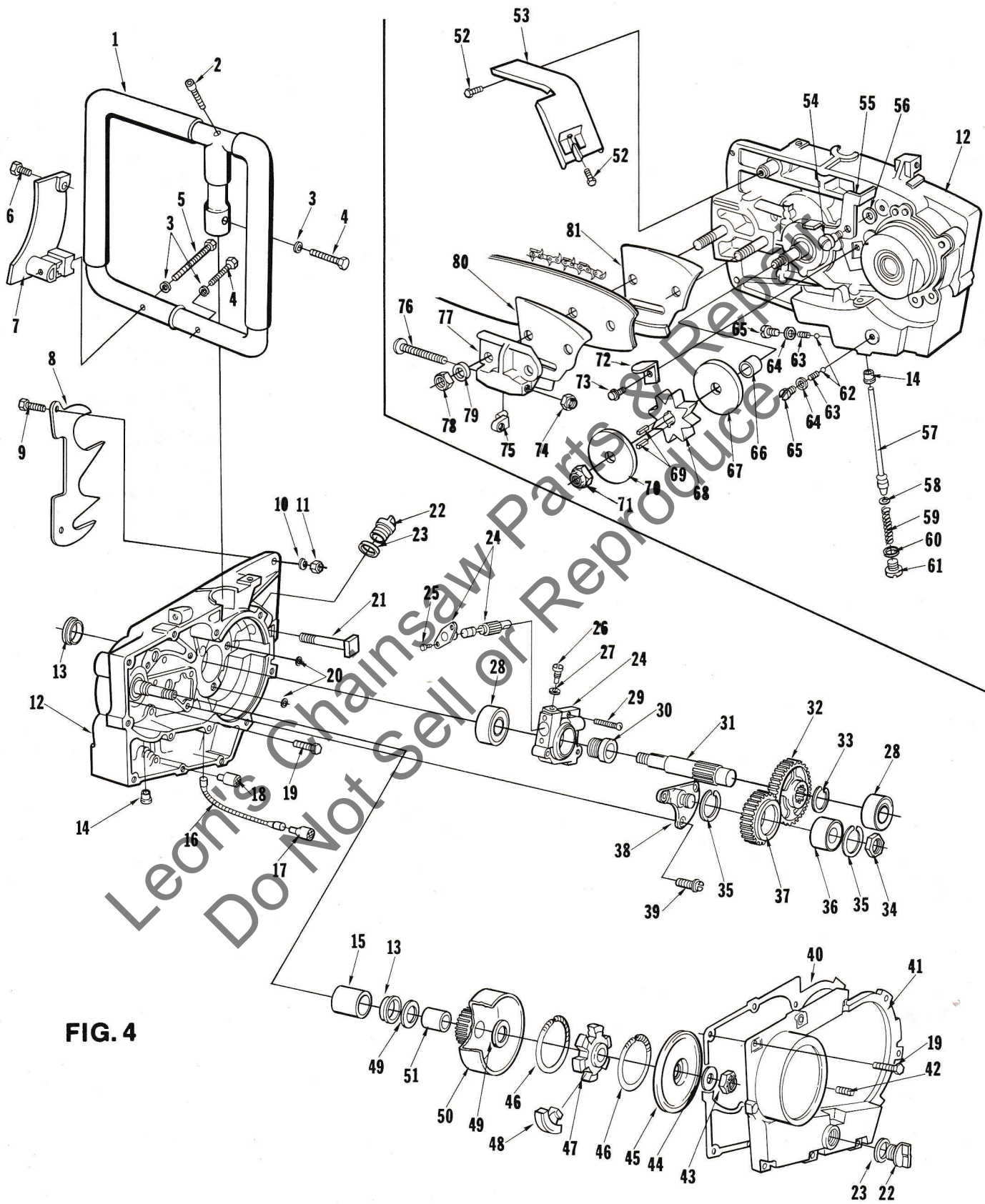

FIG. 4

SUPER 1130G

No.	Description	Part No.	Qty.	No.	Description	Part No.	Qty.
*1	HANDLE BAR	A-69268	1	39	SCREW- Hex, 1/4-20 x 3/4	63407	3
	HANDLE BAR- Wrap around	A-63136	1	40	GASKET	63124	1
	Includes:			41	COVER- Gear housing	59631-4	1
2	SCREW- Soc, 5/16-18 x 1	80308	1	42	PLUG- Pipe	28097	1
3	WASHER- Lock, 5/16	83003	3	43	NUT- Hex, 3/8-24	81192	1
4	SCREW- Hex, 5/16-18 x 1-1/2	80087	2	44	WASHER	55036	1
5	SCREW- Hex, 5/16-18 x 3-1/4	80698	1	45	COVER- Clutch	58023-A	1
6	SCREW- Hex, 12-24 x 7/8	80891	1	46	SPRING- Clutch	67441	2
7	BRACKET- Handle bar	59635-2	1	47	SPIDER- Clutch	58547-3A	1
8	KIT- Spiked bumper (long spikes)	A-63413	1	48	SHOE- Clutch	A-67519	6
	Includes:			49	WASHER- Thrust	56132	2
9	SCREW- Hex, 1/4-20 x 7/8	80181-3	2	50	DRUM- Clutch w/gear	A-63123	1
10	WASHER- Lock, 1/4	83009	2	51	BEARING- Sleeve	56603	1
11	NUT- 1/4-20	81053	2	52	SCREW- Hex, 12-24 x 3/8	80837	3
	KIT- Spiked bumper (Not shown)			53	GUARD- Chain	A-63776	1
	short spikes	A-63138	1		Includes:		
	Includes:				DEFLECTOR- Sawdust (Not shown)	63715	1
	SCREW- Hex, 1/4-20 x 3/4	80218-1	2		RIVET- (Not shown)	85125	3
	WASHER- Lock, 1/4	83009	2	54	SCREW- Pivot	59591	1
	NUT- 1/4-20	81053	2	55	BELL CRANK	59592	1
12	HOUSING- Gear	A-63398-C	1	56	WASHER- Thrust	63109	1
	Includes:			57	PLUNGER- Oil pump	A-63112	1
13	SEAL	56256-B	2		Includes:		
14	BUSHING- Rod	59064	1	58	"O" RING	74388	1
	ELBOW- (Not shown)	59532	1	59	SPRING- Compression	59293	1
15	BEARING	76167-S	1	60	WASHER	58138	1
16	LINE- Oil	59674	1	61	CAP- Oil pump	63115	1
17	FILTER- Oil (automatic)	A-64293	1	62	BALL- Check	25527	2
18	FILTER- Oil (manual)	A-63116	1	63	SPRING- Check valve	59022	2
19	SCREW- Hex, 12-24 x 3/4	80867	17	64	GASKET- Check valve cap	65144	2
20	"O" RING	59074	2	65	CAP- Check valve	65143	2
21	BOLT- Guide bar	58334	2	66	SPACER- Sprocket	59697	1
22	CAP- Filler (oil)	A-63717-C	2	67	WASHER- Sprocket (inner)	56074	1
	Includes per cap:			68	SPROCKET- 1/2" pitch, 8 tooth	55593-3	1
	VALVE- Check (Not shown)	69451	1		SPROCKET- .404 pitch, 8 tooth	70353	1
	GASKET	56607	1	69	KEY- Sprocket	56076-1A	2
24	PUMP- Automatic oil	A-63092	1	70	WASHER- Sprocket (outer)	56077	1
	Includes:			71	NUT- Hex, 1/2-20	81101	1
25	SCREW- Pan, 4-40 x 1/4	80919	2	72	BRACKET- Rod	63110	1
26	SCREW- Cam	64102-A	1	73	SCREW- Hex, 10-24 x 3/8	80869-1	1
27	GASKET	59736	1		PLATE- Adjusting	A-55591	1
28	BEARING- Ball	63107-S	2		Includes:		
29	SCREW- Hex, 8-32 x 7/8	80568	3	74	NUT- Hex lock	81235	1
30	WORM- Gear	63084-A	1	75	PIN- Guide bar adjusting	55552-1	1
31	SHAFT- Sprocket	59277-A	1	76	SCREW- Rd., 5/16-18 x 2-1/8	82219	1
32	GEAR- Driven; 3:1 ratio, 64 teeth	59276-1	1	77	PLATE	55551-2	1
	GEAR- Driven; 2:1 ratio, 42 teeth	59298-1	1	78	NUT- Hex, 3/8-16	81089-2	2
33	RING- Retaining	63108	1	79	WASHER- Lock, 3/8	83018	2
34	NUT- Idler gear	57768-A	1	80	PLATE- Guide bar (outer)	56957-B	2
35	RING- Retaining	28922	2	81	PLATE- Guide bar (inner)	56956-A	1
36	BEARING- Ball	72328-S	1				
37	GEAR- Idler	59250	1				
38	POST- Idler gear	59259-1A	1				

* Denotes new parts

SUPER 1050 SUPER 1130G

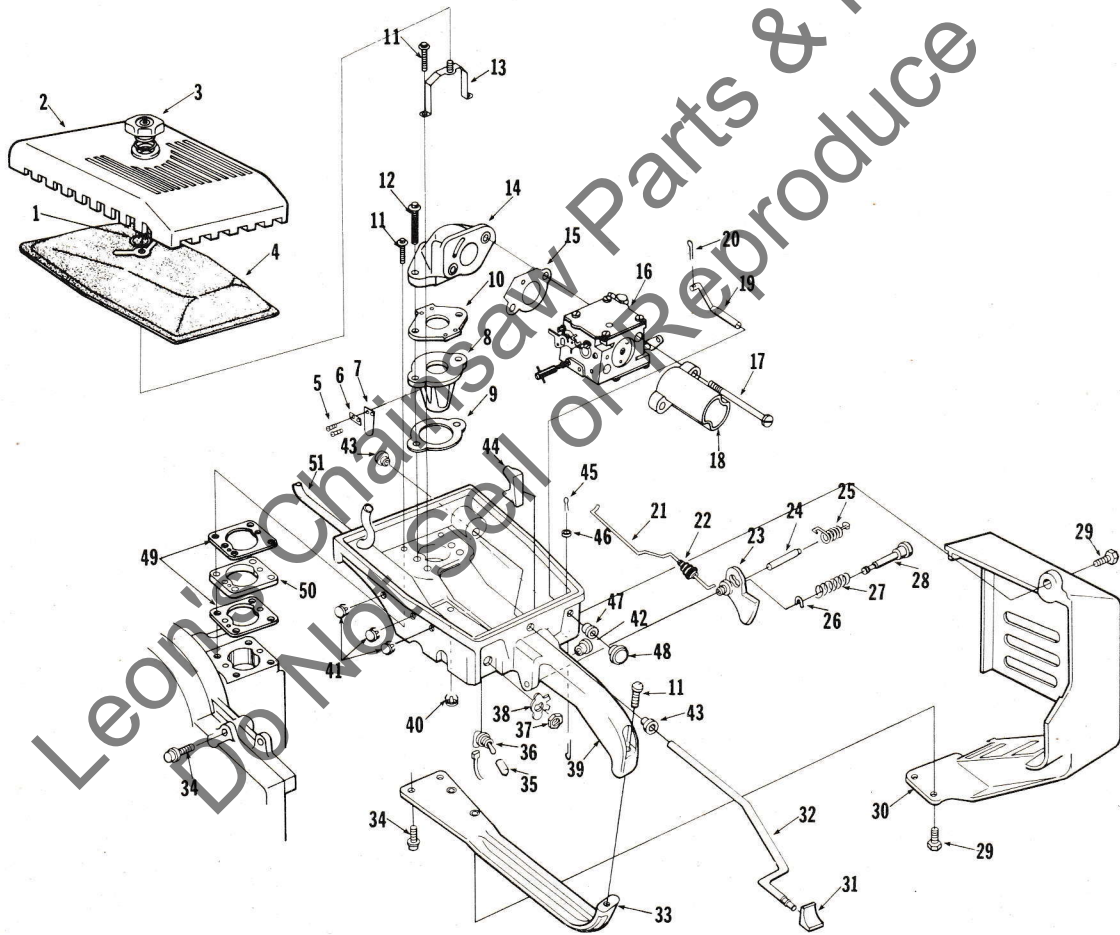
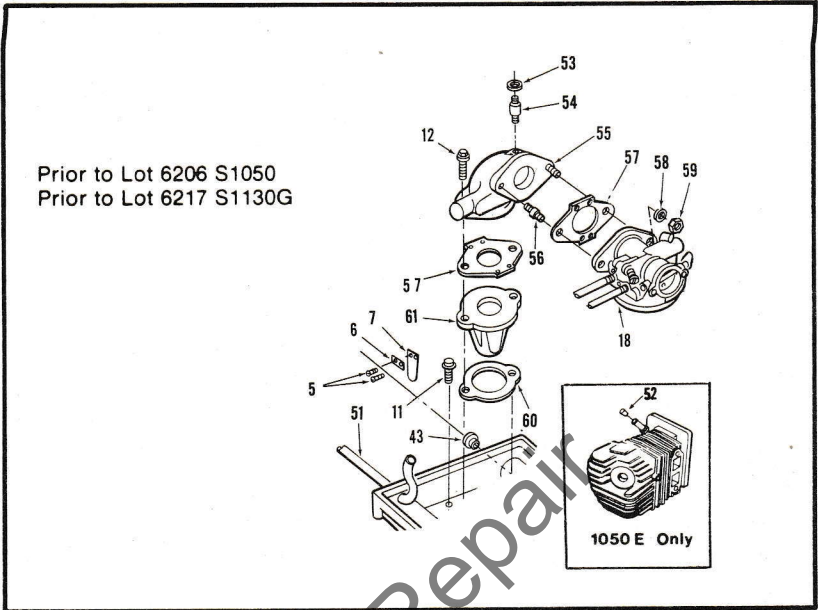

SUPER 1050 SUPER 1130G

No.	Description	Part No.	Qty.	No.	Description	Part No.	Qty.
1	RING- Retaining	58319-A	1	33	BRACE- Throttle handle	58185-A1	1
2	COVER- Air filter	59230-1	1	34	SCREW- Hex hd., 12-24 x 3/4	80867	3
3	NUT- Cover	A-70326	1	35	SLEEVE- Grounding switch	69092	1
4	FILTER ELEMENT- Air	A-69306	1	36	SWITCH- Toggle	A-57650-3A	1
5	SCREW- Pan hd., 4-40 x 3/16	80658	8		Includes:		
6	CLAMP- Reed	59629	4	37	NUT	72084-A1	1
7	REED- Valve	59628	4	38	PLATE- ("RUN-STOP")	70839	1
8	SEAT- Reed valve	59627-2	1	39	HANDLE- Throttle (carb. chamber)	A-63665	1
9	GASKET- Spacer-adapter	55946-1	1		Includes:		
10	GASKET- Carburetor	63655-A	1	40	PLUG- Button w/59765		
11	SCREW- Hex hd., 12-24 x 1	80864	5		"O" Ring	A-69514	1
12	SCREW- Hex hd., 1/4-20 x 1-1/2	80882	2	41	PLUG- Button w/59765		
13	BRACKET & STUD	A-70405	1		"O" Ring	A-64744	3
14	MANIFOLD- Intake	A-70387-1	1	42	BUSHING- Nylon	59064	1
15	GASKET- Carburetor	59722-2	1	43	BUSHING- Nylon	58929	2
16	CARBURETOR (SDC-74)	A-70602-A	1	44	STOP- Oil pump rod	58930	1
17	SCREW- Hex mach., 10-32 x 2.25	80245	2	45	PIN- Cotter	86301	1
18	TUBE- Spitback	70389-1	1	46	FELT	63290	1
19	ROD- Choce (Note 1)	A-70404	1	47	GROMMET	58362	1
20	PIN- Cotter	86324	1	48	BUTTON- Rod	57289-1	1
21	ROD- Throttle (Note 2)	70396	1	49	GASKET- Spacer	58343	2
22	BOOT- Throttle rod	58348	1	50	SPACER	58391	1
23	TRIGGER- Throttle	58161-A	1	51	TUBING- Rubber (fuel line) (Note 3)	70308-24	1
24	SHAFT- Throttle trigger	58353	1	52	PLUG- Cylinder tube (S 1050E only)	70681	1
25	SPRING- Throttle trigger	58352-A	1	53	GASKET- Stud	58392	1
26	RING- Retaining	58409	1	54	STUD- Cover	58361	1
27	SPRING- Throttle latch	58405	1	55	MANIFOLD- Intake	58183-2	1
28	PIN- Throttle latch	58404	1	56	STUD- Carburetor	27464	2
29	SCREW- Hex hd. 12-24 x 5/8	80676	3	57	GASKET- Carburetor	63655-A	2
30	SHIELD- Muffler	63733-2A	1	58	WASHER- Lock 1/4"	83009	2
31	BUTTON- Oil rod	58357	1	59	NUT- Hex, 1/4-20	81013	2
32	ROD- Oil pump (S1050 AO)	58356-B	1	60	GASKET- Spacer adapter	55946	1
	ROD- Oil pump (S1130G)	63127-A	1	61	SEAT- Reed valve	59627-1	1

NOTE 1: Use part #A-58354 prior to lot 6206 on S1050 and lot 6217 on S1130G.

NOTE 2: Use part #59338-A prior to lot 6206 on S1050 and lot 6217 on S1130G.

NOTE 3: Use part #70308-21 prior to lot 6206 on S1050 and lot 6217 on S1130G.

SUPER 1050 SUPER 1130G

CARBURETOR SDC-60 (A-70602) SDC-74 (A-70602-A)

FIG. 6

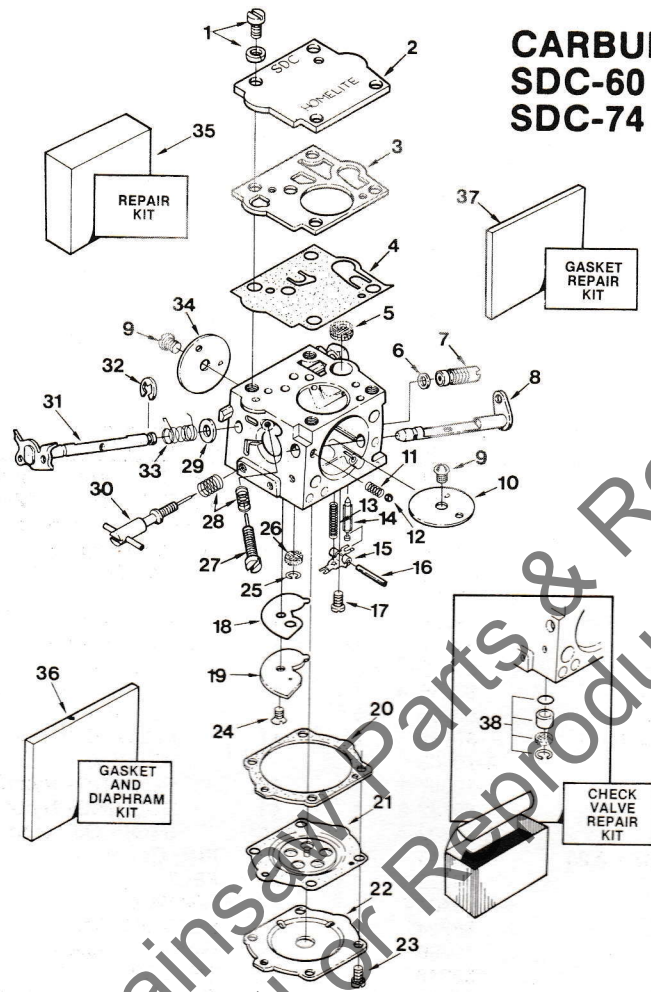

No.	Description	Part No.	Qty.	No.	Description	Part No.	Qty.
1	SCREW- Pump cover	64694	4	25	RING- Screen retaining	67360	1
2	COVER- Fuel pump	67002	1	26	SCREEN- Check valve	67381	1
3	GASKET- Pump	‡67008	1	27	SCREW- Idle adjustment	70674	1
† 4	DIAPHRAGM- Pump	‡64233	1	†28	SPRING- Needle adjustment	64236	2
† 5	SCREEN- Inlet	64243	1	29	WASHER- Nylon	70734	1
6	WASHER- Check valve	70676	1	†30	NEEDLE ASSEMBLY- Idle	70675	1
7	KIT- Governor check valve	93615	1	31	SHAFT ASSEMBLY- Throttle	70669	1
8	SHAFT ASSEMBLY- Choke	67109	1	32	RING- Retaining	70668	1
† 9	SCREW- Valve	64693	2	†33	SPRING- Throttle return	67006	1
10	VALVE- Choke	64228	1	34	VALVE- Throttle	70670	1
†11	SPRING- Choke friction	64238	1	35	KIT- Repair (SDC-60)	70679	1
†12	BALL- Choke friction	60051	1		KIT- Repair (SDC-74)	94877	1
†13	SPRING- Metering lever (SDC-60)	64237	1	36	KIT- Gasket & diaphragm (SDC-60)	93006	1
	SPRING- Metering lever (SDC-74)	70081	1		KIT- Gasket & diaphragm (SDC-74)	94876	1
†14	VALVE- Inlet needle	64229	1	†37	GASKET SET	70678	1
†15	LEVER- Metering	64245	1	38	KIT- Check valve	65386	1
†16	PIN- Metering lever	64244	1		Includes:		
†17	SCREW- Metering lever pin	64688	1		VALVE- Check		1
18	GASKET- Circuit plate	‡68781	1		SEAT- Valve		1
19	PLATE- Circuit (SDC-60)	70677	1		SCREEN- Check valve (Item 26)	67381	1
	PLATE- Circuit (SDC-74)	94874	1		RING- Screen retaining (Item 25)	67360	1
20	GASKET- Metering	‡64231	1	39	FITTING- Inlet elbow	69365	1
†21	DIAPHRAGM ASSEMBLY- Metering	‡64235	1				
22	COVER- Metering diaphragm	70880	1				
23	SCREW ASSEMBLY	64689	4				
24	SCREW- Circuit plate (SDC-60)	12840	1				
	SCREW- Circuit plate (SDC-74)	70082	1				

† Contents of Repair Kit

‡ Contents of Gasket & Diaphragm Kit

SUPER 1050 SUPER 1130G

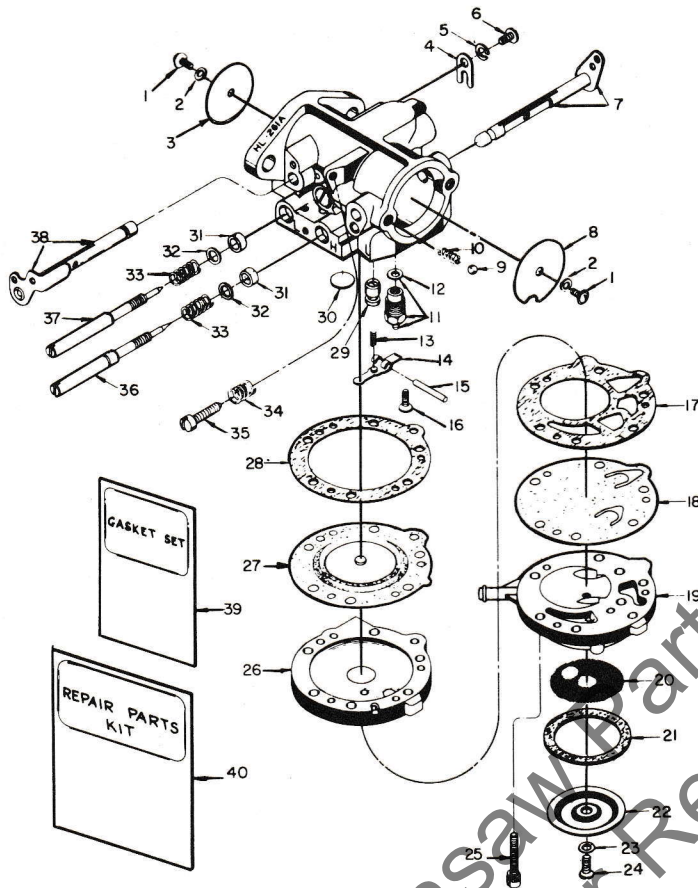

A-69276 HL-294-A

FIG. 7

No.	Description	Part No.	Qty.	No.	Description	Part No.	Qty.
1	SCREW- Rd. hd., 4-40 x 1/4	+80591	2	23	GASKET- Strainer cover screw	28098	1
2	WASHER- Lock	+83008-1	2	24	SCREW- Pump cover	+58525	1
3	SHUTTER- Throttle	64623	1	25	SCREW- Body w/lock washer	55316	6
4	CLIP- Throttle shaft	73086	1	26	COVER- Main diaphragm	A-58533	1
5	WASHER- Lock #8	83000	1	27	DIAPHRAGM- Main control	+57829	1
6	SCREW- Flat hd., 8-32 x 5/16	73088	1	28	GASKET- Cover diaphragm	57824	1
7	SHAFT & LEVER- Choke	A-64627	1	29	NOZZLE- Main	A-77429	1
8	SHUTTER- Choke	64625	1	30	PLUG- Expansion	+30818	1
9	BALL- Check, 5/32" diameter	25527	2	31	PACKING- Adjusting screw	75733	2
10	SPRING- Choke friction	73264	1	32	WASHER- Adjusting screw	75735	2
11	NEEDLE & SEAT	A-64628	1	33	SPRING- Adjusting needle	+73075	2
12	GASKET- Inlet seat	55344	1	34	SPRING- Throttle stop	+28064	1
13	SPRING- Control lever	+65603	1	35	SCREW- Idle stop	+71509	1
14	LEVER- Inlet control	+55747	1	36	NEEDLE- Adjusting (main mixture)	65604	1
15	PIN- Fulcrum	+64622	1	37	VALVE- Needle (idle mixture)	58680	1
16	SCREW- Fulcrum pin retaining	+58992	1	38	SHAFT & LEVER- Throttle	A-64626	1
17	GASKET- Pump diaphragm	58529	1	39	GASKET & PACKING SET	+68657	1
18	DIAPHRAGM-Fuel pump	+57729	1	40	REPAIR PARTS KIT	68663	1
19	BODY- Fuel pump	59265	1		GASKET & DIAPHRAGM SET	63590	
20	SCREEN- Fuel inlet	+58527	1				
21	GASKET- Pump strainer	55751	1				
22	COVER- Strainer	58526	1				

† Indicates contents of Repair Parts Kit

TOOLS

COLLAR- Main bearing install.	22820-2
JACKSCREW- Magneto	A-23672
Includes:	
WASHER (1)	84035
PLATE- Crankshaft aligning	23670
PLATE- Sprocket locking (Super 1130G Auto)	22750
PLIERS- Retaining ring (piston)	22828
PLUG- Bearing install. (Super 1130G Auto)	23391-3
PLUG- Bearing install. (Super 1130G Auto)	23228
PLUG- Bearing install. (conn. rod)	23874
PLUG- Bearing and seal install. (Super 1130G Auto)	23913
PLUG- Bearing install., (clutch) (Super 1050 Auto)	23420
PLUG- Bearing install., (drivecase) (Super 1050 Auto)	23876
PLUG- Seal install., (crankcase)	23233-1
PLUG- Seal install.,(gear housing)	23671
PULLER- Magento rotor	A-24028
Includes:	
SCREW (2)	80450
NUT (2)	81208
SLEEVE- Bearing and shaft install.	23136-2
SLEEVE- Seal protecting	23693
WRENCH- Combination	A-23937-B
WRENCH- Socket screw (conn. rod)	23528
WRENCH- Spanner	A-23696-A
Includes:	
PIN (2)	23717-A
SCREWDRIVER	24541
WRENCH SOCKET	68651
WRENCH- Spanner (Super 1050 Auto)	A-93791

ACCESSORIES

DECAL- (universal replacement) composed of "Direct Drive", "Gear Drive", "Starting Instructions" and two "HOMELITE" (letters 1/4" and 1/2" high).	23742-A
HANDLE- Helper (Super 1130G Auto)	A-67757
Includes:	
NUT- Tee (1)	67760
PLUG- Shoulder (2)	67759
KNOB- Helper handle (1)	A-67763
LOCTITE	23488-B
OIL- Gear (1 pt. container) Super 1130G Auto	55291-C
REEL- 250' Starter Rope #5	57084-1

PAINT

PAINT- Black (spray can)	23772
PAINT- Red (spray can)	23475