

HOMELITE®

- ⓐ PARTS LIST
- ⓑ LISTE DE PIÈCES
- ⓒ TEILELISTE
- ⓓ LISTA DE PIEZAS
- ⓔ ELENCO DELLE PARTI

HT17 UT18007
UT18007A
HT21 UT18011



ⓐ Printed in U.S.A.
ⓑ Imprimé aux E.-U.
ⓒ Gedruckt in U.S.A.
ⓓ Impreso en EE.UU.
ⓔ Stampato negli Stati Uniti
P/N 18545

FIGURE 1
FIGURE 1
ABBILDUNG 1
FIGURA 1
FIGURA 1

HT-17
HT-21

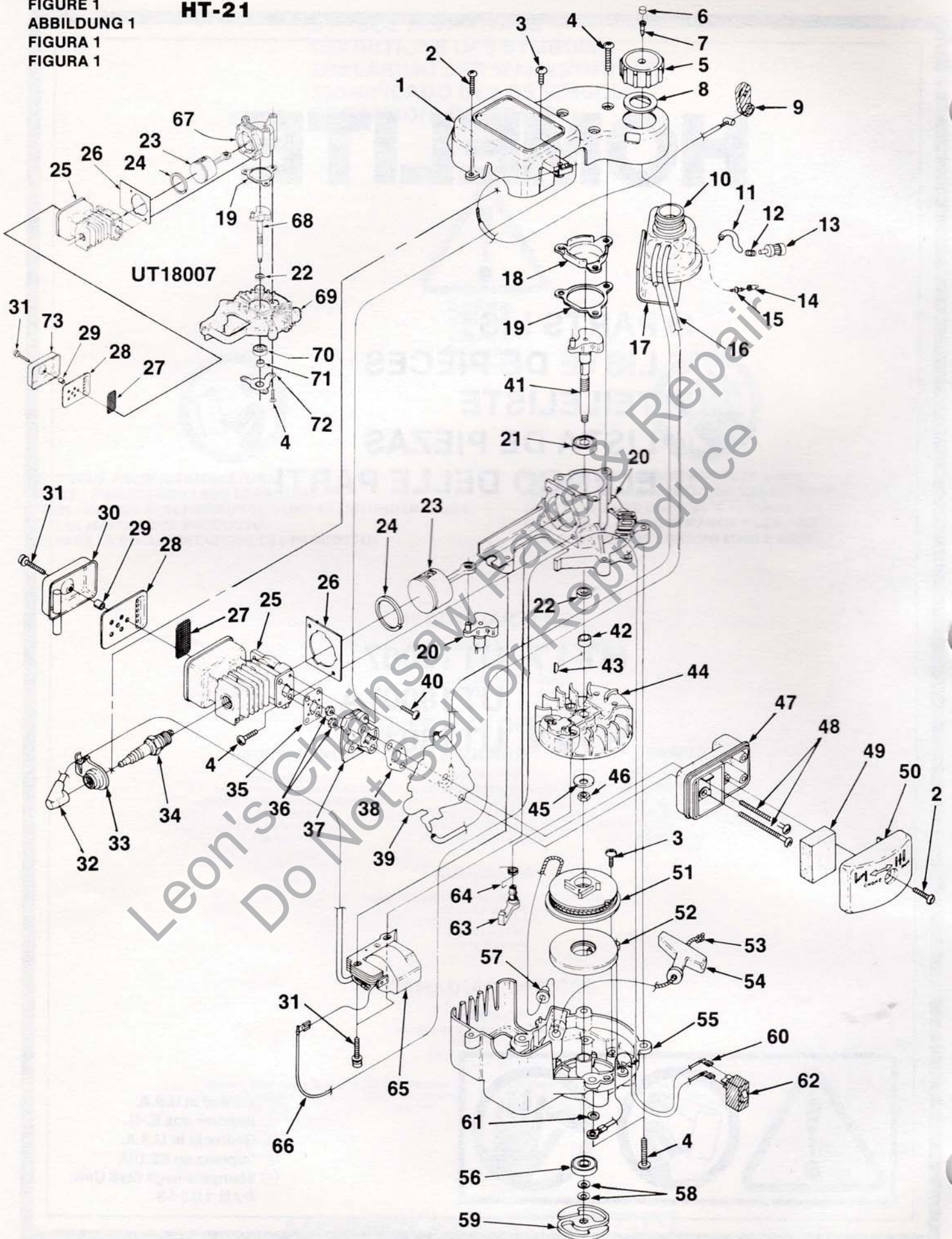

No. No. Nr. No. N°	Part No. No. de pièce Best.—Nr. No. de Pieza Pezzo N°	Description	Qty. Qté. Menge Cant. Qtà.
1	00947	COVER- Crankcase	1
2	82536	SCREW- Plastite (#8 x 3/4")	2
3	82541	SCREW- Plastite (#10 x 1/2")	2
4	82538	Screw- Taptite (10-24 x 3/4")	9
5	● A-00982	CAP- Fuel	1
6	● 98913	FILTER- Cap	1
7	● 98819	VALVE- Filter	1
8	● 98805	GASKET- Fuel cap	1
9	00959	LEVER- Trigger	1
10	● A-01309-A	FUEL TANK ASSY.	1
11	● 94772-14	TUBING- Rubber (3 1/2")	1
12	● 98268	CLAMP- Wire	1
13	● 49422	FILTER- Fuel	1
14	● 98819	VALVE- Filter	1
15	● 01327	FITTING	1
16	● 94772-22	TUBING- Rubber (5 1/4")	1
17	00927-A	SPACER- Fuel tank	1
18	01836	COVER- Crankcase	1
19	00946	GASKET- Crankcase	1
20	● A-02785	CRANKCASE	1
21	● 98797	BEARING- Ball	1
22	● 93858	SEAL- Crankshaft	1
23	● A-01014-A	PISTON & ROD	1
24	● 00915	RING- Piston	3
25	● A-01523-A	CYLINDER MUFFLER ASSY.	1
26	● 00930-B	GASKET- Cylinder	1
27	● 00921	SCREEN- Spark arrestor	1
28	● 00920	BAFFLE- Muffler	1
29	● 00931	SPACER- Muffler	1
30	● A-01838	COVER- Muffler	1
31	● 82540	SCREW- Taptite (8-32 x 1")	3
32	A-02597	SPARK PLUG BOOT KIT	1
33	01010-A	SHIELD- Spark plug	1
34	96169-S	SPARK PLUG- (DJ7Y)	1
35	00932-A	GASKET- Heat Dam	1
36	81208	NUT- (10-24)	2
37	00917-B	HEAT DAM	1
38	98766-A	GASKET- Carburetor	1

No. No. Nr. No. N°	Part No. No. de pièce Best.—Nr. No. de Pieza Pezzo N°	Description	Qty. Qté. Menge Cant. Qtà.
39	A-00962-A	CARBURETOR (WALBRO)	1
	A-00933-A	CARBURETOR (ZAMA)	1
40	82549	SCREW- Taptite (10-24 x 1")	2
41	00911-2	CRANKSHAFT	1
42	01971	SPACER	1
43	69250	KEY- Woodruff	1
44	00923	ROTOR	1
45	01325	WASHER	1
46	81191	NUT- Hex (7/16-20)	1
47	00918	BOX- Air Filter	1
48	82542	SCREW- (10-24 x 2 1/4")	2
49	00934	FILTER- Air	1
50	00919	COVER- Air filter	1
51	00924	PULLEY- Starter	1
52	A-97908	SPRING & CONTAINER	1
53	00715	ROPE- Starter	1
54	70211	GRIP- Starter rope	1
55	● A-01525-A	HOUSING- Engine & Pulley	1
56	● 98843	BEARING- Ball	1
57	● 96981-1A	BUSHING- Starter	1
58	70788	WASHER- Belleville	2
59	00961-1	CLUTCH- (S)	1
60	A-00943	LEAD- Ground	1
61	84003	WASHER- Flat (#10)	1
62	00941	SWITCH	1
63	00928	PAWL- Starter	1
64	00929	SPRING- Torsion	1
65	94711-BS	MODULE	1
66	A-00942	LEAD- Electrical	1
67	00945	CRANKCASE (UT18007)	1
68	00911-1	CRANKSHAFT (UT18007)	1
69	● A-01524	BACKPLATE (UT18007)	1
70	● 98798	BEARING- Ball (UT18007)	1
71	01012	SPACER (UT18007)	1
72	00957	COVER- Bearing (UT18007)	1
73	00922	COVER- Muffler (UT18007)	1

- ASSEMBLIES
- ENSEMBLES
- BAUSÄTZE
- CONJUNTOS
- COMPLESSI

- * Your original carburetor may be identified as Walbro or Zama. Either replacement type will work with your hedge trimmer.
- * La marque de votre carburateur d'origine peut être soit Walbro, soit Zama. Ces deux types peuvent être utilisés sur votre taille-haies.
- * Ihr Original-Vergaser kann ein Walbro oder Zama sein. Als Ersatzteil für Ihre Heckenschere passen beide Typen.
- * El carburador original puede ser de Walbro o Zama, Ambos tipos do carburador de repuesto funcionarán con su podadora.
- * Il carburatore originale potrebbe essere identificato dalla dicitura Walbro o Zama. Entrambi i tipi di ricambio funzionano con il tosabordo in dotazione.

FIGURE 2
FIGURE 2
ABBILDUNG 2
FIGURA 2
FIGURA 2
HT-17
HT-21

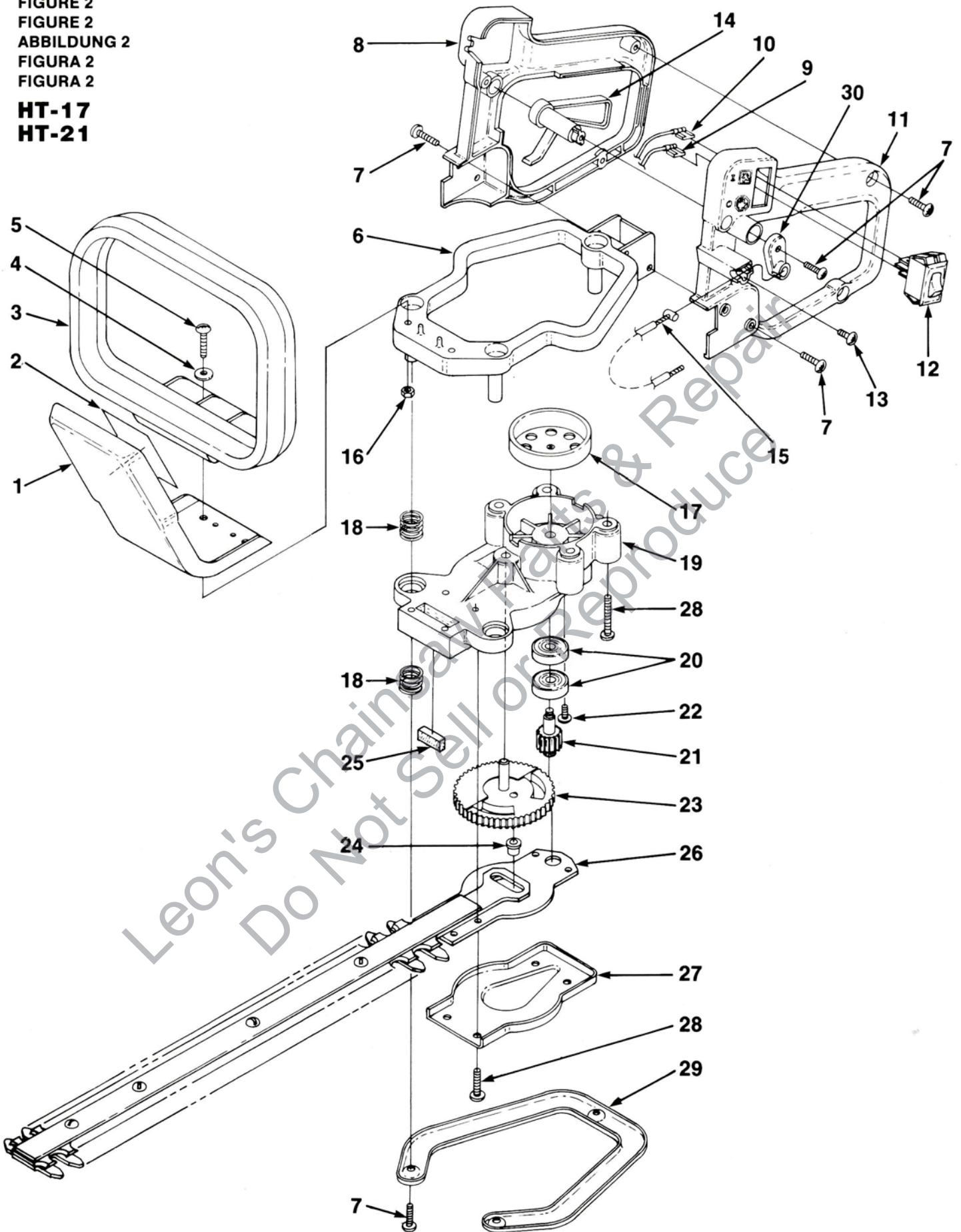

No. No. Nr. No. N°	Part No. No. de pièce Best.—Nr. No. de Pieza Pezzo N°	Description	Qty. Qté. Menge Cant. Qtà.
1	00937	GUARD- Hand (HT17)	1
	01972	GUARD- Hand (HT21)	1
2	01317	DECAL- Caution	1
3	00936-A	HANDLE- Front	1
4	95249	WASHER- Flat (10-24)	2
5	82538	SCREW- Taptite (10-24 x 3/4")	2
6	01007	BASE- Vibration Isolator	1
7	82536	SCREW- Plastite (#8 x 3/4")	11
8	00938	HANDLE- Rear (right)	1
9	A-00942	LEAD- Electrical	1
10	A-00943	LEAD- Ground	1
11	00939	HANDLE- Rear (left)	1
12	00941	SWITCH	1
13	82541	SCREW- Plastite (#10 x 1/2")	2
14	00958	TRIGGER	1
15	00940	CABLE- Throttle	1
16	81208	NUT- (#10-24)	2
17	00949	DRUM- Clutch	1
18	01009	SPRING- Compression	6
19	• A-01526	GEAR BOX ASSY.	1
20	• 98843	BEARING- Ball	2
21	• A-01313	PINION & SCREW ASSY.	1
22	• 82541	SCREW- Plastite (#10 x 1/2")	1
23	• A-01312	GEAR & PIN ASSY.	1
24	• 00955	BUSHING	1
25	• 00935	BLADE SEAL	1
26	A-00956	BLADE ASSY. (HT17)	1
	A-01841	BLADE ASSY. (HT21)	1
27	00954	COVER- Gear box	1
28	82537	SCREW- Plastite (#10 x 7/8")	10
29	01013	BRACE	1
30	00959	LEVER- Trigger	1

- ASSEMBLIES
- ENSEMBLES
- BAUSÄTZE
- CONJUNTOS
- COMPLESSI

FIGURE 3
 FIGURE 3
 ABBILDUNG 3
 FIGURA 3
 FIGURA 3
HT-17
HT-21

CARBURETORS
CARBURATEURS
VERGASER
CARBURADORES
CARBURATORI

When ordering parts, refer to the manufacturer's name (Walbro or Zama) and use the correct Parts List.

Lorsque vous commandez des pièces de rechange, trouvez le nom du fabricant (Walbro ou Zama) et utilisez la liste de pièces de rechange correcte.

Bei der Bestellung von Ersatzteilen bitte den Hersteller (Walbro oder Zama) beachten, und die richtige Ersatzteilliste benutzen.

Al momento di ordinare pezzi di ricambio, fare riferimento al nome del fabbricante (Walbro o Zama) ed usare l'elenco corretto dei pezzi di ricambio.

Al pedir piezas de repuesto, búsqe el nombre del fabricante (Walbro o Zama) y use la lista de piezas de repuesto correspondiente.

WALBRO WT-173
(A-00962-A)

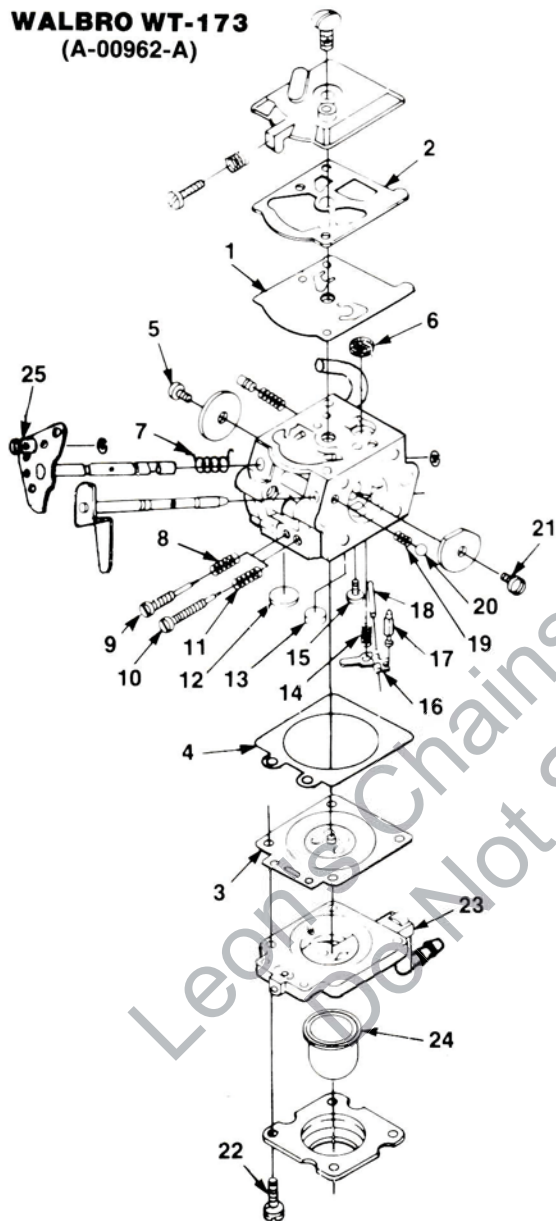

ZAMA CIU-H12A
(A-00933-A)

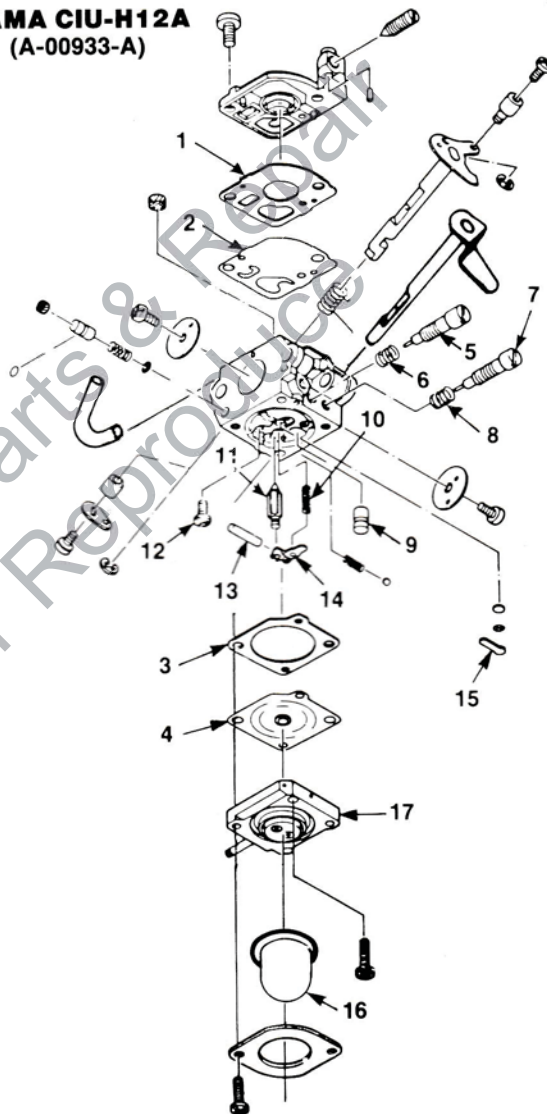

NO.	PART NO.	DESCRIPTION
1-4	A-00285-A	GASKET KIT
1-22	A-02911	REPAIR KIT
23	A-02894	PRIMER BASE KIT
24	01201	PRIMER BULB
25	A-00289	SWIVEL KIT

NO.	PART NO.	DESCRIPTION
1-4	A-01197-A	GASKET/DIAPHRAGM KIT
1-15	A-00288	REPAIR KIT
16	A-01195-A	PRIMER BULB
17	02934	PRIMER BASE KIT (Plastic)*
	01784	PRIMER BASE KIT (Aluminum)*

- * Primer base kits are not interchangeable.
- * Les jeux de base d'amorçage ne sont pas interchangeables.
- * Sockelsätze für die Vorpumpe sind nicht austauschbar.
- * I kit della base del cicchetto non sono intercambiabili.
- * Los juegos de base de cebador no son intercambiables.

NOTES
NOTES
NOTIZEN
NOTAS
NOTE

Leon's Chainsaw Parts & Repair
Do Not Sell or Reproduce

**SYMBOL DEFINITIONS
DEFINITIONS DES SYMBOLES
ERKLÄRUNG DER WARNSYMBOL
SIGNIFICADO DE LOS SIMBOLOS
DEFINIZIONI DEI SIMBOLI**



**DANGER!
DANGER!
GEFAHR!
¡PELIGRO!
PERICOLO!**



**READ YOUR PRODUCT LITERATURE.
LIRE LES PUBLICATIONS SUR LE PRODUIT.
DIE MASCHINEN-BESCHREIBUNGEN UND ANLEITUNGEN LESEN.
LEER EL MANUAL DEL PRODUCTO.
LEGGERE LA DOCUMENTAZIONE DEL PRODOTTO.**



**DANGER- KEEP HANDS AND FEET AWAY.
DANGER- NE PAS APPROCHER LES MAINS NI LES PIEDS.
GEFAHR- HÄNDE UND FÜSSE FERNHALTEN
PELIGRO- ALEJAR LAS MANOS Y LOS PIES.
PERICLO- TENERE LONTANI MANI E PIEDI.**

HEADQUARTERS

**HOMELITE DIVISION OF TEXTRON INC.
P.O. BOX 7047
CHARLOTTE, N.C. 28241**

OVERSEAS OFFICES

NETHERLANDS

**HOMELITE TEXTRON
DIVISION OF TEXTRON ATLANTIC
(HDQS. — Europe, Africa and Middle East)
Haverstraat 24
2153 GB Nieuw Vennepe
The Netherlands**

ENGLAND

**HOMELITE
DIVISION OF TEXTRON LIMITED
UNIT 22
Hither Green Trading Estate
Clevedon (Nr. Bristol)
Avon, BS 21 6XU England**

FRANCE

**HOMELITE TEXTRON
UNE DIVISION DE TEXTRON
S.A.R.L.
Z.I. du Vert-Galant
Rue du Chateau/Rue de la Garenne
95310 Saint-Quen-L'Aumone
France**

AUSTRALIA

**HOMELITE DIVISION OF TEXTRON PACIFIC LIMITED
HEADQUARTERS
22 Terra - Cotta Drive
Blackburn, 3130
Victoria, Australia**

CANADIAN OFFICES

HOMELITE

**DIVISION OF TEXTRON CANADA LIMITED
1850 55th Avenue
Lachine, Quebec, Canada
H8T 3J5**

Unit #10, 3260 Viking Way
Richmond, British Columbia
V6V 1N6

16520-111th Avenue
Edmonton, Alberta
T5M 3V8

595 Canarctic Drive
Downsview (Toronto)
Ontario, Canada
M3J 2P9

45 Brandon Street
Moncton, New Brunswick
E1C 7E7

HOMELITE TEXTRON

Homelite Division of Textron Inc.