

*Echord*

# HOMELITE

## Chain Saw

September 1957

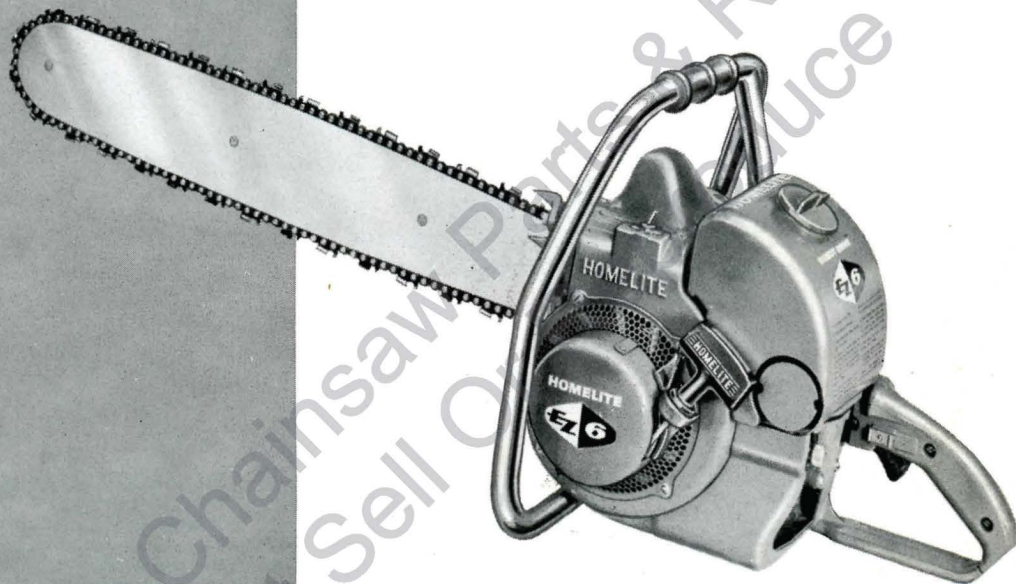

### PARTS LIST



**Model EZ-6**



# HOMELITE CHAIN SAW MODEL EZ-6

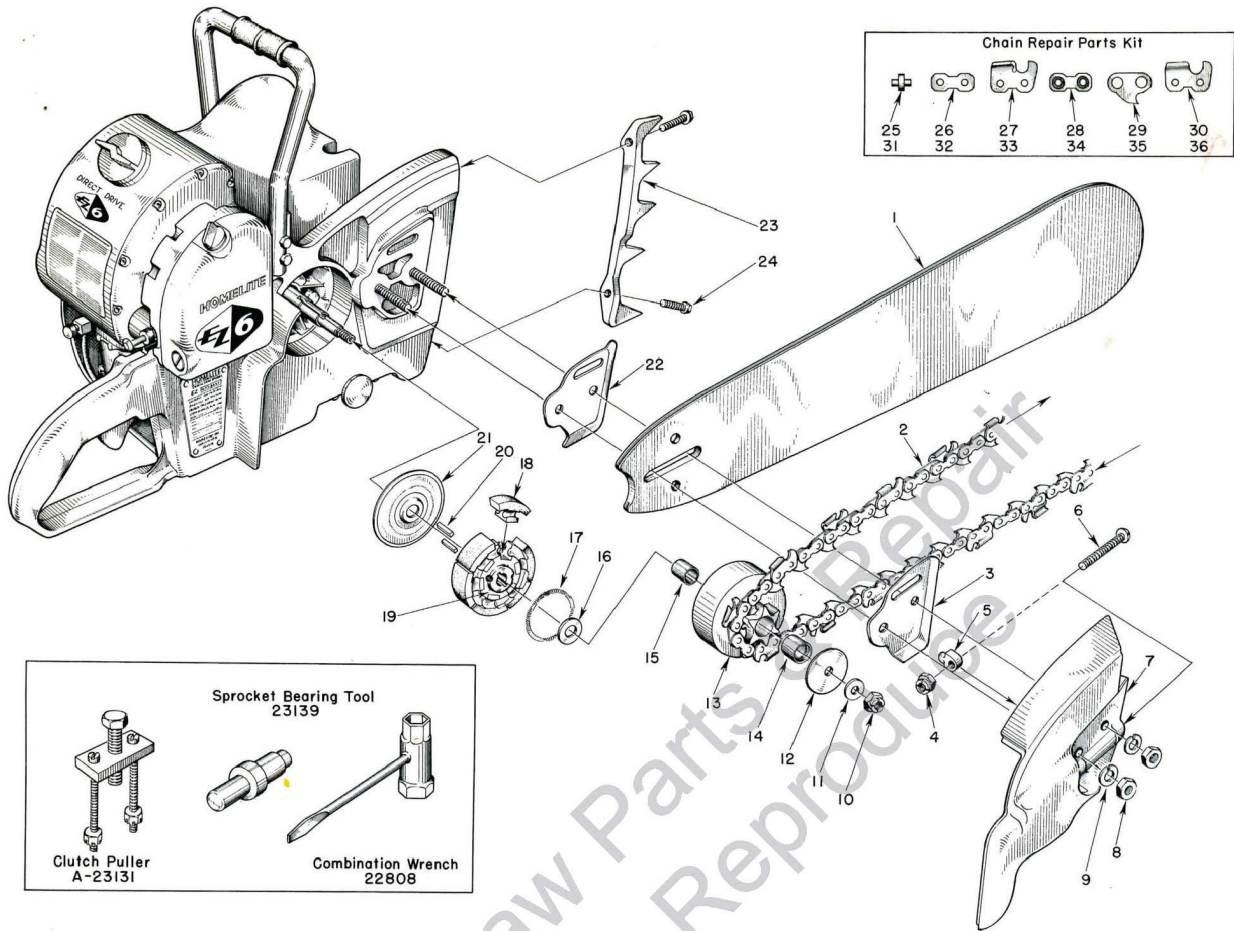

FIGURE 1 — SAW PARTS

SEPTEMBER 1957

Index No.	Part No.	Description	No. Required	Index No.	Part No.	Description	No. Required
1	A-51545	12" BAR — extra hard tip — hard track....	1	13	A-55662	SPROCKET and DRUM (for 7/16 pitch chain)....	1
	A-51517	17" BAR — extra hard tip — hard track....	1	14	55664	BEARING — needle (included in A-55662)	1
	A-51521	21" BAR — extra hard tip — hard track....	1	15	55661	RACE — inner.....	1
	A-51525	25" BAR — extra hard tip — hard track....	1	16	55660	WASHER — thrust.....	1
	A-51539	30" BAR — extra hard tip — hard track....	1		A-56100	CLUTCH .....	1
		OREGON #62C 7/16 PITCH — CHIPPER CHAIN				Includes	
2	A-51542	12" CHAIN — (with kit).....	1	17	55123-A	SPRING — clutch.....	2
	A-51535	17" CHAIN — (with kit).....	1	18	55076-1	SHOE — clutch.....	6
	A-51536	21" CHAIN — (with kit).....	1	19	55075-1	SPIDER — clutch.....	1
	A-51537	25" CHAIN — (with kit).....	1	20	55225	KEY .....	2
	A-51540	30" CHAIN — (with kit).....	1	21	56101	COVER — clutch.....	1
		ATKINS #763C 7/16 PITCH — CHAMFERED CHAIN		22	55666	PLATE — guide bar, inner.....	1
	A-51566	12" CHAIN — (with kit).....	1	23	55632	PLATE — spiked bumper.....	1
	A-51568	17" CHAIN — (with kit).....	1	24	80573	SCREW — 1/4-20 x 1 1/4 hex. hd.....	2
	A-51570	21" CHAIN — (with kit).....	1		A-51529	REPAIR KIT — OREGON #62C chain.....	1
	A-51572	25" CHAIN — (with kit).....	1			Includes	
	A-51574	30" CHAIN — (with kit).....	1	25	51518	RIVET .....	4
3	55667	PLATE — guide bar, outer.....	1	26	A-51528	LINK — connecting (w/rivets).....	2
	A-55668	COVER — drive case.....	1	27	51527	CUTTER — left.....	1
		Includes		28	51519	LINK — connecting (plain).....	2
4	81123	NUT — hex lock.....	1	29	51520	LINK — drive.....	1
5	55613	PIN — guide bar adjusting.....	1	30	51526	CUTTER — right.....	1
6	80617	SCREW — 5/16-18 x 2 rd. hd.....	1		A-51556	REPAIR KIT — ATKINS #763C chain.....	1
7	*	COVER .....	1			Includes	
8	81089	NUT — 3/8-16 hex.....	2	31	51564	RIVET .....	4
9	83018	WASHER — lock.....	2	32	A-51559	LINK — connecting (w/rivets).....	2
10	81116	NUT — 3/8-24 flex-lock.....	1	33	51561	CUTTER — left.....	1
11	84010	WASHER — 3/8 flat.....	1	34	51558	LINK — connecting (plain).....	2
12	55163-1	WASHER — thrust.....	1	35	51557	LINK — drive.....	1
				36	51560	CUTTER — right.....	1

\* Not Sold Separately

# HOMELITE CHAIN SAW MODEL EZ-6

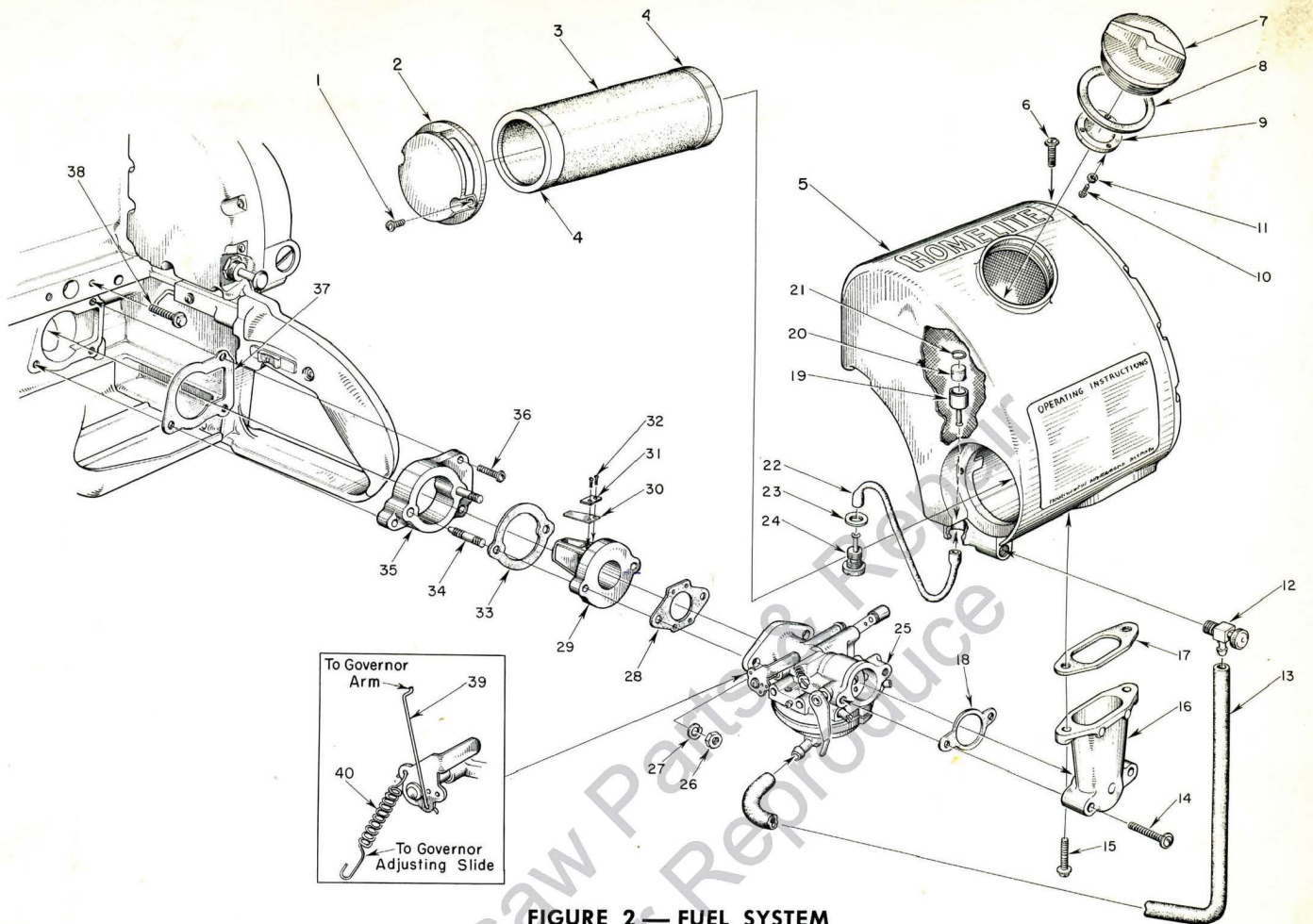

FIGURE 2 — FUEL SYSTEM

SEPTEMBER 1957

Index No.	Part No.	Description	No. Required
1	80571	SCREW — 6-32 x 3/8 pan hd.....	2
2	55494	CAP — air filter.....	1
3	A-55533	AIR FILTER .....	1
		Includes	
4	55532	GASKET (cemented to element).....	2
5	A-55670-1	FUEL TANK .....	1
6	80572	SCREW — 10-32 x 5/8 pan hd. ....	1
7	A-55305	CAP — fuel.....	1
		Includes	
8	72173	GASKET .....	1
9	A-55301-B	VALVE — relief.....	1
10	80592	SCREW — 3-48 x 1/4 rd. hd.....	3
11	83083	WASHER — lock.....	3
12	55677	VALVE — shut-off.....	1
13	55680	FUEL LINE .....	1
14	80624	SCREW — 10-32 x 1 pan hd.....	2
15	80572	SCREW — 10-32 x 5/8 pan hd.....	2
16	55019-3	ADAPTER — air cleaner.....	1
17	55059	GASKET — adapter .....	1
18	72971-1	GASKET — air elbow.....	1
19	A-74375	STRAINER — outlet .....	1

Index No.	Part No.	Description	No. Required
		Includes	
20	74374	FILTER — felt.....	1
21	74380	RING — snap.....	1
22	55805	SLEEVE — flexible .....	1
23	55676	GASKET — outlet fitting.....	1
24	55572	FITTING — outlet.....	1
25	*	CARBURETOR .....	1
26	81013	NUT — 1/4-20 hex.....	2
27	83009	WASHER — lock.....	2
28	55553	GASKET — carburetor.....	1
29	55932	ADAPTER — reed valve.....	1
30	55941	REED .....	4
31	55942	PLATE — reed.....	4
32	80658	SCREW — 4-40 x 3/16 pan hd.....	8
33	55946	GASKET — adapter-spacer .....	1
34	55945	STUD .....	2
35	55934	SPACER — reed adapter.....	1
36	80583	SCREW — 10-32 x 3/4 pan hd.....	3
37	55116	GASKET — reed valve adapter.....	1
38	80581	SCREW — 1/4-20 x 5/8 hex hd.....	2
39	†55642	ROD — governor.....	1
40	‡55529	SPRING .....	1

\* For Brown Carburetor, See Figure 3; For Tillotson Carburetor, See Figure 4.

† Assemble governor rod through bottom rear hole on Model EZ-6

‡ Hook governor spring through forward hole of stop lever.

Always furnish saw model and serial number when ordering parts.



# HOMELITE CHAIN SAW MODEL EZ-6

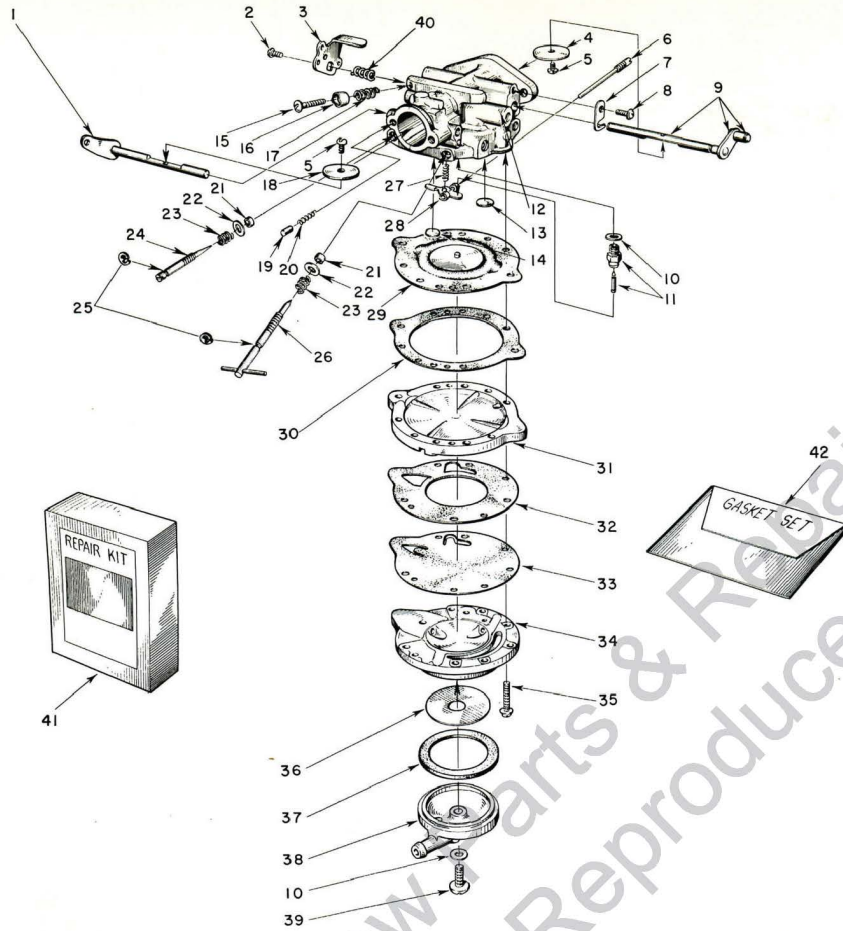

FIGURE 3 — BROWN CARBURETOR PARTS

SEPTEMBER 1957

Index No.	Part No.	Description	No. Required	Index No.	Part No.	Description	No. Required
	A-55928	CARBURETOR—Brown Model 5-CS	1	*20	77017	SPRING—choke friction	1
		Includes		21	†77007	RING—square	2
1	A-77249	SHAFT AND LEVER—choke	1	22	*77006	WASHERS—adjustment packing	2
2	*77042	SCREW—stop lever, 4-40 x 1/4 truss hd.	1	23	*77005	SPRING—adjustment compression	2
3	77247	LEVER—throttle stop	1	24	*A-77251	SCREW—idle adjustment w/77004 clip	1
4	74980	SHUTTER—throttle	1	25	77004	CLIP—spring retaining	2
5	77044	SCREW—shutter, 4-40 x 1/8 rd. hd.	2	26	*A-77001	SCREW—main adjusting w/77004 clip...	1
6	*A-77012	FULCRUM PIN	1	27	*77015	SPRING—tension	1
7	*74981	CLIP—throttle shaft	1	28	*77016	LEVER—diaphragm	1
8	*77041	SCREW—throttle clip, 6-32 x 1/4 pan hd.	1	29	†A-77250	DIAPHRAGM—main	1
9	A-77253	SHAFT—throttle	1	30	†77030	GASKET—main diaphragm	1
†10	77267	GASKET—copper	2	31	77241	COVER—main diaphragm	1
11	*A-74996-A	NEEDLE AND SEAT—inlet w/gasket	1	32	†77025	GASKET—pump body	1
12	A-77248	BODY—service	1	33	†77026	DIAPHRAGM—pump	1
		Includes		34	77027	BODY—fuel pump	1
13	*74977	PLUG—welch 3/8	1	35	77160	SCREW—body 6-32 x 3/4 fl. hd.	6
14	*74978	PLUG—welch 5/16	1	36	*77028	SCREEN—strainer	1
15	77040	SCREW—idle speed, 6-32 x 9/16 rd. hd.	1	37	†77029	GASKET—strainer	1
16	77011	CUP—idle speed screw	1	38	77031	COVER—fuel pump	1
17	77010	SPRING—idle speed screw	1	39	77043	SCREW—turret, 8-32 x 7/16, truss hd.	1
18	74991	SHUTTER—choke	1	40	56175	SPRING	1
19	77018	PLUNGER—choke friction	1	41	77255	REPAIR PARTS KIT (RK-151)	1
				42	*77254	GASKET SET (GS-151)	1

† Included in GS-151 Gasket Set

\* Included in RK-151 Repair Parts Kit

# HOMELITE CHAIN SAW MODEL EZ-6

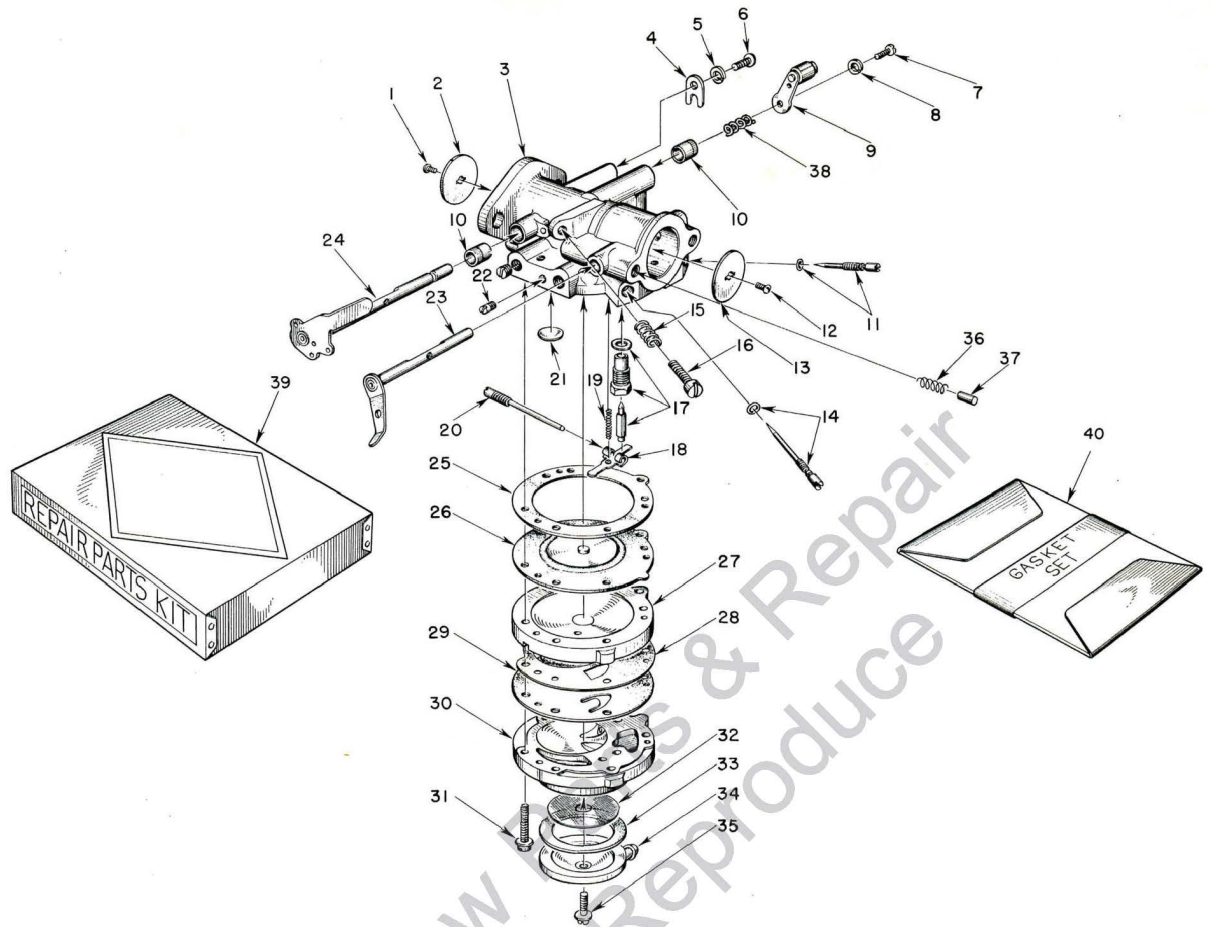

FIGURE 4 — TILLOTSON CARBURETOR PARTS

SEPTEMBER 1957

Index No.	Part No.	Description	No. Required	Index No.	Part No.	Description	No. Required
	A-56066	CARBURETOR—Till. Model HL-27B	1	18	*55747	LEVER—inlet control	1
		Includes		19	*55759	SPRING—control lever	1
1	*80012	SCREW—throttle shutter	1	20	*A-55762	SCREW—pinion	1
2	73272	SHUTTER—throttle	1	21	30818	PLUG	1
3	A-75533	BODY—service	1	22	73067	PLUG—drain	1
4	73086	CLIP—throttle shaft	1		71505	PLUG	2
5	83000	WASHER—lock #8	1	23	A-55766	LEVER—choke	1
6	73088	SCREW—8-32 x 5/16 flat hd.	1	24	A-75624	SHAFT—throttle, w/stop lever	1
7	*71521	SCREW—4-36 x 1/4 rd. hd.	1	25	55754	GASKET—main diaphragm	1
8	*83008	WASHER—lock #4	1	26	*A-55760	DIAPHRAGM—main	1
9	A-75528	LEVER and ROLLER—throttle	1	27	55749	COVER—main diaphragm	1
10	72812	BUSHING—throttle shaft	2	28	55881	GASKET—pump diaphragm	1
11	*A-75527	SCREW—main adjust. (hi speed)	1	29	*55753	DIAPHRAGM—pump	1
		Includes		30	55748	BODY—pump	1
	55764	"O"—ring	1	31	*55316	SCREW and WASHER	6
12	*80012	SCREW—choke shutter (same as No. 1)	1	32	55752	SCREEN—fuel strainer	1
13	73263	SHUTTER—choke	1	33	55751	GASKET—pump cover	1
14	*A-75530	SCREW—idle adjust. (lo speed)	1	34	55750	COVER—pump	1
		Includes		35	55756	SCREW—retaining	1
	55764	"O"—ring	1	36	73264	SPRING—choke friction pin	1
15	*28064	SPRING—idle stop screw	1	37	71494	PIN—choke friction	1
16	*71509	SCREW—idle stop (speed control)	1	38	56175	SPRING	1
17	*A-55761	INLET NEEDLE and SEAT	1	39	75623	REPAIR PARTS KIT (RK-357)	1
		Includes		40	*55836	GASKET SET (GS-122)	1
	55344	GASKET—inlet seat	1				

\* Included in Repair Parts Kit (RK-357)

Always furnish saw model and serial number when ordering parts



# HOMELITE CHAIN SAW MODEL EZ-6

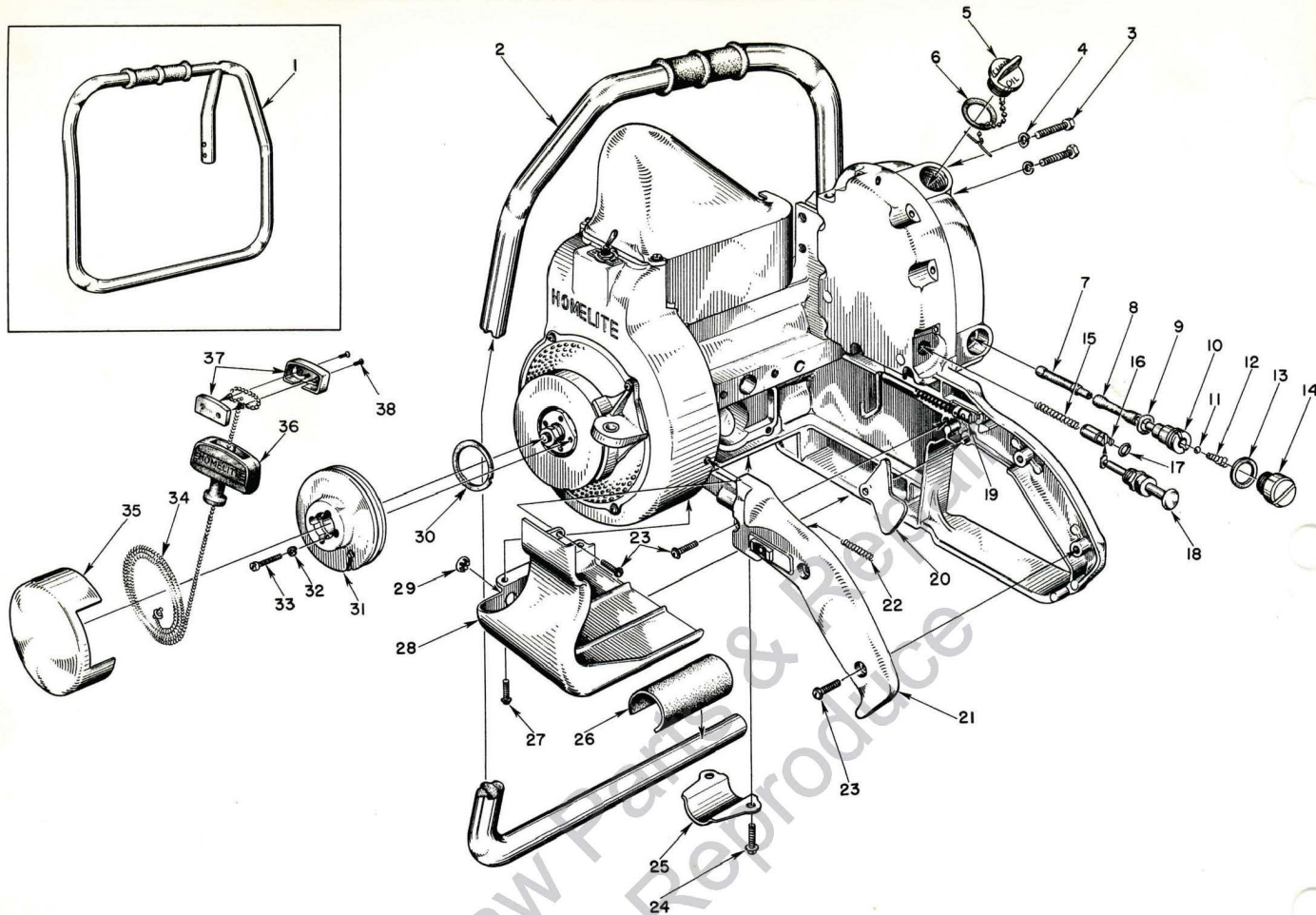

FIGURE 5 — STARTER, HANDLE, GRIP AND LUBRICATOR PARTS

SEPTEMBER 1957

Index No.	Part No.	Description	No. Required	Index No.	Part No.	Description	No. Required	
1	A-56091	HANDLE—wrap-around (EZ-6A) .....	1			Includes		
		Includes		55045-A		SPRING—throttle rod .....	1	
	80308	SCREW—5/16-18 x 1 allen sock't hd. ....	1	20	AA-55207	TRIGGER—throttle .....	1	
2	A-56093	HANDLE—flush-cut (EZ-6) .....	1	21	A-55631	COVER—grip .....	1	
	A-56217	BRACE (for wrap-around handle) .....	1			Includes		
	A-56216	BRACE (for flush-cut handle) .....	1	AA-55282		LOCK—throttle .....	1	
	*80578	SCREW—10-32 x 7/16 pan hd. ....	1			Includes		
	*81109	NUT—10-32 flex lock .....	1	22	72970	SPRING—throttle lock .....	1	
3	80087	SCREW—9/16-18 x 1 1/2 hex hd. ....	2	23	80560	SCREW—8-32 x 1/2 pan hd. ....	4	
4	83003	WASHER—1/16 lock .....	2	24	80581	SCREW—1/4-20 x 5/8 hex hd. ....	2	
5	AA-71655-1	CAP—oil .....	1	25	55614	CLAMP—handle bar .....	1	
		Includes		26	55685	CUSHION—rubber .....	1	
6	72280	GASKET .....	1	27	80625	SCREW—10-32 x 1/2 pan hd. ....	2	
7	AA-55259-A	FINDER—oil .....	1	28	A-55682	SHIELD—carburetor .....	1	
8	55133-A	SLEEVE—flexible oil .....	1			Includes		
9	55110	GASKET .....	1	29	55681	PLUG—button .....	1	
10	55109-A	FITTING—check valve .....	1	30	71588	SHIM—plastic .....	As req'd.	
11	25527	BALL (5/32 dia.) .....	1	31	A-55658	PULLEY (Includes 71577 pin) .....	1	
12	55288-A	SPRING .....	1	32	83004	WASHER—lock #6 .....	4	
13	55107	GASKET .....	1	33	80475	SCREW—6-32 x 3/4 fil. hd. ....	4	
14	A-55628	CAP—supply line .....	1	34	55898	ROPE—starting .....	1	
15	71762	SPRING .....	1	35	AA-73234-4	COVER—starting pulley .....	1	
16	A-74406	TUBE—plunger .....	1			56031	DECAL ("Homelite EZ-6") .....	1
		Includes		36	55937	GRIP—starting .....	1	
17	74388	"O" ring .....	1	37	A-56081	INSERT—grip (w/screws) .....	1	
18	71764	BUTTON—plunger .....	1			Includes		
19	A-55630	ROD—throttle .....	1	38	80619	SCREW .....	2	

\* Supplied with A-56216 or A-56217 brace.

# HOMELITE CHAIN SAW MODEL EZ-6

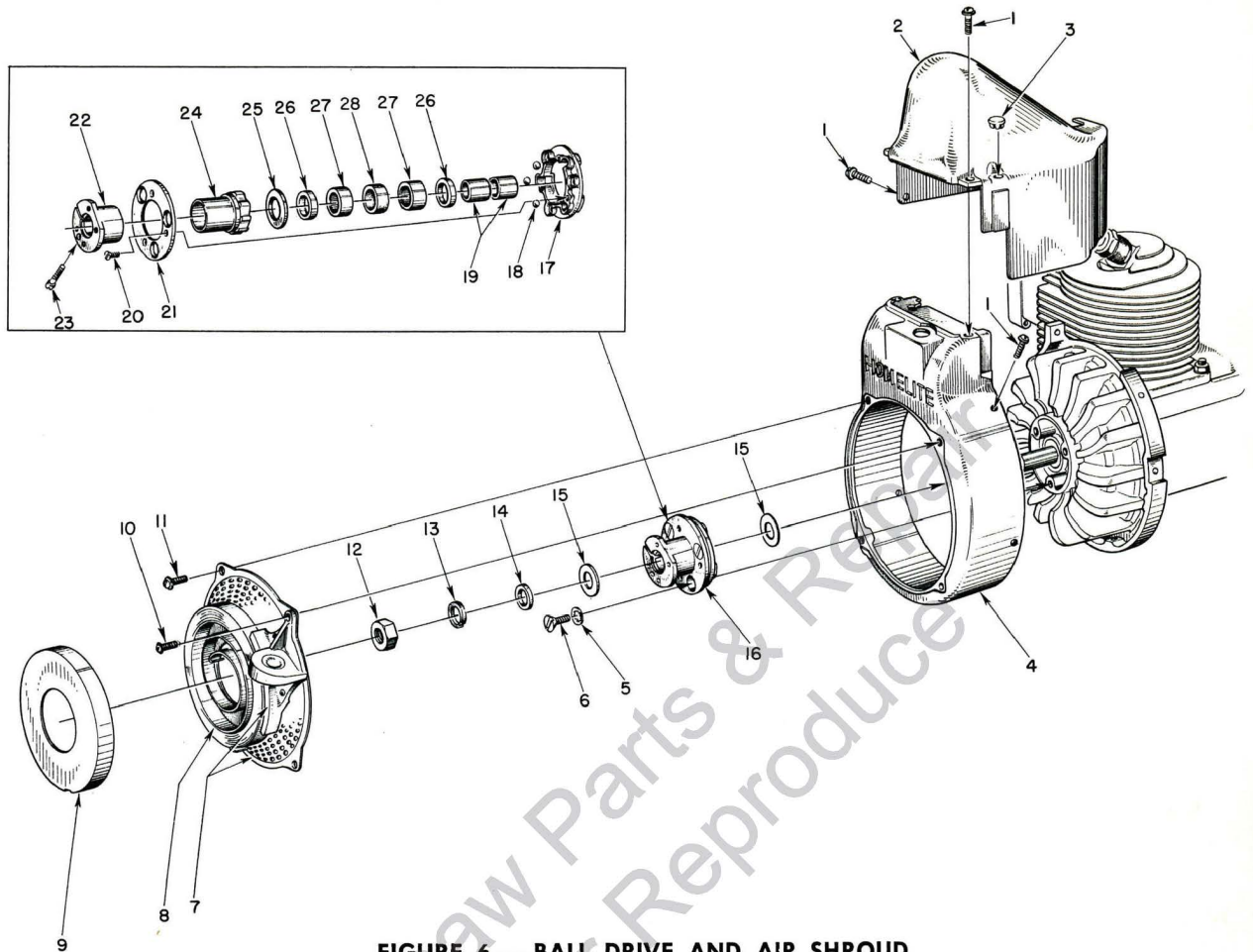

FIGURE 6 — BALL DRIVE AND AIR SHROUD

SEPTEMBER 1957

Index No.	Part No.	Description	No. Required
1	80577	SCREW—8-32 x 3/8 pan hd. ....	7
2	55015-1	SHIELD—cylinder .....	1
3	32814	PLUG—button .....	1
4	A-56063	SHROUD—air .....	1
5	83074	WASHER—lock, countersunk 1/4 .....	3
6	80173	SCREW—1/4-20 x 5/8 flat hd. ....	3
7	A-56088	SCREEN and BRACKET .....	1
		Includes	
	A-56085	BRACKET and BUSHING .....	1
		Includes	
	55363-A	BUSHING .....	1
8	71470-A	SPRING—recoil .....	1
9	71603	COVER—spring housing .....	1
10	80576	SCREW—10-32 x 7/16 (through bracket) .....	1
11	80579	SCREW—10-32 x 3/8 pan hd. ....	3
12	81110	NUT—7/16-20 hex-jam .....	1
13	83019	WASHER—lock, 7/16 .....	1
14	84055	WASHER—flat aluminum, 7/16 .....	1
15	55652	WASHER—thrust .....	2

Index No.	Part No.	Description	No. Required	
16	A-56096	BALL DRIVE .....	1	
		Includes		
17	71563-C	PLATE—ball drive .....	1	
18	30355-1	BALL—steel .....	3	
19	74221	RACE—inner .....	2	
20	80464	SCREW—5-40 x 5/16 flat hd. ....	3	
	A-56095	RATCHET and HUB .....	1	
		Includes		
	21	Retainer—ball .....	1	
	22	A-56181	HUB—ratchet .....	1
		Includes		
	23	SCREW—ratchet hub .....	1	
	AA-72306-1	RATCHET and BEARING .....	1	
		Includes		
	24	AA-73549	RATCHET .....	1
		Includes		
	25	73525	WASHER—formica .....	1
	26	71597	SEAL—garlock .....	2
	27	71596	BEARING—needle .....	2
	28	71595	WICK—felt .....	1

Always furnish saw model and serial number when ordering parts.



# HOMELITE CHAIN SAW MODEL EZ-6

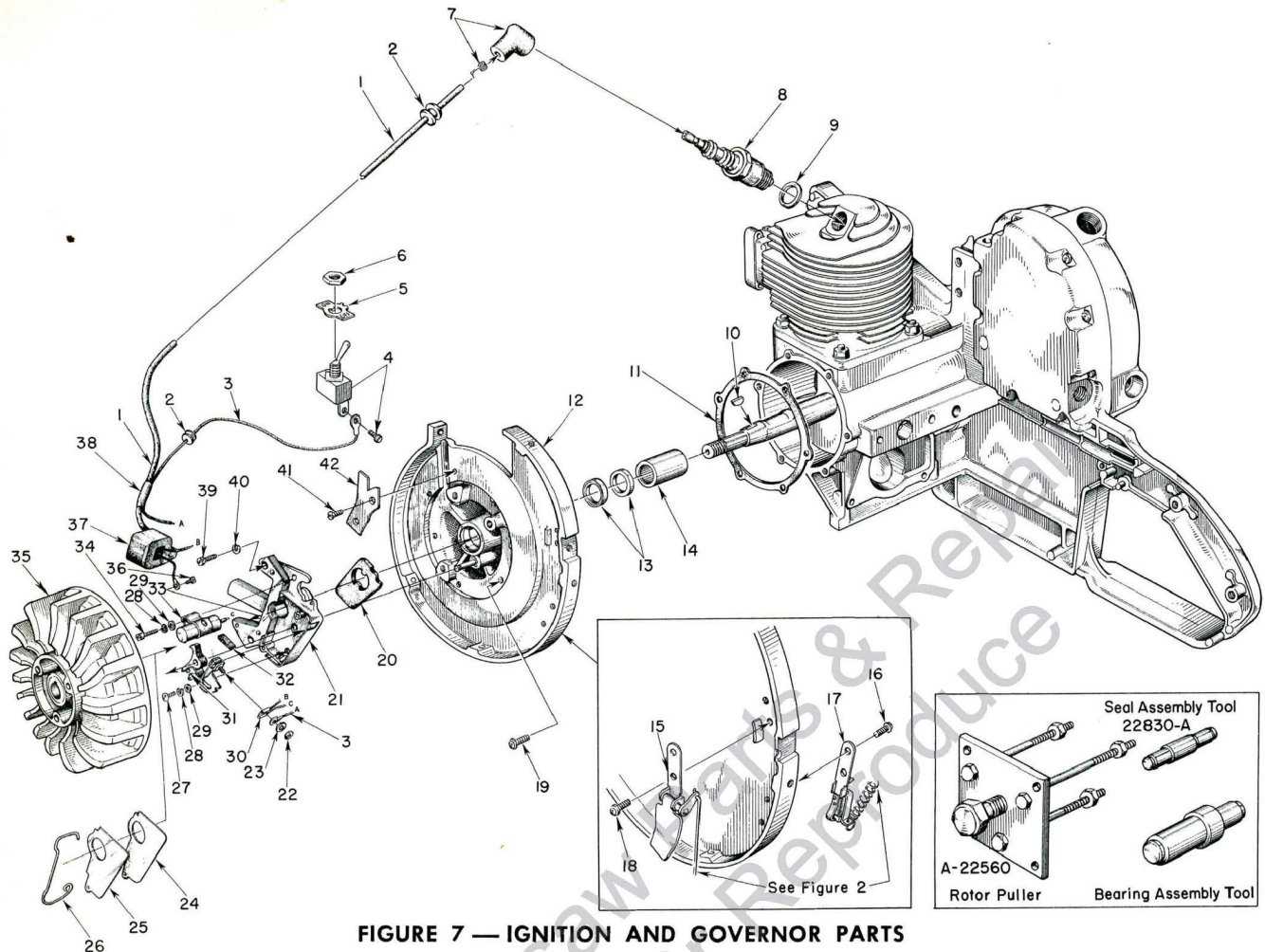

FIGURE 7 — IGNITION AND GOVERNOR PARTS

SEPTEMBER 1957

Index No.	Part No.	Description	No. Required
1	56029	LEAD—high tension .....	1
2	60929	GROMMET .....	2
3	56028	LEAD—ground .....	1
4	AA-72094-A	SWITCH—toggle, w/ screw .....	1
		Includes	
5	55879	PLATE—"on-off" .....	1
6	72084-A1	NUT—hex .....	1
7	A-55373	TERMINAL—"Sparky" (cover & spring) .....	1
8	71530	SPARK PLUG (HO-8A) .....	1
9	25038	GASKET (included with spark plug) .....	1
10	75078	KEY—rotor .....	1
11	55049	GASKET—back plate .....	1
12	A-56180	BACK PLATE (with pivot post) .....	1
		Includes	
13	71597	SEAL—garlock .....	2
14	55204	BEARING—needle .....	1
15	A-56150*	GOVERNOR—vane .....	1
16	80629	SCREW—8-32 x 5/16 pan hd. ....	2
17	A-55645**	PLATE—governor adjusting .....	1
18	80605	SCREW—6-32 x 5/16 pan hd. ....	2
19	80576	SCREW—10-32 x 3/16 pan hd. ....	6
20	55989	WASHER—sealing, felt .....	1

Index No.	Part No.	Description	No. Required
21	55969	BOX—breaker, w/ core .....	1
22	55982	NUT—terminal .....	1
23	55983	WASHER—terminal .....	1
24	55978	GASKET—dust cover .....	1
25	55979	COVER—dust .....	1
26	55980	CLAMP—dust cover .....	1
27	55985	SCREW—8-32 x 3/8 fil. hd. ....	1
28	83060	WASHER—lock .....	2
29	84048	WASHER—flat .....	2
30	55981	TERMINAL (Jam:tite) .....	1
31	A-55971	POINTS (set) .....	1
32	55984	WICK, felt .....	1
33	55987	CONDENSER (w/terminal 55981) .....	1
34	55988	SCREW .....	1
35	56111	ROTOR .....	1
36	55977	SCREW—coil ground .....	1
37	55986	COIL .....	1
38	56027	SLEEVE—insulating .....	1
39	80660	SCREW—10-24 x 7/8 fil. hd. ....	2
40	83046	WASHER—#10 lock .....	2
41	80598	SCREW—6-32 x 5/16 flat hd. ....	2
42	55595-1	CLAMP—lead .....	1
	56206	TAPE—insulation .....	1

\* Does not include governor rod; see Figure 2.

\*\* Does not include tension spring; see Figure 2.



# HOMELITE CHAIN SAW MODEL EZ-6

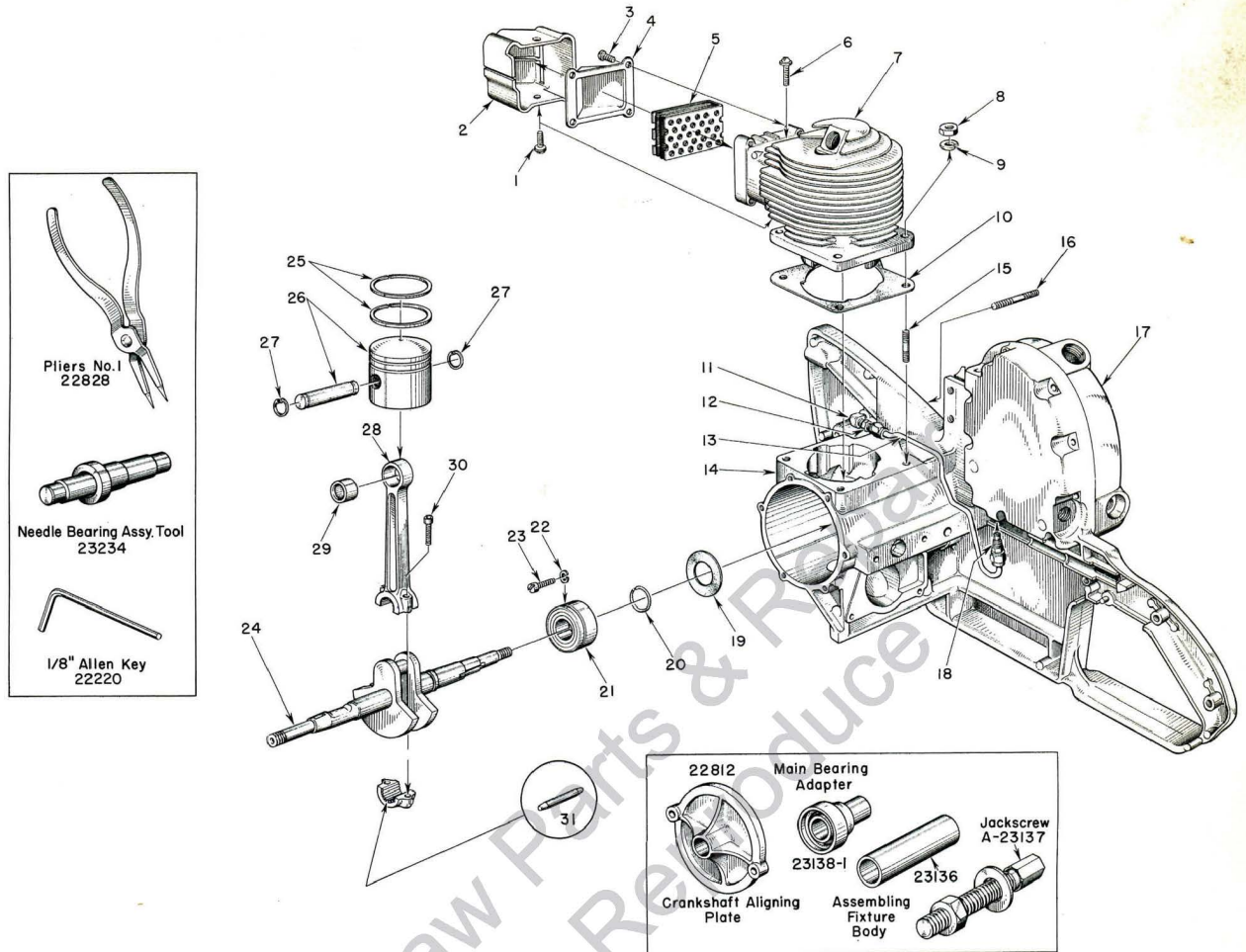

**FIGURE 8 — ENGINE ASSEMBLY**

SEPTEMBER 1957

Index No.	Part No.	Description	No. Required
1	80625	SCREW — 10-32 x 1/2 pan hd.	1
2	55506-1	DAMPER—heat	1
3	80666	SCREW—6-32 x 1/2 fl. hd.	4
	56218	WIRE—.018" dia. x 6"	2
4	55507	CAP—exhaust	1
5	A-56068	ELEMENT—muffler	1
6	80583	SCREW—10-32 x 3/4 pan hd.	1
7	55490	CYLINDER	1
8	81065-2	NUT—hex 1/4-28	4
9	83009	WASHER—lock 1/4	4
10	55050-A	GASKET—cylinder	1
11	31734	ELBOW—connector 90°	1
12	31733-1	ADAPTER—straight	1
13	A-55625	LINE—chain oil	1
14	A-56202	CRANKCASE—w/pivot pin	1
		Includes	
15	55871	STUD—cylinder	4
16	55623	STUD—guide bar	2
17	A-55621	COVER—oil reservoir	1

Index No.	Part No.	Description	No. Required
	55833	GASKET—reservoir cover	1
	80622	SCREW—self-tapping	9
	55372	PAD—felt	1
18	A-55824	VALVE—check	1
19	55048-A	GASKET—crankcase sealing	1
20	56109	RING—snap	1
21	56097	BEARING—main	1
22	83061	WASHER—lock, special thin	2
23	19238-A	SCREW—main bearing retaining	2
24	56098	CRANKSHAFT	1
25	55537	RING—piston	2
26	A-55599	PISTON and PIN	1
		Includes	
27	55095	RING—piston pin retaining	2
28	AA-55195	CONNECTING ROD	1
		Includes	
29	55196	BEARING—piston pin	1
30	80541	SCREW—8-32 x 1/2 allen cap	2
31	AA-55280	ROLLERS (set of 27)	1

# HOMELITE CHAIN SAW MODEL EZ-6

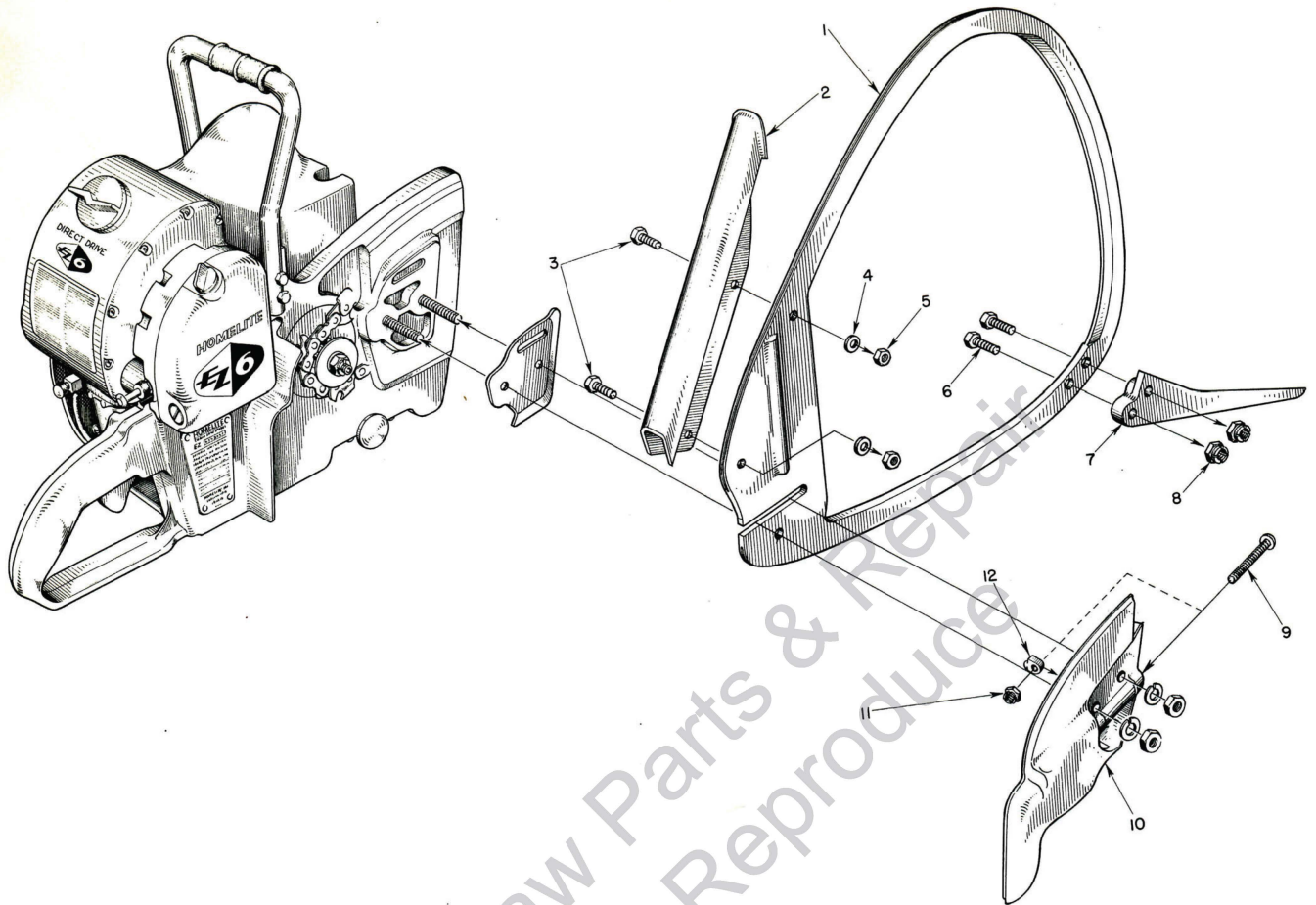

FIGURE 9 — BOW SAW PARTS

SEPTEMBER 1957

Index No.	Part No.	Description	No. Required
1	55953	GUIDE—14" Bow .....	1
	A-56012	KIT—bow mounting .....	1
		Includes	
2	55952	GUARD .....	1
3	80355	SCREW—hex hd. 1/4-20 x 1/2 .....	2
4	83009	WASHER—lock 1/4 .....	2
5	81013	NUT—hex 1/4-20 .....	2
6	80546	SCREW—hex hd. 5/16-24 x 1 1/4 .....	2

Index No.	Part No.	Description	No. Required
7	72784	SPUR .....	1
8	81112	NUT—hex 5/16-24 .....	2
	A-55668-1	COVER—drive case .....	1
		Includes	
9	80617	SCREW—rd. hd. 5/16-18 x 2" .....	1
10	55519-1	COVER .....	1
11	81123	NUT—hex lock 5/16-18 .....	1
12	55613	PIN—adjusting .....	1

Note: Use 21" length, 7/16 pitch chain.



**You'll  
SPEED WORK  
and make  
MORE MONEY  
with...**



**HOMELITE  
SELF-PRIMING PUMPS**

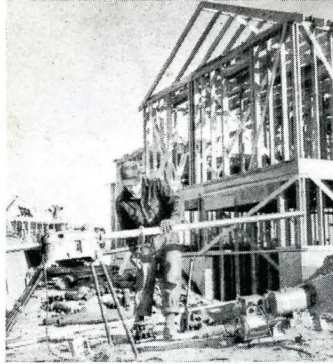

**HOMELITE  
DEPENDABLE GENERATORS**



**HOMELITE  
POWERFUL ONE-MAN CHAIN SAWS**



**HOMELITE  
ONE-MAN CONCRETE VIBRATORS**



**HOMELITE — BOSCH (Germany)  
ELECTRIC BUILDER'S HAMMERS**

**All Powered By Famous HOMELITE Engines**

Homelite's two-cycle gasoline engines are the most efficient and dependable units of their kind ever built. Their two-cycle design, developed to perfection by Homelite engineers over the past 35 years, gives maximum power for the least weight because power is produced at every piston down stroke. As an added advantage, this design requires fewer moving parts which means greater dependability and lower maintenance.

Part No. 23218-2

20M-9-57

**HOMELITE**  
a division of Textron Inc.  
PORT CHESTER, N. Y.

A TRUSPECTIVE Publication by  
The PURNELL COMPANY  
Boston, Mass.