

3rd EDITION

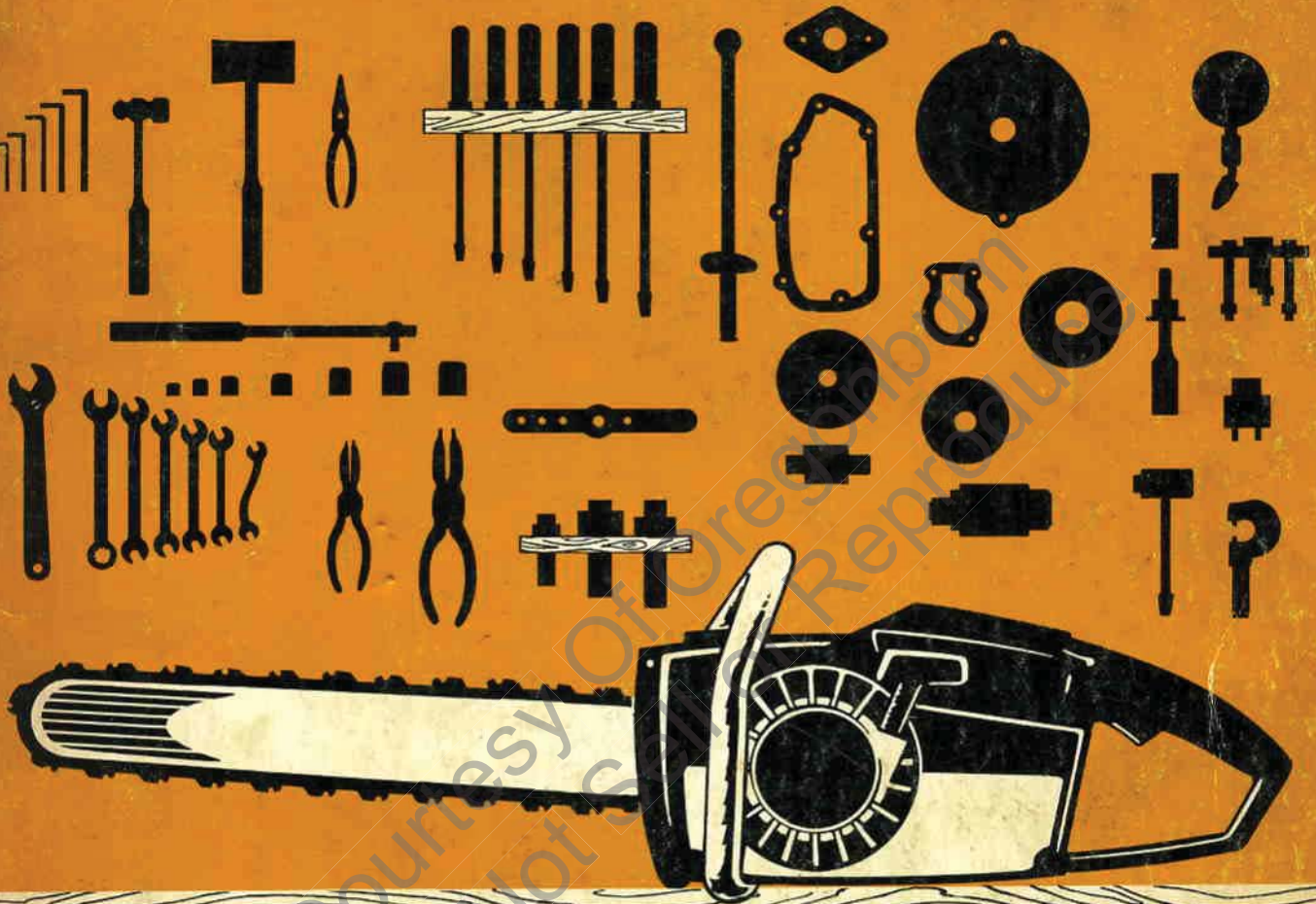

HOMELITE®

**SHOP
SERVICE MANUAL**

HOMELITE® SHOP SERVICE MANUAL

(THIRD EDITION)

CONTENTS

FUNDAMENTALS SECTION

| | | | |
|--|----|--------------------------------------|----|
| 2-Cycle Engine Operating Principles | 3 | Carburetor Servicing | 14 |
| Carburetor Operating Principles | 4 | Disassembly and Assembly | 15 |
| Ignition System Operating Principles | 6 | Repairing Damaged Threads | 15 |
| Ignition System Servicing | 11 | SAW CHAIN MAINTENANCE | 16 |
| Spark Plug Servicing | 13 | IGNITION SYSTEM SPECIFICATIONS | 28 |

CHAIN SAW SERVICE SECTION

| Page No. | Models Covered |
|----------|---|
| 29 | EZ, EZ Automatic, EZ-M, XL-Mini, XL-Mini Automatic |
| 34 | XL-12, XL-15, Super XL-12, Super XL-15, XL-Automatic, XL-Automatic Gear Drive, Super XL, Super XL-Automatic, XL-500 Automatic |
| 43 | C-5, C-51, C-52, C-7, C-71, C-72, C-9, C-91, C-51G, C-71G, C-91G, XP-1000, XP-1020, XP-1020 Automatic, Super XP-1020, Super XP-1020 Automatic, XP-1100, XP-1130, XP-1130A, Super XP-1130A, 2000, 2000E, 2000P, Super 2000 |
| 55 | XL-700, XL-800, XL-800AM, XL-850, XL-870, XL-875, XL-900E, XL-900EAM, XL-901, XL-903, XL-903E, XL-903EAM, XL-904 |
| 64 | XL-101, XL-102, XL-102 Automatic, XL-103, XL-103E, XL-104, XL-104E |
| 73 | ZIP, WIZ, Super WIZ, WIZ55, Super WIZ55, Super WIZ66, Super 77, 775-D, 775-G, 995-D, 995-G. |
| 82 | 5-30N Belt Drive |
| 86 | Servicing the Homelite Capacitor Discharge Ignition System |

CONSTRUCTION EQUIPMENT SERVICE SECTION

| Page No. | Models Covered |
|----------|--|
| 88 | 250 Series Pumps, Generators, Blowers |
| 93 | 251 Series Pumps, Generators |
| 100 | 8, 9, 9-A, 20, 23, 24, 35 & 36 Pumps, Generators |
| 106 | XL Series Brushcutters, Circular Saws, Generators, Pumps |
| 113 | XL-88 Multi-Purpose Saw |

For list of Homelite factory branches, see page 120

FUNDAMENTALS SECTION

ENGINE FUNDAMENTALS

OPERATING PRINCIPLES

The power source for the chain saw does not differ basically from that used to power automobiles, farm or garden tractors, lawn mowers, or many other items of power equipment in use today. All are technically known as "Internal Combustion, Reciprocating Engines."

The source of power is heat formed by the burning of a combustible mixture of petroleum products and air. In a reciprocating engine, this burning takes place in a closed cylinder containing a piston. Expansion resulting from the heat of combustion applies pressure on the piston to turn a shaft by means of a crank and connecting rod.

The fuel mixture may be ignited by means of an electric spark (Otto Cycle Engine) or by the heat of compression (Diesel Cycle). The complete series of events which must take place in order for the engine to run may occur in one revolution of the crankshaft (referred to as Two-Stroke Cycle), or in two revolutions of the crankshaft (Four-Stroke Cycle).

As the two-stroke cycle spark ignition engine is universally used as the power source for chain saws, this will be the only type engine discussed in this section.

OTTO CYCLE. In a spark ignited engine, a series of five events are required in order to provide power. This series of events is called the Cycle (or Work Cycle) and is repeated in each cylinder as long as work is done. The series of events which comprise the work cycle are as follows:

1. The mixture of fuel and air is pushed or drawn into the cylinder, by reducing cylinder pressure to less than the outside pressure, or by applying an initial, higher pressure to the fuel charge.
2. The mixture is compressed, or reduced in volume.
3. The mixture is ignited by a timed electric spark.
4. The burning fuel-air mixture expands, forcing the piston down, thus converting the generated chemical energy into mechanical power.
5. The burned gases are exhausted from the cylinder so that a new cycle can begin.

The series of events comprising the work cycle are commonly referred to as **INTAKE, COMPRESSION, IGNITION, EXPANSION (POWER), and EXHAUST.**

TWO-STROKE CYCLE. In a two-stroke cycle engine, the five events of intake, compression, ignition, power and exhaust must take place in two strokes of the piston; or one revolution of the crankshaft. Thus, a compressed fuel charge is fired each time the piston reaches the top of the cylinder, and each downward stroke is a power stroke. In order to accomplish this, the initial pressure of the incoming fuel-air mix-

ture must be raised to a point somewhat higher than the lowest pressure existing in the cylinder, or a fresh charge of fuel could not be admitted and the engine would not run. This elevation of pressure requires the use of an air pump, or compressor, of approximately the same volume as the cylinder itself. Coincidentally, such an air pump is available with a minimum of additional parts, cost, or friction losses by utilizing the opposite side of the piston and cylinder as the pump. Such engines are called "Crankcase Scavenged," and are universally used in the chain saw industry.

Fig. CS1 shows a schematic view of the crankcase scavenged, reed valve type, two-stroke cycle engine commonly used. The general sequence of events required for operation is as follows: As the piston moves outward from the crankshaft as shown in view "B", the volume of the closed crankcase is enlarged and the pressure lowered, causing air to be drawn through the carburetor (C), where it is mixed with fuel. This mixture is then drawn through the reed valve (R) and into the crankcase. At the same time, a previous charge of fuel is being compressed between head of piston and closed end of cylinder as shown by the darkened area. As the piston approaches top center, a timed spark ignites the compressed fuel charge and the resultant expansion moves the piston downward on the power stroke. The reed valve (R) closes, and downward movement of piston compresses the next fuel charge in the crankcase as shown in view "A". When the piston nears the bottom of its stroke,

the crown of piston uncovers the exhaust port (EX) in cylinder wall, allowing the combustion products and remaining pressure to escape as shown by the wavy arrow. Further downward movement of piston opens the transfer port (TP) leading from the crankcase to cylinder; and the then higher crankcase pressure forces the compressed fuel-air mixture through transfer port into the cylinder. The baffle which is built into crown of piston deflects the incoming charge upward, and most of the remaining exhaust gases are driven from the combustion chamber by this fresh charge. Two-stroke cycle, crankcase scavenged engines are sometimes produced with a fuel induction system other than the inlet reed valve. The two induction systems used in chain saw engines in addition to the reed valve are the three-port system illustrated in Fig. CS2 and the rotary valve system illustrated in Fig. CS3.

In the crankcase scavenged engine, most of the friction parts requiring lubrication are located in the fuel intake system. Lubrication is accomplished by mixing the required amount of oil with the fuel, so that a small amount of oil in the form of a fine mist is drawn into the crankcase with each fuel charge. It should be pointed out that the new oil brought into the crankcase can do little more than supplement the losses, therefore it is necessary that the friction parts be well lubricated at the time the engine is started. The use of too much oil in the fuel mixture results in plug fouling, excessive carbon, and poor performance, as well as being wasteful.

Fig. CS1 — Schematic view of two-stroke cycle, crankcase scavenged engine used in most chain saws. The series of events comprising the Otto cycle takes place in one revolution of the crankshaft by using the crankcase as a scavenging pump.

C. Carburetor
R. Reed valve
TP. Transfer port
EX. Exhaust port

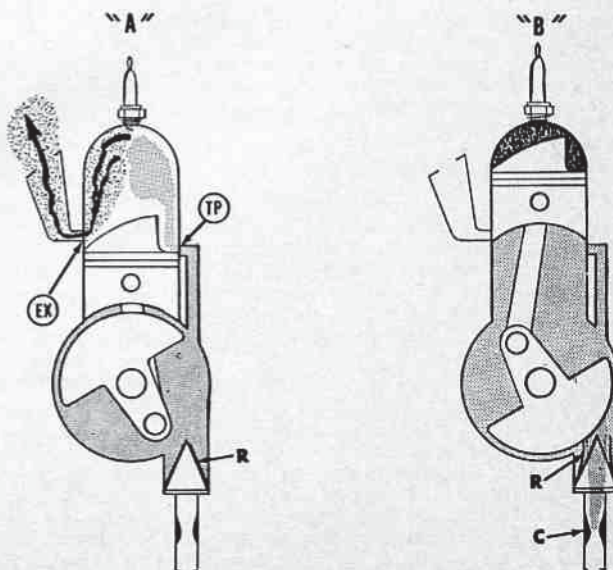

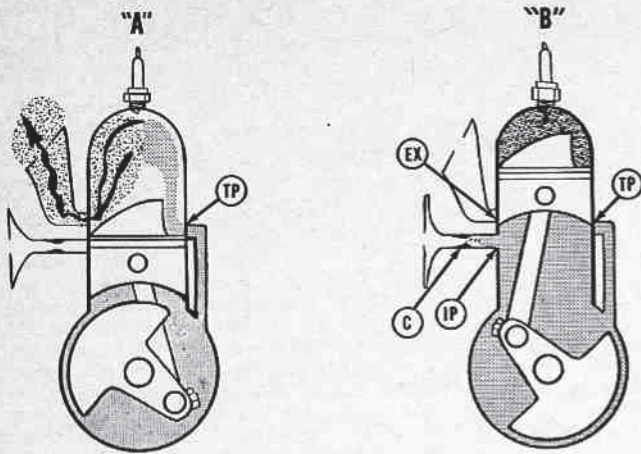

Fig. CS2 — Two cycle, three port engine. Principles are similar to reed valve or rotary valve types except that a third, intake port is located in cylinder wall and opened and closed by the piston skirt.

- C. Carburetor
- EX. Exhaust port
- IP. Intake port
- TP. Transfer port

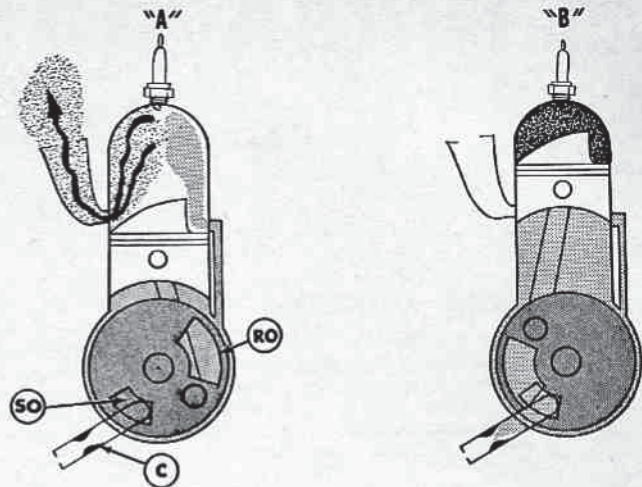

Fig. CS3 — Two cycle, rotary valve engine. The incoming fuel charge is controlled by a rotary valve attached to the crankshaft. The opening in valve (RO) and crankcase (SO) align at the proper time to admit a fresh charge, then close to allow initial crankcase compression.

- C. Carburetor
- RO. Opening in rotating member
- SO. Opening in crankcase wall

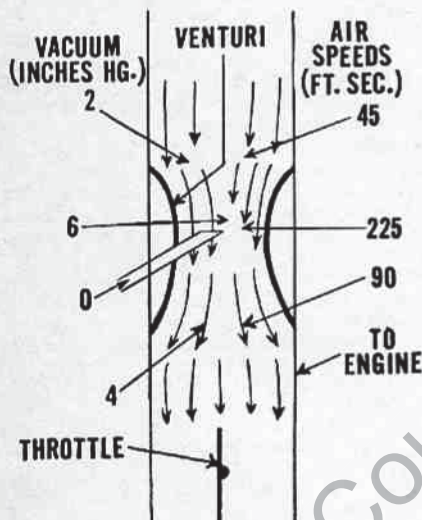

Fig. CS5 — Schematic view of venturi principle. Right hand figures show how air speed is increased by the restriction (venturi) while left hand figures show the accompanying drop in air pressure.

CARBURETION

The function of the carburetor is to atomize the fuel and mix it with the air flowing through the carburetor and into the engine. The carburetor must also meter the fuel so that the proper fuel-air ratio for different engine operating conditions is provided. Normal fuel-air ratios are approximately as follows:

| | Fuel | Air |
|---------------------------------|-------|---------|
| For starting in cold weather.. | 1 lb. | 7 lbs. |
| For idling | 1 lb. | 11 lbs. |
| For full load at open throttle. | 1 lb. | 13 lbs. |

Carburetor design is based on the venturi principle which is that a gas or liquid flowing through a necked-down section (venturi) in a passage undergoes an increase in speed and a decrease in pressure as compared to its speed and pressure

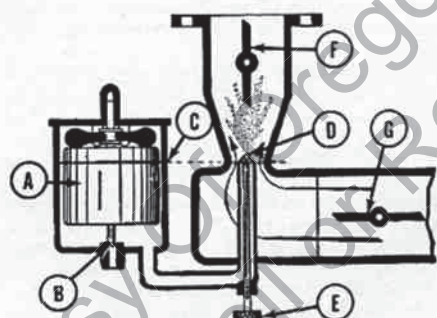

Fig. CS6—Schematic view of simple float-type carburetor. Buoyancy of float (A) closes the fuel inlet valve (B) to maintain fuel level at (C). Pressure drop in the venturi causes fuel to flow out nozzle (D) which is just above fuel level. Fuel flow is controlled by mixture valve (E). Throttle valve is at (F) and choke valve at (G)

in the full sized sections of the passage. This principle is illustrated in Fig. CS5. Due to the low pressure at the venturi, fuel is drawn out through the fuel jet and is atomized by the stream of air flowing through the venturi.

A simple carburetor design is illustrated in Fig. CS6 where flow of fuel into the carburetor is controlled by a float valve. With the float type carburetor, the carburetor must be kept in a nearly upright position for the float valve to function. Early chain saws using this type of carburetor had a provision for tilting the bar and chain independently of the engine.

Later development of a floatless carburetor that would function in any position allowed a more simple and lighter design of chain saws. In this carburetor, the flow of fuel into the carburetor is controlled by linking the inlet valve to a spring-loaded diaphragm. The spring pressure is counteracted by suction through the fuel jets at the venturi of the carburetor.

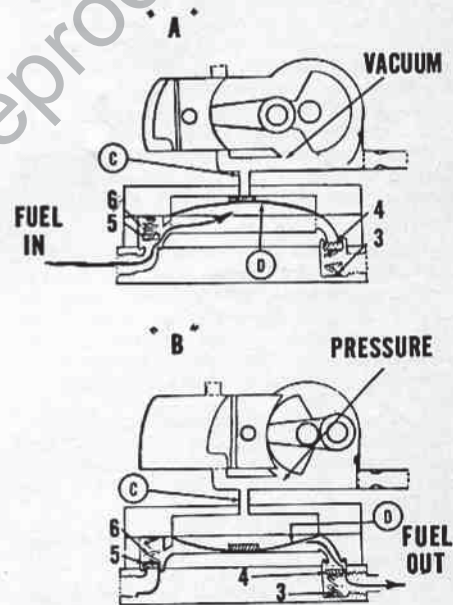

Fig. CS7 — Schematic view of a typical, crankcase operated, diaphragm type fuel pump. Pressure and vacuum pulsations from crankcase pass through connection (C) to rear of diaphragm (D) which induces a pumping action on fuel line as shown.

- 3. Valve spring
- 4. Outlet check valve
- 5. Inlet check valve
- 6. Valve spring

To provide fuel at the carburetor with the engine in an inverted position, a fuel pump is usually incorporated within the diaphragm type carburetor. As the crankcase of 2-cycle engines is subjected to alternate surges of pressure and vacuum at each stroke of the piston, a diaphragm vented to the crankcase will pulsate at each turn of the engine crankshaft. Thus, the pulsating diaphragm can be used as a fuel pump. See Fig. CS7.

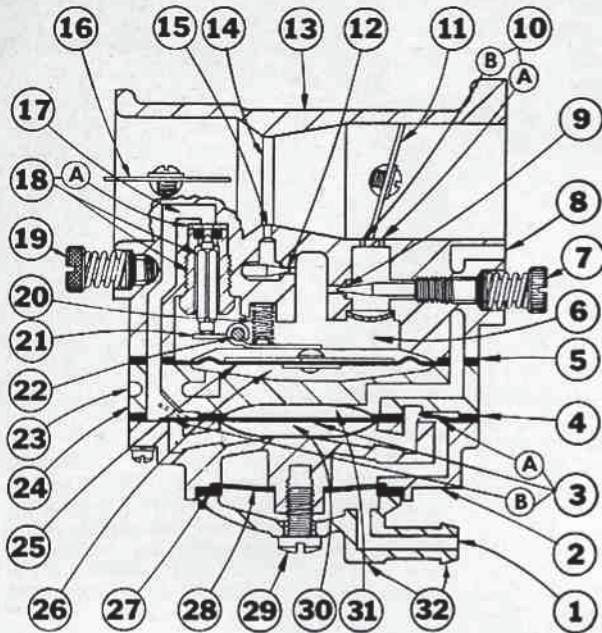

Fig CS8 — Cross-sectional schematic view of Tillotson series HL diaphragm carburetor. Some models of this type carburetor are equipped with an accelerator pump

- | | |
|-----------------------|-------------------------|
| 1. Fuel inlet | 16. Choke shutter |
| 2. Pump body | 17. Inlet channel |
| 3. Pump diaphragm | 18. Inlet valve |
| 3 A&B. Pump valves | 19. Main needle |
| 4. Gasket | 20. Spring |
| 5. Gasket | 21. Diaphragm lever |
| 6. Metering chamber | 22. Fulcrum pin |
| 7. Idle needle | 23. Vent hole |
| 8. Impulse channel | 24. Cover |
| 9. Idle fuel orifice | 25. Diaphragm |
| 10. Idle ports | 26. Atmospheric chamber |
| 11. Throttle shutter | 27. Gasket |
| 12. Main fuel orifice | 28. Screen |
| 13. Body | 29. Screw |
| 14. Venturi | 30. Fuel chamber |
| 15. Main fuel port | 31. Pulse chamber |
| | 32. Strainer cover |

A cross-sectional schematic view of a typical Tillotson series HL diaphragm type carburetor with integral fuel pump is shown in Fig. CS8. The top of the pump diaphragm is vented to the engine crankcase through the channel (8). As the diaphragm pulsates, fuel is drawn into the carburetor through the inlet (1), screen (28) and pump inlet valve (3A). The fuel is then pumped through the outlet valve (3B) into the supply channel (17). Engine suction through the main jet (15) and idle jets (10) is transmitted to the top of the carburetor diaphragm (25) and atmospheric pressure through the vent (23) pushes upward on the diaphragm (25) overcoming spring (20) pressure and unseating the inlet needle (18) allowing fuel to flow into the diaphragm chamber (6).

When starting an engine, closing the choke disc (16) increases the vacuum in the carburetor throat so that the carburetor will function at the low cranking RPM.

When the engine is idling, the throttle disc is almost completely closed and there is not enough air passing through the venturi (14) to create any vacuum on the main jet (15). A vacuum is created at the primary idle jet (10A), however, and the fuel necessary for running the engine is drawn through that jet.

As the throttle disc is opened, enough vacuum is created on the secondary idle jet port (10B) so that fuel is drawn through that port also. At a certain point, the throttle disc is open far enough so that the velocity of air passing through the venturi

is sufficient to lower the pressure at the main fuel discharge port (15) so that fuel will flow through this port also. Opening the throttle disc farther results in higher air velocities and lower venturi pressures that increase the flow of fuel out of the discharge ports.

Fig CS9—Cross-sectional schematic view of Walbro series SDC carburetor with accelerator pump. Some models are not equipped with accelerator pump and passages (8 & 11) are plugged. Fuel cavity above metering diaphragm extends to cavity shown at tip of main fuel needle (14).

- | | |
|-------------------------------|-----------------------------------|
| 1. Fuel inlet | 10. Accelerator spring |
| 2. Surge chamber | 11. Accelerator fuel channel |
| 3. Inlet check valve | 12. Choke disc |
| 4. Crankcase pulse channel | 13. Idle air bleed channel |
| 5. Fuel pump diaphragm | 14. Main (high speed) fuel needle |
| 6. Outlet check valve | 15. Main orifice check valve |
| 7. Fuel filter | 16. Inlet needle |
| 8. Accelerator pulse channel | 17. Metering lever |
| 9. Accelerator diaphragm | 18. Metering diaphragm |
| 20. Metering diaphragm spring | 19. Atmospheric vent |
| 21. Idle fuel channel | |

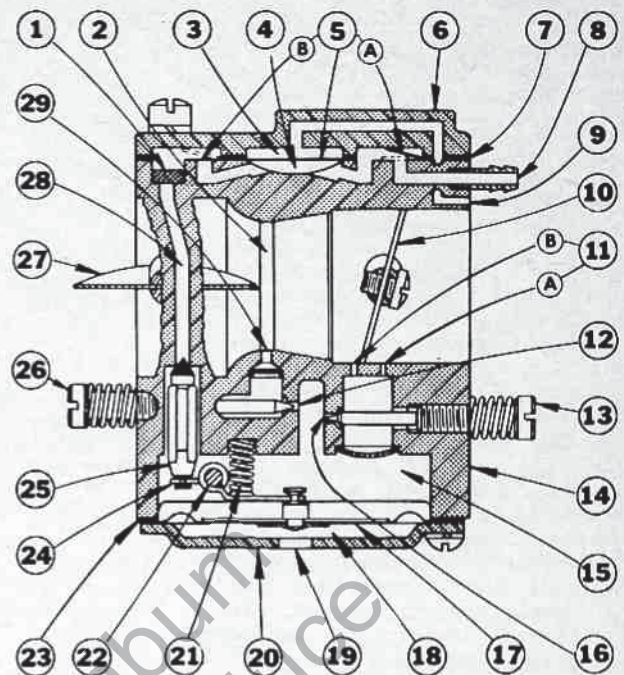
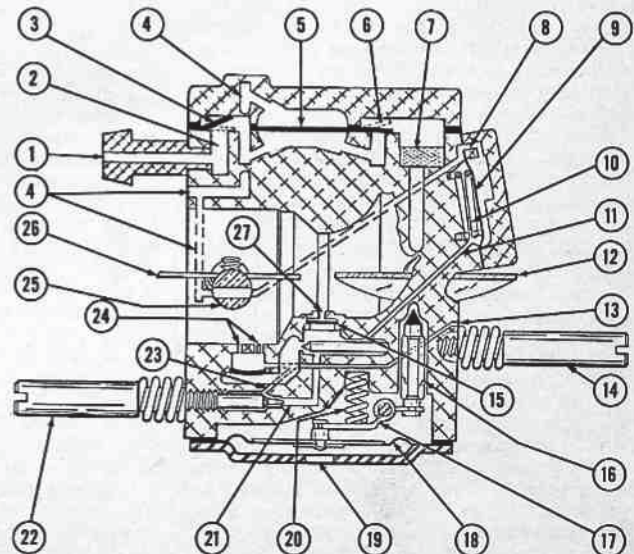

Fig. CS8A — Cross-sectional view of typical Series HS Tillotson diaphragm type carburetor

- | | |
|--|-------------------------|
| 1. Filter screen | 14. Carburetor body |
| 2. Venturi | 15. Metering chamber |
| 3. Pulse chamber | 16. Idle fuel orifice |
| 4. Fuel chamber | 17. Metering diaphragm |
| 5. Pump diaphragm | 18. Atmospheric chamber |
| 5A. Inlet valve | 19. Vent hole |
| 5B. Outlet valve | 20. Diaphragm cover |
| 6. Pump body | 21. Spring |
| 7. Gasket | 22. Fulcrum pin |
| 8. Inlet fitting | 23. Gasket |
| 9. Impulse channel | 24. Diaphragm lever |
| 10. Throttle plate | 25. Inlet valve |
| 11. Primary (A) and secondary (B) idle ports | 26. Main fuel needle |
| 12. Main fuel orifice | 27. Choke disc |
| 13. Idle fuel needle | 28. Inlet channel |
| | 29. Main fuel port |

Any vacuum created at the idle discharge ports (10) or the main fuel discharge port (15) is transferred through the metering chamber (6) to the diaphragm (25). Air pressure entering through the atmospheric vent hole (23) pushes against the diaphragm because of the vacuum and overcomes pres-



- | | | |
|-------------------------------|-----------------------------|-----------------------|
| 20. Metering diaphragm spring | 22. Idle fuel needle | 25. Throttle shaft |
| 21. Idle fuel channel | 23. Idle fuel passage | 26. Throttle disc |
| | 24. Idle air and fuel holes | 27. Main fuel orifice |

sure applied by the spring (20) through the control lever (21). This releases the inlet needle valve (18) and allows fuel to enter the metering chamber in a direct relationship to the vacuum created at the fuel discharge ports. The higher the vacuum, the greater the movement of the diaphragm and the larger the opening of the needle valve. Thus, fuel is metered into the carburetor to meet the needs of the engine.

In Fig. CS8A, a cross-sectional schematic view of a Tillotson series HS carburetor is shown. Operation is basically similar to that described for the Tillotson HL carburetor in preceding paragraphs, the main difference being that the series HS carburetor is a compactly designed unit usually used on lightweight, small displacement engines.

Another compact diaphragm carburetor, the Walbro series SDC, is shown in cross-sectional schematic view in Fig. CS9. Except for some models, the Walbro SDC carburetor is equipped with an accelerator pump. When throttle is open, indexing hole in throttle shaft (25) opens pulse passage (4) to accelerator pump passage (8). Pressure against pump diaphragm (9) compresses spring (10) and pressurizes fuel passage (11), ejecting excess fuel from main nozzle (27). When throttle is closed, or partially closed, indexing hole closes pulse passage and accelerator pump spring returns diaphragm to original position, drawing fuel back up passage (11) to recharge accelerator pump.

At idle speed, air is drawn into carburetor through air bleed hole (13) and mixed with fuel from idle fuel passage in what is called the "emulsion channel". More air enters idle fuel cavity through the two idle holes (24) nearest venturi and the fuel-air mixture is ejected from the third idle hole. Air cannot enter the main fuel nozzle (27) as the check valve (15) closes against its seat when engine is idling. Note that idle fuel supply must first pass main (high speed) metering needle (14) before it reaches idle fuel needle (22).

CONVENTIONAL FLYWHEEL MAGNETO IGNITION SYSTEM

The fundamental principles of the flywheel magneto ignition system in general use on chain saw engines are presented in this section. As the study of magnetism and electricity is an entire scientific field, it is beyond the scope of this manual to fully explore these subjects. However, the information contained in this section should impart a working knowledge of the flywheel type magneto which will be useful when servicing chain saw ignition systems.

BASIC PRINCIPLES. Although the design of different flywheel magnetos varies, all flywheel magnetos operate on the same basic principles of electro-magnetic induction of electricity and formation of magnetic fields by electrical current.

The principle of electro-magnetic induction of electricity is as follows: When a wire (conductor) is moved through a magnetic field so as to cut across lines of magnetic force (flux), a potential voltage (electro-motive force or emf) is induced in the wire. If the wire is a part of a completed electrical circuit, current will flow through the circuit as illustrated in Fig. CS10. It should be noted that the movement is relative; that is, if the lines of force of a moving magnetic field cut across a wire,

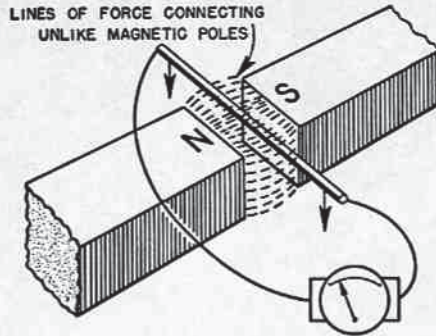

Fig. CS10 — When a wire (conductor) is moved through a magnetic field across lines of magnetic force, an electro-motive force is induced into the wire. If the wire is a part of an electrical circuit, current will flow in the circuit as shown.

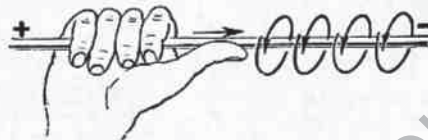

Fig. CS11 — A field of magnetic force is always present around a wire through which current is flowing. The direction of magnetic force is related to the direction of electrical current as shown.

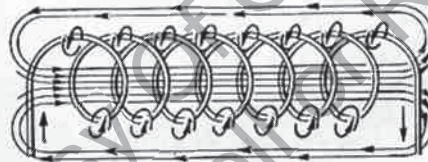

Fig. CS12 — When a wire carrying an electrical current is wound in the shape of a coil or helix, the magnetic field surrounding loops of the wire tend to converge into a single electro-magnetic field as shown. If the loops of the coil are wound closely together, there is very little tendency for the electro-magnetic field to surround individual loops of the coil.

this will also induce an emf in the wire. The direction of the induced current when the wire is a part of a circuit is related to both the direction of magnetic force and the direction of movement of the wire through the magnetic field. The voltage of the induced current is related to the strength of the magnetic field and to the speed at which the wire moves through the lines of magnetic force. Also, if a length of wire is wound into a coil and a section of the coil is moved through a magnetic field so that it cuts across lines of magnetic force, the voltage of the induced current is multiplied by the number of turns of wire in the coil.

The second basic principle involved is that when an electrical current is flowing in a wire, a magnetic field is present around the wire as illustrated in Fig. CS11. The direction of force of the magnetic field is related to the direction of current in the wire and the strength of the magnetic field is related to the rate of flow of the electrical current. If the wire is wound in a coil, the magnetic forces around the wire

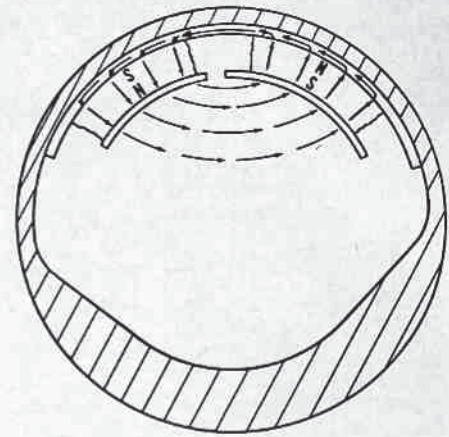

Fig. CS13 — Cut-away of typical flywheel used for magneto rotor. The permanent magnets are usually cast into the flywheel. For flywheel magnetos having the ignition coil and core mounted to outside of flywheel, magnets would be flush with outer diameter of flywheel.

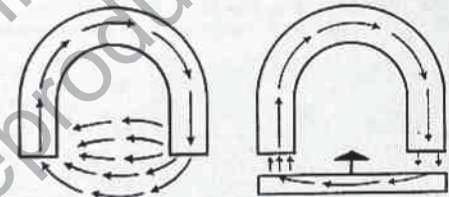

Fig. CS14 — Drawing showing function of magneto armature core. At left, lines of force of permanent magnet are dispersed in the air. When a soft iron bar, which is an excellent conductor of magnetism, is moved close to the magnetic poles, the magnetic field becomes concentrated in the bar.

converge to form a stronger single magnetic field as shown in Fig. CS12. If the wire is coiled closely, there is little tendency for the magnetic forces to surround individual loops of the coil.

When there is a change in the current flowing in a wire, there is a corresponding change in the magnetic field surrounding the wire. If the current ceases to flow, the magnetic field will "collapse." Thus, it can be seen from the illustration in Fig. CS12 that if current in the coiled wire would cease, the collapsing magnetic field would cut across adjacent loops of the coil and the resulting induced current would counteract any change in flow of current through the coil.

CONVENTIONAL FLYWHEEL MAGNETO PARTS. To understand how the flywheel type magneto produces the ignition spark, it is necessary to identify each part of the magneto. The various component parts of the conventional type flywheel magneto are discussed in the following paragraphs.

FLYWHEEL MAGNETS. Permanent magnets are either attached to the flywheel as shown in Fig. CS13 or imbedded into the flywheel casting. Some magnetos use a single ring shaped flywheel magnet; others use two separate magnets as shown in Fig. CS13.

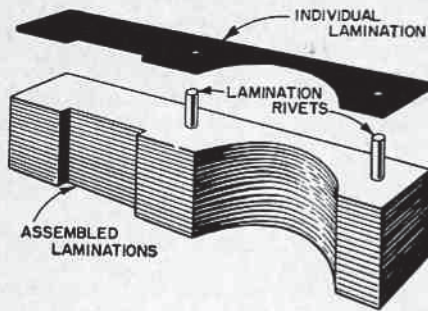

Fig. CS15—To prevent stray electrical currents (eddy currents) from building up within armature core and creating opposing magnetic fields that would decrease efficiency of magneto, armature core is constructed of thin plates (laminations) that are insulated from each other. (Oxide on surfaces of laminations usually provides sufficient insulation, although laminations in some magnetos are painted or varnished.)

Alnico, a steel alloy containing aluminum, nickel and cobalt, is used for the flywheel magnet or magnets as Alnico retains strong magnetic properties for very long periods of time.

ARMATURE CORE (LAMINATIONS). As shown in Fig. CS14, a field of magnetic force surrounds the poles of a permanent magnet at all times. If a soft iron bar is moved close to the magnet, the magnetic field will become concentrated in the bar because soft iron is a very good conductor of magnetic flux. Thus, the armature core is used in the flywheel type magneto to concentrate the field strength of the flywheel magnets.

In the operation of the magneto, electrical currents can be induced into the armature core. To prevent these stray currents (eddy currents) from building up in the armature core and creating magnetic forces which would decrease the efficiency of the magneto, the armature core is built up of thin plates (laminations) as shown in Fig. CS15. Thus, the armature core is sometimes called laminations.

HIGH TENSION COIL. Refer to Fig. CS16 for construction of typical high tension coil. The coil assembly consists of a primary coil (A) of about 100-200 turns of wire and a secondary coil (B) of about 10,000 turns of very fine wire. The wire is insulated, usually with a fine coating of enamel, and a paper insulating strip is placed between each layer of wire. The entire coil assembly is then impregnated with an insulating compound and covered with varnished cloth tape or plastic. Refer to wiring diagram in Fig. CS19 for hook-up of coil leads.

BREAKER (CONTACT) POINTS. Refer to the magneto wiring diagram in Fig. CS19. The breaker points are installed between the lead from the primary coil windings and the magneto ground. The breaker points are opened and closed by a cam which is usually located on the engine crankshaft as shown in Fig. CS17.

CONDENSOR. Refer to Fig. CS18 for construction of a typical condenser. Usually, the lead from one end of the condenser is connected to the metal covering and is thereby grounded through mounting the condenser. The condenser is connected in

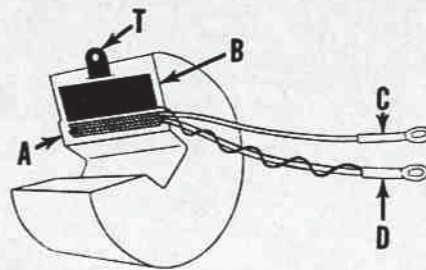

Fig. CS16—Cross-sectional view of a typical high tension coil. Primary windings (A) consist of 100-200 turns of copper wire. Secondary windings consist of about 10,000 turns of very fine wire. Lead (C) is to insulated terminal of breaker points. Lead (D) is to ground. Spark plug (high tension wire) attaches to terminal (T).

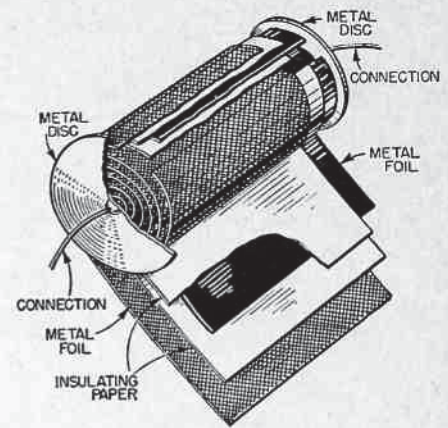

Fig. CS18 — View showing construction of typical condenser. One connection is usually made to the metal housing of the condenser and is grounded to the magneto base plate through the condenser mounting strap (3—Fig. CS17).

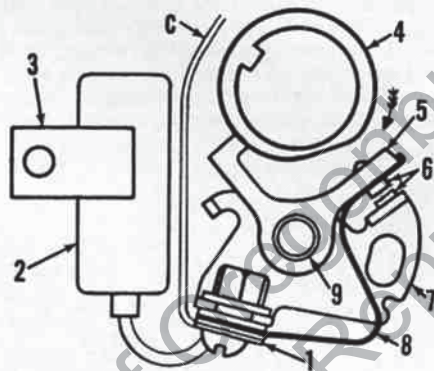

Fig. CS17 — Typical flywheel magneto breaker point unit. Cam (4) is driven by engine crankshaft. Breaker arm spring (8) connects insulated contact point on breaker arm (5) to terminal (1).

- C. Lead to primary coil
- 1. Insulated terminal
- 2. Condenser
- 3. Condenser ground (mounting) strap
- 4. Breaker cam
- 5. Breaker arm
- 6. Contact points
- 7. Breaker base
- 8. Spring
- 9. Pivot pins

parallel with the breaker points as shown in Fig. CS19.

The basic function of the condenser is to absorb the flow of current in the primary ignition circuit to prevent the current from arcing across the opening breaker points.

HOW IGNITION SPARK IS PRODUCED.

The following explanation of how the ignition spark is produced is based upon the previous paragraphs in this section. By knowing the basic principles of electromagnetic induction and electro-magnetic fields, and by being able to identify the component parts of the magneto, magneto operation can be more easily understood.

In Fig. CS13, a cross-sectional view of a typical engine flywheel (magneto rotor) is shown. The arrows indicate lines of force (flux) of the permanent magnets carried by the flywheel. As indicated by the arrows, direction of force of the magnetic field is from the north pole (N) of the left magnet to the south pole (S) of the right magnet.

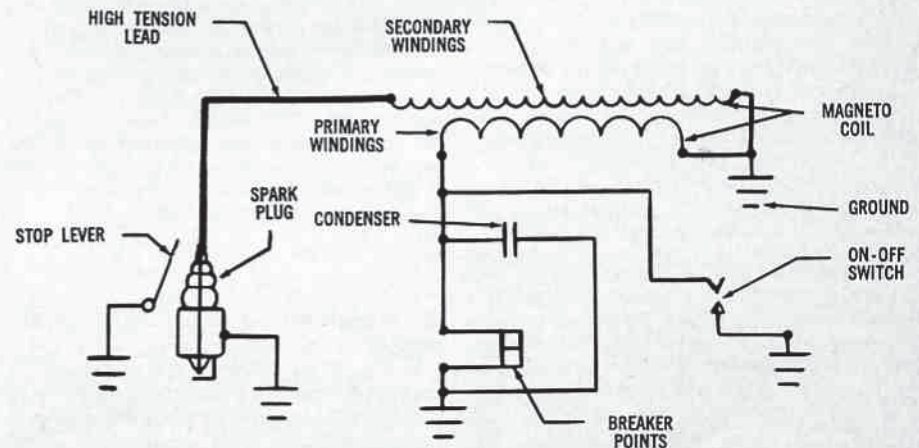

Fig. CS19 — Typical wiring diagram for conventional flywheel type magneto. An on-off switch to stop the engine may be attached to the magneto primary circuit to ground out the system, or a stop lever may be used to ground out the center electrode of the spark plug.

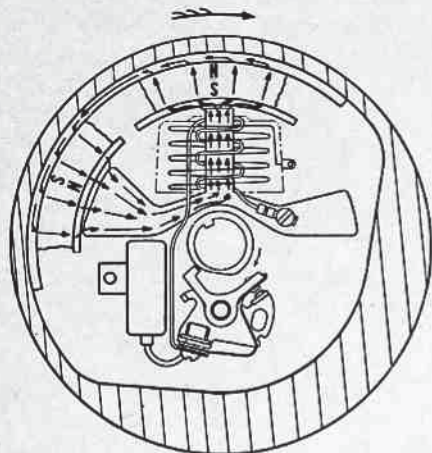

Fig. CS20—View showing flywheel turned to a position so that lines of force of the permanent magnets are concentrated in the left and center core legs and are interlocking the coil windings.

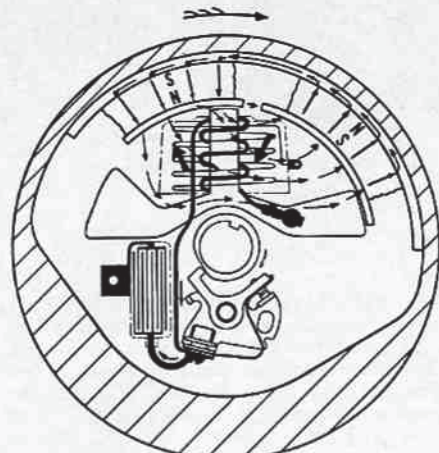

Fig. CS22—The flywheel magnets have now turned slightly past position shown in Fig. CS21 and rate of movement of lines of magnetic force cutting through coil windings is at maximum. At this instant, the breaker points are opened by the cam and flow of current in primary circuit is being absorbed by the condenser, bringing flow of current to a quick, controlled stop. Refer now to Fig. CS23.

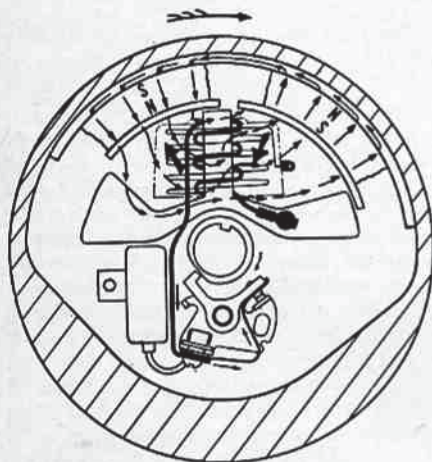

Fig. CS21—View showing flywheel turned to a position so that lines of force of the permanent magnets are being withdrawn from left and center core legs and are being attracted by center and right core legs. While this event is happening, the lines of force are cutting up through the coil windings section between left and center legs and are cutting down through section between the right and center legs as indicated by the heavy black arrows. The breaker points are now closed by the cam and a current is induced in the primary ignition circuit as lines of force cut through the coil windings.

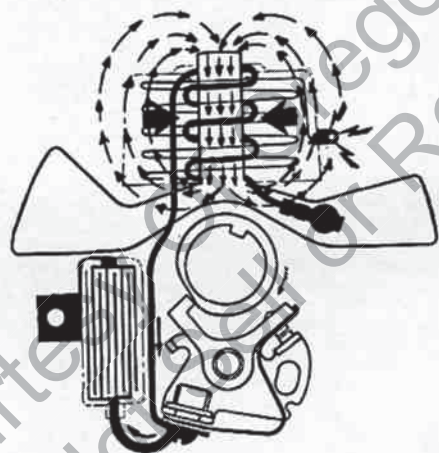

Fig. CS23—View showing magneto ignition coil, condenser and breaker points at same instant as illustrated in Fig. CS22; however, arrows shown above illustrate lines of force of the electro-magnetic field established by current in primary coil windings rather than the lines of force of the permanent magnets. As the current in the primary circuit ceases to flow, the electro-magnetic field collapses rapidly, cutting the coil windings as indicated by heavy arrows and inducing a very high voltage in the secondary coil winding resulting in the ignition spark.

Figs. CS20, CS21, CS22 and CS23 illustrate the operational cycle of the flywheel type magneto. In Fig. CS20, the flywheel magnets have moved to a position over the left and center legs of the armature (ignition coil) core. As the magnets moved into this position, their magnetic field was attracted by the armature core as illustrated in Fig. CS14 and a potential voltage (emf) was induced in the coil windings. However, this emf was not sufficient to cause current to flow across the spark plug electrode gap

in the high tension circuit and the points were open in the primary circuit.

In Fig. CS21, the flywheel magnets have moved to a new position to where their magnetic field is being attracted by the center and right legs of the armature core, and is being withdrawn from the left and center legs. As indicated by the heavy black arrows, the lines of force are cutting up through the section of coil windings be-

tween the left and center legs of the armature and are cutting down through the coil windings section between the center and right legs. If the right hand rule, as explained in a previous paragraph, is applied to the lines of force cutting through the coil sections, it is seen that the resulting emf induced in the primary circuit will cause a current to flow through the primary coil windings and the breaker points which have now been closed by action of the cam.

At the instant the movement of the lines of force cutting through the coil winding sections is at the maximum rate, the maximum flow of current is obtained in the primary circuit. At this time, the cam opens the breaker points interrupting the primary circuit and, for an instant, the flow of current is absorbed by the condenser as illustrated in Fig. CS22. An emf is also induced in the secondary coil windings, but the voltage is not sufficient to cause current to flow across the spark plug gap.

The flow of current in the primary windings created a strong electromagnetic field surrounding the coil windings and up through the center leg of the armature core as shown in Fig CS23. As the breaker points were opened by the cam, interrupting the primary circuit, this magnetic field starts to collapse cutting the coil windings as indicated by the heavy black arrows. The emf induced in the primary circuit would be sufficient to cause a flow of current across the opening breaker points were it not for the condenser absorbing the flow of current and bringing it to a controlled stop. This allows the electromagnetic field to collapse at such a rapid rate to induce a very high voltage in the coil high tension or secondary windings. This voltage, in the order of 15,000 to 25,000 volts, is sufficient to break down the resistance of the air gap between the spark plug electrodes and a current will flow across the gap. This creates the ignition spark which ignites the compressed fuel-air mixture in the engine cylinder.

SOLID STATE (BREAKERLESS) MAGNETO IGNITION SYSTEM

The solid state (breakerless) magneto ignition system operates somewhat on the same basic principles as the conventional type flywheel magneto previously described. The main difference is that the breaker contact points are replaced by a solid state electronic Gate Controlled Switch (GCS) which has no moving parts. Since, in a conventional system, the breaker points are closed over a longer period of crankshaft rotation than is the "GCS", a diode has been added to the circuit to provide the same characteristics as closed breaker points.

BASIC OPERATING PRINCIPLES. The same basic principles for electro-magnetic induction of electricity and formation of magnetic fields by electrical current as outlined for the conventional flywheel type magneto also apply to the solid state magneto. Thus, the principles of the different components (diode and GCS) will complete the operating principles of the solid state magneto.

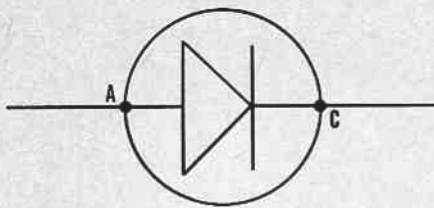

Fig. CS24—In a diagram of an electrical circuit, the diode is represented by the symbol shown above. The diode will allow current to flow in one direction only (from anode "A" to cathode "C" terminal of diode).

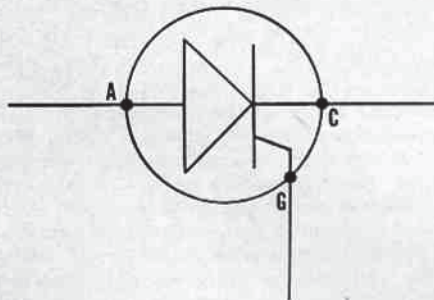

Fig. CS24A—The symbol used for a Gate Controlled Switch (GCS) in an electrical diagram is shown above. The GCS will allow current to flow from anode (A) terminal to cathode (C) terminal when "turned on" by a positive electrical charge at gate (G) terminal. A negative electrical charge at gate (G) terminal will turn off the GCS.

DIODE OPERATING PRINCIPLES. The diode is represented in wiring diagrams by the symbol as shown in Fig. CS24. Although the principle of diode operation is beyond the scope of this manual, it is sufficient to say that it is an electronic device that will permit passage of electrical current in one direction only. In electrical schematic diagrams, the arrow part of the symbol illustrates the direction which current can flow through the diode.

GATE CONTROLLED SWITCH (GCS). The symbol shown in Fig. CS24A is used to represent the gate controlled switch (GCS) in wiring diagrams. As with the diode, discussion of the GCS is beyond the scope of this manual. However, its action in an electrical circuit is as follows:

The GCS acts as a switch to permit passage of electrical current in the direction indicated by the arrow portion of the symbol (Fig. CS24A) when in "ON" state and will not permit electric current to flow when in "OFF" state. The GCS can be turned "ON" by a positive surge of electricity at the gate (G) terminal and will remain "ON" as long as current remains positive at the gate terminal or as long as current is flowing through the GCS from anode (A) terminal to cathode (C) terminal. The GCS can be turned "OFF" with a negative surge of electricity at the gate (G) terminal or will go to "OFF" state if current stops flowing through the switch from anode (A) to cathode (C).

HOW IGNITION SPARK IS PRODUCED. The basic components and wiring diagram for the solid state (breakerless) magneto are

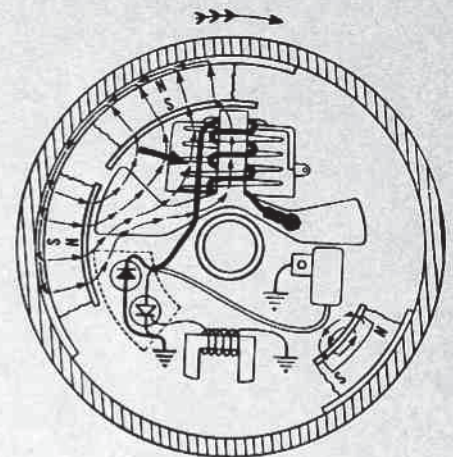

Fig. CS24C—View showing rotor of solid state magneto at instant in rotation where lines of force of ignition coil magnets are being drawn into left and center legs of magneto armature. The diode (see Fig. CS24) acts as a closed set of breaker points in completing the primary ignition circuit at this time, thus preventing an unwanted (maverick) spark which could occur at this time. Refer next to Fig. CS24D.

shown schematically in Fig. CS24C, the magneto rotor (flywheel) is turning and the ignition coil magnets have just moved into position so that their lines of force are cutting the ignition coil windings and producing a negative surge of current in the primary windings. The diode (see Fig. CS24B) allows current to flow as indicated by arrow and action is same as conventional magneto with breaker contact points closed.

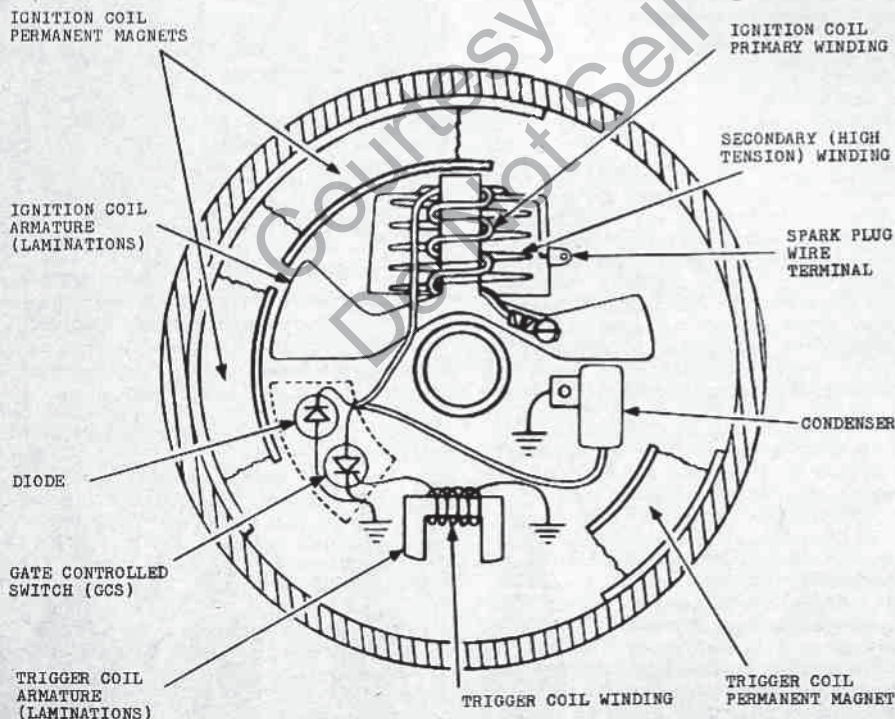

Fig. CS24B — Schematic diagram of solid state (breakerless) flywheel magneto. The diagram is drawn to follow the schematic drawings of a conventional type magneto as shown in Figs. CS20, CS21, CS22 and CS23. Refer to Figs. CS24 and CS24A for diode and Gate Controlled Switch (GCS) symbols. Refer to Figs. CS24C, CS24D and CS24E for schematic views of magneto operating cycle.

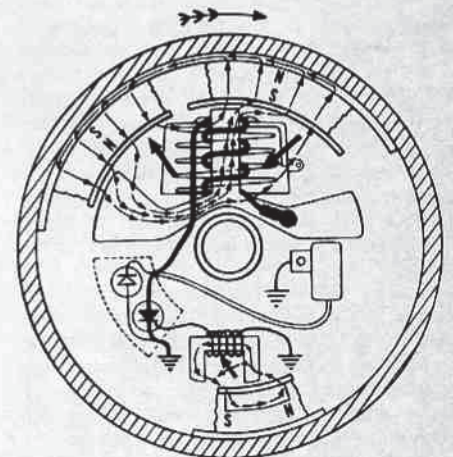

Fig. CS24D—Refer to Fig. CS24C. Magneto rotor has now turned into position so that lines of force of ignition coil magnets are pulling out of armature left leg and are being pulled into the right leg. Thus, lines of magnetic force are cutting ignition coil windings on both sides of center leg inducing a strong voltage. The trigger coil magnets have also moved to a position where lines of magnetic force are being pulled into the trigger coil armature creating a positive charge in the lead to the Gate Controlled Switch (GCS), thus "turning on" the switch for passage of current in the ignition primary circuit. Refer now to Fig. CS24E.

to quickly collapse creating an ignition spark as illustrated in Fig. CS23 for the conventional type flywheel magneto.

SOLID STATE (BREAKERLESS) CAPACITOR DISCHARGE IGNITION SYSTEM

The capacitor discharge (CD) ignition system uses a permanent magnet rotor to induce a current in a coil, but unlike the conventional flywheel magneto and solid state (breakerless) magneto described previously, the current is stored in a capacitor (condenser), then the stored current is discharged through a transformer coil to create the ignition spark, whereas the other type magnetos utilize a collapsing magnetic field passing through the ignition coil to provide current for the ignition spark.

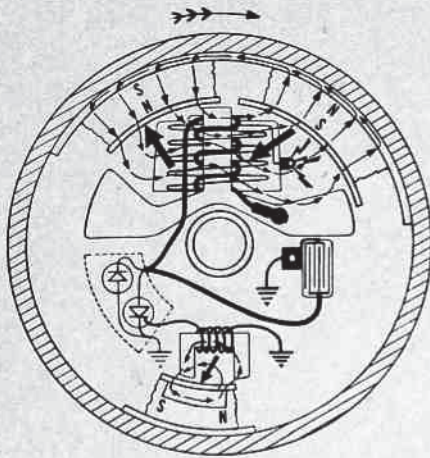

Fig. CS24E—Refer first to Figs. CS24C and CS24D. The ignition coil magnets have now moved to a position so that their lines of force are cutting the ignition coil windings at a maximum rate. At this same instant, movement of the trigger coil magnets is pulling lines of force away from the trigger coil armature thus creating a negative charge in the coil lead to the GCS gate terminal. This "turns off" the GCS and interrupts the primary ignition circuit just as would breaker points opening in a conventional magneto. As the primary current is interrupted at its peak, the current is brought to a quick stop by the condenser and a very high voltage is induced in the ignition coils. Refer to Fig. CS23 regarding the collapsing electro-magnetic field surrounding the ignition coil.

In Fig. CS24D, the magneto rotor continues to turn and the ignition coil magnets are in the position to cause their lines of force to cut the coil windings on both sides of the center leg of armature as indicated by the arrows. At the same time, the trigger coil magnet has moved into position to allow its lines of force to cut the trigger coil windings inducing a current which is positive at the GCS gate (G) terminal (see Fig. CS24A) turning the GCS to "ON" state. Thus, the electrical current induced into the ignition coil primary coil windings can flow through the "ON" GCS as though in a conventional magneto with breaker points closed.

In Fig. CS24E, the magneto rotor has turned to a position so that the lines of force of the ignition coil permanent magnets are cutting the ignition coil windings at the maximum rate, thus the current in the primary windings is at its peak value. The trigger coil magnet is so located on the magneto rotor that at the time the ignition coil magnets are at the position to produce the highest rate of flux movement through the ignition coil, the lines of flux of the trigger coil magnet are cutting through the trigger coil windings in the direction to produce a negative charge of electricity at the GCS gate (G) terminal. This negative charge of electricity turns the GCS to "OFF" state, thus acting the same as the breaker contact points opening at peak ignition coil primary winding current. The condenser absorbs the primary current bringing it to a quick controlled stop causing the electro-magnetic field surrounding the ignition coil

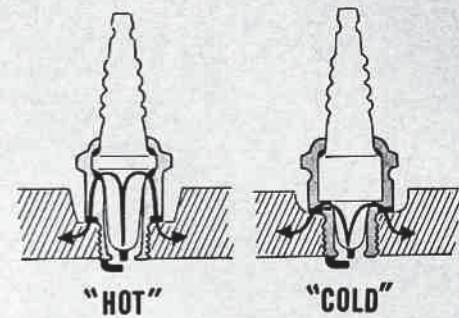

Fig. CS27—Spark plug tip temperature is controlled by the length of the path heat must travel to reach the cooling surface of the engine cylinder head.

distance of the air gap is increased. Compression pressures are highest at full throttle and relatively slow engine speeds, therefore, high voltage requirements or a lack of available secondary voltage most often shows up as a miss during maximum acceleration from a slow engine speed. There are many different types and sizes of spark plugs which are designed for a number of specific requirements.

THREAD SIZE. The threaded, shell portion of the spark plug and the attaching hole in the cylinder are manufactured to meet certain industry established standards. The diameter is referred to as "Thread Size." Those commonly used are: 10 mm, 14 mm, 18 mm, 3/8 inch and 1/2 inch pipe. The 14 mm plug is almost universal for chain saw engine use.

REACH. The length of thread, and the thread depth in cylinder head or wall are also standardized throughout the industry. This dimension is measured from gasket seat of head to cylinder end of thread. See Fig. CS26. Four different reach plugs commonly used are: 3/8-inch, 7/16-inch, 1/2-inch and 3/4-inch. The first two mentioned are the ones commonly used in chain saw engines.

HEAT RANGE. During engine operation, part of the heat generated during combustion is transferred to the spark plug, and from the plug to the cylinder through the shell threads and gasket. The operating temperature of the spark plug plays an

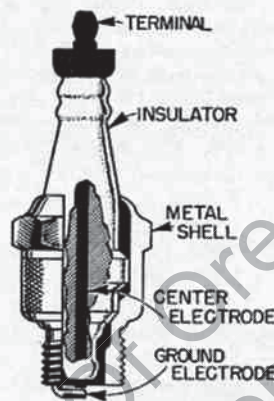
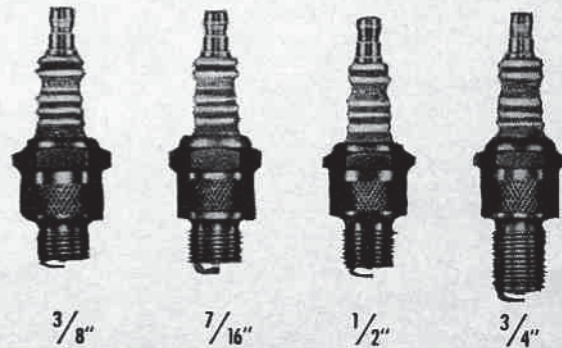

Fig. CS25 — Cross sectional view of spark plug showing construction and nomenclature.

SPARK PLUG

In any spark ignition engine, the spark plug (See Fig. CS25) provides the means for igniting the compressed fuel-air mixture in the cylinder. Before an electric charge can move across an air gap, the intervening air must be charged with electricity, or ionized. If the spark plug is properly gapped and the system is not shorted, not more than 7,000 volts may be required to initiate a spark. Higher voltage is required as the spark plug warms up, or if compression pressures or the

Fig. CS26 — Various "reaches" of plugs available. Chain saw engines normally use a 3/8-inch reach spark plug. A 3/8-inch reach plug measures 3/8-inch from firing end of shell to gasket surface of shell.



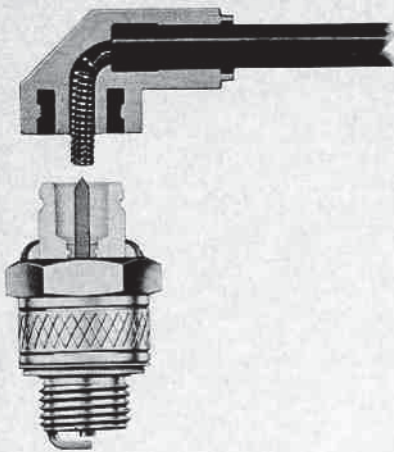

Fig. CS29 — Cut-away view of special "shorty" type spark plug and terminal available for chain saw engines. Refer to Fig. CS29A for a second type special plug.

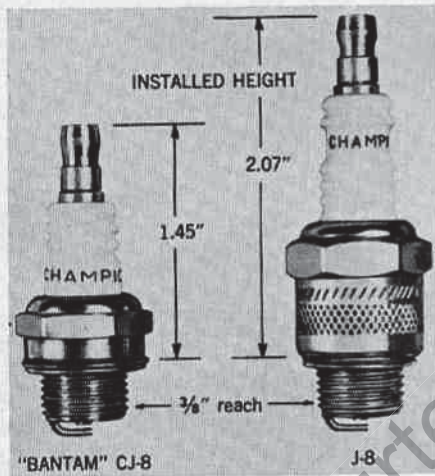

Fig. CS29A—View showing special "bantam" type spark plug as compared with regular type spark plug of same heat range. Refer also to Fig. CS29 for view of special "shorty" type plug.

important part in engine operation. If too much heat is retained by the plug, the fuel-air mixture may be ignited by contact with the heated surface before the ignition spark occurs. If not enough heat is retained, partially burned combustion products (soot, carbon and oil) may build up on the plug tip resulting in "fouling" or shorting out of the plug. If this happens, the secondary current is dissipated uselessly as it is generated instead of bridging the plug gap as a useful spark, and the engine will misfire.

The operating temperature of the plug tip can be controlled, within limits, by altering the length of the path the heat must follow to reach the threads and gasket of the plug. Thus, a plug with a short, stubby insulator around the center electrode will run cooler than one with a long, slim insulator. Refer to Fig. CS27. Most plugs in the more popu-

lar sizes are available in a number of heat ranges which are interchangeable within the group. The proper heat range is determined by engine design and the type of service. Refer to SPARK PLUG SERVICING, in SERVICE FUNDAMENTALS section, for additional information on spark plug selection.

SPECIAL TYPES. Sometimes, engine design features or operating conditions call for special plug types designed for a particular purpose. Of special interest when dealing with chain saw engines are the "shorty" type plug shown in Fig. CS29, and the "bantam" type plug shown in Fig. CS29A.

SERVICE FUNDAMENTALS

IGNITION SYSTEM

In servicing a chain saw ignition system, the mechanic is concerned with trouble shooting, service adjustments and testing magneto components. The following paragraphs outline the basic steps in servicing a flywheel type magneto. Refer to the appropriate chain saw engine section for adjustment and test specifications for a particular engine.

TROUBLE SHOOTING

If the chain saw engine will not start and malfunction of the ignition system is suspected, make the following checks to find cause of trouble.

Check to be sure that the ignition switch (if chain saw is so equipped) is in the "On" or "Run" position and that the insulation on the wire leading to the ignition switch is in good condition. The switch can be checked with the timing and test light as shown in Fig. CS30. Disconnect the lead from the switch and attach one clip of the test light to the switch terminal and the other clip to the chain saw frame or engine. The light should go on when the switch is in the "Off" or "Stop" position, and should go off when the switch is in the "On" or "Run" position.

Inspect the high tension (spark plug) wire for worn spots in the insulation or breaks in the wire. Frayed or worn insulation can be repaired temporarily with plastic electrician's tape.

If no defects are noted in the ignition switch or ignition wires, remove and inspect the spark plug as outlined in the SPARK PLUG SERVICING section. If the spark plug is fouled or is in questionable condition, connect a spark plug of known quality to the high tension wire, ground the base of the spark plug to engine and turn engine rapidly with the starter. If the spark across the electrode gap of the spark plug is a bright blue, the magneto can be considered in satisfactory condition. **NOTE:** Some engine manufacturers specify a certain type spark plug and a specific test gap. Refer to appropriate engine service section; if no specific spark plug type or electrode gap is recommended for test purposes, use spark plug type and electrode gap recommended for engine make and model. If the spark across the gap of the test plug is weak or orange colored, or no spark occurs as engine is cranked, magneto should be serviced as outlined in the following paragraphs.

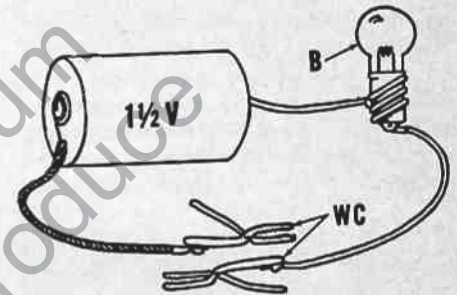

Fig. CS30—A static timing light can be made from a flashlight battery, a bulb (B), two wire clips (WC) and short pieces of insulated wire. Bulb should light when clips are touched together. Refer to Fig. CS30A.

MAGNETO ADJUSTMENTS

BREAKER CONTACT POINTS. Adjustment of the breaker contact points affects both ignition timing and magneto edge gap. Therefore, the breaker contact point gap should be carefully adjusted according to engine manufacturer's specifications. Before adjusting the breaker contact gap, inspect contact points and renew if condition of contact surfaces is questionable. It is sometimes desirable to check the condition of points as follows: Disconnect the condenser and primary coil leads from the breaker point terminal. Attach one clip of a test light (See Fig. CS30) to the breaker point terminal and the other clip of the test light to magneto ground. The light should be out when contact points are open and should go on when the engine is turned to close the breaker contact points. If the light stays on when points are open, insulation of breaker contact arm or condenser is defective. If light does not go on when points are closed, contact surfaces are dirty, oily or are burned.

Adjust breaker point gap as follows unless manufacturer specifies adjusting breaker gap to obtain correct ignition timing. First, turn engine so that points are closed to be sure that the contact surfaces are in alignment and seat squarely. Then, turn engine so that breaker point opening is maximum and adjust breaker gap to manufacturer's specification. A wire type feeler gage is recommended for checking and adjusting the breaker contact gap. Be sure to recheck gap after tightening breaker point base retaining screws.

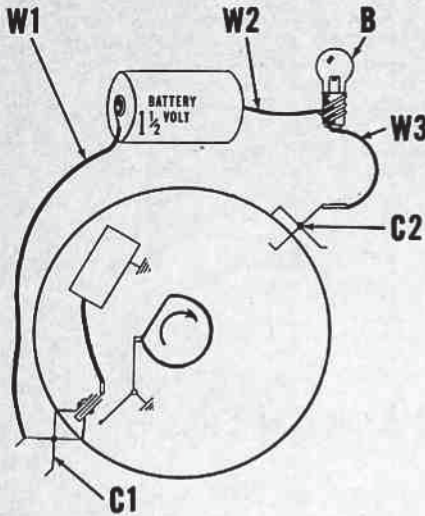

Fig. CS30A—When connecting timing light (see Fig. CS30), first disconnect primary coil wire from breaker point terminal, then connect one wire clip (C1) to terminal and other clip (C2) to magneto back plate or engine. Bulb should be out when points are open and light when points close.

IGNITION TIMING. On some engines, ignition timing is non-adjustable and a certain breaker point gap is specified. On other engines, timing is adjustable by changing the position of the magneto stator plate (See Fig. CS31) with a specified breaker point gap or by simply varying the breaker point gap to obtain correct timing. Ignition timing is usually specified either in degrees of engine (crankshaft) rotation or in piston travel before the piston reaches top dead center position. In some instances, a specification is given for ignition timing even though the timing may be non-adjustable; if a check reveals timing is incorrect on these engines, it is an indication of incorrect breaker point adjustment or excessive wear of breaker cam. Also, on some engines, it may indicate that a wrong breaker cam has been installed or that the cam has been installed in a reversed position on engine crankshaft.

Some engines may have a timing mark or flywheel locating pin to locate the flywheel at proper position for the ignition spark to occur (breaker points begin to open). If not, it will be necessary to measure piston travel as illustrated in Fig. CS32 or install a degree indicating device on the engine crankshaft.

A timing light as shown in Fig. CS30 is a valuable aid in checking or adjusting engine timing. After disconnecting the ignition coil lead from the breaker point terminal, connect the leads of the timing light as shown. If timing is adjustable by moving the magneto stator plate, be sure that the breaker point gap is adjusted as specified. Then, to check timing, slowly turn engine in normal direction of rotation past the point at which ignition spark should occur. The timing light should be on, then go out (breaker points open) just as the correct timing location is passed. If not, turn engine to proper timing location and adjust timing by relocating the magneto stator plate or varying the breaker contact gap as specified by engine manufacturer. Loosen the screws retaining the stator plate or breaker points and adjust position of stator plate

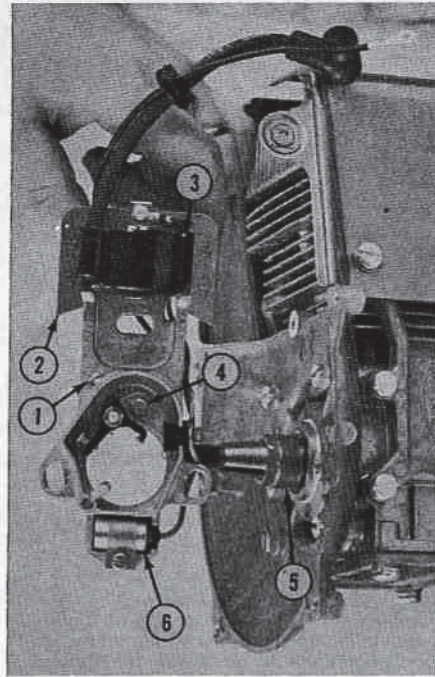

Fig. CS31 — On some chain saw engines, the magneto stator plate mounting holes are slotted as shown so that ignition timing can be adjusted by relocating position of stator plate.

- 1. Stator plate
- 2. Armature core
- 3. Ignition coil
- 4. Breaker point base
- 5. Breaker cam
- 6. Condenser

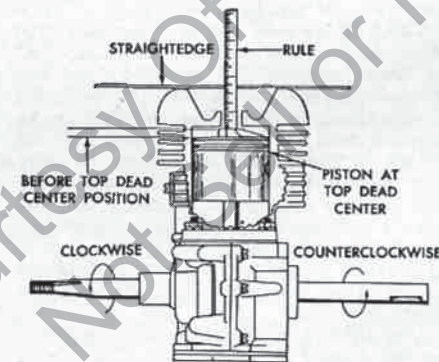

Fig. CS32 — Where timing is specified as measurement of piston travel, measurement can be made as illustrated. Use of a dial indicator instead of ruler will give more exact measurement. Some manufacturers provide a timing gage that can be screwed into spark plug hole or a gage that can be attached to crankshaft.

or points so that points are closed (timing light is on). Then, slowly move adjustment until timing light goes out (points open) and tighten the retaining screws. Recheck timing to be sure adjustment is correct.

ARMATURE AIR GAP. To fully concentrate the magnetic field of the flywheel magnets within the armature core, it is necessary that the flywheel magnets pass as closely to the armature core as possible without danger of metal to metal contact. The clearance between the flywheel magnets and the legs of the armature core is called the armature air gap.

On magnetos where the armature and

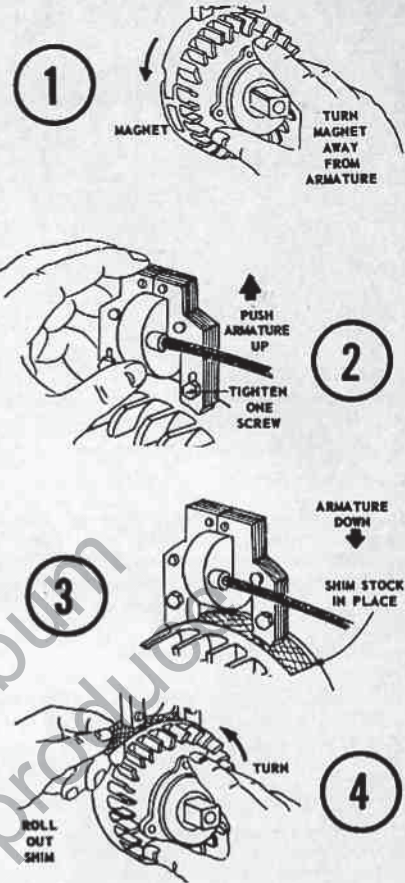

Fig. CS33 — Views showing adjustment of armature air gap when armature is located outside flywheel. Refer to Fig. CS34 for engines having armature located inside (under) flywheel.

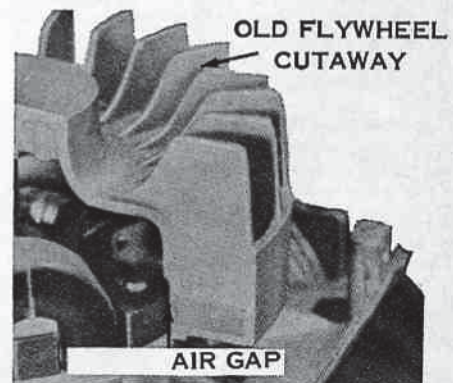

Fig. CS34 — Where armature core and ignition coil are located inside of flywheel, an old discarded flywheel can be cut away as shown to provide air gap adjustment fixture.

high tension coil are located outside of the flywheel rim, adjustment of the armature air gap is made as follows: Turn the engine so that the flywheel magnets are located directly under the legs of the armature core and check the clearance between the armature core and flywheel magnets. If the measured clearance is not within manufacturers specifications, loosen the armature core mounting screws and place shims of

thickness equal to minimum air gap specification between the magnets and armature core (Fig. CS33). The magnets will pull the armature core against the shim stocks. Tighten the armature core mounting screws, remove the shim stock and turn the engine through several revolutions to be sure the flywheel does not contact the armature core.

Where the armature core is located under or behind the flywheel, the following methods may be used to check and adjust armature air gap: On some engines, slots or openings are provided in the flywheel through which the armature air gap can be checked. Some engine manufacturers provide a cut-away flywheel that can be installed temporarily for checking the armature air gap. A test flywheel can be made out of a discarded flywheel (See Fig. CS34), or out of a new flywheel if service volume on a particular engine warrants such expenditure. Another method of checking the armature air gap is to remove the flywheel and place a layer of plastic tape equal to the minimum specified air gap over the legs of the armature core. Reinstall flywheel and turn engine through several revolutions and remove flywheel; no evidence of contact between the flywheel magnets and plastic tape should be noticed. Then cover the legs of the armature core with a layer of tape of thickness equal to the maximum specified air gap; then, reinstall flywheel and turn engine through several revolutions. Indication of the flywheel magnets contacting the plastic tape should be noticed after the flywheel is again removed. If the magnets contact the first thin layer of tape applied to the armature core legs, or if they do not contact the second thicker layer of tape, armature air gap is not within specifications and should be adjusted. NOTE: Before loosening armature core mounting screws, scribe a mark on mounting plate against edge of armature core so that adjustment of air gap can be gaged.

In some instances, it may be necessary to slightly enlarge the armature core mounting holes before proper air gap adjustment can be made.

MAGNETO EDGE GAP. The point of maximum acceleration of the movement of the flywheel magnetic field through the high tension coil (and therefore, the point of maximum current induced in the primary coil windings) occurs when the trailing edge of the flywheel magnet is slightly past the left hand leg of the armature core as shown in Fig. CS21. The exact point of maximum primary current is determined by using electrical measuring devices, the distance between the trailing edge of the flywheel magnet and the leg of the armature core at this point is measured and becomes a service specification. This distance, which is stated either in thousandths of an inch or in degrees of flywheel rotation, is called the Edge Gap or "E" Gap.

For maximum strength of the ignition spark, the breaker points should just start to open when the flywheel magnets are at the specified edge gap position. Usually, edge gap is non-adjustable and will be maintained at the proper dimension if the contact breaker points are adjusted to the recommended gap and the correct breaker cam is installed. However, magneto edge gap can change (and spark intensity thereby reduced) due to the following:

- a. Flywheel drive key sheared
- b. Flywheel drive key worn (loose)

- c. Keyway in flywheel or crankshaft worn (oversized)
- d. Loose flywheel retaining nut which can also cause any above listed difficulty
- e. Excessive wear on breaker cam
- f. Breaker cam loose on crankshaft
- g. Excessive wear on breaker point rubbing block so that points cannot be properly adjusted.

SPARK PLUG SERVICING

ELECTRODE GAP. The spark plug electrode gap (Refer to Fig. CS38) should be adjusted by bending the ground electrode. The recommended gap is listed in the SPARK PLUG paragraph in MAINTENANCE section for the individual motor.

CLEANING AND ELECTRODE CONDITIONING. Spark plugs are most usually cleaned by abrasive action commonly referred to as "sand blasting." Actually, ordinary sand is not used, but a special abrasive which is nonconductive to electricity even when melted, thus the abrasive cannot short out the plug current. Extreme care should be used in cleaning the plugs after sand blasting, however, as any particles of abrasive left on the plug may cause damage to piston rings, piston or cylinder walls.

After plug is cleaned by abrasive, and before gap is set, the electrode surfaces between the grounded and insulated electrodes should be cleaned and returned as nearly as possible to original shape by filing with a point file. Failure to properly dress the points can result in high secondary voltage requirements, and misfire of the plugs.

PLUG APPEARANCE DIAGNOSIS. The appearance of a spark plug will be altered by use, and an examination of the plug tip can contribute useful information which may assist in obtaining better spark plug life. It must be remembered that the contributing factors differ in two-cycle and four-cycle engine operation and, although the appearance of two spark plugs may be similar, the corrective measures may depend on whether the engine is of two-cycle or four-cycle design. Fig. CS40 to Fig. CS45 are provided by Champion Spark Plug Company to illustrate typical observed conditions in Two-Cycle engines. Listed also are the probable causes and suggested corrective measures.

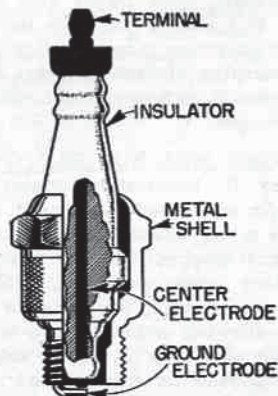

Fig. CS38 — Cross sectional view of spark plug showing construction and nomenclature.

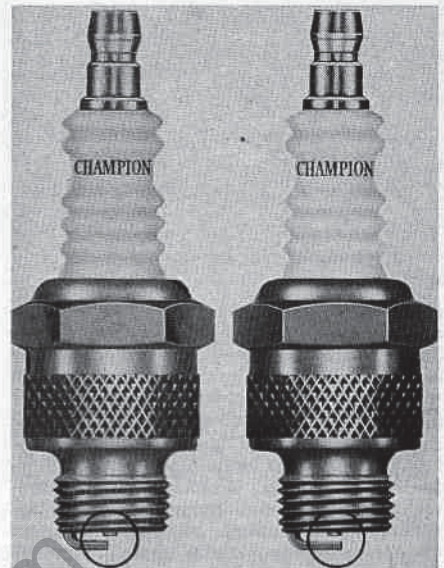

Fig. CS39 — The two-cycle plug (left) differs from conventional plug in that the grounded electrode is shortened to minimize carbon fouling.



Fig. CS40 — Two cycle engine plug of correct heat range. Insulators light tan to grey with few deposits. Electrodes not burned.

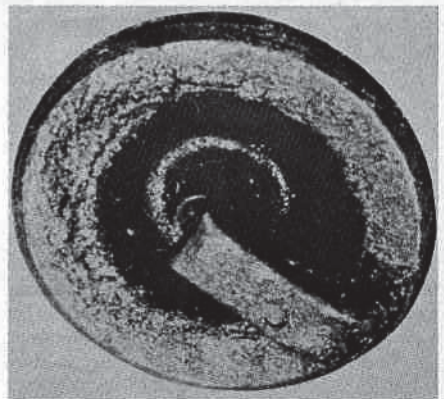

Fig. CS41 — Damp or wet black carbon coating over entire firing end of plug. Could be caused by rich carburetor mixture, too much oil in fuel, or low ignition voltage. Could also be caused by incorrect heat range (too cold) for operating conditions. Correct the defects or install a hotter plug.

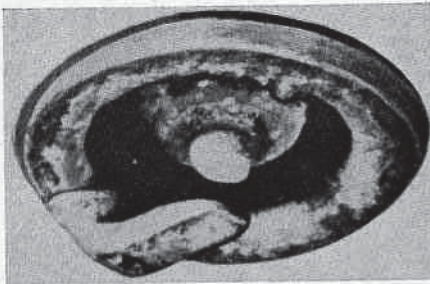

Fig. CS42 — Electrodes badly eroded, deposits white or light gray and gritty, insulator has "blistered" appearance. Could be caused by lean carburetor mixture, fast timing, overloading, or air intake screen and engine cooling fins blocked with sawdust or other debris. Could also be caused by incorrect heat range (too hot) for operating conditions. Check timing, carburetor adjustment, cooling system. If timing, carburetor adjustment, cooling system and engine speed are correct, install a colder plug.



Fig. CS44 — Core bridging from center electrode to shell. Fused deposits sometimes have the appearance of tiny beads or glasslike bubbles. Caused by excessive combustion chamber deposits which in turn could be the result of; excessive carbon from prolonged usage; use of improper oil or incorrect fuel-oil ratio.



Fig. CS43 — Gray, metallic aluminum deposits on plug. (Seldom encountered). Piston damage due to pre-ignition. Overhaul motor and determine cause of pre-ignition.

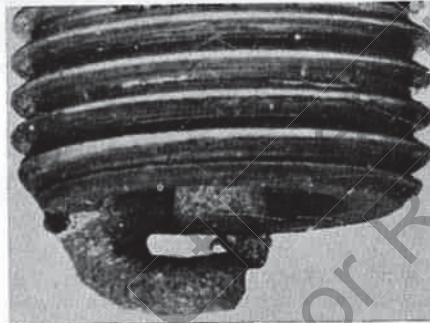

Fig. CS45 — Gap bridging. Usually results from the same causes outlined in Fig. CS44.

CARBURETOR SERVICING

TROUBLE SHOOTING. Normally encountered difficulties resulting from carburetor malfunction, along with possible causes of difficulty, are as follows:

A. CARBURETOR FLOODS. Could be caused by: (1), dirt or foreign particles preventing inlet fuel needle from seating; (2), diaphragm lever spring not seated correctly on diaphragm lever; or (3), improperly installed metering diaphragm. Also, when fuel tank is located above carburetor, flooding can be caused by leaking fuel pump diaphragm.

B. ENGINE RUNS LEAN. Could be caused by: (1), fuel tank vent plugged; (2) leak in fuel line or fittings between fuel tank and carburetor; (3), filter screen in carburetor or filter element in fuel pick-up head plugged; (4), fuel orifice plugged; (5), hole in fuel metering diaphragm; (6), metering lever not properly set; (7), dirt in carburetor fuel channels or pulse channel to engine crankcase plugged; or (8), leaky gaskets between carburetor and crankcase intake port. Also, check for leaking crankshaft seals, porous or cracked crankcase or other cause for air leak into crankcase. When fuel tank or fuel level is below carburetor, lean operation can be

caused by hole in fuel pump diaphragm or damaged valve flaps on pump diaphragm. On Walbro series SDC carburetor with diaphragm type accelerating pump, a leak in accelerating pump diaphragm will cause lean operating.

C. ENGINE WILL NOT ACCELERATE SMOOTHLY. Could be caused by: (1), inoperative accelerating pump, on carburetors so equipped, due to plugged channel, leaking diaphragm, stuck piston, etc.; (2), idle or main fuel mixture too lean on models without accelerating pump; (3), incorrect setting of metering diaphragm lever; (4), diaphragm gasket leaking; or (5), main fuel orifice plugged.

D. ENGINE WILL NOT IDLE. Could be caused by: (1), incorrect adjustment of idle fuel and/or idle speed stop screw; (2), idle discharge or air mixture ports clogged; (3), fuel channel clogged; (4), dirty or damaged main orifice check valve; (5), Welch (expansion) plug covering idle ports not sealing properly allowing engine to run with idle fuel needle closed; or (6), throttle shutter not properly aligned on throttle shaft causing fast idle.

E. ENGINE RUNS RICH. Could be caused by: (1), plug covering main nozzle orifice

not sealing; or (2), when fuel level is above carburetor, leak in fuel pump diaphragm.

SERVICE PROCEDURES. General service procedures for overhauling and/or cleaning diaphragm type carburetors are outlined in the following paragraphs:

The bulk of carburetor service consists of cleaning, inspection and adjustment. After considerable service it may become necessary to overhaul the carburetor and renew worn parts to restore original operating efficiency. Although carburetor condition affects engine operating economy and power, ignition and engine compression must also be considered to determine and correct causes of poor performance.

Before dismantling carburetor for cleaning or overhaul, clean all external surfaces and remove accumulated dirt and grease. Dismantle carburetor and note any discrepancies to assure correction during overhaul. Thoroughly clean all parts and inspect for damage or wear. Wash jets and passages and blow clear with clean, dry compressed air. **NOTE:** Do not blow compressed air through main nozzle orifice screen on Walbro series SDC carburetor as this will damage the rubber check valve; renew nozzle screen/seat and check valve if in doubt. A special check valve repair kit and installation tool are available. Do not use a drill or wire to clean jets as the possible enlargement of calibrated hole will disturb operating balance. The measurement of jets to determine the extent of wear is difficult and new parts are usually installed to assure satisfactory results.

Carburetor manufacturers provide for many of their models an assortment of gaskets and other parts usually needed to do a correct job of cleaning and overhaul. These assortments are usually catalogued as Gasket Kits and Overhaul Kits respectively.

Check the fit of throttle and choke valve shafts. Excessive clearance will cause improper valve plate seating and will permit dust or grit to be drawn into the engine. Air leaks at throttle shaft bores due to wear will upset carburetor calibration and contribute to uneven engine operation. Rebush valve shaft holes where necessary and renew dust seals. If rebushing is not possible, renew the body part supporting the shaft. Inspect throttle and choke valve plates for proper installation and condition.

Power or idle adjustment needles must not be worn or grooved. Check condition of needle seal packing or "O" ring and renew packing or "O" ring if necessary.

Reinstall or renew jets, using correct size listed for specific model. Adjust power and idle settings as described for specific carburetors in engine service section of manual.

It is important that the carburetor bore at the idle discharge ports and in the vicinity of the throttle valve be free of deposits. A partially restricted idle port will produce a "flat spot" between idle and mid-range rpm. This is because the restriction makes it necessary to open the throttle wider than the designed opening to obtain proper idle speed. Opening the throttle wider than the design specified amount will uncover more of the port than was intended in the calibration of the carburetor. As a result an insufficient amount of the port will be available as a reserve to cover the transition period (idle to the mid-range rpm) when the high speed system begins to function.

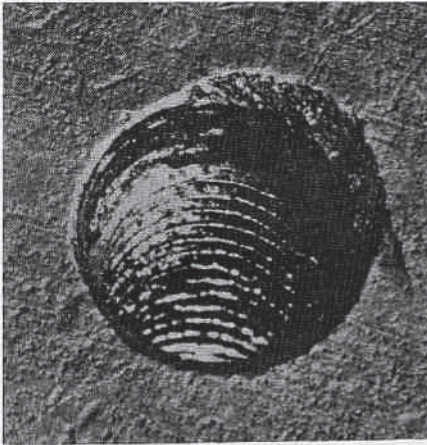

Fig. CS50 — Damaged threads in aluminum casting before repair. (Series provided by Heli-Coil Corp., Danbury, Connecticut).

DISASSEMBLY AND ASSEMBLY

Special techniques must be developed in chain saw repair because of the aluminum alloy or magnesium alloy construction. Soft threads in aluminum or magnesium castings are often damaged by carelessness in over-tightening fasteners or in attempting to loosen or remove seized fasteners. Manufacturer's recommended torque values for tightening screw fasteners should be followed closely.

A given amount of heat applied to aluminum or magnesium will cause it to expand a greater amount than will steel under similar conditions. Because of the different expansion characteristics, heat is usually recommended for easy installation of bearings, pins, etc., in aluminum or magnesium castings. Sometimes, heat can be used to free parts that are seized or where an interference fit is used. Heat, therefore, becomes a service tool and the application of heat one of the required service techniques. An open flame is not usually advised because it destroys the paint and other protective coatings and because a uniform and controlled temperature with open flame is difficult to obtain. Methods commonly used are heating in oil or water, with a heat lamp or in an oven or kiln. The use of water or oil gives a fairly accurate temperature control but is somewhat limited as to the size and type of part that can be handled. Thermal crayons are available which can be used to determine the temperature of a heated part. These crayons melt when the part reaches a specified temperature, and a number of crayons for different temperatures are available. Temperature indicating crayons are usually available at welding equipment supply houses.

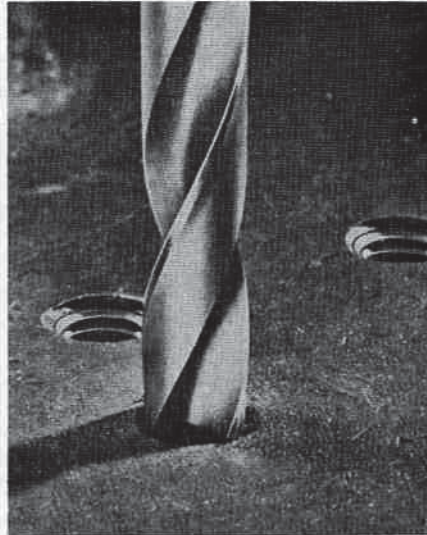

Fig. CS51 — Drill out the old threads or broken stud, using drill size recommended in instruction sheet which comes with kit. Drill all the way through an open hole or all the way to bottom of a blind hole, making sure hole is straight and that centerline is not moved in drilling process.

The crankcase and combustion chambers of a two-cycle engine must be sealed against pressure and vacuum. To assure a perfect seal, nicks, scratches and warpage are to be avoided. Slight imperfections can be removed by using a fine-grit sandpaper. Flat surfaces can be lapped by using a surface plate or a smooth piece of plate glass, and a sheet of 120-grit sandpaper or lapping compound. Use a figure-eight motion with minimum pressure, and remove only enough metal to eliminate the imperfection. Bearing clearances, if any, must not be lessened by removing metal from the joint. Remove crankshaft seals carefully using special tools where available. If seal bore in casting is scratched or slightly damaged, use sealing type cement when installing new seals.

Use only the specified gaskets when re-assembling, and use an approved gasket cement or sealing compound unless the contrary is stated. Seal all exposed threads and repaint or retouch with an approved paint.

Damaged threads in castings can be renewed by use of thread repair kits which are recommended by a number of chain saw and chain saw engine manufacturers. Use of thread repair kits is not difficult, but instructions must be carefully followed. Refer to Figs. CS50 to CS53 which illustrate the use of Heli-Coil thread repair kits that are manufactured by Insert Products Division, Heli-Coil Corporation, Danbury, Connecticut 06810.

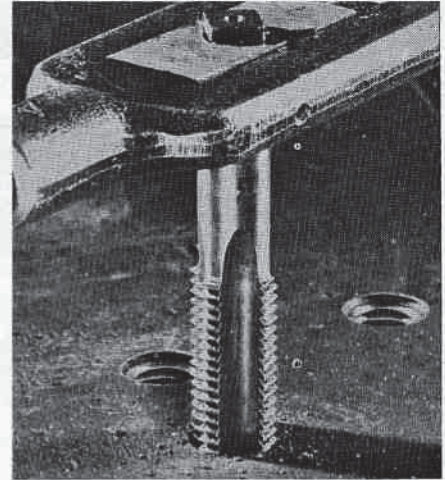

Fig. CS52 — Special drill taps are provided which are the correct size for OUTSIDE of the insert. A standard size tap cannot be substituted.

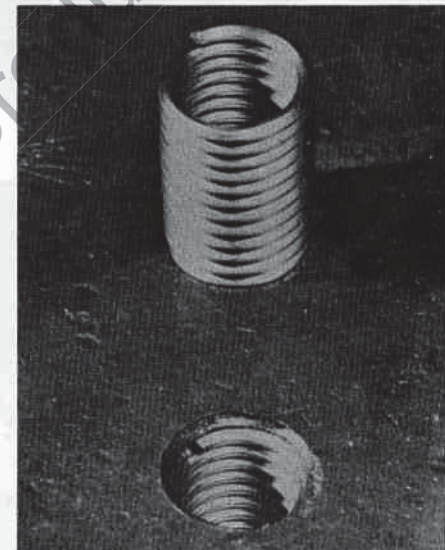

Fig. CS53 — Shown is the insert and a completed repair. Special tools are provided in kit for installation, together with the necessary instructions. Thread repair inserts are available for repairing damaged spark plug ports as well as for standard thread sizes.

SAW CHAIN MAINTENANCE

"Courtesy of Oregon Saw Chain Division, Omark Industries"

This section on saw chain maintenance has been prepared to give information that will enable the small engine mechanic to service the cutting chain as well as the engine of the chain saw. Information for trouble shooting saw chain problems is also given in this section.

SAW CHAIN TYPES

Some chains now in popular use can be classified into six types as:

Chipper Tooth Chain: 1/4", 3/8", .404", 7/16", 1/2", 5/8", 3/4" pitches; .050", .058", .063", .122" gauges.

80 Chain: .325", .404" pitches; .050", .058", .063" gauges.

S-70 and Speed-Guard: 3/8" pitch: .050", .058", .063" gauges.

Micro-Bit & Micro-Guard: .404", 7/16", 1/2" pitches; .050", .058", .063" gauges.

Super Chisel Chain: .404" pitch; .050", .058", .063" gauges.

Chisel Chain: 1/2", 9/16", 5/8" pitches: .058", .063" gauges.

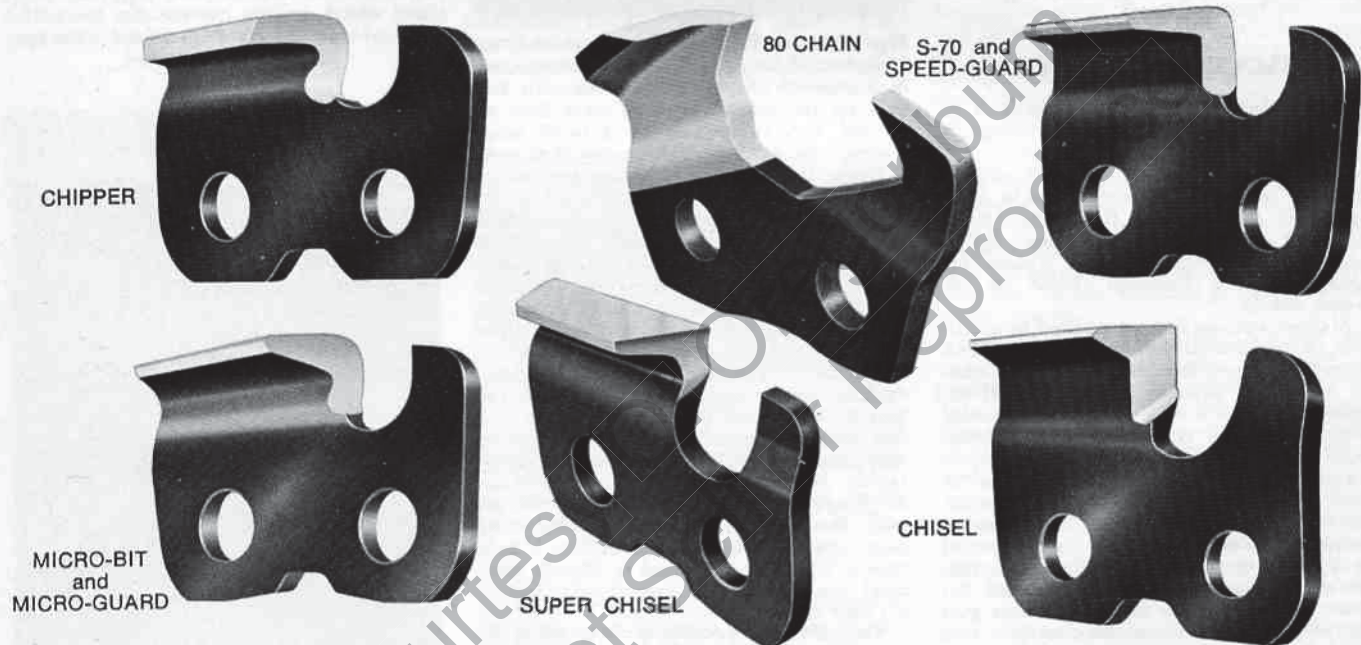

Fig. 1—Cutting links from each of the six types of saw chains.

SAW CHAIN NOMENCLATURE

To identify parts of a saw chain, refer to Fig. 2 for chipper type chains and to Fig. 3 for 80 series chains.

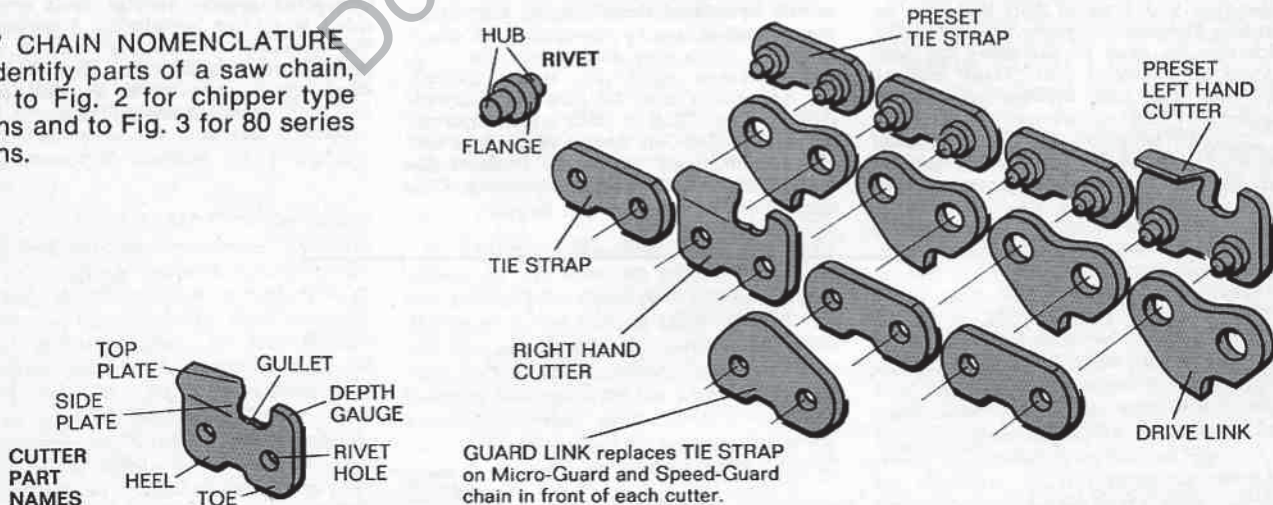

Fig. 2—Nomenclature of chipper type saw chains. Micro-bit, Super Chisel, S-70 and Chisel are similar except for cutter design.

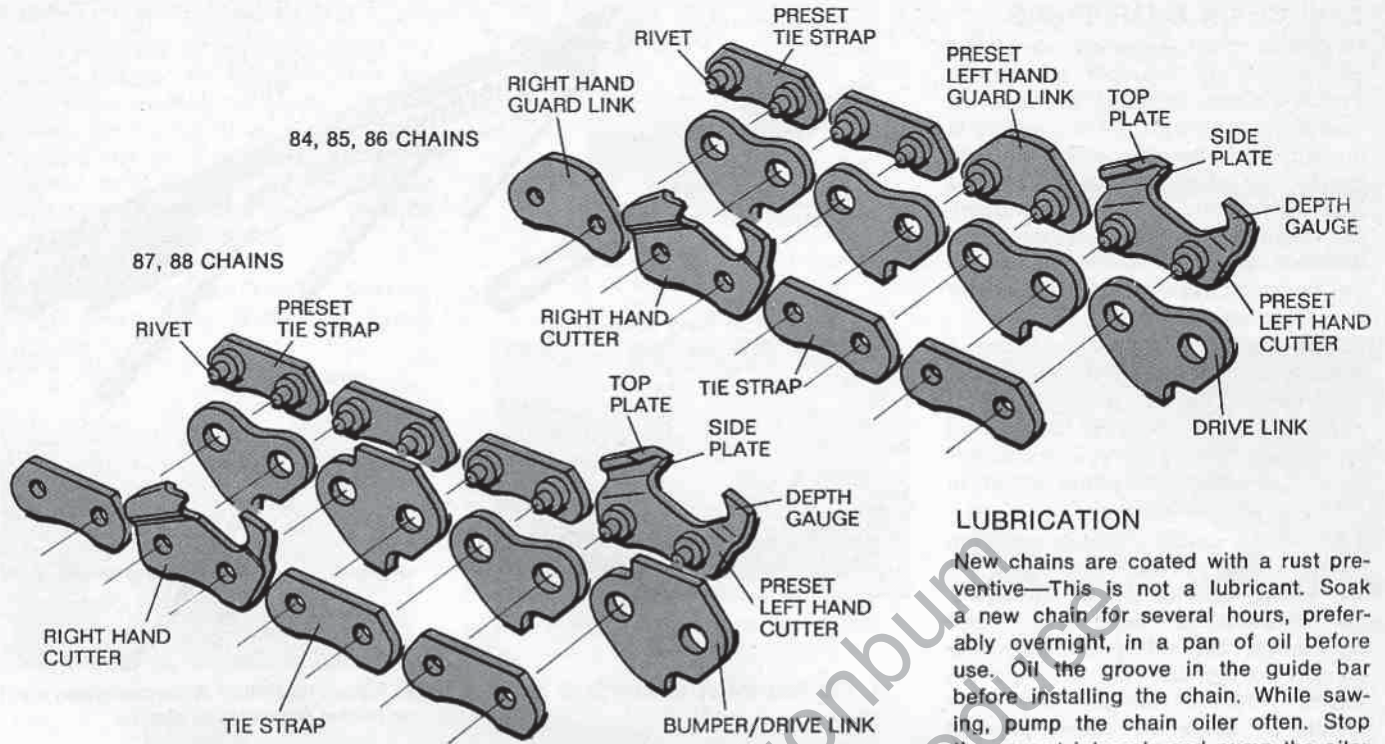

Fig. 3—Nomenclature of 80 series chains.

LUBRICATION

New chains are coated with a rust preventive—This is not a lubricant. Soak a new chain for several hours, preferably overnight, in a pan of oil before use. Oil the groove in the guide bar before installing the chain. While sawing, pump the chain oiler often. Stop the saw at intervals and pump the oiler as the chain is drawn around the bar. For maximum chain life, remove the chain after each day's use, sharpen, and clean and soak it overnight in a pan of oil.

CHAIN TENSIONING, BREAK-IN AND OILING

Loose chain tension is the major cause of all saw chain problems. It ruins chain, bar and sprocket. (Make sure ignition switch is off). Check chain tension often—here's how:

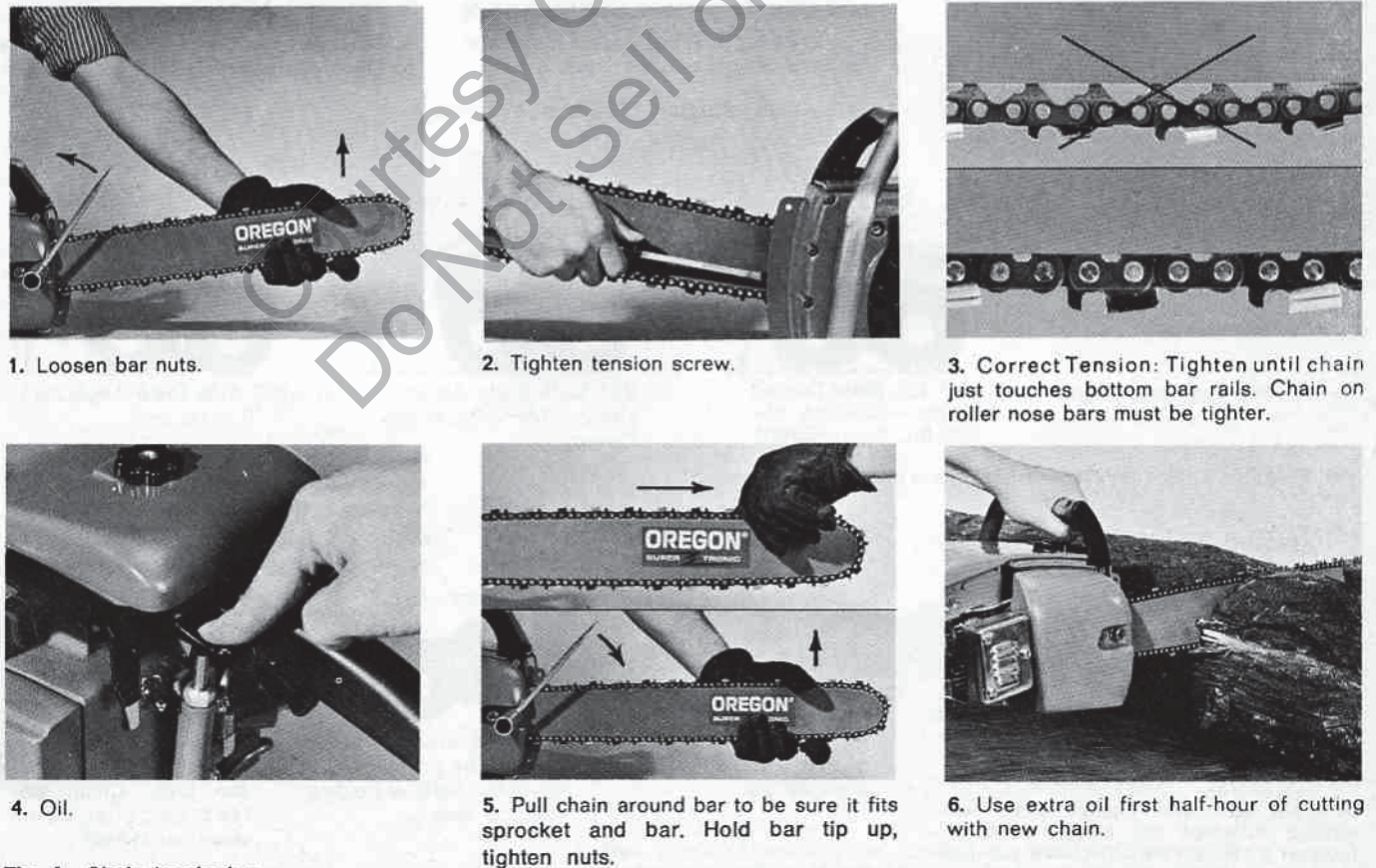

Fig. 4—Chain tensioning.

SAW CHAIN SHARPENING

Most saw chain operating complaints are caused by improper sharpening. One of the most important maintenance operations for trouble-free sawing is properly filing the saw chain. For best results, the chain should be removed from the saw and placed in a filing vise for sharpening (Fig. 5). If a vise is not available, the chain can be sharpened on the guide bar. Use of a file holder is also recommended (Fig. 5).

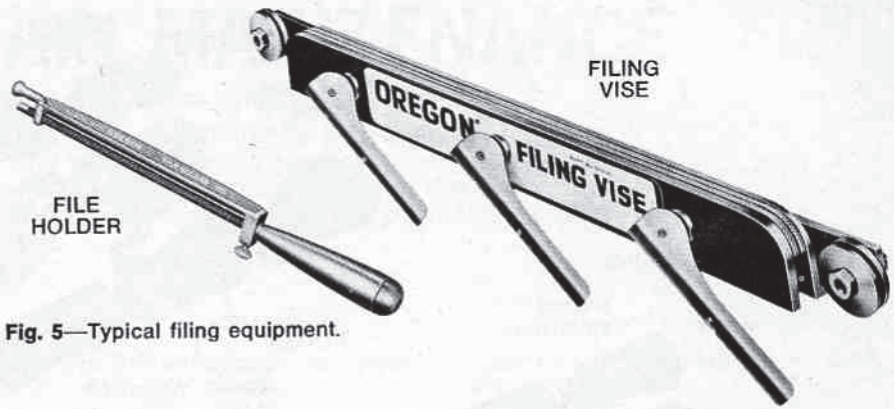

Fig. 5—Typical filing equipment.

Filing Standard (Chipper-Type) Chains

A full round file (not a rat tail) is used to sharpen the chipper-type chains. For good results, the procedures shown in Fig. 6 should be adopted.

For average sawing, maintain the filing angles shown in Fig. 7 by holding the file in the position shown in Fig. 6. Do not allow the file to drag on the backstroke, and rotate the file occasionally to increase file life. Approximately 1/10th of the file diameter should be above the cutting edge of the cutter. If the distance is less than this, the cutting edge will be too blunt; if distance is greater, a rapidly wearing feather edge will result. For convenience, file alternate (either all right hand or left hand) cutters; then reverse the chain in the vise or turn the saw around and file the remaining cutters. All cutters must be filed alike and the same amount to keep the cutting edges at the same height. Check this by laying a file or straightedge across the tops of the cutters. Continue filing high cutters in normal manner until all cutters are same height.



1. File from inside to outside of cutter.

2. Place File Holder on cutter—keep mark on holder parallel with chain.



3. Hold file level. Press against cutter and make 2 or 3 light strokes forward.



4. Sharpen all cutters on one side. Move to other side and file all cutters opposite.

Fig. 6—Filing standard chipper type chains.



Fig. 7—Filing angles for chipper type chain in average use.

Suggested File Sizes For Standard (Chipper-Type) Chain

| CHAIN PITCH | ROUND FILE SIZE |
|-------------|-----------------|
| 1/4" | 1/8" |
| .354" | 5mm |
| 3/8" | 3/16" |
| 3/8" (S-70) | 7/32" |
| .404" | 7/32" |
| 7/16", 1/2" | 1/4" |
| 9/16", 5/8" | 9/32" |
| 3/4" | 5/16" |

Different size and design chain will require different file sizes. If manufacturer's recommendations are not available, refer to the above chart.



Top plate angle not 35°—caused by holding file at wrong angle.

Hook in side plate—caused by pressing file down too hard, or holding file too low.

Backslope in side plate—caused by holding file too high. Chain won't feed properly; cutters wear fast at heel.

Fig. 8—Filing errors. If your cutters look like these, refile them.

DEPTH GAUGE SETTING

After filing the cutting edges, check the depth gauges, or riders as they are sometimes called, for correct distance below the cutting edges (Fig. 9). Depth gauges are generally checked with a jointer that is pre-set for the desired distance, as the one shown, or a jointer with an adjustable setting.

Average Depth Gauge Setting For Standard (Chipper Type) Chain

| CHAIN PITCH | DEPTH GAUGE SETTING |
|-------------|---------------------|
| 1/4" | .020" |
| .354" | .025" |
| 3/8" | .020" |
| 3/8" (S-70) | .025" |
| .404" | .030" |
| 7/16" | .030" |
| 1/2" | .040"-.030" |
| 9/16", 5/8" | .040" |
| 3/4" | .050"-.060" |

The normal top plate filing angle of 35° and the depth gauge distances for different pitch chain have been determined to be the most satisfactory for general sawing. However, the woodsman may, through trial and error, find the most suitable depth gauge distance for a particular condition. No specific figures can be given due to the variety of sawing conditions, but the following infor-



Check depth gauges every 3rd or 4th sharpening.

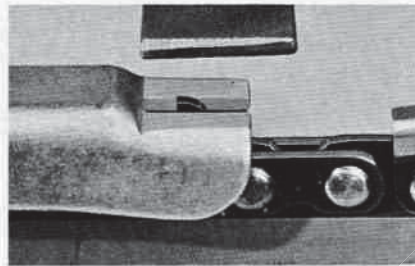

2. If depth gauge projects, file it level.

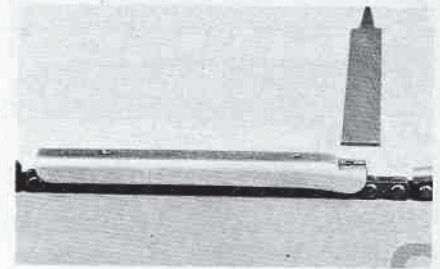

1. Place Gaugit on chain.

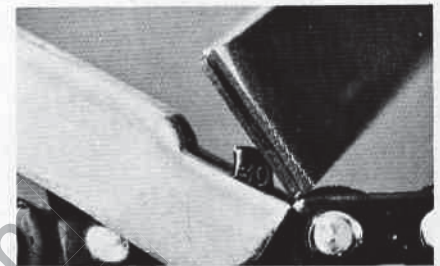

3. Round off front corner. Use tilted gaugit to protect top of cutter.

Fig. 9—Depth gauge setting

mation can be used as a guide.

A. On larger horsepower saws and saws with slow chain speeds, the depth gauge distance may be increased, which will allow the cutter to take a larger chip. The depth gauge distance should be decreased on small saws and direct drive saws.

B. When cutting continually in soft woods, the depth gauge distance can

be increased somewhat.

C. When cutting hard woods, frozen or resin timber, the depth gauge distance should be decreased.

When sharpening the cutting edges on the saw chain, the drive link tangs should also be sharpened to keep the guide groove clean, and any burrs on the sides of the drive link tangs should be removed. See Fig. 23.

FILING TYPE 80 CHAIN

This new type of chain features a revolutionary, unique cutter design which is hand sharpened from the top by means of a "top file guide" (see Fig. 10) and flat file. The "top file guide" provides accurate sharpening of cutter tops and lowering of depth gauges. Refer to Fig. 11 and Fig. 12 for filing procedures.

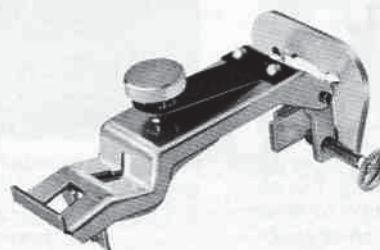
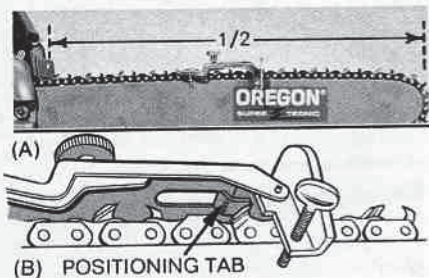

Fig. 10—80 chain top file guide. For hand sharpening 80 chain accurately and uniformly.

Fundamentals



1. (A) Place Top File Guide midway on bar, C-Clamp vertical and facing bar nose. (B) Positioning Tab rests on cutter top plate; Support Legs fit over middle of cutter to be filed. Tighten C-Clamp snug.



2. Hold down flat locking spring and turn Adjusting Knob until cutter projects slightly. Release spring.

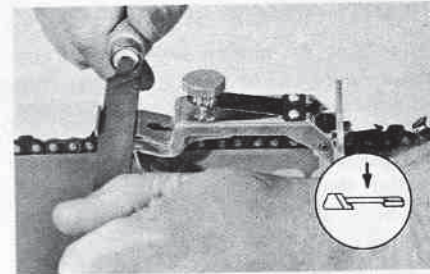

3. File cutter from inside toward outside of chain, until file slides freely. Hold file level at all times.

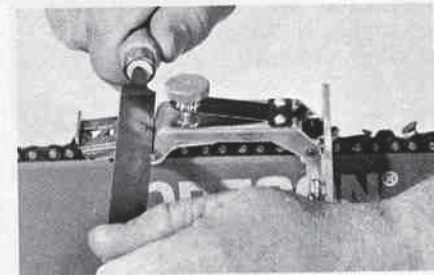

4. File depth gauge until file slides freely.



5. (A) Raise guide—not too high or it will hit C-Clamp and change setting; (B) Pull chain until next right hand cutter comes into position under Positioning Tab.

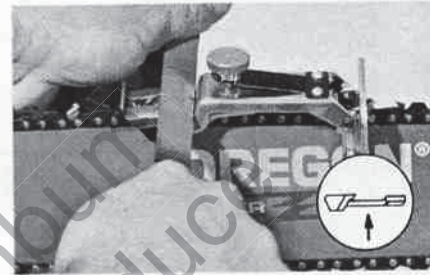

6. Press guide onto cutter and repeat steps 3 and 4. File all cutters on one side of chain, then move to other side of bar and file all cutters on opposite side—do not change setting.

Fig. 11—Filing 80 chain top plates. Make sure chain is tensioned tight before filing.

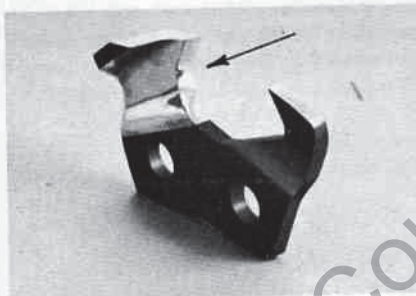

SIDE PLATE SHARPENING must be done by hand before every fifth time top plates are sharpened.

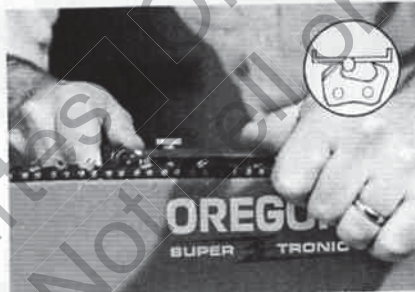

1. Place 5 mm. file holder (No. 12204) on cutter top plate and depth gauge. Hold it level. Care should be taken to avoid hitting top plates when filing side plates.

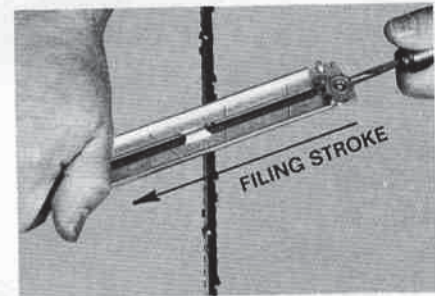

2. Hold file holder so that 24° guide mark is parallel to bar. File from inside toward outside of cutter. A few light strokes are enough.

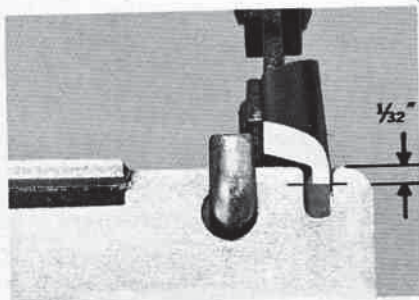

3. Measure side plate projection in notch of holder. It should be 1/32" long. File all cutters on one side of chain. Move to other side of bar and file all cutters on opposite side.

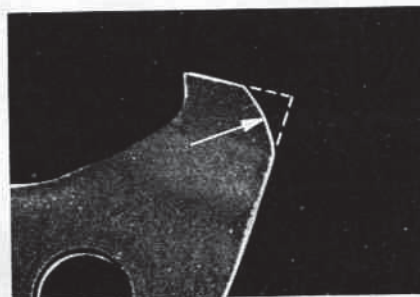

4. Maintain rounded front corner of depth gauge as shown here.

Fig. 12—Filing 80 chain side plates.

CHAIN SAWS

Fundamentals

FILING SUPER CHISEL CHAINS 50L, 51L, 52L

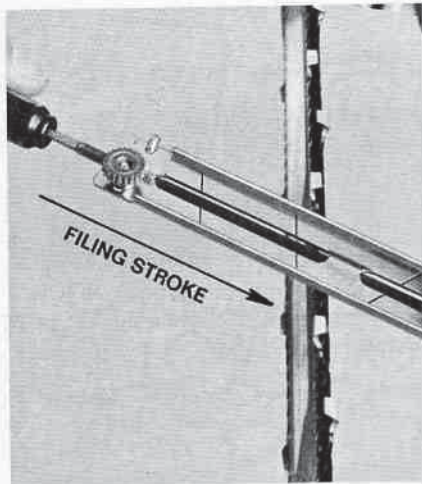

Use Oregon File Holder Part No. 13252 and round 7/32" file. Rest file holder on top of cutter top plate and depth gauge with guide marks in line with chain.



Hold file handle down 10° as you make a few light strokes forward, applying file pressure against cutting edge. File all cutters on side opposite yourself, then move to other side of chain to file all cutters on other side.

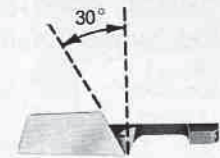

Top Plate Angle 30°.

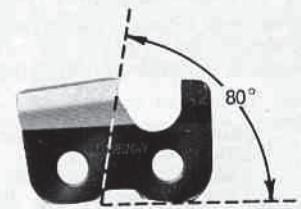

Side Plate Angle 80°.



Check Depth Gauges every third sharpening. See Fig. 9 for instructions on lowering depth gauges. Setting for Super Chisel is .025".

Fig. 13—Super chisel filing.

FILING CHISEL TOOTH CHAIN (Also Super Chisel Chains 50AL, 51AL, 52AL)

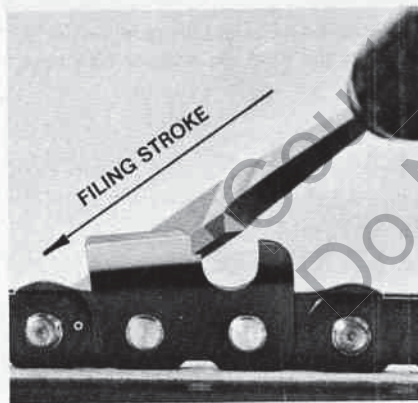

Hold file so its bevel corner fits into the front corner of the cutter. Filing stroke angles downward against the cutting edges, moving from front toward rear of cutter. File all cutters on one side of chain, then move to other side to file opposite cutters.

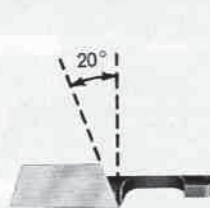
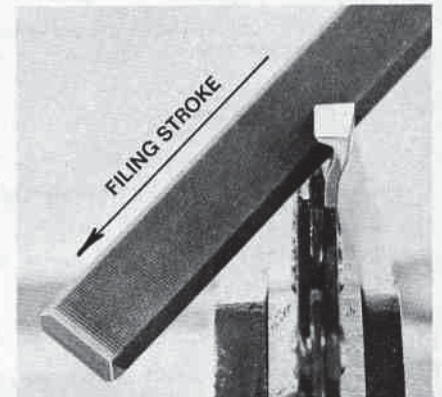
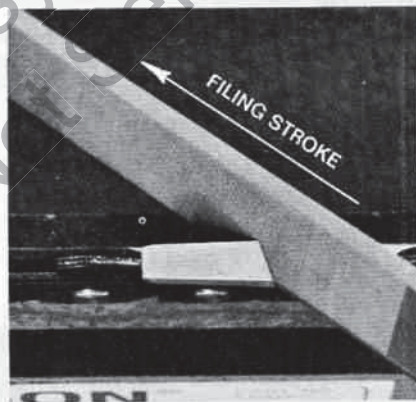

Top Plate Filing Angle 20°. Gradually increase angle as cutter is filed back.

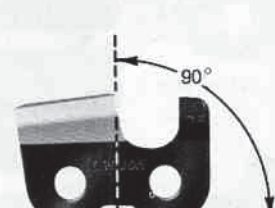

Side Plate Angle 90°.

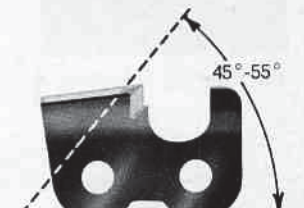

Top Plate Cutting Angle 45°-55°.

Fig. 14—Chisel tooth chain sharpening. By holding file in the single correct position, cutters should look like these.

FILING CHISEL TOOTH CHAIN, cont'd.
(Also Super Chisel Chains 50AL, 51AL, 52AL)

DEPTH GAUGE SETTING

Below is a list of correct depth gauge settings. Refer to Fig. 9 for correct procedure to use in lowering depth gauges.

| CHAIN | DEPTH GAUGE SETTING |
|----------------------------|---------------------|
| 50AL } 51AL } 52AL } | .025" |
| 9AL } 10AL } | .030" |
| 4AL } 5AL } | .040" |
| 16AL } 17AL } | .045" |



Check depth gauges every 3rd sharpening.

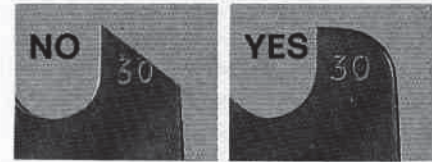

After lowering depth gauges, ROUND off front corner to maintain original shape.

Fig. 15—Depth gauge setting.

GULLETS

Use a round file, as shown in Fig. 16, to clean out gullets. Keeping the gullet open allows for better chip clearance and more efficient side plate cutting action.



Before every fifth sharpening, clean out gullets with round file. Hold file level and at 20° angle to cutter. Filing stroke is made in opposite direction from the sharpening stroke.

Fig. 16—Gullet Cleaning.

FILES TO USE

Refer to Fig. 17 for correct file to use for chisel tooth type chains.

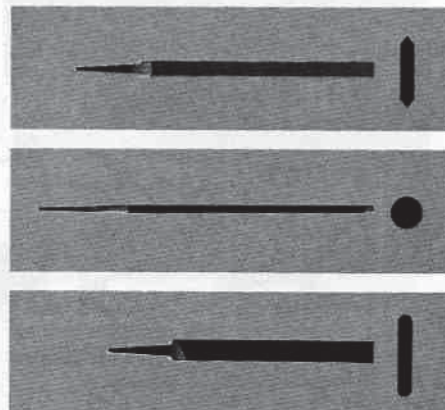

For sharpening: Use Oregon Chisel Chain File No. 13063 on all Oregon Chisel Chains. For 1/2" pitch and larger Oregon Chisel Chains, Oberg No. 149, Nicholson No. 5650 or Heller No. 3849 may be substituted.

For cleaning gullets: Oregon 7/32" round file No. 55400A.

For setting depth gauges: Safety edge flat file Oregon No. 12211A.

Fig. 17—Use correct file for each filing job.

CHAIN SAWS

CHAIN REPAIR

Removing Broken Drive Links

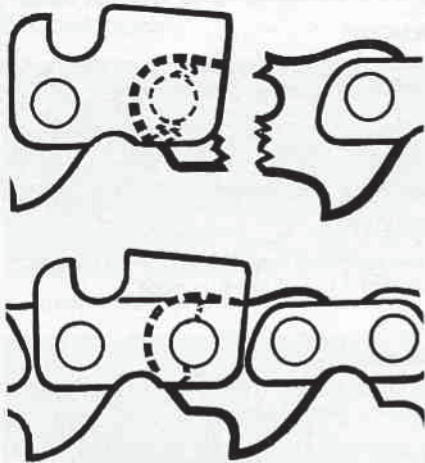

Fig. 18—Drive links usually break at the rivet hole. Hold broken link together on chain breaker while driving out rivets.

Installing New Parts

Refer to Fig. 19 for correct procedure.



1. Fit chain into smallest slot of Chain Breaker so cutter is on top. Punch out rivets of damaged part.

2. File off bottom of new part to match worn parts. File new cutter back to match worn cutters.



3. Put preset part on flat surface.

4. Install chain on new part.

5. Dimple on tie strap faces out. Form rivet head with hammer.

Fig. 19—Installing new parts.

TROUBLE SHOOTING

CUTTER PROBLEMS

What to do if chain cuts slow or won't hold its edge:

1. Remove chain from bar.
2. Clean chain with solvent to remove pitch and resin.
3. Compare each cutter to those pictured in Fig. 20.
 - a. If cutters are damaged by abrasion (Nos. 1, 2, 3) file or grind out the damaged portion.
 - b. If chain is incorrectly filed (Nos. 4 through 11) sharpen cutters following instructions in this manual.
 - c. If none of these defects are present, check carburetor for correct adjustment—see your saw manual.

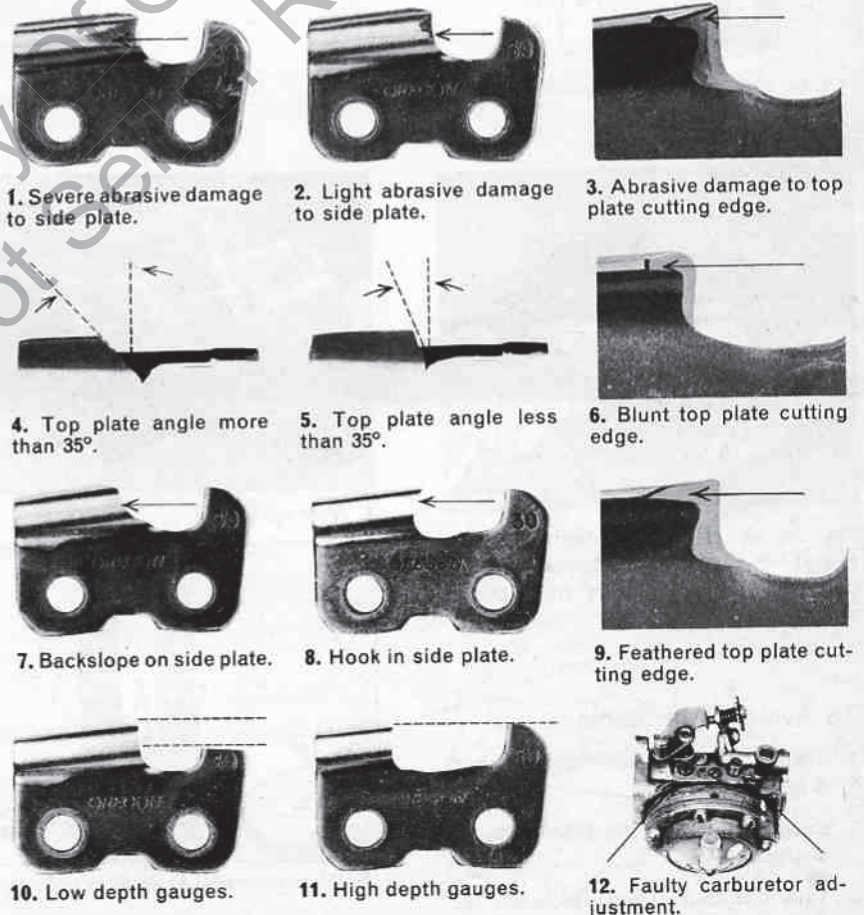

Fig. 20—Cutter problems.

DRIVE LINK PROBLEMS

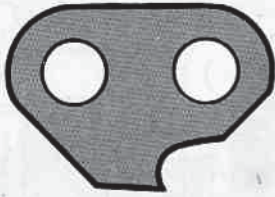

Fig. 21—New drive link. Compare the appearance of the drive links on your chain to this one. If they are damaged, find the cause in Fig. 23.

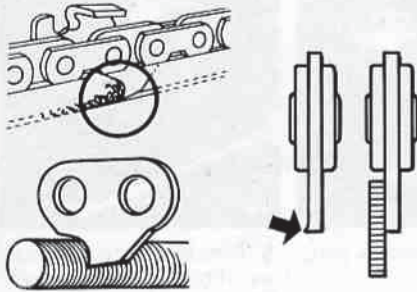

Fig. 22—Keep drive link tangs sharp. Use a round file for the fronts, and a flat file to deburr sides.

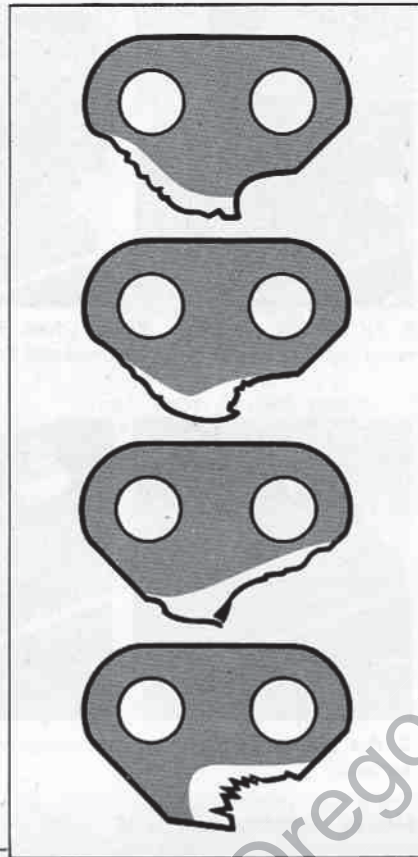

Fig. 23—Drive link damage.

CAUSE:
Loose chain climbs up on sprocket teeth.

REMEDY:
Tension chain properly. See Fig. 4.
Replace all damaged drive links.

CAUSE:
Bottoming in sprocket.

REMEDY:
New sprocket may prolong life of chain, but useful life of chain is gone.

CAUSE:
Striking side of bar entry or rim type sprocket is misaligned.

REMEDY:
Refunnel entry or align rim type sprocket with bar groove.

CAUSE:
Loose chain jumping bar.

REMEDY:
Adjust chain tension. See tensioning instructions, Fig. 4.

TIGHT JOINTS

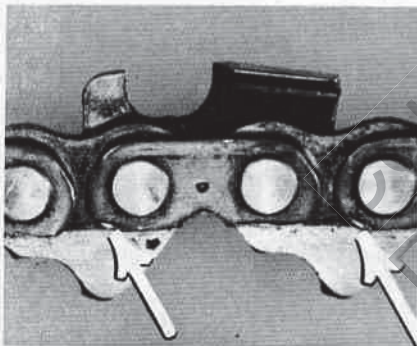
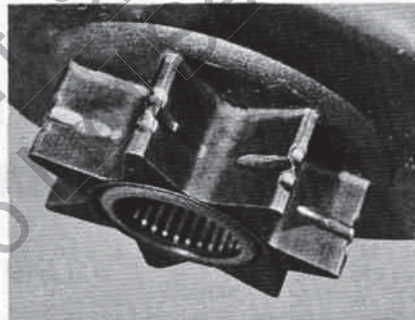
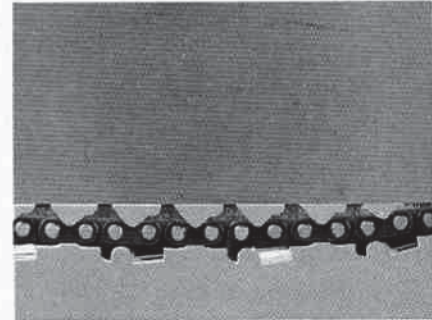

Fig. 24—A chain with tight joints is ruined—it cannot be repaired. Bottoms of tie straps and cutters have burred and peened edges.



1. Worn sprocket.



2. Loose chain tension.

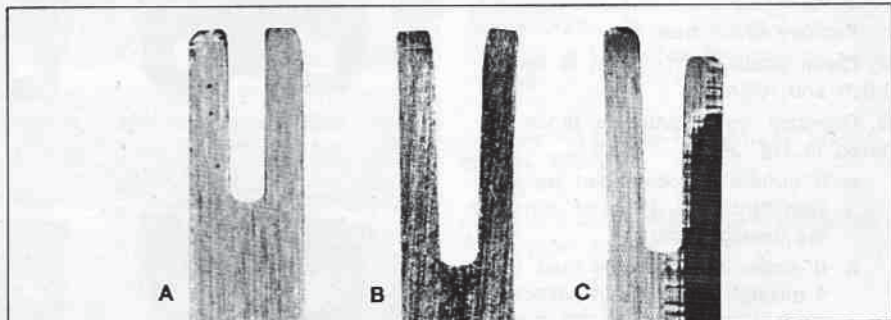

3. Worn bar rails. A) Shallow groove. B) Spread rails. C) Uneven rails.

To Avoid Tight Joints:

1. Always install a new sprocket with a new chain.
2. Keep chain correctly tensioned and sharpened.
3. Take bar to qualified bar repair service for repair or replacement.

Fig. 25—Causes of tight joints.

CROOKED CUTTING

When a chain cuts crooked or runs to one side it is due to: (1) Incorrect cutter filing or (2) Worn bar. Here's what to do:

1. Check cutters

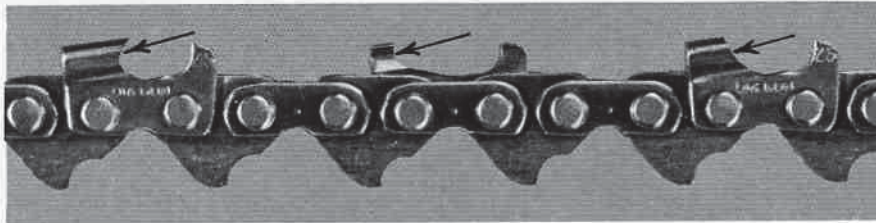

a. Incorrectly filed chain cuts crooked.

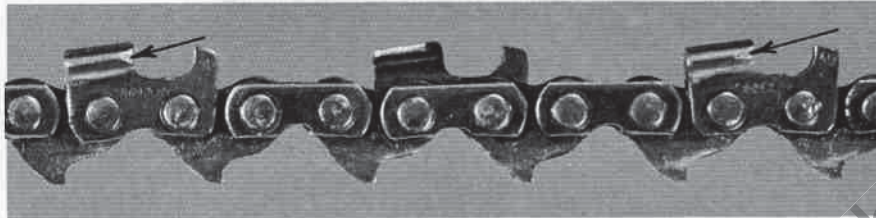

b. Chain damaged by abrasion cuts crooked.

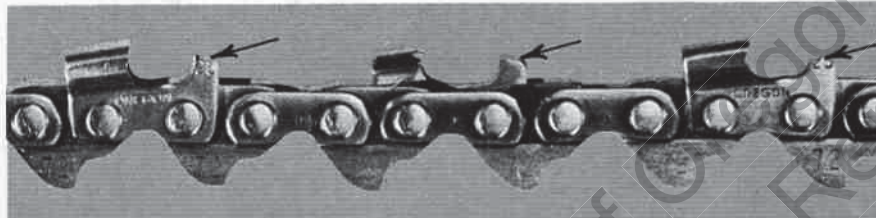

c. Chain with incorrectly set depth gauges cuts crooked.

Fig. 26—Cutter conditions causing crooked cutting.

2. Check bar for worn rails.

Place a straightedge against side of bar and one cutter. If there is clearance between bar and straightedge, the bar rails are good.

If chain leans and there is no clearance between bar and straightedge, the bar rails are worn. Bar needs replacement.

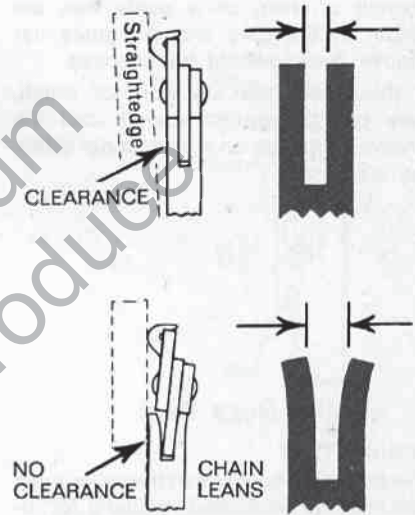

Fig. 27—Checking for worn bar rails.

HOW TO CARE FOR SOLID NOSE AND ROLLER NOSE BARS

Solid Nose Bars

Guide rails are sometimes split from the bar being pinched while the saw is hung up in a cut. Splits of two inches long or less can be repaired by using ordinary welding methods on bars with non-hardened rails. Repairing splits on bars with hardened rails requires special equipment for re-hardening the rails.

Small kinks or bends in guide bars can be removed by laying the bar on a large true anvil or other similar work surface and using light hammer blows to bring the bar back into shape. Technique is very similar to straightening other flat metal pieces.

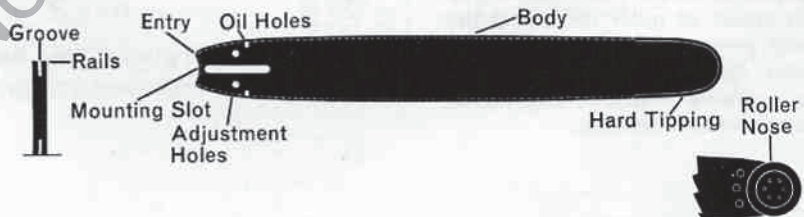

Fig. 28—Bar nomenclature.

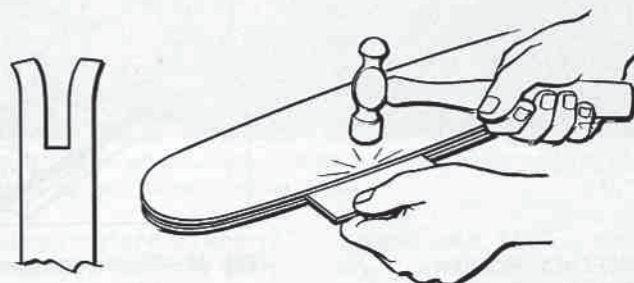

Fig. 29—Closing spread bar rails. Use steel shim .004" thicker than drive link tangs.

Use a file to funnel the entrance to the guide rail groove of the bar as shown in the "right" view in Fig. 30. If the guide rails are as in the "wrong" view in this illustration, damage to the chain can occur as the chain enters the groove.

Check the fit of the chain to the guide bar as shown in Fig. 31. If the tangs of the drive links touch the bottom of the guide rail groove, poor cutting and damage to the chain will result. The side links of the chain should ride on the rails and the tangs should clear the bottom of the guide groove. When replacing a chain or a guide bar, the length of the tang and the guide bar groove depth should be checked.

If the guide rails are worn or rough, they can be ground smooth and the groove deepened on a special bar grinding machine.

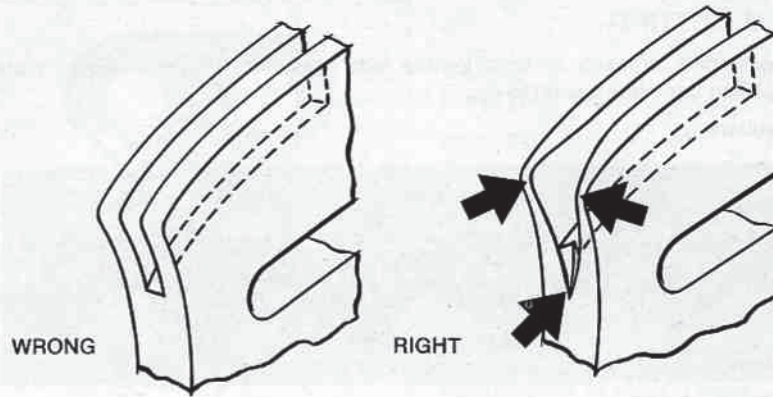

Fig. 30—Cut funnel shaped opening to guide groove with file.

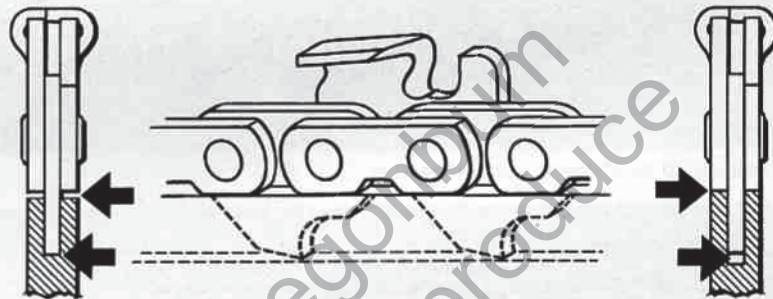

Fig. 31—Guide groove too shallow in cross section view at left. Tang must clear bottom of groove as in cross section view at right.

Roller Nose Bars

LUBRICATION

The precision bearings in the roller nose bar must be lubricated regularly for efficient operation and long life. When: Grease the roller nose bearing every time you gas the saw. Always grease the bearing at the end of the days work. How: Clean hole. Use Oregon lube gun or regular hand-grease gun with needle nozzle.

Steady the bar with one hand and hold grease gun in other. Insert nozzle into hole in center of roller and pump the gun until grease flows from the rim of the roller. See Fig. 32. Use any good type gun grease available. Use lighter grease for winter operation.

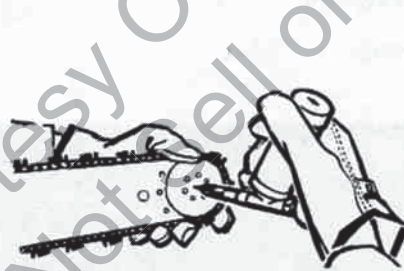

Fig. 32—Lubricating roller nose bar.



Fig. 33—Removing burrs from roller side plates.

SIDE PLATE CARE

Refer to Fig. 33. Remove burrs that form on the side plates of the roller with a flat file. Pump bearing full of grease before filing. File away from the slot so filings don't get into bearing. Wipe filings from inside and outside the roller before remounting chain.

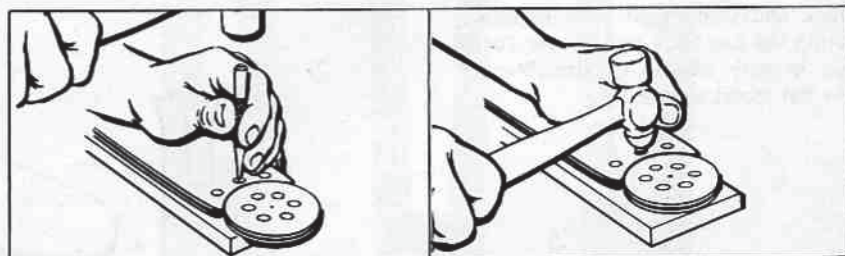

Fig. 34—Replacing roller.

HOW TO REPLACE ROLLER

Refer to Fig. 34 for correct procedure.

1. Lay bar on solid surface with a hole under rivet.
2. Drill or punch out rivets. Be careful not to crack mounting holes.
3. Insert new roller into bar. Insert new rivets and peen them gently.

SPROCKET PROBLEMS

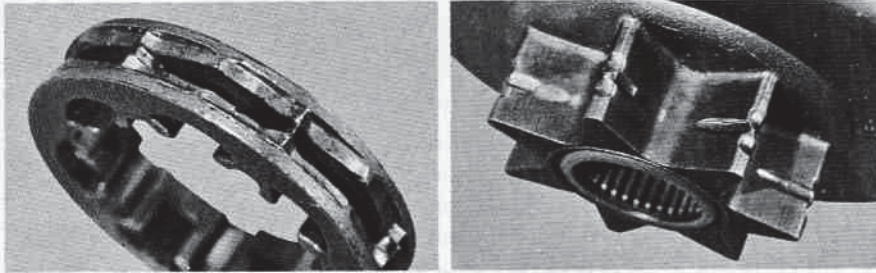

Fig. 35—The only cure for a worn sprocket is a new one. Worn sprockets can ruin a new chain in a short time. A chain costs five times as much as a sprocket so there is no economy in using a worn sprocket with a new chain. These worn sprockets will damage and weaken a saw chain beyond repair.

Avoid Sprocket Problems

1. Always install a new sprocket with a new chain.
2. Keep chain properly tensioned. See tensioning instructions Fig. 4.
3. Grease bearing whenever sprocket is removed from saw.
4. Keep bar rails in good condition.
5. Keep chain cutters correctly sharpened.
6. Use plenty of oil when cutting.

SELF-ALIGNING SPROCKETS

Self-aligning rim sprockets give smoother chain operation, as the rim slides on the drum so the chain lines up with the bar groove. There's less wear and chain damage as the chain is supported on the circular rim. Several pitch sizes of rims fit any of the splined drums. The drums are available with either needle or "Oilite" bearings, depending on the saw model they fit.

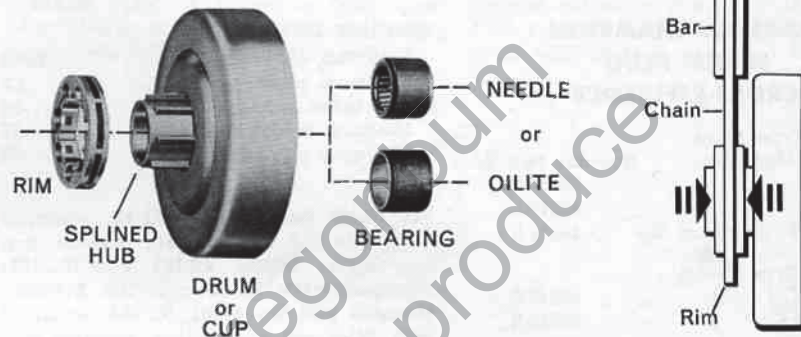

Fig. 36—Self-aligning rim sprocket.

How To Install

Self-aligning sprockets will fit both in-board and outboard mounted clutch assemblies. Refer to Fig. 37 for proper installation procedure.

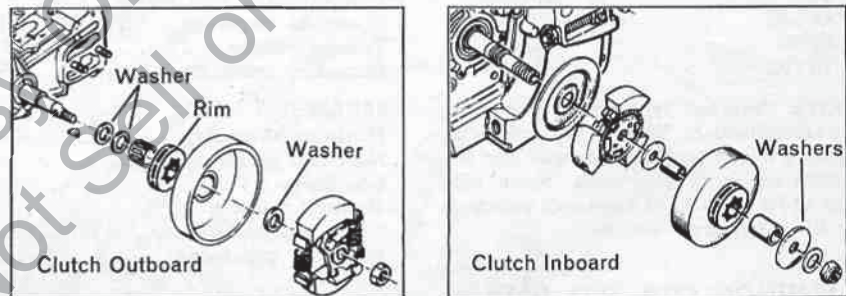

Fig. 37—Installation sequence of parts relating to sprocket and clutch.

COLD WEATHER CUTTING PROBLEMS

To extend chain life when cutting in cold weather, do these things:

1. Oil—Mix chain oil half and half with kerosene. Use twice as much oil while cutting with this mixture. Be sure oiler is working.
2. Tension—Keep chain tensioned—check often. See Fig. 4.



Fig. 38—Cutting frozen wood causes cutters to wear, crack and break at the back rivet hole unless proper precautions are taken.

3. Cutters—Keep cutters properly sharpened. Touch up at least every hour. Never force a dull chain to cut.
4. Bar—Clean out bar groove and keep

- oil hole open. Turn bar over to equalize wear on rails.
5. Sprocket—Always install new sprocket with new chain.

HOMELITE

A **textron** DIVISION
 PORT CHESTER, N.Y. U.S.A.

IGNITION SYSTEM SPECIFICATIONS

HOMELITE-CHAMPION SPARK PLUG CROSS-REFERENCE

"Shorty" Type Plugs:

| Champion Model No. | Homelite Part No. |
|------------------------|-------------------|
| TJ-6J | 59654-S |
| TJ-8J | 58917-S |
| UTJ-11P (Platinum tip) | 59558-S |

"Bantam" Type Plugs:

| | |
|------|---------|
| CJ-6 | 63547-S |
| CJ-8 | 63710-S |

Tapered Seat Type Plugs:

| | |
|-------|---------|
| DJ-6J | 65130-S |
|-------|---------|

Regular 2-Cycle Type Plugs:

| | |
|--------|---------|
| J-6J | 40190-S |
| UCJ-7G | 65444 |
| UJ-7G | 65545-S |
| UJ-11G | 65544-S |

NOTE: "Bantam" type spark plugs may be used instead of "Shorty" type plugs by installing a new terminal (Homelite part No. A-33055) on spark plug wire. Spark plug types UJ-7G and UJ-11G have gold paladium tips for heavy duty service.

IGNITION COIL TEST DATA

Test data for use with Merc-O-Tronic and Graham coil testers to check Homelite chain saw ignition coils is given by chain saw model number, coil manufacturer's coil model number and Homelite part number. Note: Use test procedure specified by coil tester manufacturer.

For Chain Saw Models: 5-30 and 5-30NA; equipped with Wico coil No. X7536, Homelite part No. 72397.

MERC-O-TRONIC TEST DATA:

| | |
|----------------------|-------|
| Operating amperage | 1.90 |
| Secondary resistance | 38-58 |

GRAHAM TEST DATA:

| | |
|-------------------|-------|
| Maximum secondary | 8,000 |
| Maximum primary | 1.2 |
| Coil index | .60 |
| Minimum coil test | .17 |
| Maximum gap index | .70 |

For Chain Saw Models: XL-12; equipped with Wico coil No. X14171D, Homelite part No. 58874. **XL-101, XL-102 and XL-103;** equipped with Wico coil No. X16825C. Homelite part No. 64091. **XL-104;** equipped with Wico coil No. X17108, Homelite part No. 64435. **XL-700 and XL-800;** equipped with Wico coil No. X16343C, Homelite part No. 63625.

MERC-O-TRONIC TEST DATA:

| | |
|----------------------|---------|
| Operating amperage | 1.30 |
| Primary resistance | 0.6-0.7 |
| Secondary continuity | 50-60 |

GRAHAM TEST DATA:

| | |
|--------------------|--------|
| Maximum secondary | 10,000 |
| Maximum primary | 1.7 |
| Coil index | .65 |
| Minimum coil test: | |
| All other models | .27 |
| Maximum gap index | .65 |

For Chain Saw Models: 775D, -G, 995D, -G, ZIP, all WIZ, Super 77, all "C" Series and all "XP" Series; use Phelon coil No. FG-3032B, Homelite part No. 55986B.

MERC-O-TRONIC TEST DATA:

| | |
|----------------------|-----|
| Operating amperage | 1.8 |
| Secondary continuity | 70 |

GRAHAM TEST DATA:

| | |
|-------------------|--------|
| Maximum secondary | 11,000 |
| Maximum primary | 2.5 |
| Coil index | .75 |
| Minimum coil test | .26 |
| Maximum gap index | .70 |

For Chain Saw Models: XL-850, XL-875 and XL-904; equipped with solid state magneto using Wico coil No. X-16669 or X-16669B (Homelite part No. 63998 or 63998-A) ignition coil:

MERC-O-TRONIC TEST DATA:

| | |
|----------------------|---------|
| Operating amperage | 1.3 |
| Primary resistance | 0.6-0.7 |
| Secondary continuity | 50-60 |

GRAHAM TEST DATA:

| | |
|-------------------|--------|
| Maximum secondary | 10,000 |
| Maximum primary | 1.7 |
| Coil index | .65 |
| Minimum coil test | .20 |
| Maximum gap index | .65 |

For Chain Saw Models: XL-104, XL-904 and others with service installed capacitor discharge (CD) Phelon magneto using Homelite part No. 67164 or 67277 transformer coil:

MERC-O-TRONIC TEST

DATA: See Note

GRAHAM TEST DATA: See Note

TEST WITH OHMMETER:

| | |
|----------------------|----------------|
| Primary resistance | 0.2-0.25 ohms |
| Secondary resistance | 2400-2900 ohms |

Note: For current test procedures, refer to page 58 for models XL-850, XL-875 and XL-904, or to page 86 for model XL-104.

For Chain Saw Models: EZ and EZ-Auto-matic; use Homelite part No. A-65204 ignition coil and core assembly.

MERC-O-TRONIC TEST

DATA: Not Available

GRAHAM TEST DATA:

| | |
|-------------------|--------|
| Maximum secondary | 10,000 |
| Maximum primary | 1.0* |
| Coil index | .75 |
| Minimum coil test | .18 |
| Maximum gap index | .75 |

* Approximate

HOMELITE
 A **Textron** DIVISION
 PORT CHESTER, N.Y. U.S.A.

MODEL COVERAGE

| CHAIN SAW MODEL | DESIGN FEATURES |
|-------------------------|-----------------|
| EZ | A,C,D,E,F |
| EZ Automatic | B,C,D,E,G |
| XL-Mini | A,C,D,E,F |
| XL-Mini Automatic | B,C,D,E,G |

DESIGN FEATURES CODE

- A—Displacement, 2.1 cu. in.; bore, 1.4375 in.; stroke, 1.3 in.
- B—Displacement, 2.3 cu. in.; bore, 1.5 in.; stroke, 1.3 in.
- C—Pyramid reed type intake valve, 4 reeds.
- D—Conventional flywheel type magneto.
- E—Direct drive.
- F—Manual chain oiler only.
- G—Automatic and manual chain oiler systems.

MAINTENANCE

SPARK PLUG. A Champion DJ-6J spark plug with tapered seat is used; no gasket is required. Adjust electrode gap to 0.025.

CARBURETOR. Refer to Fig. HL1 for exploded view of Walbro series HDC carburetor. A model HDC-1 carburetor is used on model EZ Automatic and a model HDC-2 is used on model EZ. Carburetors are alike except for size of fuel limiting jet (7). For description of carburetor operating principles and carburetor overhaul procedure, refer to **HOMELITE PICTORIAL SERVICE GUIDE** for model EZ and EZ Automatic Chain Saws.

For initial carburetor adjustment, back idle speed adjusting screw (15) out until throttle valve will completely close, then turn screw back in until it contacts idle stop (13) plus 1/2 turn additional. Turn both fuel adjusting needle (16) in until lightly seated, then back main fuel needle (located to left and marked "HI" on grommet when viewing adjustment needle side of throttle handle) out about one turn and back idle ("LO") needle out about 3/4-turn. Start engine, readjust idle speed and fuel needles

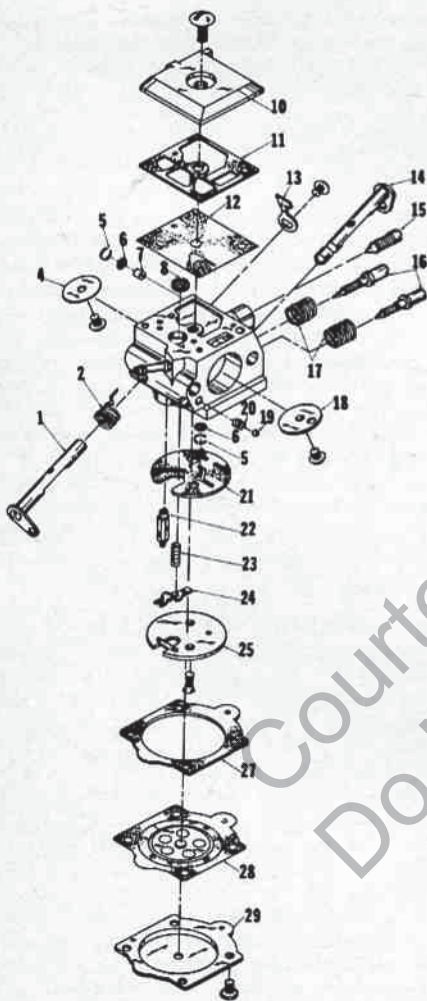

Fig. HL1—Exploded view of Walbro series HDC carburetor. Model HDC-1 carburetor is used on model EZ Automatic; HDC-2 is used on model EZ.

- | | |
|-----------------------|--------------------------|
| 1. Throttle shaft | 16. Idle fuel needle |
| 2. Return spring | 17. Friction springs |
| 4. Throttle valve | 18. Choke valve |
| 5. Snap rings | 19. Choke friction ball |
| 6. Check valve screen | 20. Friction spring |
| 7. Limiting jet | 21. Gasket |
| 8. Fuel inlet screen | 22. Inlet needle valve |
| 10. Fuel pump cover | 23. Metering lever |
| 11. Gasket | 25. Circuit plate spring |
| 12. Pump diaphragm | 27. Gasket |
| 13. Throttle stop | 28. Metering diaphragm |
| 14. Choke shaft | |
| 15. Idle speed screw | |

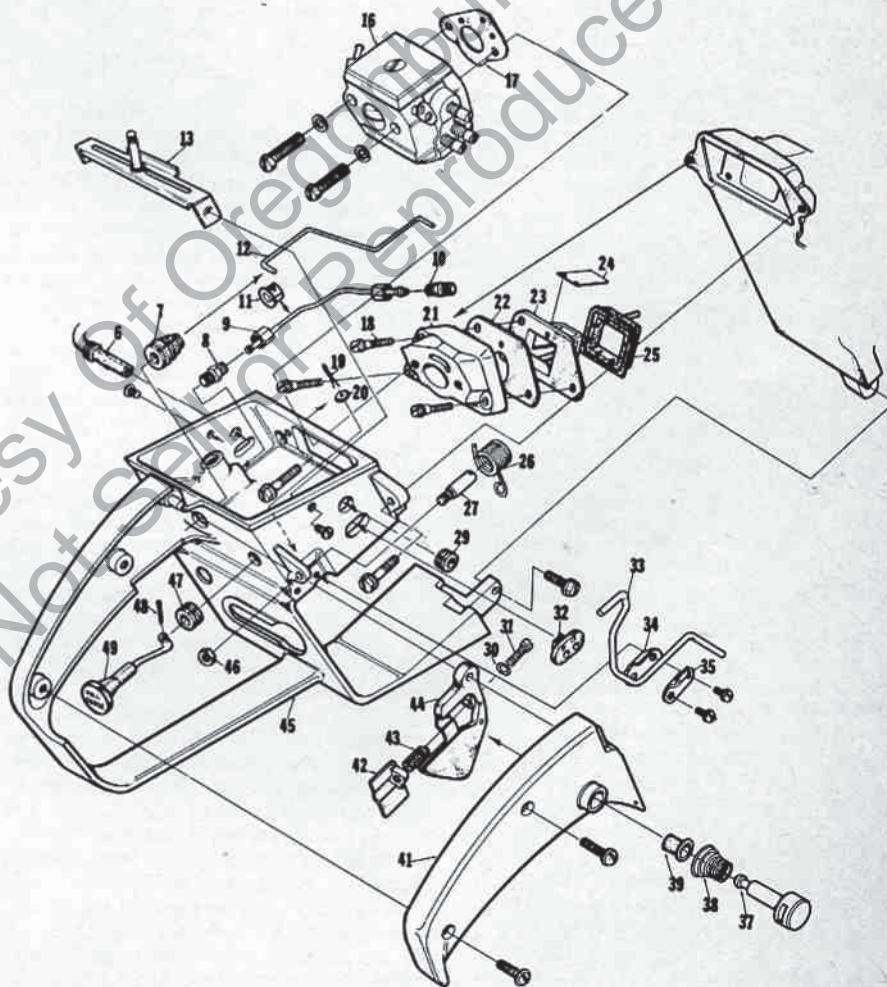

Fig. HL2—Throttle handle exploded view showing carburetor and reed valve installation, throttle trigger, choke rod and related parts. Latest type reed valve installation is shown. Refer to Fig. HL3 & HL4 for earlier production

- | | | | |
|------------------------|-----------------------|-------------------------------------|----------------------|
| 6. Fuel line | 17. Gasket | 27. Spring post | 38. Spring |
| 7. Rubber boot | 19. Cotter pin | 29. Grommet | 39. Bushing |
| 8. Check valve | 20. Felt washer | 30. "O" ring | 41. Handle cover |
| 9. Oil line | 21. Reed valve spacer | 31. Starting speed adjustment screw | 42. Throttle stop |
| 10. Connector | 22. Gasket | 32. Grommet | 43. Spring |
| 11. Grommet | 23. Reed valve seat | 33. Release lever | 44. Throttle trigger |
| 12. Throttle rod | 24. Valve reeds | 34. Lever plate | 45. Throttle handle |
| 13. Air filter bracket | 25. Reed retainer | 35. Lever clamp | 47. Grommet |
| 16. Carburetor | 26. Spring | 37. Throttle latch pin | 48. Cotter pin |
| | | | 49. Choke rod |

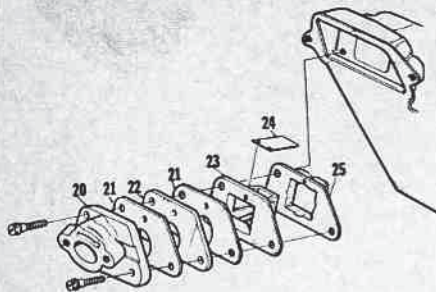

Fig. HL3—View showing earliest production reed valve and spacer installation.

- 20. Reed spacer
- 21. Gaskets
- 22. Spacer
- 23. Reed seat
- 24. Valve reeds
- 25. Reed retainer

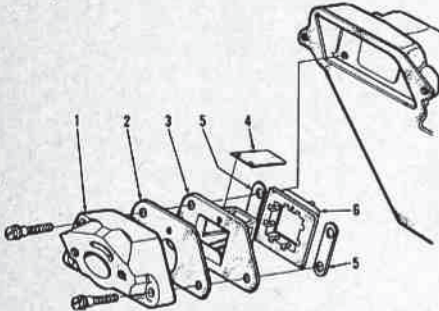

Fig. HL4—View showing reed valve and spacer installation used later in production than parts shown in Fig. HL3, but prior to installation shown in Fig. HL2.

- 1. Reed spacer
- 2. Gasket
- 3. Reed seat
- 4. Valve reeds
- 5. Spacers
- 6. Reed retainer

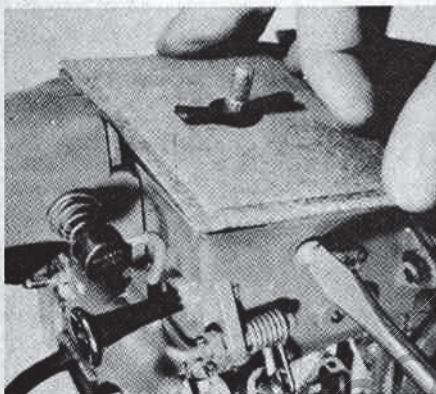

Fig. HL5—Before tightening screws retaining air filter bracket (13—Fig. HL2) in throttle handle, place air filter element on bracket stud and align filter with edges of air box.

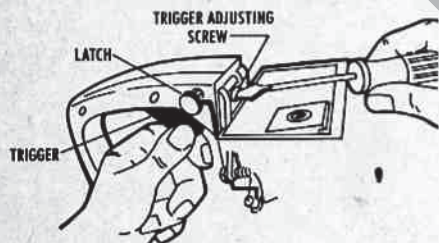

Fig. HL5A—Adjusting starting speed for models EZ and XL-Mini. Refer to text for procedure.

so that engine idles at just below clutch engagement speed. With engine running at full throttle under load, readjust main fuel needle so that engine will run at highest obtainable speed without excessive smoke. To adjust starting speed (speed at which engine will run with throttle latch engaged),

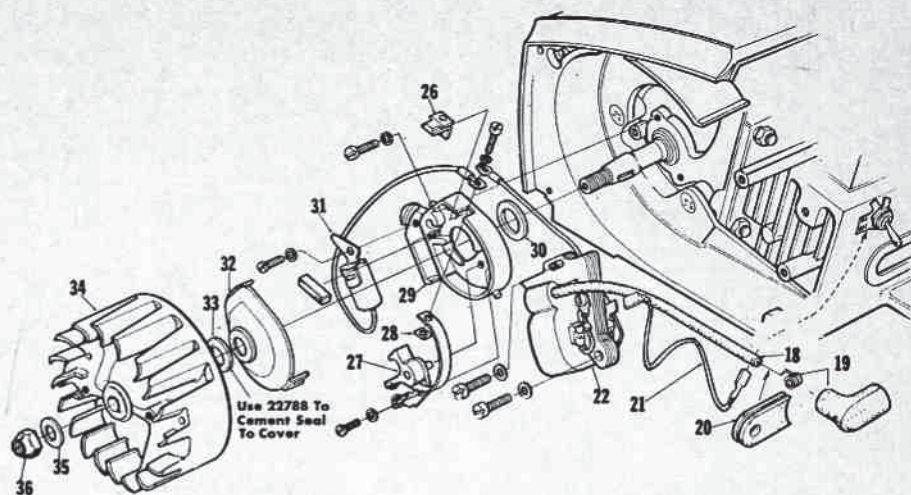

Fig. HL6—Exploded view of conventional breaker point flywheel magneto used on both model EZ and EZ Automatic. Felt seal (30) is retained by breaker box; felt seal (33) is cemented to breaker box cover. Projection on condenser (31) mounting bracket holds condenser lead in position.

- 18. High tension lead
- 19. Spark plug terminal
- 20. Grommet
- 21. Ground lead
- 22. Ignition coil & core
- 26. Insulator
- 27. Breaker points
- 28. Square nut
- 29. Breaker box
- 30. Felt seal
- 31. Condenser
- 32. Breaker box cover
- 33. Felt seal
- 34. Rotor (flywheel)
- 35. Flat washer
- 36. Crankshaft nut

stop engine and remove chain, guide bar, air filter cover and air filter. Open trigger adjusting screw 1/8-turn clockwise. With trigger latched, start engine and run at half throttle (not at high speed) for 30-50 seconds to warm it up. Release throttle trigger, then latch it while engine is running. If engine stops, restart it. With throttle trigger latched, gently hold trigger down and slowly back trigger adjusting screw out counter-clockwise until engine falters, then turn screw back in 1/16-turn clockwise. Squeeze and release trigger to idle engine, then shut engine off with stop switch. Try to restart engine; if hard to start, open screw another 1/16-turn at a time until enough for consistent starting. When starting speed is satisfactorily adjusted, stop engine and reinstall guide bar, chain, air filter and filter cover. If engine will start readily and saw chain does not turn or only turns slowly, adjustment is correct. If chain turns rapidly with throttle latched, repeat adjustment procedure to set starting speed slower.

MAGNETO. Refer to exploded view of magneto in Fig. HL6. Breaker points and condenser are accessible after removing starter assembly, magneto rotor (flywheel) and breaker box cover.

Condenser capacity should test approximately .02 mfd. Adjust breaker points to 0.015. After reinstalling magneto rotor (flywheel), check magneto armature core to rotor air gap. Air gap should be 0.008-0.012 and can be adjusted using plastic shim stock available as Homelite part No. 24306.

CARBON. Carbon deposits should be removed from muffler and exhaust ports at regular intervals. When scraping carbon, be careful not to damage chamfered edges of exhaust ports or scratch piston. A wooden scraper should be used. Turn engine so that piston is at top dead center so that carbon will not fall into cylinder. Do not attempt to run engine with muffler removed.

LUBRICATION. Engine is lubricated by oil mixed with the fuel. Mix 1/2-pint of Homelite

oil or good grade SAE 30 non-detergent motor oil with each gallon of regular gasoline. Mix fuel and oil thoroughly in a separate container before pouring into fuel tank. Fill chain oiler reservoir with Homelite Bar and Chain oil or with light weight motor oil (not over SAE 30). In cold weather, thin oil with kerosene until it will flow freely.

The clutch needle roller bearing should be cleaned and lubricated after each 100 hours of use. A high temperature grease such as Aero Shell #L-14, Aero Shell #5, Texaco Unitemp #500 or Humble (Esso) Nebula EP1 should be used.

REPAIRS

TIGHTENING TORQUES. Recommended minimum tightening torques for EZ models are listed in the following table; all values are in inch-pounds. To find maximum torque value, add 20 percent to given value.

| | |
|------------------------------------|-----|
| 4/40 Flange bearing | 5 |
| 6/32 Compression release clamp | 20 |
| 6/32 Compression release post nut | 20 |
| 6/32 Breaker box | 20 |
| 6/32 Breaker point adjustable arm | 20 |
| 6/32 Condenser | 20 |
| 8/32 Air filter bracket | 25 |
| 8/32 Connecting rod | 55 |
| 8/32 Throttle handle cover | 35 |
| 8/32 Rewind spring cover | 35 |
| 8/32 Intake manifold (reed spacer) | 20 |
| 8/32 Coil assembly | 20 |
| 8/32 Automatic oiler pump | 35 |
| 8/32 Fuel tank | 35 |
| 10/32 Main bearing retainer screws | 50 |
| 10/32 Stack muffler | 50 |
| 10/32 Muffler body | 50 |
| 10/32 Muffler cap | 35 |
| 10/32 Starter housing | 50 |
| 10/32 Carburetor | 20 |
| 10/32 Starter pawl studs | 50 |
| 10/32 Handle bar | 50 |
| 12/24 Throttle handle | 80 |
| 12/24 Fuel tank to crankcase | 75 |
| 12/24 Drivecase | 75 |
| 1/4-28 Cylinder nuts | 100 |

1. Retaining screws
2. Oil line
3. Fitting
4. Fuel & oil tank
5. Oil pickup line
6. Oil filter
7. Gasket
8. Fuel & oil tank cover
11. Oil line
12. Crankcase
13. Crankshaft seal
15. Dowel pins
16. Roller bearing
18. Crankshaft
17. Woodruff key
19. Retaining screws
20. Bearing retaining washers
21. Ball bearing
22. Snap ring
23. "O" ring
24. Drivecase
25. Guide bar bolts
26. Crankshaft seal
27. "Poizdriv" screw
28. "O" ring
29. Needle rollers (28)
30. Connecting rod
31. Needle bearing
32. Rod cap screws
33. Piston & pin
34. Pin retaining plugs
35. Piston rings
48. Compression release valve
37. Muffler body
38. Muffler base
49. Gasket
40. Muffler cap
50. Piston & pin
41. Muffler baffle
51. Pin retaining plugs
43. Muffler body
44. Spark plug
52. Head land piston ring
45. Cylinder

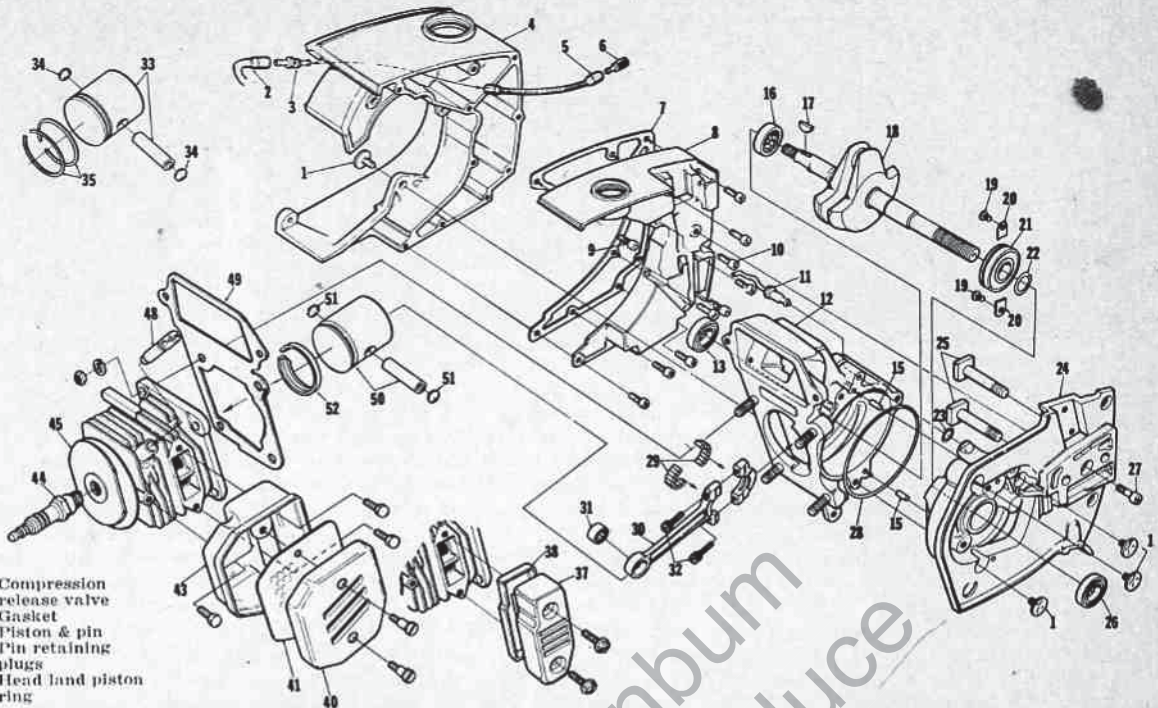

Fig. HL7—Exploded view of EZ Automatic power head and fuel tank assemblies. Model EZ piston (33) and conventional 2-cycle type piston rings (35) are shown at upper right and muffler (37) at lower center; other parts are similar or same as those for model EZ Automatic. Note the head land type ("L" shaped) piston ring (52). When installing new roller bearing (16) in crankcase, refer to Fig. HL9. Crankpin needle rollers are installed as shown in Fig. HL8.

- 5/16-24 Rotor (flywheel) nut150
- 14mm Spark plug120
- Clutch plate180

SPECIAL SERVICE TOOLS. The special service tools for models EZ and EZ Automatic are as follows:

| Tool No. | Description |
|----------|------------------------------------|
| 24299 | Anvil, crankshaft installation. |
| 24300 | Sleeve, crankshaft bearing. |
| 24294 | Plug, needle bearing assembly. |
| 24292 | Plug, seal removal. |
| 24298 | Plug, bearing and seal. |
| 24320 | #3 Pozidriv screwdriver bit. |
| A-24290 | Bracket, rotor remover. |
| A-24060 | Wrench, clutch spanner |
| A-24309 | Jackscrow, crankshaft and bearing. |
| 23136-1 | Body for A-24309. |
| 24295 | Bearing collar for A-24309 |
| 24291 | Sleeve, drivecase seal. |
| 24297 | Sleeve, crankcase seal. |

CONNECTING ROD. Connecting rod and piston assembly can be detached from crankshaft after removing cylinder; refer to Fig. HL8. Be careful to remove all of the 28 loose needle bearing rollers.

Renew connecting rod if bent, twisted or if crankpin bearing surface shows visible wear or is scored. The needle roller bearing for piston pin should be renewed if any roller shows flat spot or if worn so that any two rollers can be separated the width equal to thickness of one roller and if rod is otherwise serviceable. Press on lettered side of bearing cage only when removing and installing bearing.

The crankpin needle rollers should be renewed at each overhaul. To install connecting rod, refer to Fig. HL8. Stick 14 rollers in cap with grease. Support rod cap in crankcase, then place rod over crankpin

Fig. HL8—Installing piston and connecting rod assembly using locally made tool to hold rod cap in position. Tool can be made from flat strip of metal. Using grease, stick 14 rollers in cap and 14 rollers in rod; make sure that match marks on rod and cap are aligned.

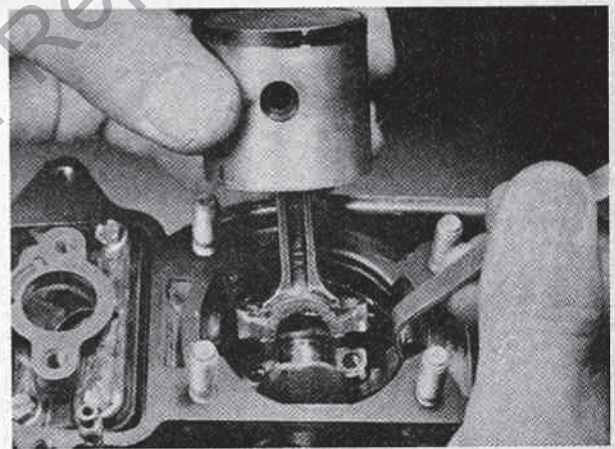

and to cap with match marks aligned and install new retaining cap screws.

PISTON PIN AND RINGS. Model EZ piston has two conventional 2-cycle pinned piston rings. The rings should be renewed whenever engine is disassembled for service.

Model EZ Automatic piston has one Head Land ("L" shaped) ring only. The ring should be renewed if ring end gap exceeds 0.016; desired ring end gap is 0.006-0.0016. The base side of the ring has a cut-out at ring end gap to fit the ring locating pin in piston.

Piston pin in both models is retained in piston by "Rulon" plastic plugs. Insert a plug at each end of pin in piston bore and be sure piston pin and plugs are centered in piston.

Assemble piston to connecting rod so that piston ring locating pin is towards intake side (away from exhaust port).

CYLINDER. The cylinder can be unbolted and removed from crankcase after removing

starter housing and throttle handle. Be careful not to let piston strike crankcase as cylinder is removed.

The cylinder bore is chrome plated and cylinder should be renewed if the chrome plating has worn through exposing the softer base metal. Also inspect for cracks and damage to compression release valve bore.

CRANKSHAFT, BEARINGS AND SEALS. Crankshaft is supported by a roller bearing (16—Fig. HL7) mounted in crankcase bore and by a ball bearing (21) mounted in drivecase (24).

To remove crankshaft, first remove clutch assembly, model EZ Automatic chain oiler pump, starter housing, magneto rotor, throttle handle, cylinder, piston and connecting rod assembly and the fuel/oil tank assembly. Remove retaining screws and separate drivecase and crankshaft from crankcase. Note: "Poizdriv" screwdriver bit only when removing drivecase to fuel tank cover screw

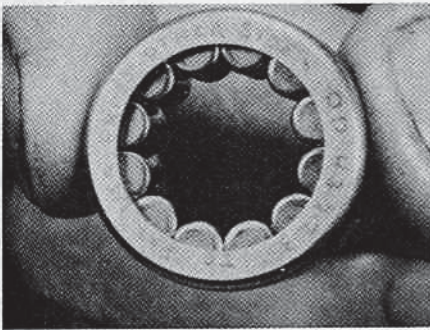

Fig. HL9—Roller type main bearing used at flywheel end of crankshaft is marked on one side, "PRESS OTHER SIDE". Be sure to observe this precaution when installing bearing in crankcase.

(27). Remove the two main bearing retaining screws (19) and special washers (20), then push crankshaft and ball bearing (21) from drivecase. Remove snap ring (22) and press crankshaft from ball bearing.

When reassembling, be sure groove in outer race of ball bearing is towards crankpin and that retaining snap ring is seated in groove on crankshaft. Install new seal (26) in drivecase with lip of seal inward. Using protector sleeve to prevent damage to seal, press the crankshaft and ball bear-

ing into drivecase and install new retaining screws and washers. Install new seal (13) in crankcase with lip of seal inward. Assemble crankcase to crankshaft and drivecase using new "O" ring (28) and protector sleeve to prevent damage of crankcase seal. Be sure bar studs are in place before installing fuel tank.

COMPRESSION RELEASE. When throttle lock is pushed in, a lever connected to throttle lock lifts away from compression release valve (48—Fig. HL7). When engine is cranked, compression forces valve open and compression is partly relieved through port in cylinder. Squeezing throttle trigger after engine is running releases throttle lock, allowing spring (26—Fig. HL2) to snap lever against release valve, closing the valve.

Service of compression release valve usually consists of cleaning valve seat and port in cylinder as carbon may gradually fill the port.

When overhauling engine, cylinder should be inspected for any damage to compression release port.

PYRAMID REED VALVE. A "Delrin" plastic pyramid type reed intake valve seat and four reeds are used. Reeds are retained on pins projecting from the reed seat by a moulded retainer. Inspect reed seat, retainer and reeds for any distortion, excessive wear or other damage.

To reinstall, use a drop of oil to stick each reed to the plastic seat, then push reed retainer down over the seat and reeds. Then install the assembly in crankcase; never install retainer, then attempt to install reed seat and reeds.

AUTOMATIC CHAIN OILER PUMP. Refer to Fig. HL10 for exploded view showing automatic chain oiler pump installation. After removing clutch, the pump can be removed from crankshaft and drivecase. The pump body, flange and plunger are available as a complete pump assembly, less worm gear, only. Check valve parts, cam screw and worm gear are available separately. If pump body and/or plunger are scored or excessively worn, it will be necessary to install a new pump.

CLUTCH. Refer to Fig. HL10 for exploded view of the shoe type clutch. The clutch plate (44) is threaded to crankshaft; turn clutch plate in direction indicated by arrow on face of plate to remove from crankshaft.

If clutch slips with engine running at high speed under load, check clutch shoes for excessive wear. If clutch will not release (chain continues to turn at a normal idle speed), check for broken or weak clutch springs.

Refer to Fig. HL11 for easy method of installing clutch shoes and springs on clutch plate.

1. Fuel cap
2. Gasket
3. Oil cap
4. Gasket
5. Bumper spike
9. Bar adjusting bolt
21. Bar adjusting pin
22. "O" rings
23. Self locking nut
24. Automatic oiler pump
26. Seal
27. Check valve ball
28. Valve spring
29. Gasket
30. Check valve cap
31. Gasket
32. Cam screw
33. Worm gear
35. Inner guide plate
36. Thrust washer
37. Inner race
38. Needle bearing
39. Splined sprocket
40. Clutch drum & sprocket hub
41. Thrust washer
42. Clutch shoes
43. Clutch springs
44. Clutch plate
45. Outer guide plate
46. Drivecase cover
48. Sprocket & drum
49. Thrust washer
50. Oil pump button
51. Plunger nut
52. Plunger rod
53. "O" ring
54. "O" ring
55. Pump plunger
56. Plunger spring
60. Inlet check valve
61. Oil line

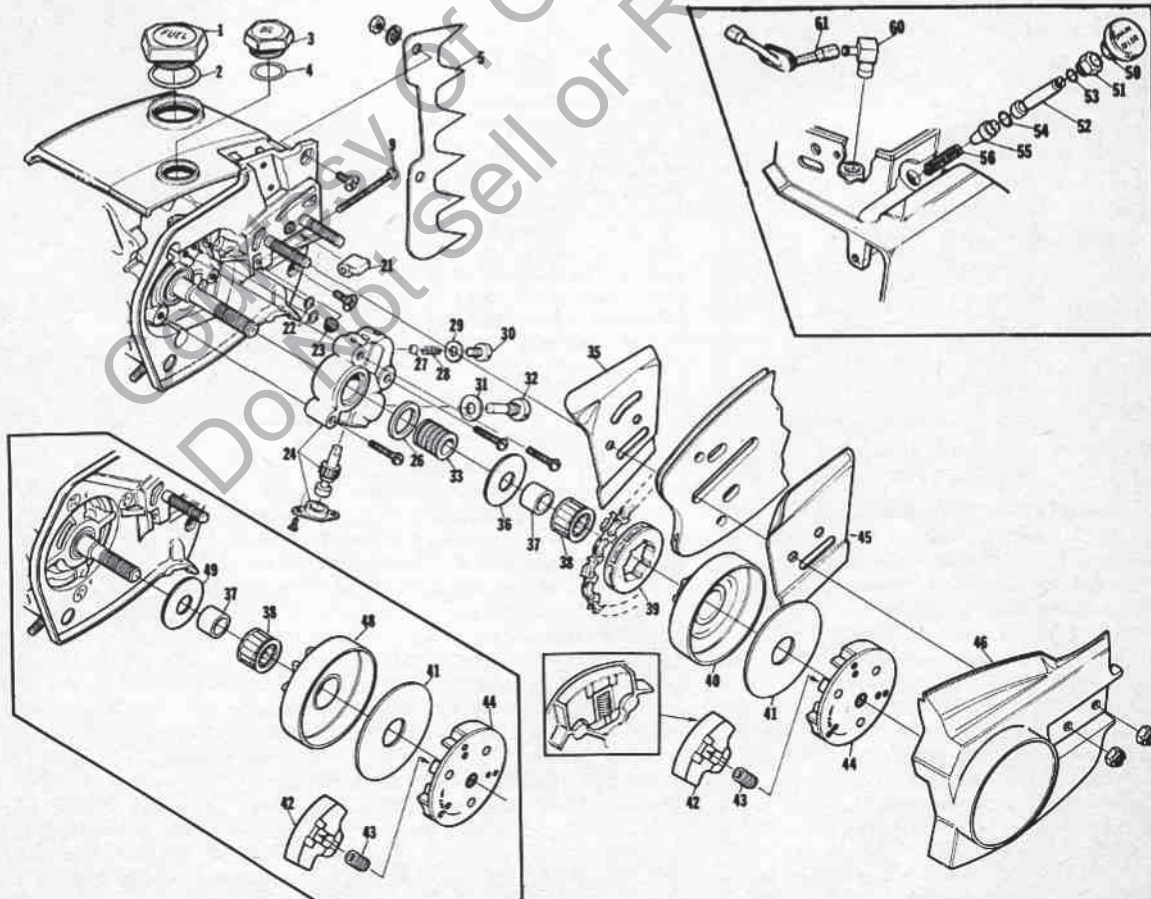

Fig. HL10—Exploded view showing model EZ Automatic chain oiler pump, drive clutch and chain sprocket installation. Model EZ clutch is shown in inset at lower left. Manual chain oiler pump used on both models is shown in inset at upper right; manual pump is mounted in throttle handle.

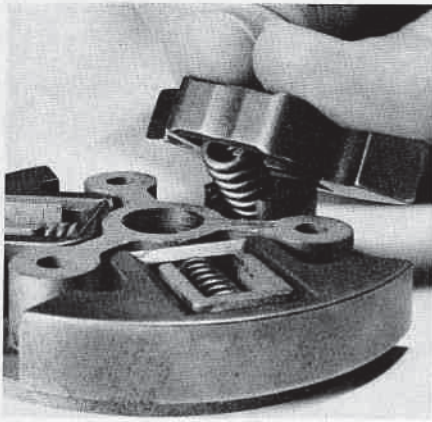

Fig. HL11—View showing easy method of installing clutch shoes and springs. Model EZ clutch is not shown; however, method is same.

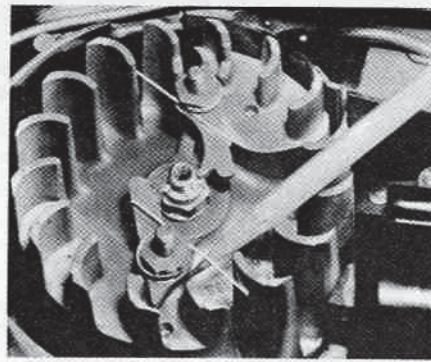

Fig. HL13—View showing proper installation of pawl springs.

If starter pawls were removed, be sure springs are properly engaged with vanes on flywheel as shown in Fig. HL13. When installing new starter rope, knot rope ends as shown in Fig. HL14, pull the knots tight and coat with Duxseal (Homelite part No. 24352).

Use exploded view in Fig. HL12 as re-assembly guide. Before installing cover retaining screws (1), turn cover (2) to pull rope grip against starter housing, then continue turning cover three turns to properly tension the rewind spring.

REWIND STARTER. Exploded view of rewind starter is shown in Fig. HL12. Starter can be removed as a complete unit by removing housing retaining screws (12). To disassemble starter, hold cover (2) while removing retaining screws (1), then allow cover to turn slowly until spring tension is released. Remainder of disassembly is evident from inspection of unit and with reference to exploded view.

Fig. HL14—When installing new starter rope, knot rope ends as shown. Seal rope holes in pulley and coat knots with Duxseal (Homelite part No. 24382)

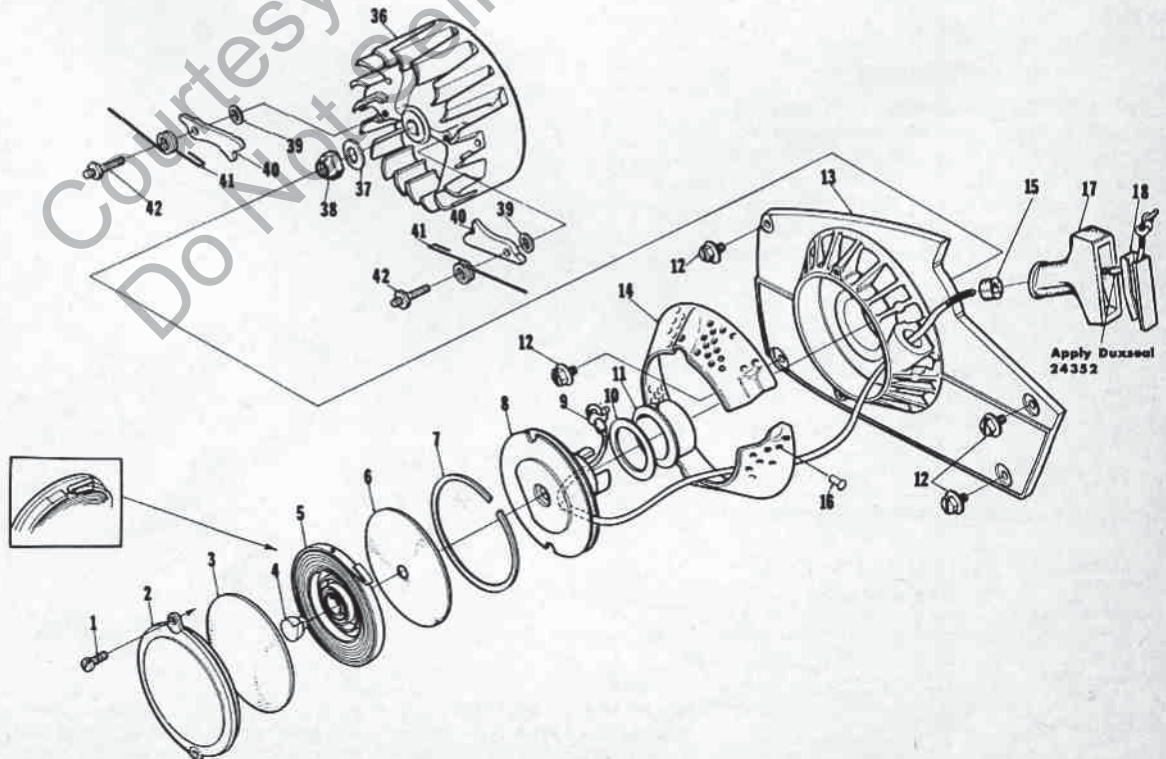
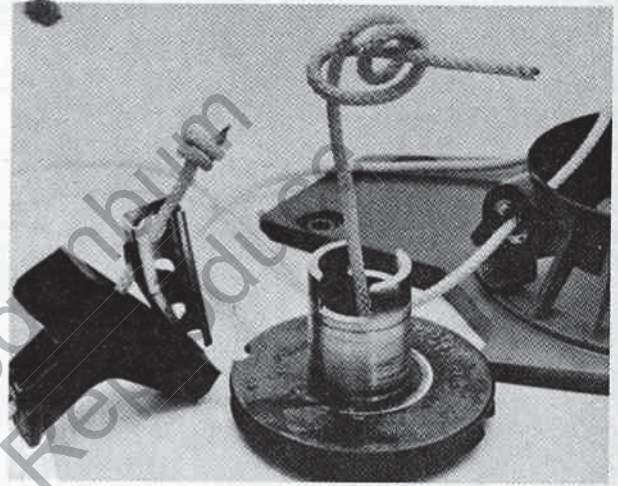

1. Cover screws
2. Starter cover
3. Inner spring shield
4. Spring lock
5. Rewind spring
6. Outer spring shield
7. Snap ring
8. Rope pulley
9. Starter rope
10. Pulley shield
11. Starter cup bushing
12. Hex screw
13. Starter housing
14. Air inlet screen
15. Starter rope bushing
16. Drive studs
17. Rope grip
18. Retaining insert
36. Rotor (flywheel)
37. Flat washer
38. Crankshaft nut
39. Washers
40. Starter pawls
41. Pawl springs
42. Pawl stud

Fig. HL12—Exploded view of EZ rewind starter. When installing pawl springs, refer to Fig. HL13 for correct installation. Starter rope is installed as shown in Fig. HL14. Outer loop of rewind spring (5) engages notch in cover (2) as shown in inset at left.

HOMELITE

A **Textron** DIVISION
 PORT CHESTER, N.Y. U.S.A.

MODEL COVERAGE

| CHAIN SAW MODEL | DESIGN FEATURES |
|---------------------|-----------------|
| XL-12 | A,D,F,G,J |
| XL-15 | A,D,F,H,J |
| Super XL-12 | B,D,F,G,J |
| Super XL-15 | B,E,F,H,J |
| XL Automatic | B,E,F,G,K |
| XL Auto. Gear Drive | B,E,F,H,K |
| Super XL | B,E,F,G,J |
| Super XL Automatic | B,E,F,G,K |
| XL-500 Automatic | C,E,F,G,K |

DESIGN FEATURES CODE

- A—Displacement, 3.3 cu. in.; bore, 1 3/8 in.; stroke, 1 3/8 in.
- B—Displacement, 3.55 cu. in.; bore, 1 1/4 in.; stroke, 1 3/8 in.
- C—Displacement, 4.5 cu. in.; bore, 2 in.; stroke, 1 7/8 in.
- D—Flat reed type intake valve.
- E—Pyramid type reed intake valve, 4 reeds.
- F—Conventional flywheel type magneto.
- G—Direct drive.
- H—Planetary gear drive transmission.
- J—Manual chain oiler only.
- K—Automatic chain oiler only; manual chain oiler pump available as optional accessory.

MAINTENANCE

SPARK PLUG. Depending upon type of spark plug boot and connector, either a "Bantam" (CJ-prefix) or "Shorty" (TJ-prefix) spark plug is used.

Early production models XL 12 and Super XL-12 were equipped with a Champion TJ-8J spark plug and a TJ-6J was recommended for other early models.

Late production models XL-12, Super XL-12 and XL-15 are equipped with a Champion CJ-8 spark plug and other models use a CJ-6. To convert earlier models to use either the CJ-8 or CJ-6, install a new terminal (Homelite part No. A-33055) on plug wire.

- 1. Gasket
- 2. Insulator
- 3. Fuel line
- 4. Carburetor
- 5. Cotter pin
- 6. Choke rod
- 8. Filter cover
- 9. Nut
- 10. Snap ring
- 11. Filter element
- 12. Gasket
- 13. Gasket
- 14. Bracket
- 15. Throttle rod
- 18. Boot
- 19. Throttle latch pin
- 20. Spring
- 23. Snap ring
- 24. Throttle trigger
- 26. Grommet
- 27. Choke button
- 28. Check valve
- 29. Air box

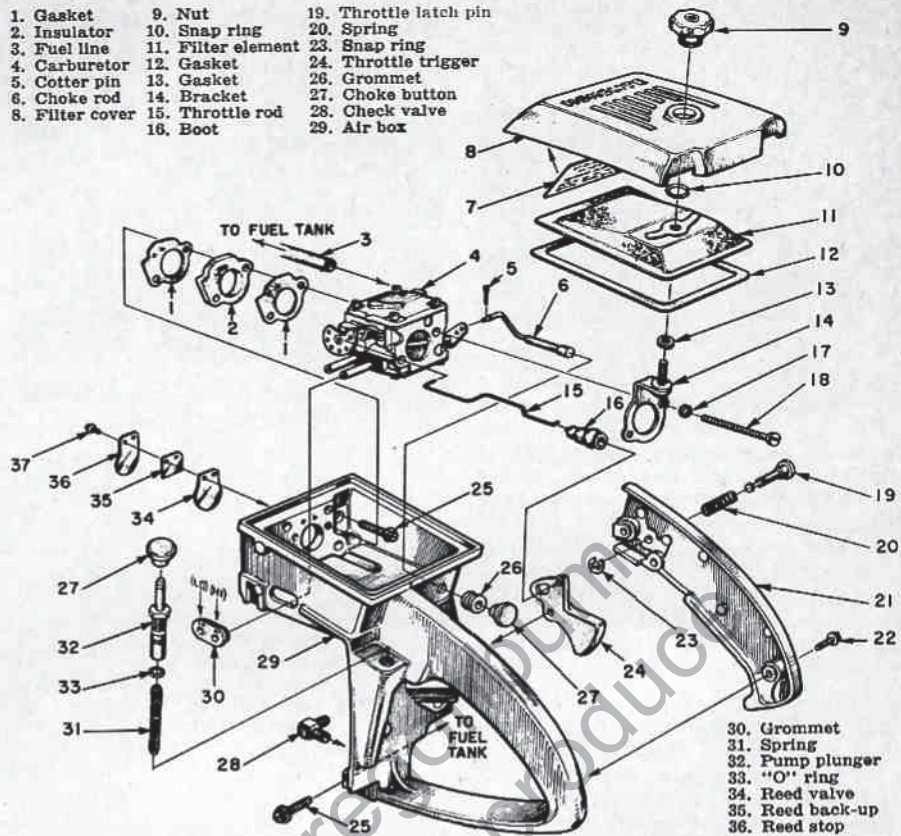

Fig. HL30 — Exploded view of air box (throttle handle) and related parts on models with flat reed intake valve (34). Refer to Fig. HL30A for models equipped with pyramid reed valve.

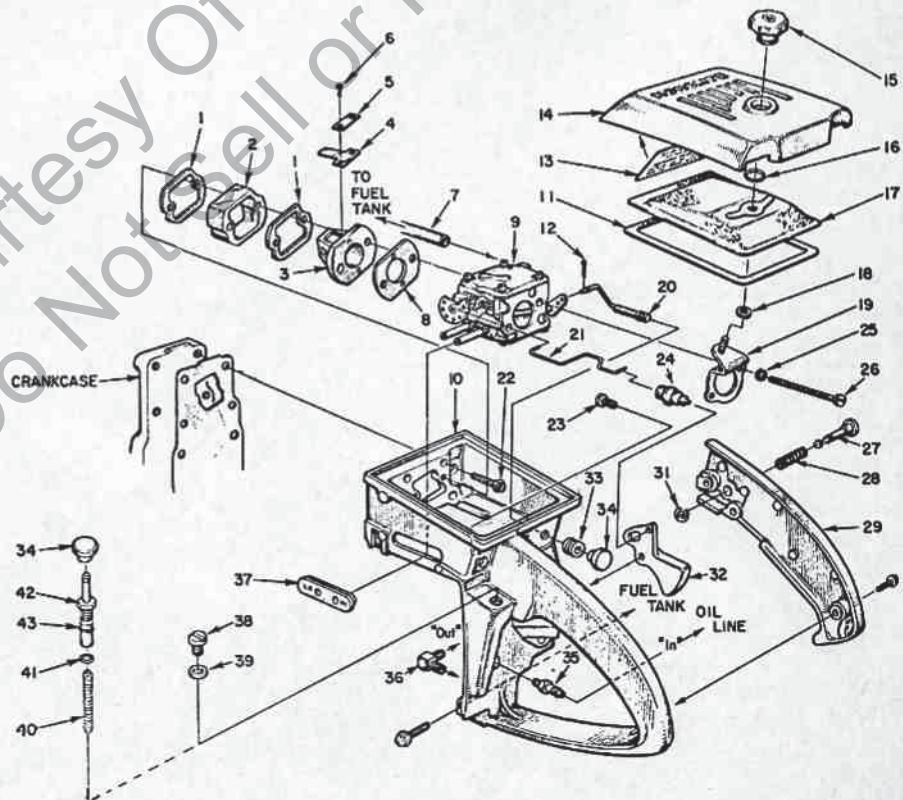

Fig. HL30A — Exploded view of air box and throttle handle assembly for models equipped with pyramid reed type intake valve. Idle speed adjusting screw (23) is located in air box instead of on carburetor body; remove idle speed adjusting screw (4—Fig. HL31) and spring from new service carburetor before installing carburetor on these models. Early type aluminum reed seat is shown; refer to Fig. HL30B for late type plastic (Delrin) seat and moulded reed retainer.

- 1. Gaskets
- 2. Spacer
- 3. Reed seat
- 4. Valve reeds (4)
- 5. Retaining plates
- 7. Fuel line
- 8. Gasket
- 9. Carburetor
- 10. Air box
- 11. Gasket
- 14. Cover
- 17. Filter
- 18. Gasket
- 19. Bracket
- 20. Choke rod
- 21. Throttle rod
- 23. Idle speed screw
- 24. Boot
- 27. Throttle latch pin
- 28. Spring
- 29. Handle cover
- 31. Snap ring
- 32. Throttle trigger
- 33. Grommet
- 35. "In" check valve
- 36. "Out" check valve
- 37. Grommet
- 38. Plug (AO models)
- 39. Gasket
- 40. Spring (manual oiler)
- 41. "O" ring
- 42. Manual pump plunger
- 43. "O" ring

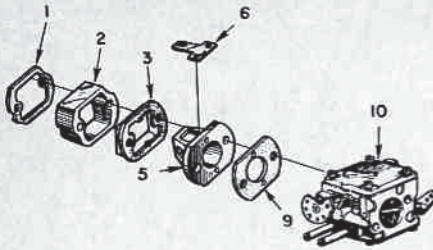

Fig. HL30B—View showing late type Delrin plastic reed seat (5) and moulded reed retainer (3). Reeds (6) are held on pins protruding from seat by the retainer. Refer to text for assembly instructions.

- 1. Gasket
- 2. Spacer
- 3. Reed retainer
- 4. Reed seat
- 5. Gasket
- 6. Reeds (4)
- 9. Gasket
- 10. Carburetor

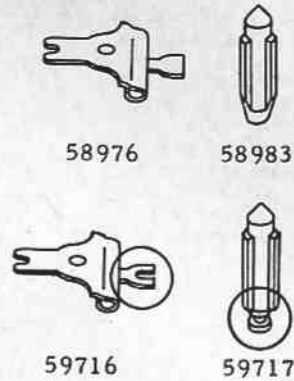
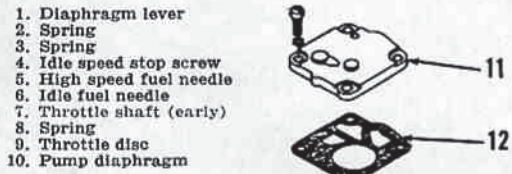
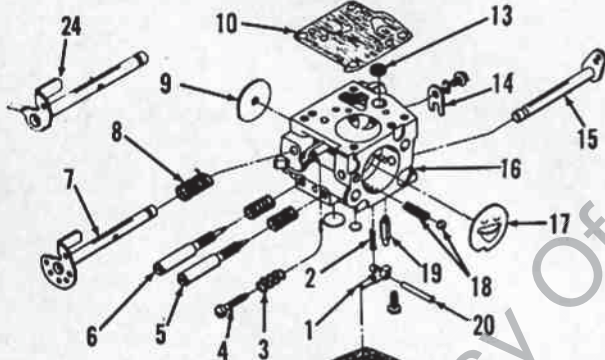

Fig. HL31A — Late type fuel inlet valve (59717) and lever (59716) are notched for better valve control and are interchangeable as a set with early valve (58983) and lever (58976) shown at top.



- 1. Diaphragm lever
- 2. Spring
- 3. Spring
- 4. Idle speed stop screw
- 5. High speed fuel needle
- 6. Idle fuel needle
- 7. Throttle shaft (early)
- 8. Spring
- 9. Throttle disc
- 10. Pump diaphragm



- 11. Pump cover
- 12. Gasket
- 13. Fuel screen
- 14. Shaft retainer
- 15. Choke shaft
- 16. Carburetor body
- 17. Choke disc
- 18. Choke detent & spring
- 19. Inlet valve
- 20. Lever pin
- 21. Gasket
- 22. Fuel diaphragm
- 23. Cover
- 24. Throttle shaft (late)

Fig. HL31 — Exploded view of typical Tillotson Series HS diaphragm type carburetor used on XL models. Idle speed stop screw (4) is not used on some models; refer to (23—Fig. HL30A).

The valves and levers are interchangeable; however, they must be installed in sets.

NOTE: If air filter cover gasket (12—Fig. HL30) becomes damaged when removed to service carburetor or air filter element, install new gasket as follows: Carefully remove old gasket from air box and be sure that surface is free of all saw dust, oil, etc. Apply "3M" cement to new gasket and carefully place gasket, adhesive side down, on lip around carburetor chamber.

For initial adjustment of carburetor, back idle speed adjustment screw out until it clears throttle stop; then, turn screw back in until it contacts stop plus 3/4 additional turn. Open idle fuel needle and main fuel needle one full turn each.

Make final adjustments with engine warm and running. Adjust idle fuel needle so that engine idles smoothly; then, adjust idle stop screw so that engine idles at just below clutch engagement speed (approximately 2600 RPM). Check engine for proper acceleration and open idle fuel needle slightly if necessary for proper acceleration. Adjust main fuel needle only while cutting under load so that engine runs at highest speed obtainable without excessive smoke. NOTE: Idle and high speed fuel adjustments are interdependent; resetting one adjustment usually requires that the other fuel mixture needle be readjusted also.

CARBURETOR (WALBRO). A Walbro model SDC-8 carburetor is used as alternate installation, replacing the Tillotson HS-4D, on some late production models. Refer to Fig. HL31B for exploded view of the Walbro carburetor. For carburetor fuel mixture and idle speed adjustments, refer to previous paragraph for Tillotson carburetor.

To overhaul Walbro carburetor, refer to

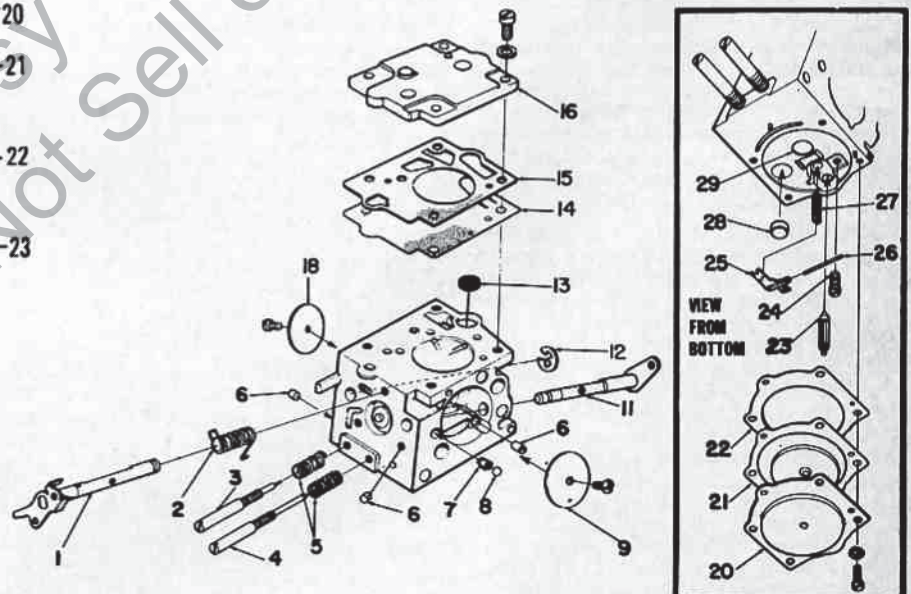

Fig. HL31B—Exploded view of Walbro series SDC carburetor. Inset box at right shows view from bottom of carburetor. Plugs (6) close off channels used for accelerator pump pulse and fuel passages; the model SDC-8 carburetor is not equipped with accelerator pump.

- 1. Throttle shaft
- 2. Throttle return spring
- 3. Idle fuel needle
- 4. Main fuel needle
- 5. Friction springs
- 6. Channel plugs
- 7. Choke detent spring
- 8. Choke detent ball
- 9. Choke disc
- 10. Choke shaft and lever
- 11. Throttle shaft clip
- 12. Throttle shaft
- 13. Fuel screen
- 14. Fuel pump diaphragm
- 15. Diaphragm gasket
- 16. Fuel pump cover
- 18. Throttle disc
- 20. Metering diaphragm cover
- 21. Metering diaphragm
- 22. Diaphragm gasket
- 23. Inlet needle valve
- 24. Pin retaining screw
- 25. Metering lever
- 26. Lever pin
- 27. Lever spring
- 28. Expansion plug
- 29. Expansion plug

For heavy duty service, a Champion UTJ-11P gold-palladium tip park plug can be used with good results on all models.

For all models, set spark plug electrode gap to 0.025.

CARBURETOR (TILLOTSON). Refer to Fig. HL31 for typical Tillotson Series HS diaphragm type carburetor with integral fuel pump that is used on Model XL chain saws. Models HS-1A, HS-4A, HS-4B, HS-5A, HS-5B and HS-5C have been used in production. A model HS-4C can be used as a service replacement for the above carburetors. Late production models use an HS-4D carburetor having a different throttle shaft (24).

Late type inlet valve and valve lever are notched (See Fig. HL-31A), whereas ends of early type valve and lever were plain.

Fig. HL31B for disassembly and reassembly guide. Adjust fuel diaphragm lever (25) by bending lever as necessary so that lever is flush with bosses cast on carburetor body at each side of lever. If necessary to remove plugs (28 and 29) for cleaning passages, carefully drill through plug with small diameter drill, insert pin in drilled hole and pry plug out. Take care not to drill any deeper than thickness of plug. NOTE: Do not blow compressed air through main nozzle check valve as this will damage the rubber valve. If valve has been removed or damaged, it will be necessary to install a check valve repair kit (Homelite part No. 65386) using a special installation tool (Homelite tool No. 24173).

MAGNETO. A Wico or Phelon flywheel type magneto with external armature and ignition coil is used. Units equipped with Phelon magneto will have a letter "P" stamped after the serial number. The Wico and Phelon magnetos are similarly constructed, so care should be taken to properly identify magneto before ordering service parts. Breaker points and condenser are located behind flywheel.

Armature core and stator plate are riveted together and are serviced only as a unit. Stator plate fits firmly on shoulder of crankcase; hence, armature air gap is non-adjustable.

Late production Wico magneto stator plates are built to retain a felt seal (43—Fig. HL34); the seal cannot be used with early production Wico stator plates. All Phelon stator plates are built to retain the felt seal (43).

Magneto stator plate has slotted mounting holes, and should be rotated as far clockwise as possible before tightening mounting screws to obtain correct ignition timing of 30 degrees BTDC. Set breaker point gap to 0.015. Condenser capacity should test 0.16-0.20 mfd. CAUTION: Be careful when installing breaker points not to bend tension spring any more than necessary; if spring is bent excessively, spring tension may be reduced causing improper breaker point operation. Late Wico units have a retaining clip (35—Fig. HL34) and flat washer to secure breaker arm on pivot post.

LUBRICATION. Engine is lubricated by oil mixed with fuel. Thoroughly mix oil and gasoline in separate container. Mix 1/2-pint of Homelite motor oil or good grade SAE 30 motor oil in each gallon of regular gasoline. (16:1 mixture).

Fill chain oiler reservoir with Homelite Bar and Chain oil or a light weight oil (no heavier than SAE 30). In cold weather, chain oil can be diluted with kerosene to allow easier flow of oil through pump and lines.

On early model XL-12, the clutch drum and sprocket assembly should be removed and a few drops of oil placed on the Oilite bushings occasionally. All other models (and converted early production XL-12) have needle bearing instead of Oilite bushing.

CARBON. Muffler and cylinder exhaust ports should be cleaned periodically to prevent loss of power due to carbon build up. Remove muffler and scrape free of carbon. With muffler removed, turn engine so that piston is at top dead center and carefully remove carbon from exhaust ports with a wooden scraper. Be careful not to damage chamfered edges of exhaust ports or to scratch piston. Do not run engine with muffler removed.

Fig. HL34 — Exploded view of Wico magneto used on some models. Phelon magneto used on other models is of similar construction. Felt seal (43) cannot be used on early Wico magnetos. Connect condenser and ignition coil low tension leads as indicated by letters "B" and "C".

- 27. Magneto rotor (flywheel)
- 28. Condenser
- 31. Breaker box cover
- 32. Terminal block
- 33. Point set
- 34. Washer
- 35. Clip
- 37. Gasket
- 38. Cover spring
- 40. Armature core & stator plate
- 41. Gasket
- 42. Woodruff key
- 43. Felt seal
- 44. Ignition coil
- 45. High tension lead
- 47. Spark plug boot
- 49. Coil clip

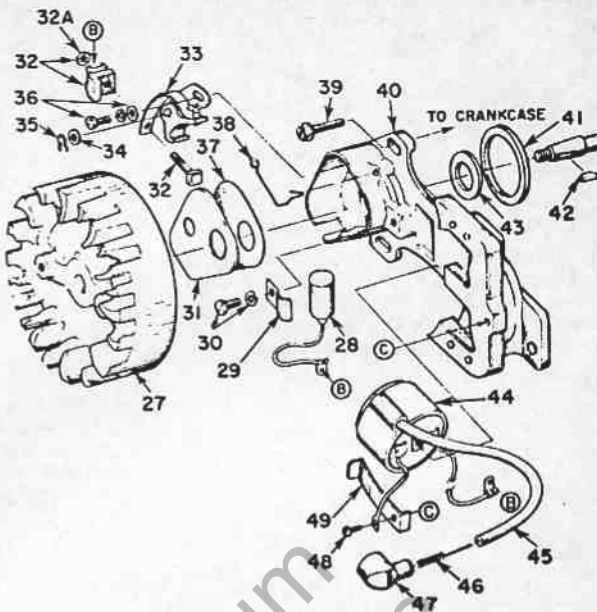

REPAIRS

TIGHTENING TORQUE VALUES. Tightening torque values for XL-12/XL-500 Automatic units are as follows: NOTE: All values are in inch-pounds; minimum torque value is given. To find maximum torque value, add 20% to value given.

| | |
|--|-----|
| 4/40 Reed & stop to chamber | 5 |
| 4/20 Oil line plate or shield to tank .. | 5 |
| 8/32 Throttle handle cover | 40 |
| 8/36 Connecting rod | 55 |
| 10/32 Muffler cap | 50 |
| 10/32 Bearing retainer | 55 |
| 10/32 Screen to rotor | 50 |
| 10/32 Drivecase cover | 55 |
| 10/32 Pulley to fan housing | 50 |
| 10/32 Flanged inner race for pulley | 55 |
| 10/32 Carburetor to chamber | 50 |
| 12/24 Handle bar to fuel tank | 80 |
| 12/24 Bracket to drivecase | 80 |
| 12/24 Stator to crankcase and cylinder.. | 80 |
| 12/24 Drivecase to crankcase | 80 |
| 12/24 Carburetor chamber to fuel tank.. | 80 |
| 12/24 Muffler to cylinder | 80 |
| 1/4-20 Fuel tank to crankcase | 80 |
| 12/24 Fan housing to fuel tank | 80 |
| 1/4-28 Cylinder nuts | 100 |
| 12/24 Pawl studs to rotor | 80 |
| 1/4-20 Handle bar to bracket | 100 |
| 1/4-20 Bumper screws | 80 |
| 3/8 24 Clutch nut | 150 |
| 5/8-32 Clutch nut | 150 |
| 5/16-24 Rotor nut | 150 |
| 1/2-20 Clutch to crankshaft | 150 |
| 14mm Spark plug | 250 |
| Clutch spider | 180 |

HOMELITE SERVICE TOOLS. Listed below are Homelite tool numbers, tool description and model application of tools for servicing XL-12 through XL-500 series chain saws.

| Tool No. | Description & Model Usage |
|----------|--|
| 22828 | Pliers, piston pin snap ring, all models. |
| A-23949 | Remover, piston pin with Spirol pin at exhaust side of piston. |

| | |
|-----------|--|
| 23756 | Plug, connecting rod bearing removal and installation, all models. |
| A-23960 | Remover and locking bracket, rotor (flywheel), all models. |
| 23757 | Plug, needle roller type main bearing installation, all models. |
| 23758 | Plug, crankcase seal installation, all models; drivecase seal installation, models XL-12, XL-15 & S/XL-12. |
| 23759 | Sleeve, crankcase seal protector, all models; drivecase seal protector, models XL-12, XL-15 & S/XL-12. |
| 23800 | Sleeve, crankcase seal installation, all models; drivecase seal installation, models XL-12, XL-15 & S/XL-12. |
| 23843 | Sleeve, drivecase seal installation, all models except XL-12, XL-15 & S/XL-12. |
| 23844 | Sleeve, drivecase seal protector, all models except XL-12, XL-15 & S/XL-12. |
| 23845 | Plug, drivecase seal installation, all models except XL-12, XL-15 & S/XL-12. |
| 23846 | Anvil, crankshaft installation, all models except XL 12, XL-15 & S/XL-12. |
| A-23858 | Tool, crankcase to drivecase installation, model XL-500. |
| A-23137 | Jackscrew, crankshaft assembly & installation, all models except XL-12, XL-15 & S/XL-12. |
| 22820-1 | Bearing collar for A-23137. |
| 22136 | Body for A-23137. |
| A-23841-A | Wrench, guide bar stud insert, all models except XL-12, XL-15 & S/XL-12. |
| A 23934 | Wrench, clutch plate removal and installation, all late production. |
| A-23696 | Wrench, clutch spider removal and installation, all early production; sun gear removal on gear drive models. |

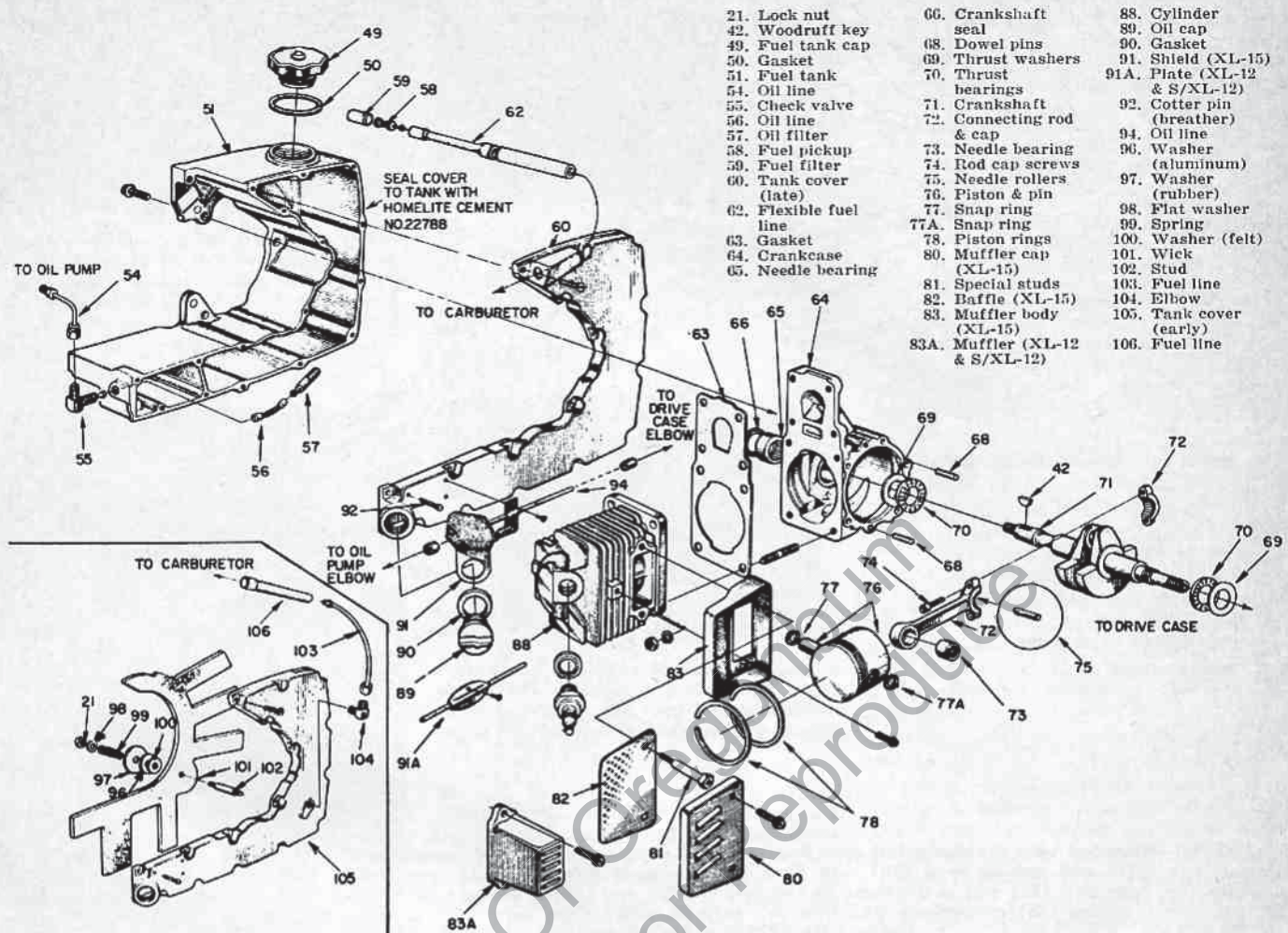

Fig. HL35—Exploded view showing powerhead and fuel tank construction of models XL-12, Super XL-12 and XL-15. refer to Fig. HL35A for other models. Early wick type fuel pickup and tank cover are shown in inset; beginning with serial No. 2188611, flexible hose (62) type pickup is used. Dowel pins (68) are used on later models; refer to text. Single piece muffler (83A) is used on XL-12 and Super XL-12; XL-15 is fitted with three piece muffler (80, 82 & 83).

- A-78 SNAP-ON tool, remover for clutch drum needle roller bearing on all models.
- 23819 Plug, clutch drum needle bearing installation, all direct drive models.
- 27773 Plug, clutch drum needle bearing installation, all gear drive models.
- 23665 Pliers, planetary gear drive snap ring, all gear drive models.
- 23772 Plug, planetary gear drive needle bearing, all gear drive models.
- A-23792 Sprocket holder, all gear drive models.

CONNECTING ROD. Connecting rod and piston assembly can be removed after removing cylinder from crankcase. Refer to Fig. HL37. Be careful to remove all of the loose needle rollers when detaching rod from crankpin. Early models have 28 loose needle rollers; starting with serial No. 207-1277, 31 needle rollers are used. Note: A different crankshaft and connecting rod are used on late models with 31 needle rollers.

Renew connecting rod if bent or twisted, or if crankpin bearing surface is scored,

burned or excessively worn. The caged needle roller piston pin bearing can be renewed by pressing old bearing out and pressing new bearing in with Homelite tool No. 23756. Press on lettered end of bearing cage only.

It is recommended that the crankpin needle rollers be renewed as a set whenever engine is disassembled for service. On early models with 28 needle rollers, stick 14 needle rollers in the rod and remaining 14 needle rollers in rod cap with light grease or beeswax. On late models with 31 needle rollers, stick 16 rollers in rod and 15 rollers in rod cap. Assemble rod to cap with match marks aligned, and with open end of piston pin towards flywheel side of engine. Wiggle the rod as cap retaining screws are being tightened to align the fractured mating surfaces of rod and cap.

PISTON, PIN AND RINGS. The piston is fitted with two pinned compression rings. Renew piston if scored, cracked or excessively worn, or if ring side clearance in top ring groove exceeds 0.0035.

Recommended piston ring end gap is 0.070-0.080; maximum allowable ring end gap is 0.085. Desired ring side clearance in groove is 0.002-0.003.

- | | | |
|------------------------|--------------------------------|------------------------------|
| 21. Lock nut | 66. Crankshaft seal | 88. Cylinder |
| 42. Woodruff key | 68. Dowel pins | 89. Oil cap |
| 49. Fuel tank cap | 69. Thrust washers | 90. Gasket |
| 50. Gasket | 70. Thrust bearings | 91. Shield (XL-15) |
| 51. Fuel tank | 71. Crankshaft | 91A. Plate (XL-12 & S/XL-12) |
| 54. Oil line | 72. Connecting rod & cap | 92. Cotter pin (breather) |
| 55. Check valve | 73. Needle bearing | 94. Oil line |
| 56. Oil line | 74. Rod cap screws | 96. Washer (aluminum) |
| 57. Oil filter | 75. Needle rollers | 97. Washer (rubber) |
| 58. Fuel pickup | 76. Piston & pin | 98. Flat washer |
| 59. Fuel filter | 77. Snap ring | 99. Spring |
| 60. Tank cover (late) | 78. Piston rings | 100. Washer (felt) |
| 62. Flexible fuel line | 80. Muffler cap (XL-15) | 101. Wick |
| 63. Gasket | 81. Special studs | 102. Stud |
| 64. Crankcase | 82. Baffle (XL-15) | 103. Fuel line |
| 65. Needle bearing | 83. Muffler body (XL-15) | 104. Elbow |
| | 83A. Muffler (XL-12 & S/XL-12) | 105. Tank cover (early) |
| | | 106. Fuel line |

Piston, pin and rings are available in standard size only. Piston and pin are available in a matched set, and are not available separately.

On early production units, piston pin is retained in piston by two Waldes Truarc snap rings. Later production pistons have a Spirol pin through piston boss at exhaust side and a Waldes Truarc snap ring at intake side of piston. Latest type piston has a wire section snap ring (which should not be removed) at exhaust side of piston and a Waldes Truarc snap ring at intake side; exhaust end of piston pin is tapered to fit against the wire section ring.

To remove piston pin on all models, remove the snap ring at intake side of piston using snap ring pliers (Homelite tool No. 22828). On piston with Spirol pin at exhaust side, drive pin from piston and rod with slotted driver (Homelite tool No. A-23949). On all other models, insert a $\frac{3}{16}$ -inch pin through snap ring at exhaust side and drive piston pin out as shown in Fig. HL39.

When reassembling piston to connecting rod, be sure to install closed end of piston pin towards exhaust side of piston (away from piston ring locating pin). Fit the Waldes

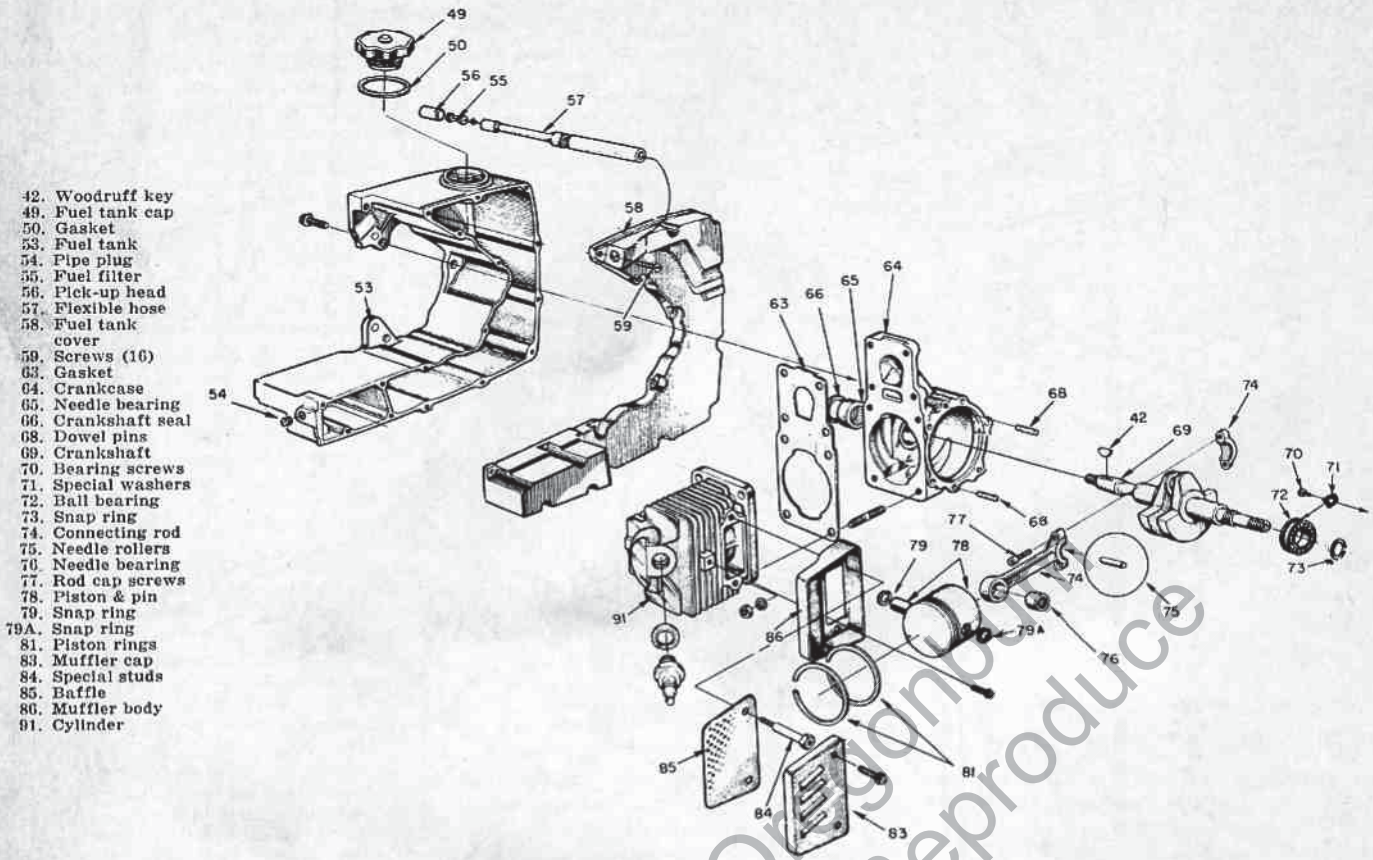

Fig. HL35A—Exploded view showing latest type fuel tank and later construction of power head; refer to Fig. HL35 for early units. Flexible hose (57) and pick-up head (55) with filter (56) are used instead of wick type pick-up. Ball bearing (72) is retained on crankshaft by snap ring (73) and in drivecase by two screws (70) and special washers (71); refer to Fig. HL35B. Latest models have 31 loose needle rollers (75) at crankpin; earlier models have 28 rollers. Tank cover (58) is sealed to tank (53) with cement (Homelite part No. 22788) and is retained with 16 screws (59).

Truarc snap ring in groove of pin bore with sharp edge out and turn ring gap towards closed end of piston.

CRANKSHAFT AND BEARINGS. On models XL-12, Super XL-12 and XL-15, the crankshaft is supported in two caged needle roller bearings and crankshaft end play is controlled by a roller bearing and hardened steel thrust washer on each end of the shaft. Refer to Fig. HL36. On all other models, flywheel end of crankshaft is supported in a needle bearing in crankcase and drive end is supported in a ball bearing located in drive case; end play is controlled by the ball bearing.

Maximum allowable crankshaft end play on models with thrust bearings (Fig. HL36) is 0.0202; renew thrust bearings if end play is excessive. Normal end play is approximately 0.010.

Renew the crankshaft if any of the main bearing, crankpin bearing or thrust bearing surfaces or sealing surfaces are scored, burned or excessively worn. Renew the drivecase ball bearing if excessively loose or rough (lumpy). Also, reject crankshaft if flywheel keyway is beat out or if threads are badly damaged.

CYLINDER. The cylinder bore is chrome plated. Renew the cylinder if chrome plating is worn away exposing the softer base metal.

CRANKCASE, DRIVECASE AND SEALS. On all models, crankshaft seals can be renewed without disassembling crankcase.

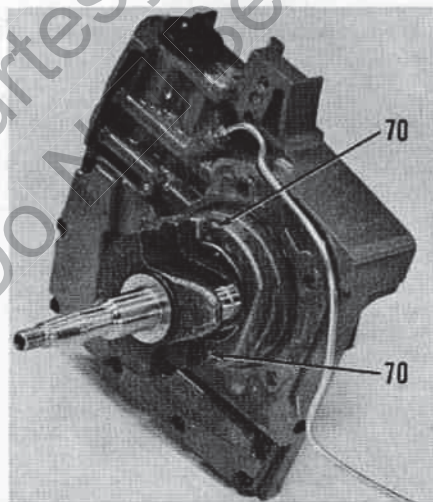

Fig. HL35B—View showing crankcase removed from drive case and crankshaft on models equipped with ball bearing at drive end of crankshaft. To remove crankshaft from drive case, bearing retaining screws (70) must first be removed

drive case and crankshaft unit. With magneto armature and core assembly removed, pry seal from crankcase. Install new seal over crankshaft with lip of seal inward, then using driver sleeve, drive seal into

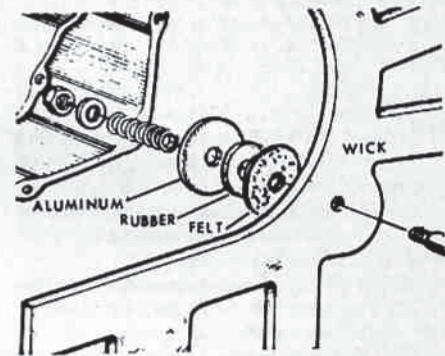

Fig. HL35C—View showing proper assembly of wick, felt washer, rubber washer and aluminum washer on pickup stud.

crankcase. Seal in drivecase can be pried out after removing clutch assembly and, on models so equipped, the automatic chain oiler pump. Install seal with lip inward and drive into position with sleeve. Note: Use of seal protectors is recommended; if protectors are not available, wrap threads on crankshaft with thin plastic tape to prevent damage to seal lips.

Crankcase can be removed from crankshaft and drivecase after removing cylinder, piston and connecting rod and removing retaining screws. On models XL-12, XL-15 and Super XL-12, crankshaft can be withdrawn from drivecase. On all other models,

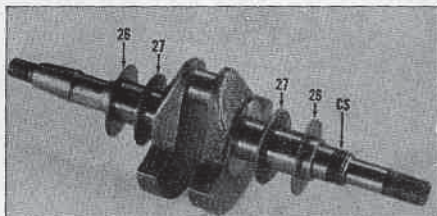

Fig. HL36—Be sure the steel thrust washers (26) are to outside of thrust bearings (27) when installing crankshaft on models XL-12, Super XL-12 and XL-15. Other models do not use thrust washers or thrust bearings.



Fig. HL39 — After removing snap rings, the piston pin can be tapped out using a 3/16-inch rod as shown or, on pistons with Spirol pin at exhaust side, by driving piston pin out with slotted driver (Homelite tool No. 23949).

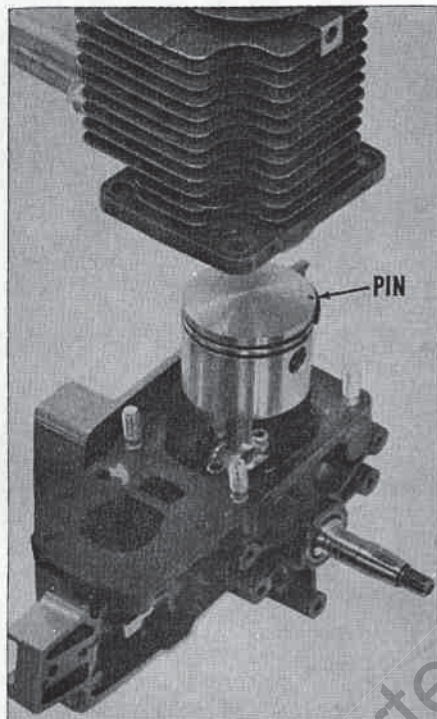

Fig. HL37—Piston and connecting rod assembly can be removed from crankpin after removing cylinder from crankcase. Note piston ring locating pin on intake side of piston.

remove the two bearing retaining screws (70—Fig. HL35A) and special washers (71), then press crankshaft and ball bearing (72) from drivecase. Remove snap ring (73), then press crankshaft out of the ball bearing.

Inspect the needle roller bearing in crankcase, and on models XL-12, XL-15 and Super XL-12, the needle roller bearing in drivecase. Bearings should be renewed if any needle roller has flat spot or is otherwise damaged, or if rollers are worn so that two rollers may be separated a width equal to thickness of one roller. Always press against lettered end of bearing cage when removing and installing needle roller bearings. Needle roller bearings should be installed using appropriate installation plug.

Install new ball bearing on crankshaft using jackscrew or by supporting crankshaft at crank throw and installing bearing in a press. Groove in outer race of bearing must be towards crankpin.

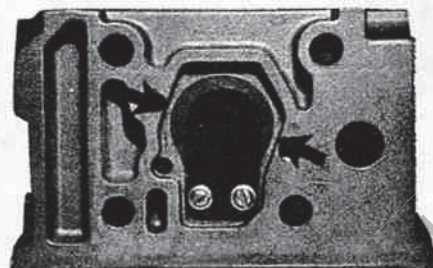

Fig. HL39B — When installing reed valve on air box (models with flat reed intake valve only), be sure reed is centered between the two points indicated by arrows.

Renew crankshaft seals before assembling crankshaft, crankcase and drivecase. Using installation plug, press seal into position with lip to inside of crankcase. On models XL 12, XL-15 and Super XL-15, install thrust bearings on crankshaft next to crankpin throw, then install the hardened steel thrust washers at outer side of each thrust bearing. On all other models, first assemble crankshaft and drivecase by placing seal protector on crankshaft, then pulling crankshaft and ball bearing into drivecase with jackscrew and adapters. Install two NEW bearing retaining screws and lockwashers. On models XL-12, XL-15 and Super XL-12, place seal protector on crankshaft and insert crankshaft in crankcase. Then, on all models, assemble crankcase to drivecase using new gasket. Note: On early production, crankcase was sealed to drivecase with an "O" ring; however, use of "O" ring has been discontinued and a gasket, rather than an "O" ring, should be used on all models.

On all late production models, crankcase is fitted with two dowel pins to provide a more positive alignment of crankcase and drivecase. Service crankcases are drilled for dowel pins, but dowel pins are not installed so that crankcase can be used with early type drivecase not drilled for dowels. If renewing late type crankcase fitted with dowel pins, two new dowel pins must be obtained and installed in new crankcase; install dowel pins so they protrude 0.165-0.180 from crankcase.

FLAT REED VALVE. The reed valve is attached to the carburetor air box as shown in Fig. HL30, and is accessible after removing air box from crankcase.

Check the reed seating surface on air box to be sure it is free of nicks, chips or burrs. Renew valve reed if rusted, pitted or

cracked, or if it does not seat flatly against its seat.

The reed stop is curved so that measurement of reed lift distance is not practical. However, be sure that reed is centered over opening in air box and reed stop is aligned with reed as shown in Fig. HL39B. Clean the screw threads and apply Loctite to threads before installing screws.

NOTE: If air box has been removed to service reed valve, inspect gasket (63—Fig. HL35) between air box and crankcase. If gasket is damaged and cylinder is not being removed for other purposes, it is suggested that the exposed part of the old gasket be carefully removed and the new gasket be cut to fit between the air box and crankcase. Also, refer to note in CARBURETOR paragraph in MAINTENANCE section.

PYRAMID REED VALVE. All models except XL-12, XL-15 and Super XL-12 are equipped with a pyramid reed type intake valve with four reeds. Early production reed seat was made of aluminum and reeds were retained to seat by spring plates and screws.

Late production reed seat (see Fig. HL-30B) is made of Delrin plastic. The reeds fit onto pins protruding from the plastic seat and are held in place by a moulded retainer, eliminating the retaining spring plates and screws.

Reeds, spring plates and retaining screws are available for servicing the early type aluminum reed seat. However, if the seat is worn or damaged beyond further use, the Delrin seat and moulded retainer is used as replacement.

When assembling reeds to aluminum seat, apply Loctite to retaining screws to keep them from working loose. Renew the spacer gaskets and carburetor gasket and install the spacer, reed seat assembly and carburetor as in Fig. HL30A.

To assemble and install Delrin reed seat and reeds, proceed as follows: Fit the reed retainer (3—Fig. HL30B) into spacer (2) so that the pin on retainer clears cut-out in spacer. Using a drop of oil under each reed, stick the reeds to pyramid seat so that holes in reeds fit over the pins moulded into seat. Place the retainer and spacer over the reeds and seat so that all parts are locked together, then install the valve assembly and carburetor with new gaskets (1 & 9).

CLUTCH. Refer to Fig. HL40 for exploded view of typical direct drive clutch assembly and to Fig. HL41A for planetary gear drive models. Both illustrations show late type clutch assembly using three compression springs (11) to hold shoes retracted in plate (10) and in insets at lower left corner, the early type clutch using garter type springs (11A) to hold shoes to spider (10A). The early type clutch (inset) and late type clutch are interchangeable as an assembly. Clutch plate (10) or spider (10A) is threaded to crankshaft.

If clutch will not disengage (chain continues to turn) with engine at idle speed, check for broken, weak or improperly installed clutch springs. If clutch slips under load and engine continues to run at high speed, excessive wear of clutch shoes is indicated.

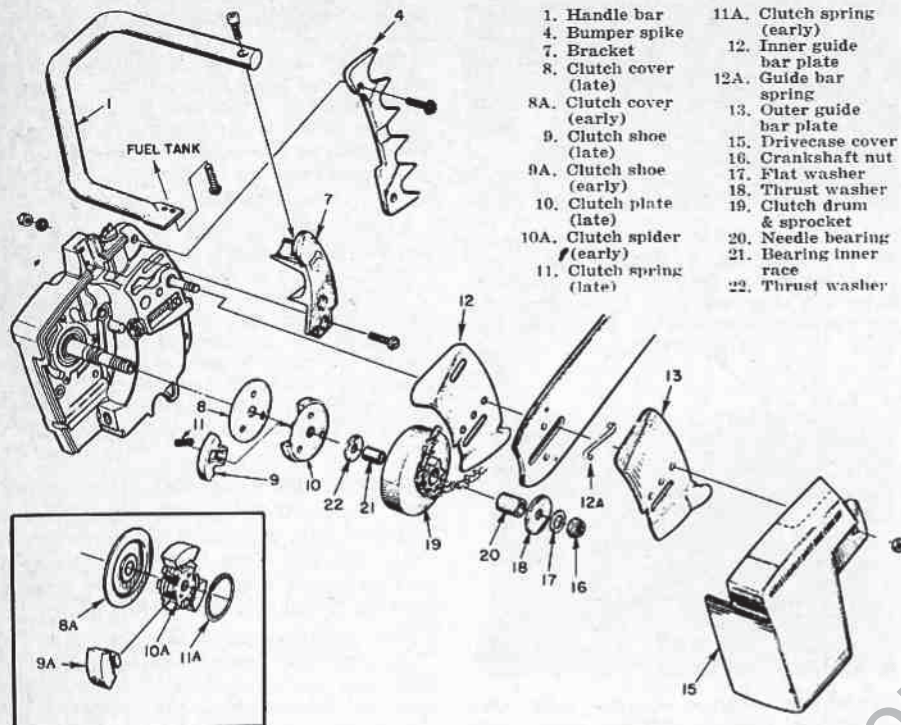

Fig. HL40—Exploded view of typical direct drive clutch assembly; refer to Fig. HL41A for gear drive models. Late type clutch assembly (items 8, 9, 10 & 11) is interchangeable as a unit with early production clutch shown in inset at lower left corner.

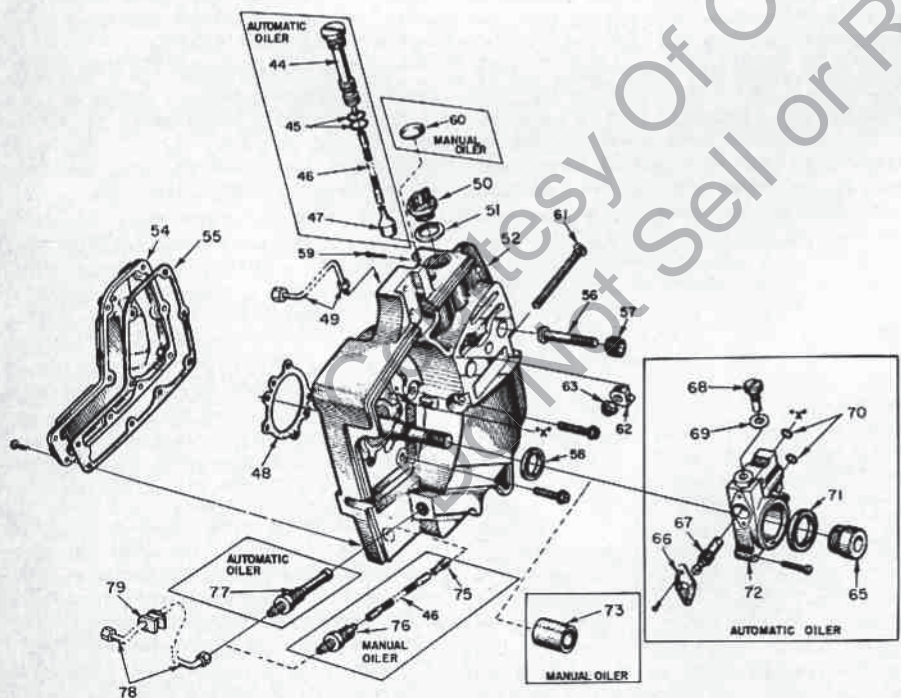

Fig. HL40A—Exploded view showing drive case with automatic chain oiler pump, oil pickups and late type removable oil reservoir cover (54). On all models except XL-12, XL-15 and Super XL-12, guide bar studs (56) are retained in drivecase by threaded inserts (57). Spacer sleeve (73) is used on model Super XL which is not equipped with automatic oiler pump.

- | | | | |
|----------------------|-------------------------|------------------------|----------------------------|
| 44. Oil line tube | 52. Drivecase | 61. Bar adjusting bolt | 70. "O" rings |
| 45. "O" rings | 54. Oil reservoir cover | 62. Bar adjusting pin | 71. Felt seal |
| 46. Flexible line | 55. Cover gasket | 63. Lock nut | 72. Pump body |
| 47. Oil filter | 56. Guide bar studs | 65. Worm gear | 73. Spacer sleeve |
| 48. Crankcase gasket | 57. Threaded inserts | 66. Flange | 75. Oil filter |
| 49. Oil line | 58. Crankshaft seal | 67. Plunger | 76. Connector |
| 50. Oil filler cap | 59. Cotter pin | 68. Cam screw | 77. Oil filter & connector |
| 51. Gasket | 60. Expansion plug | 69. Gasket | 78. Oil line |
| | | | 79. Grommet |

- | | |
|----------------------------|----------------------------|
| 1. Handle bar | 11A. Clutch spring (early) |
| 4. Bumper spike | 12. Inner guide bar plate |
| 7. Bracket | 12A. Guide bar spring |
| 8. Clutch cover (late) | 13. Outer guide bar plate |
| 8A. Clutch cover (early) | 15. Drivecase cover |
| 9. Clutch shoe (late) | 16. Crankshaft nut |
| 9A. Clutch shoe (early) | 17. Flat washer |
| 10. Clutch plate (late) | 18. Thrust washer |
| 10A. Clutch spider (early) | 19. Clutch drum & sprocket |
| 11. Clutch spring (late) | 20. Needle bearing |
| | 21. Bearing inner race |
| | 22. Thrust washer |

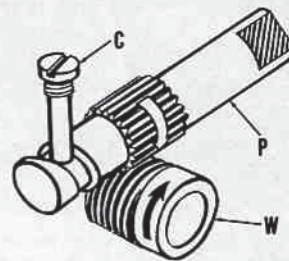

Fig. HL40B—Automatic oil pump worm gear (W) driven by crankshaft turns plunger (P) at 1/20 engine speed. As plunger turns, cam on end of plunger engages cam screw (C) causing the plunger to go back and forth. Flat end of plunger acts as inlet and outlet valve.

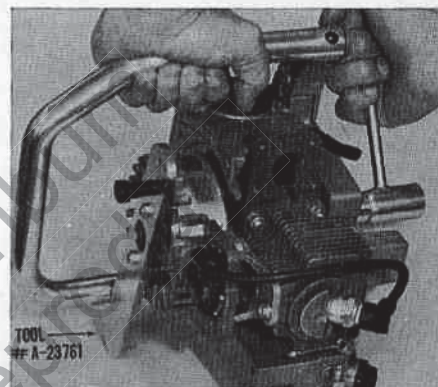

Fig. HL41 — Using Homelite tool No. A-23761 to keep crankshaft from turning while removing clutch retaining nut and clutch rotor. Homelite tool No. A-23696 is used to remove or install clutch rotor.

On early production model XL-12, clutch drum was equipped with an Oilite bushing. All later clutch drums, including service clutch drum for early XL-12, are fitted with caged needle roller bearings. When renewing early bushing type clutch drum, a new needle bearing inner race must also be installed.

Renew needle roller bearing inner race if wear marks are visible. Renew bearing in clutch drum if any roller has flat spot or is damaged, or if worn to extent that two rollers can be separated the width equal to thickness of one roller. Using installer plug, press against lettered side of needle bearing cage when installing bearing.

Refer to Fig. HL41B for assembly of late type clutch.

TRANSMISSION. Gear drive models are equipped with a planetary gear drive as shown in exploded view in Fig. HL41A.

To disassemble gear drive unit, drain oil from housing and remove screws (42); then, pull unit from housing (24). Hold drum (45) from turning by hand or in a three-jaw chuck and turn sun gear (31) in a clockwise direction with Homelite tool No. A-23696. Insert two 1/4 x 2 inch dowel pins in carrier (33), hold chain sprocket in sprocket locking fixture (Homelite tool No. A-23792) and turn planet carrier in a counter-clockwise direction with pry-bar against the dowel pins.

Planet gears (35) and shafts (36) can be removed from carrier after removing snap rings (34).

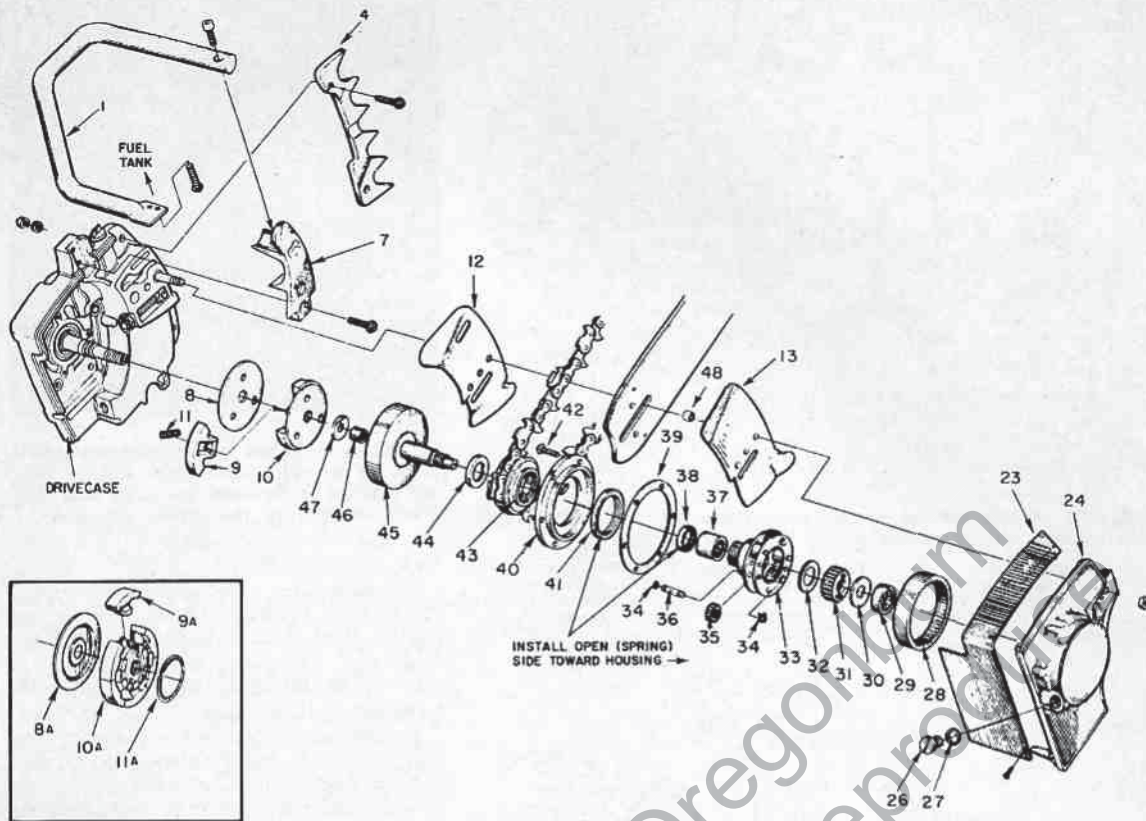

1. Handle bar
4. Bumper spike
7. Bracket
8. Clutch cover (late)
- 8A. Clutch cover (early)
9. Clutch shoe (late)
- 9A. Clutch shoe (early)
10. Clutch plate (late)
- 10A. Clutch spider (early)
11. Clutch spring (late)
- 11A. Clutch spring (early)
12. Inner guide bar plate
13. Outer guide bar plate
23. Chain guard
24. Gear housing
26. Filler cap
27. Gasket
28. Ring gear
29. Ball bearing
30. Thrust washer
31. Sun gear
32. Thrust washer
33. Planetary carrier
34. Snap rings
35. Planet gears & bearings
36. Gear shaft
37. Needle bearing
38. Oil seal
39. Gasket
40. Housing cover
41. Oil seal
42. Cover screws
43. Chain sprocket
44. Thrust washer
45. Clutch drum & shaft
46. Needle bearing
47. Phenolic thrust washer
48. Guide bar bushing

Fig. HL41A—Exploded view showing planetary gear drive transmission, clutch and drivecase. Late type clutch assembly (items 8, 9, 10 & 11) is interchangeable with early type clutch assembly (including clutch drum), remove bar stud retaining nuts and withdraw housing (24) and bar and chain from studs. Clutch plate (10), or spider (10A) is threaded to crankshaft.

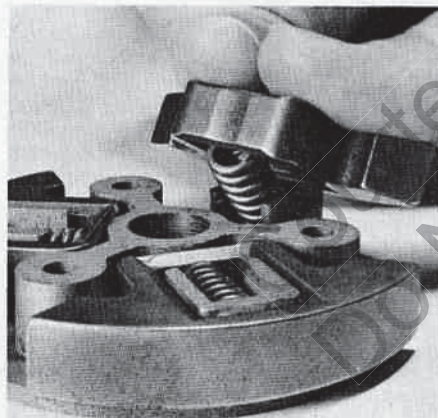

Fig. HL41B—View showing easy method for installing late type clutch shoes and springs on clutch plate.

1. Ground wire
2. Ignition switch
6. Blower (fan) housing
7. Bushing
8. Starter rope
9. Hand grip
10. Insert
11. Rewind spring
12. Rope pulley
13. Starter cup
14. Washer
15. Socket head screw
16. Flywheel nut
17. Lock washer
18. Flat washer
20. Pawl studs
21. Pawls
22. Washers
23. Pawl springs
24. Rotating screen
25. Flywheel

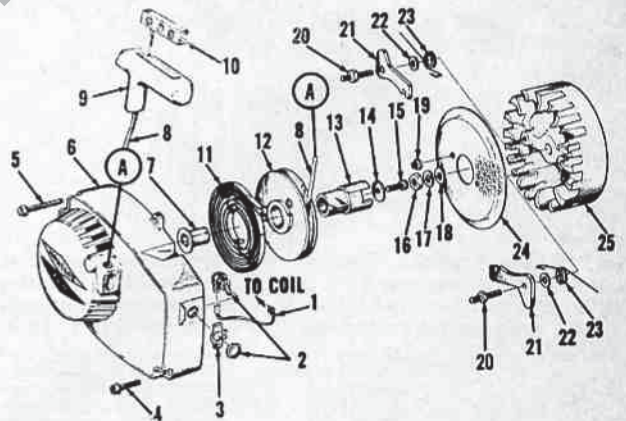

Fig. HL42 — Exploded view of early rewind starter components and related parts. Starter unit is mounted on shaft (starter post) which is an integral part of the blower housing. Refer to Fig. HL42A for late starter assembly.

Needle bearing (46) can be removed from blind hole in clutch drum with Snap-On puller A-78 or equivalent tool. Press on lettered end of bearing cage with Homelite tool No. 23726-A or other suitable bearing tool to install new bearing in drum. Needle bearing (37) and seal (38) in planet gear carrier (33) can be pressed out using Homelite tool No. 23725-A; press new bearing in from threaded side of carrier with short end of tool No. 23725-A and press new seal in with lip towards needle bearing with Homelite tool No. 23726-A.

To remove ball bearing (29) and ring gear (28) from housing (24), heat finned area of

housing until bearing can be removed by tapping housing against bench. Then, heat housing until ring gear can be removed. Always be sure to remove bearing first and install last with as little heat as possible.

Reassemble by reversing disassembly sequence using new gasket (39). Refill gear housing with SAE 90 gear oil.

AUTOMATIC CHAIN OILER PUMP. Refer to Fig. HL40A for exploded view of typical automatic oiler pump installation, and to Fig. HL40B for schematic view showing pump operation.

The automatic oiler pump is accessible

after removing the clutch assembly from crankshaft and disconnecting oil lines. Pump plunger (67) and body (72) are available as a complete assembly only which includes flange (66), cam screw (68), gasket (69), "O" rings (70), sealing felt (71) and flange retaining screws; however, all parts except plunger and body are available separately.

Inspect tip of cam screw (68) and cam groove on plunger (67) for wear and plunger bore in body and piston portion of plunger for scoring or wear. Renew pump assembly if body and/or piston is worn or damaged beyond further use.

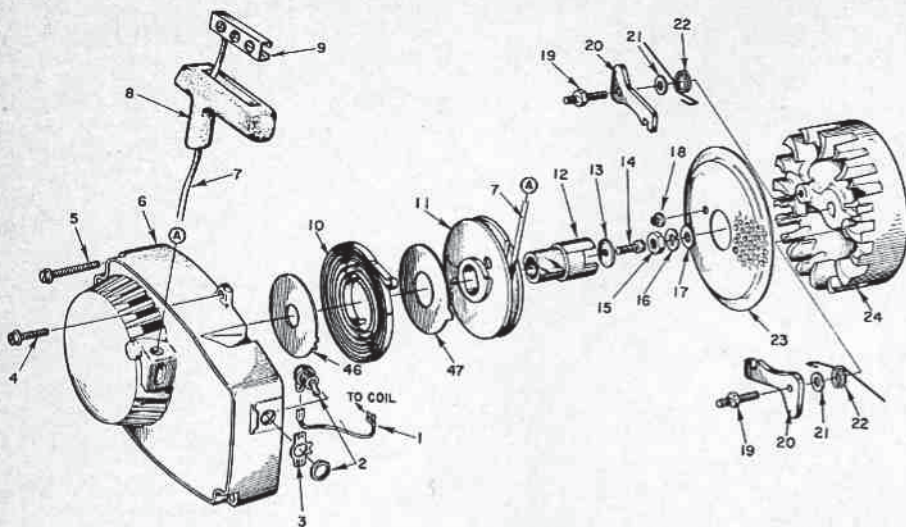

Fig. HL42A — Exploded view of late rewind starter and related parts. Plastic shields (46 and 47) keep sawdust out of rewind spring (10) and dampen noise.

- | | | | |
|-------------------------|-----------------------|-----------------|---------------------|
| 1. Ground wire | 11. Rope pulley | 16. Lock washer | 21. Washers |
| 2. Ignition switch | 12. Starter cup | 17. Flat washer | 22. Pawl springs |
| 6. Blower (fan) housing | 13. Washer | 18. Lock nut | 23. Rotating screen |
| 7. Starter rope | 14. Socket head screw | 19. Pawl studs | 24. Flywheel |
| 10. Rewind spring | 15. Flywheel nut | 20. Pawls | |

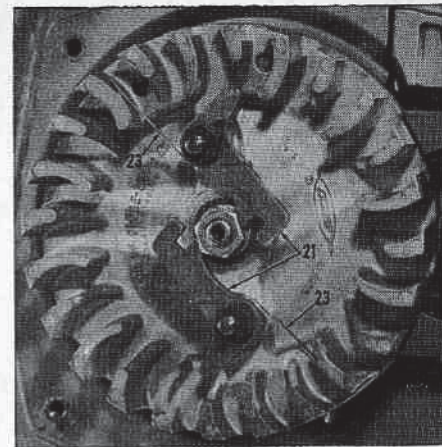

Fig. HL43 — When installing starter pawls (21), be sure that pawl return springs (22) are located in flywheel vanes so that they are parallel to the pawls as shown.

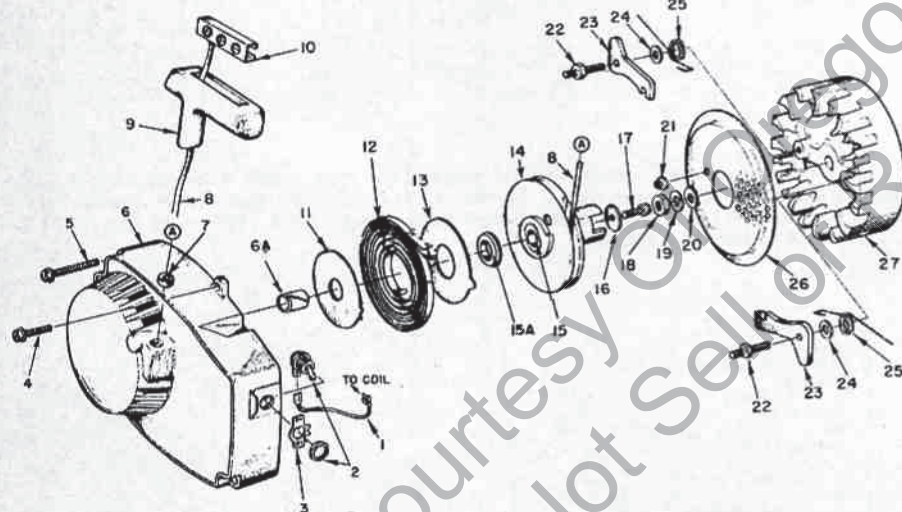

Fig. HL42B—Exploded view of latest production rewind starter assembly. Pulley (14) and integral starter cup (see item 12, Fig. HL42A), together with spring lock (15) and spring lock bushing (15A), can be used to renew early starter pulley (11—Fig. HL42A) and separate starter cup. Ignition cut-off switch and wiring are also shown.

- | | | | | |
|--------------------|-------------------------|--------------------------|---------------------------|----------------------|
| 1. Ground lead | 8. Starter rope | 13. Outer spring shield | 17. Hex head screw | 22. Pawl studs |
| 2. "ON-OFF" switch | 9. Starter handle | 14. Starter pulley | 18. Crankshaft nut | 23. Starter pawls |
| 3. Switch plate | 10. Insert | 15. Spring lock | 19. Lock washer | 24. Washers |
| 6. Fan housing | 11. Inner spring shield | 15A. Spring lock bushing | 20. Flat washer | 25. Pawl springs |
| 6A. Bushing | 12. Rewind spring | 16. Retaining washer | 21. Screen retaining nuts | 26. Air screen |
| 7. Rope bushing | | | | 27. Rotor (flywheel) |

REWIND STARTER. Although several design changes have been made, later production parts may be installed on earlier production starter and fan housing assemblies and service procedures are the same for all units.

Early production starter and fan housing assembly is shown in Fig. HL42. The starter post in fan housing (6) requires a flanged bushing (7) for starter pulley (12). The flanged bushing remains available for service, but if renewing fan housing, latest type fan housing (6—Fig. HL42B) with starter pulley bushing (6A), inner spring shield (11) and outer spring shield (13) are used.

Later production starter and fan housing are shown in exploded view in Fig. HL42A. The starter post in fan housing (6) fits directly into hub of starter pulley (11) and no bushing is used. Inner spring shield (46) and outer spring shield (47) have been added to dampen noise and keep sawdust out of rewind spring. Latest type fan housing (6—Fig. HL42B) and bushing (6A) are required to renew fan housing not using bushing.

Latest production starter and fan housing are shown in Fig. HL42B. In addition to starter pulley bushing (6A), starter pulley and starter cup are an integral unit (14) and a spring lock (15) and spring lock bushing (15A) have been added.

To renew early type starter pulley (12—Fig. HL42 or 11—Fig. HL42A) and/or starter cup (13—Fig. HL42 or 12—Fig. HL42A), use latest type pulley and integral starter cup (14—Fig. HL42B), spring lock (15) and spring lock bushing (15A).

To disassemble starter, pull starter rope fully out, hold starter pulley from turning, pull all slack in rope out inner side of fan housing and allow pulley to unwind slowly until spring tension is relieved. Remove the slotted hex head screw retaining pulley to post and remove starter pulley and cup with flat retaining washer. Remove the rewind spring and, if so equipped, the spring shields, from fan housing. Remove rope from pulley and handle.

Starter pulley post in fan housing is not renewable; a new fan housing must be installed if post is broken loose, or on mid-range production models without starter post bushing, if post is worn so that pulley is not held in proper position. Renew flanged bushing on early production models if bushing is worn excessively and fan housing is serviceable. Renew rope bushing if worn.

To reassemble, proceed as follows: Do not lubricate starter spring, but apply light oil sparingly to starter post, bushing (if used) and bore of starter pulley. Place outer shield (if used) in fan housing, then install rewind spring with loop in outer end over spring post in fan housing and install inner spring shield (if used). Attach starter cord to pulley, insert rope through rope bore or bushing in fan housing and attach handle and insert to outer end of rope. Wind rope onto starter pulley. Place pulley and starter cup (with spring lock and spring lock bushing if integral pulley and lock are used) on starter post and be sure spring lock or pulley is properly engaged with rewind spring. Install retaining washer and hex head screw and tighten screw to a torque of 50 inch-pounds. Pull rope out about two feet and hold pulley from turning. Locate notch in pulley at cord insert in housing and pull up loop of cord between notch and housing. Holding onto pulley, wind cord three more turns onto pulley by turning pulley, then let spring rewind pulley until handle is pulled against fan housing.

HOMELITE

A **Textron** DIVISION

PORT CHESTER, N.Y. U.S.A.

MODEL COVERAGE

| CHAIN SAW MODEL | DESIGN FEATURES |
|-----------------|-----------------|
| C-5 | A,F,K,M,Q |
| C-51 | A,F,K,M,Q |
| C-52 | A,F,K,M,Q |
| C-7 | B,F,K,M,Q |
| C-71 | B,F,K,M,Q |
| C-72 | B,F,K,M,Q |
| C-9 | C,G,K,M,Q |
| C-91 | C,J,K,M,Q |
| C-51G | A,F,K,N,P |
| C-71G | B,F,K,N,P |
| C-91G | C,J,K,N,P |
| XP-1000 | D,G,K,L,Q |
| XP-1020 | D,G,K,L,Q |
| XP-1020A | D,G,K,L,R |
| Super XP-1020 | D,G,K,L,Q |
| Super XP-1020A | D,G,K,L,R |
| XP-1100 | D,G,K,O,R |
| XP-1130A | D,G,K,O,R |
| Super XP-1130A | D,G,K,O,R |
| 2000 | E,H,K,L,R |
| 2000E | E,H,K,L,R |
| 2000P | E,H,K,L,R |
| Super 2000 | E,H,K,L,R |

DESIGN FEATURES CODE

- A—Displacement, 4.7 cu. in.; bore, 2 in.; stroke, 1½ in.
- B—Displacement, 4.9 cu. in.; bore, 2 in.; stroke, 1⅞ in.
- C—Displacement, 5.22 cu. in.; bore, 2⅛ in.; stroke, 1½ in.
- D—Displacement, 6.1 cu. in.; bore, 2⅝ in.; stroke, 1⅝ in.
- E—Displacement, 7.0 cu. in.; bore, 2 ¼ in.; stroke, 1¾ in.
- F—Flat reed type intake valve.
- G—Pyramid reed type intake valve, 4 reeds.
- H—Pyramid reed type intake valve, 6 reeds.
- J—Pyramid reed type intake valve, 4 reeds, prior to serial No. 1854403, flat reed type intake valve on all later production.
- K—Conventional flywheel type magneto.
- L—Direct drive.
- M—Direct drive, convertible to planetary gear drive.
- N—Planetary gear drive transmission.
- O—Three gear transmission with optional ratios of 2:1 and 3:1.
- P—Manual chain oiler only.
- Q—Manual chain oiler, automatic oiler kit available for models with drilled oil channel in drive case.
- R—Automatic and manual chain oiler.

Fig. HL50 — Exploded view of Tillotson Series HL carburetor typical of that used on all models except XP-1020, XP-1020 automatic, XP-1130 and late 2000. Refer to Figs. HL50A and HL-50B for carburetor used on these models.

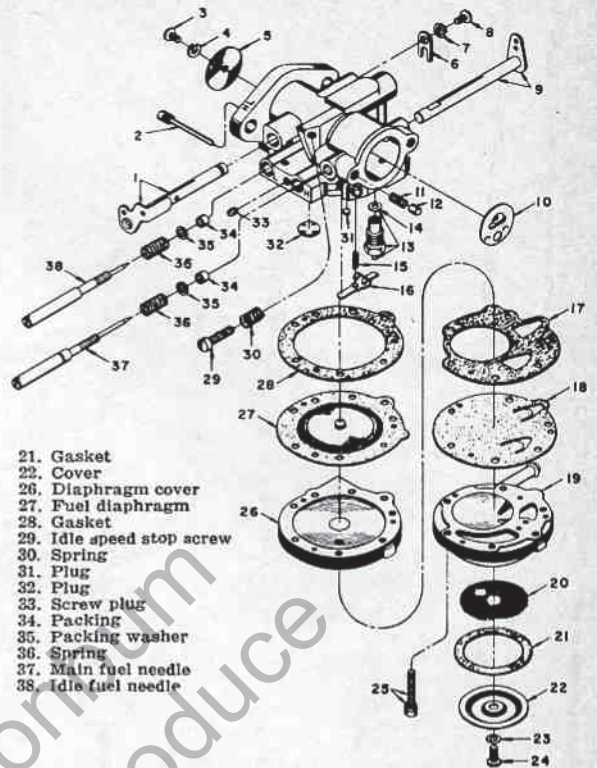

- 1. Throttle shaft
- 2. Diaphragm lever pin
- 5. Throttle disc
- 6. Retainer
- 9. Choke shaft
- 10. Choke disc
- 11. Spring
- 12. Choke detent
- 13. Fuel inlet valve
- 14. Sealing washer
- 15. Spring
- 16. Diaphragm lever
- 17. Gasket
- 18. Pump diaphragm
- 19. Pump body
- 20. Fuel screen
- 21. Gasket
- 22. Cover
- 26. Diaphragm cover
- 27. Fuel diaphragm
- 28. Gasket
- 29. Idle speed stop screw
- 30. Spring
- 31. Plug
- 32. Plug
- 33. Screw plug
- 34. Packing washer
- 35. Packing washer
- 36. Spring
- 37. Main fuel needle
- 38. Idle fuel needle

Fig. HL50A — Exploded view of Tillotson model HL-222A diaphragm carburetor with accelerator pump that is used on models XP-1020, XP-1020 Automatic and XP-1130. No idle speed stop screw is used as idle air is adjusted by screw (5—Fig. HL5)B) in intake manifold.

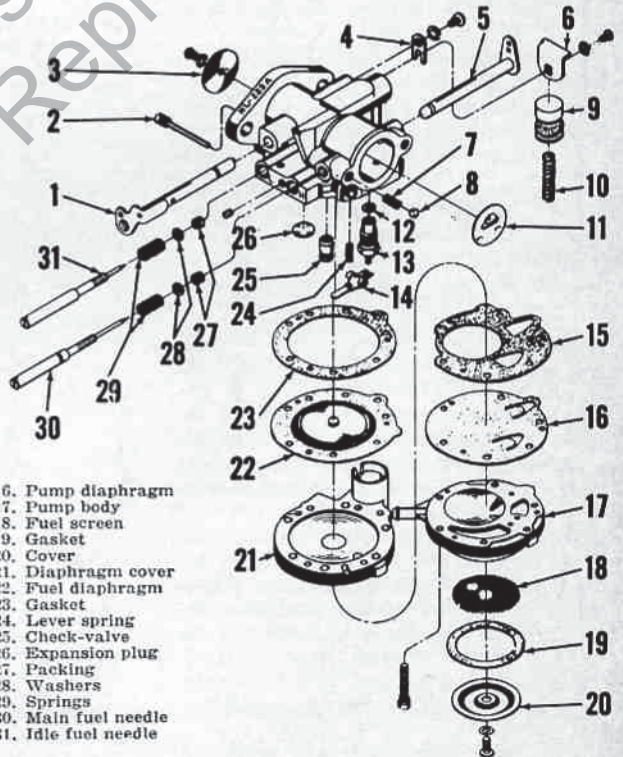

- 1. Throttle shaft
- 2. Diaphragm lever pin
- 3. Throttle disc
- 4. Retainer
- 5. Choke shaft
- 6. Accelerator cam
- 7. Detent spring
- 8. Choke detent ball
- 9. Accelerator piston
- 10. Piston return spring
- 11. Choke disc
- 12. Sealing washer
- 13. Fuel inlet valve & seat
- 14. Diaphragm lever
- 15. Gasket
- 16. Pump diaphragm
- 17. Pump body
- 18. Fuel screen
- 19. Gasket
- 20. Cover
- 21. Diaphragm cover
- 22. Fuel diaphragm
- 23. Gasket
- 24. Lever spring
- 25. Check-valve
- 26. Expansion plug
- 27. Packing
- 28. Washers
- 29. Springs
- 30. Main fuel needle
- 31. Idle fuel needle

MAINTENANCE

SPARK PLUG. Recommended Champion spark plug is as follows:

| Saw Model | Plug Type |
|------------------|-----------|
| All C-Series | J-6J |
| XP-1000, XP-1100 | UJ-11G |
| XP-1020 Series | CJ-6 |
| XP-1130 Series | CJ-6 |
| 2000 Series | UCJ-7G |

Set electrode gap to 0.025 on all models. For heavy duty service, use UJ-11G in place of J-6J; type J-6J may be substituted for UJ-11G, but will be more susceptible to electrode erosion. In extremely cold weather (below 0° F.), a UJ-12 plug may be used to prevent cold fouling.

CARBURETOR: (Except Models XP-1020, XP-1020 Automatic, XP-1130 and 2000 Series). Early model C-5 saws were equipped with a

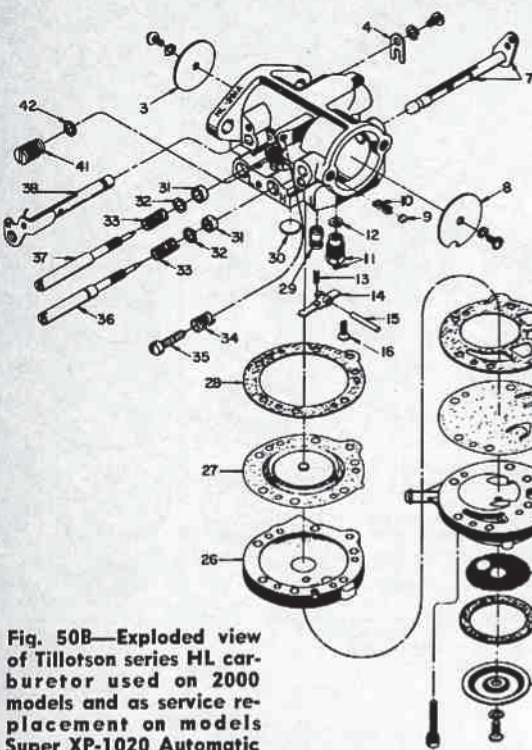

Fig. 50B—Exploded view of Tillotson series HL carburetor used on 2000 models and as service replacement on models Super XP-1020 Automatic and Super XP-1130. Note governor valve (41).

- 3. Throttle shutter
- 4. Throttle shaft clip
- 7. Choke shaft & lever
- 8. Choke shutter
- 9. Choke friction ball
- 10. Friction spring
- 11. Inlet needle & seat
- 12. Gasket
- 13. Diaphragm lever spring

- 14. Diaphragm lever
- 15. Lever fulcrum pin
- 16. Pin retaining screw
- 17. Diaphragm gasket
- 18. Fuel pump diaphragm
- 19. Fuel pump body
- 20. Fuel inlet screen
- 21. Pump strainer gasket
- 22. Strainer cover
- 26. Main diaphragm cover
- 27. Metering diaphragm
- 28. Diaphragm gasket
- 29. Main nozzle

Tillotson HL-141A carburetor. Late production C-5 saws and all other C models are equipped with a Tillotson HL-141B carburetor. The XP-1000 and XP-1100 models are equipped with a Tillotson HL-197A or HL-197B carburetor. Refer to Fig. HL50 for exploded view of carburetor. NOTE: If air filter cover gasket (5—Fig. HL51 or HL51A) is damaged when cover is removed to service carburetor or air filter element, install new gasket as follows: Carefully remove old gasket from air box and be sure that surface is free of all saw dust, oil, etc. Apply "3M" cement to new gasket, and carefully place gasket adhesive side down, on lip around carburetor chamber. Note: Latest air filter element has integral gasket: Remove old gasket from air box when installing late type element.

NOTE: Service carburetor will have idle speed adjusting screw (29—Fig. HL50) installed in carburetor body. When installing new service carburetor on models having idle speed adjusting screw installed in air box, remove the screw and spring from air box and plug the hole with a special screw (Homelite part No. 71505). Note: Installation of internal adjusting screw (29) and spring (30) in existing carburetor is also recommended.

When servicing carburetor, note that the main fuel adjustment needle is identified by a groove cut in the shank of the needle.

- 30. Expansion plug
- 31. Packing
- 32. Washer
- 33. Friction spring
- 34. Friction spring
- 35. Idle stop screw
- 36. Main fuel needle
- 37. Idle fuel needle
- 38. Throttle shaft & lever
- 41. Governor valve
- 42. Gasket

For initial carburetor adjustment, open both the idle and main fuel adjustment needles $\frac{1}{2}$ to $\frac{3}{4}$ -turn each. Back idle speed stop screw out away from stop on throttle shaft arm; then, turn screw back in until it contacts stop plus $\frac{3}{4}$ -turn additional.

With engine warm and running, set idle fuel adjustment needle so that engine idles smoothly. Set the idle speed stop screw so that engine idles just below clutch engagement speed. Check engine for proper

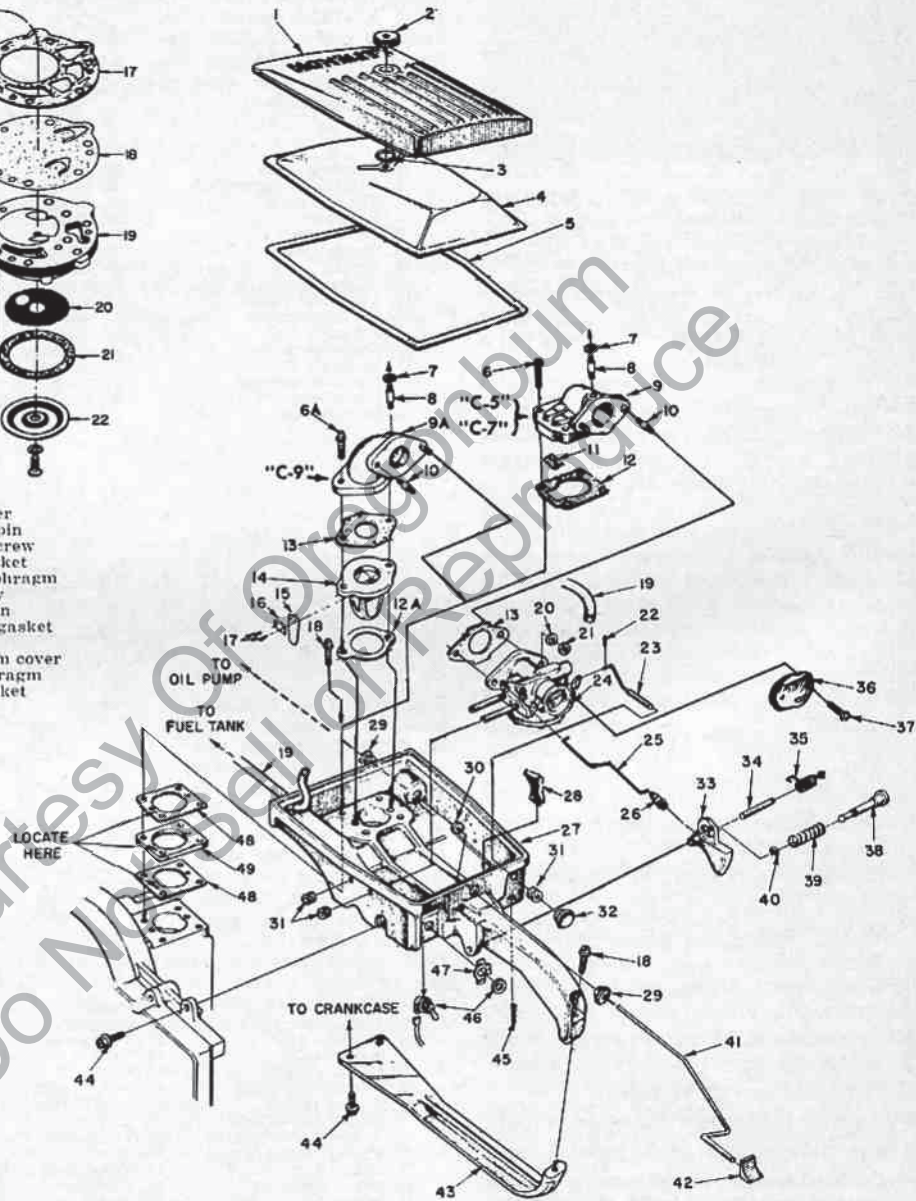
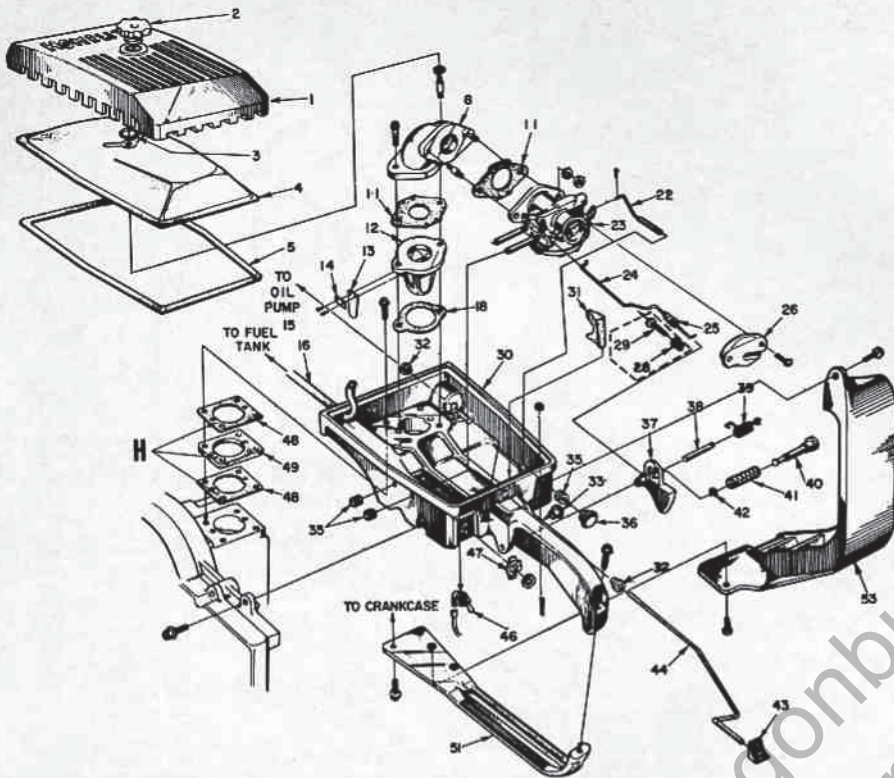

Fig. HL51—Exploded view of C-Series air box assembly (throttle handle) and related parts. Models C-5, C-51 and C-71 have integral elbow (9) and reed valve unit. Models C-9 and C-91 are equipped with pyramid type reed valve assembly (14, 15, 16 & 17). Air deflector (36) is used on late production Models C-7 and C-9 and can be installed on earlier production C-7 and C-9 units if clearance in air box is adequate and by installing new oil pump rod (41). Nylon pump rod bushing (29) and stop (28) fit only late production air box (throttle handle). Filler block (11) is used with C-51, C-71 and late production C-5 and C-7 elbow and reed valve assembly (9) only. Some models may have external idle speed adjusting screw (refer to 29—Fig. HL51A).

- | | | | |
|------------------------|---------------------|-------------------------------|---------------------|
| 1. Air filter cover | 13. Gasket | 26. Grommet | 35. Throttle spring |
| 4. Filter element | 14. Reed seat (C-9) | 27. Air box (throttle handle) | 36. Air deflector |
| 5. Gasket | 15. Valve reeds (4) | 28. Stop | 38. Throttle detent |
| 9. Elbow & Valve assy. | 16. Reed plates (4) | 29. Nylon bushing | 39. Spring |
| 9A. Elbow | 17. Screws (8) | 30. Felt washer | 41. Pump rod |
| 11. Filler block | 18. Fuel line | 31. Grommets | 46. Ignition switch |
| 12. Gasket (C-5 & C-7) | 19. Choke rod | 32. Choke button | 48. Gaskets |
| 12A. Gasket (C-9) | 24. Carburetor | 33. Throttle trigger | 49. Spacer |
| | 25. Throttle rod | | |



- | | |
|----------------------|------------------------|
| 1. Cover | 31. Stop |
| 2. Knob | 32. Grommet |
| 3. Retainer | 33. Bushing |
| 4. Filter | 35. Grommets |
| 5. Gasket | 36. Choke button |
| 8. Elbow | 37. Throttle trigger |
| 11. Gaskets | 38. Pivot pin |
| 12. Reed valve seat | 39. Return spring |
| 13. Reed valves | 40. Throttle latch pin |
| 14. Retainer | 41. Spring |
| 16. Fuel tube | 42. Snap ring |
| 18. Gasket | 43. Oiler button |
| 22. Choke rod | 44. Oiler rod |
| 23. Carburetor | 46. Ignition switch |
| 24. Throttle rod | 47. On-off plate |
| 25. Grommet | 48. Gaskets |
| 26. Air deflector | 49. Spacer |
| 28. Spring | 51. Brace |
| 29. Idle speed screw | 53. Muffler shield |
| 30. Air box | |

Fig. HL51A—Exploded view of air box assembly for models XP-1000 and XP-1100. External idle speed adjustment screw (29) and spring (28) should be removed on models so equipped, the hole in air box be plugged and an idle speed screw (29—Fig. HL50) and spring (30) be installed on carburetor; refer to text. Align holes (H) in gaskets (48) and spacer (49) with holes in air box and crankcase.

acceleration and open idle fuel adjustment needle slightly as needed for good acceleration. Adjust main fuel needle with engine loaded by cutting wood so that engine will run at highest speed obtainable without excessive smoke.

CARBURETOR (MODELS XP-1020, XP-1020 AUTOMATIC AND XP-1130). Refer to Fig. HL50A for exploded view of Tillotson model HL-222A diaphragm carburetor with accelerator pump that is used on models XP-1020, XP-1020 Automatic and XP-1130. No idle speed stop screw is used with this carburetor as idle air is adjusted by screw (5—Fig. HL51B) in intake manifold (elbow). The idle air screw (5) has left hand thread and is opened by turning it clockwise.

For initial carburetor adjustment, turn the fuel mixture adjustment needles clockwise and the air screw counter-clockwise until just seated, then open both fuel mixture needles one turn (counter-clockwise) and the air screw 3/8-turn (clockwise).

Make final adjustment with engine running and at operating temperature. Adjust the idle fuel (LO) needle to obtain fastest engine slow idle speed. Then, turn the idle air screw in (counter-clockwise) to decrease idle speed or out (clockwise) to increase idle speed to obtain an idle speed of 2500-2600 RPM. Readjust idle fuel (LO) needle if necessary.

NOTE: The clutch should engage only when engine speed exceeds 2600 RPM. If chain rotates when idle speed is below 2600 RPM, the clutch should be serviced.

Adjust the main fuel (HI) needle while cutting wood to obtain highest engine speed without excessive smoke. A slightly rich mixture insures against overheating of engine and provides better engine lubrication.

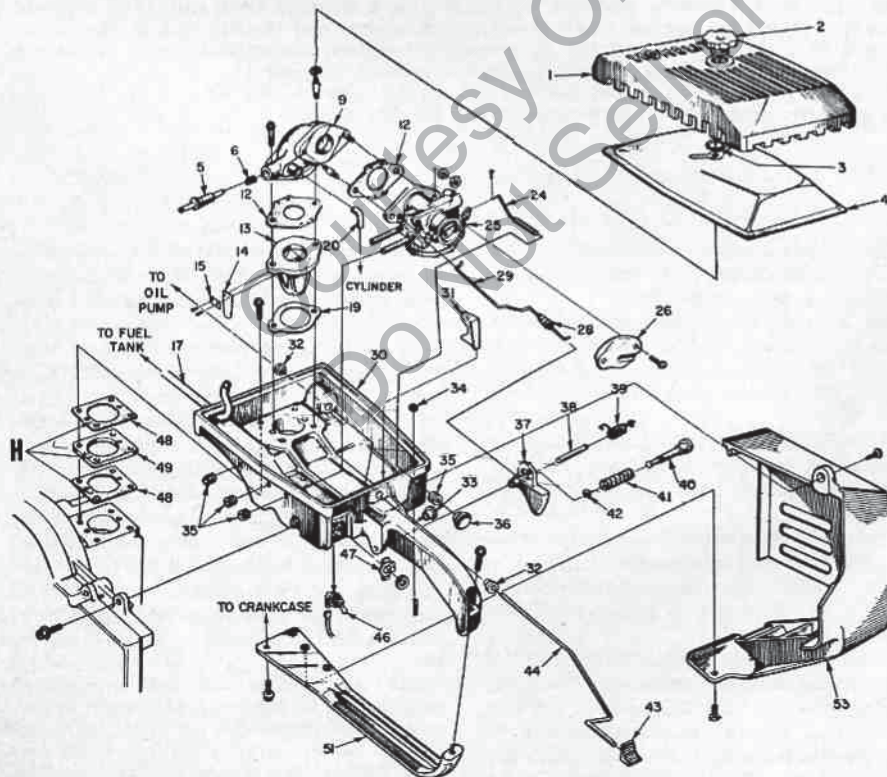

Fig. HL51B—Exploded view of air box assembly for models XP-1020, XP-1020 Automatic and XP-1130. Note idle air (speed) adjusting screw (5) in elbow (intake manifold) (9). Tube (20) is connected between intake manifold and cylinder transfer port. Align holes (H) in gaskets (48) and spacer (49) with holes in air box and crankcase as shown. Air filter element (4) has integral air box sealing gasket.

- | | |
|---------------------|------------------------|
| H. Holes | 31. Stop |
| 1. Cover | 32. Grommet |
| 2. Cover knob | 33. Bushing |
| 3. Retainer | 34. Felt |
| 4. Air filter | 35. Grommets |
| 5. Idle air screw | 36. Choke button |
| 6. Spring | 37. Throttle trigger |
| 9. Intake manifold | 38. Pivot pin |
| 12. Gaskets | 39. Return spring |
| 13. Reed valve seat | 40. Throttle latch pin |
| 14. Reed valves | 41. Spring |
| 15. Retainers | 42. Snap ring |
| 19. Gasket | 43. Oiler button |
| 20. Idle air tube | 44. Oiler rod |
| 24. Choke rod | 46. Ignition switch |
| 25. Carburetor | 47. On-off plate |
| 26. Air deflector | 48. Gaskets |
| 28. Grommet | 49. Spacer |
| 29. Throttle rod | 51. Brace |
| 30. Air box | 53. Muffler shield |

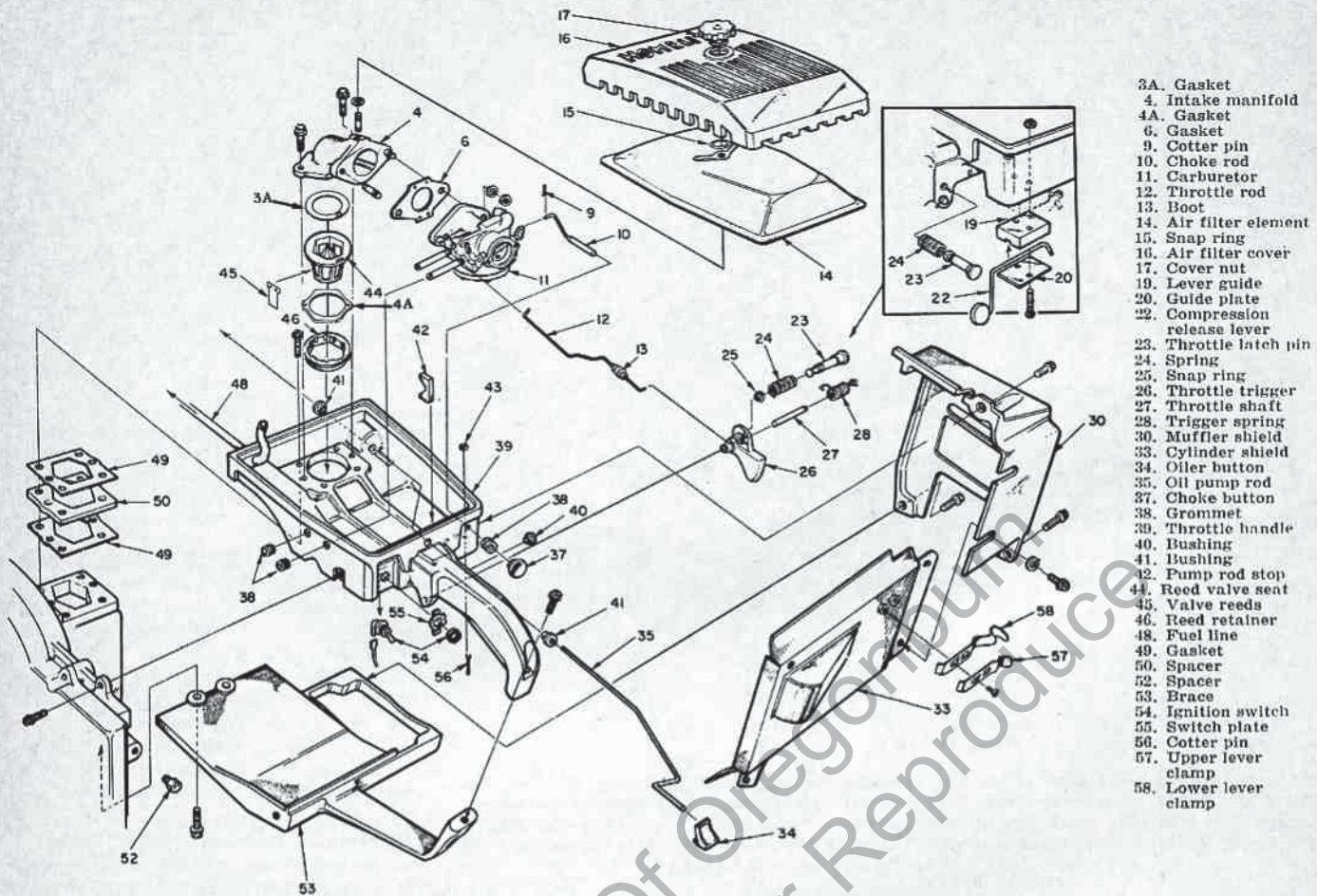

Fig. HL51C—Exploded view of model 2000 air box and throttle handle assembly. A Delrin plastic pyramid reed seat (44) with six reeds (45) is used; reeds are retained on pins moulded in seat by retainer (46). Compression release and throttle lock mechanism is shown in inset at upper right. Spring clamps (57 and 58), which are adjustable by loosening retaining screws and sliding in slotted holes, retain compression release lever in open and closed positions. Early models did not use gaskets (3A and 4A); do not install gaskets on these models unless a new intake manifold is also installed. On model Super 2000, intake reed on side of seat towards carburetor is shorter than the other five reeds, also, a carburetor support bracket is used.

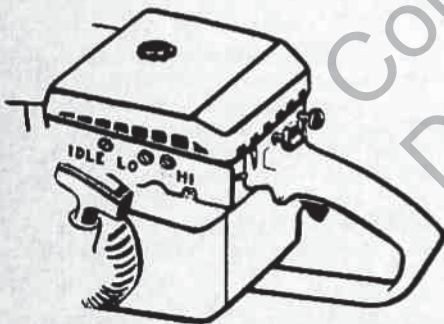

Fig. HL51E—View showing carburetor adjustment points for models XP-1020, XP-1020 Automatic and XP-1130. Refer to exploded view in Fig. HL51B for view showing idle adjusting screw (5), spring (6) and intake manifold (9).

CARBURETOR (2000 Model Series). Refer to Fig. HL50B for exploded view of Tillotson model HL261A carburetor used on some 2000 model series. Carburetor used on early production did not have the governor valve (41). Super 2000 is equipped with a model HL273A carburetor which is similar in construction to the model HL261A.

The governor valve opens at high speed to admit additional fuel, thus preventing leaning out and overspeeding.

Use Fig. HL50B as disassembly and re-assembly guide; refer to preceding paragraphs for carburetor adjustment information.

MAGNETO AND TIMING. All saws are equipped with a Phelon flywheel type magneto. Refer to Fig. HL52 for exploded view of magneto.

Timing is correct when stator plate (breaker box) is turned as far clockwise as possible before tightening mounting screws and breaker point gap is adjusted to specified value.

Condenser capacity should be 0.18-0.22 mfd. Adjust breaker point gap to 0.015. NOTE: On Models C-5, C-7 and C-9, Homelite recommends the use of a special spanner wrench (Homelite Part No. 23710) to hold the starter cup (15—Fig. HL64) while removing the flywheel nut to gain access to the magneto.

LUBRICATION. Engine is lubricated by mixing oil with fuel. Mix thoroughly in a

separate container ½-pint of Homelite motor oil or good grade SAE 30 motor oil with each gallon of regular gasoline (16:1 mixture).

Fill chain oil reservoir with Homelite Bar and Chain oil or a light oil (up to SAE 30 motor oil).

The planetary drive assembly or the clutch drum and sprocket assembly should be removed and the needle bearing in the clutch drum lubricated occasionally.

Check oil level in gear drive after each day of use. With saw setting on level surface, oil should be level with filler cap opening. Drain and flush gearcase with kerosene after each 100 hours of use. Refill with Homelite SAE 90 gear oil.

CARBON. Muffler and cylinder exhaust ports should be cleaned periodically to prevent loss of power due to carbon build up. Remove muffler and scrape free of carbon. With muffler removed, turn engine so that piston is at top dead center and carefully remove carbon from exhaust ports with a wooden scraper. Be careful not to damage edges of the exhaust ports or to scratch piston. Do not run engine with muffler removed.

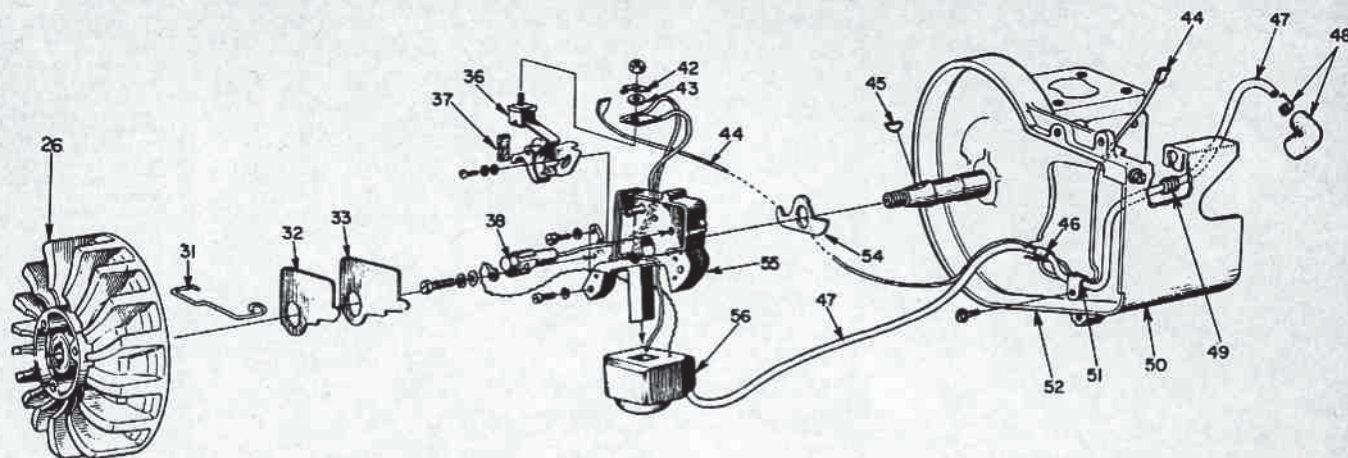

Fig. HL52—Exploded view of Phelon flywheel magneto typical of that used on all models in series. Rotor (flywheel) will differ in design according to type of starter used; refer to REWIND STARTER paragraph in repair section.

- | | | | | | |
|-----------------------|--------------------|---------------------|---------------------|---------------------|------------------------|
| 26. Rotor | 33. Gasket | 38. Condenser | 45. Rotor key | 49. Grommet | 52. Crankcase |
| 31. Retainer | 36. Breaker points | 42. Ground tab | 46. Sleeve | 50. Cylinder shield | 54. Seal |
| 32. Breaker box cover | 37. Cam wiper | 43. Terminal washer | 47. Spark plug wire | 51. Clamp | 55. Breaker box & core |
| | | 44. Switch lead | 48. Terminal | 56. Ignition coil | |

REPAIRS

TIGHTENING TORQUES. Recommended minimum tightening torques for C-series, XP-series and 2000-series saws are as follows: Note: All values are in inch-pounds; to find maximum tightening torque, add 20% to given values.

| | |
|---------------------------------------|-----|
| 4/40 Reed to adapter | 5 |
| 4/40 Flange bearing, oil pump | 5 |
| #6 Oil reservoir cover | 25 |
| Automatic oiler cam screw | 70 |
| 8/32 Oiler pump to drive-case | 40 |
| 8/32 Connecting rod | 55 |
| 8/32 Condenser screw | 15 |
| 10/32 Connecting rod | 70 |
| 10/32 Starter pulley | 50 |
| 10/32 Carburetor air deflector | 50 |
| 10/24 Stator to crankcase | 40 |
| 10/24 High tension lead clamp | 25 |
| 10/24 Cylinder shield | 50 |
| 12/24 Fuel tank | 80 |
| 12/24 Muffler cap | 50 |
| 12/24 Muffler to cylinder | 60 |
| 12/24 Pistol grip bracket | 80 |
| 12/24 Recoil starter assembly | 80 |
| 12/24 Air Shroud | 80 |
| 12/24 Carburetor chamber to crankcase | 80 |
| 12/24 Reed valve assembly | 80 |
| 12/24 Drivecase to crankcase | 80 |
| 12/24 Gearcase cover | 70 |
| 12/24 Chain guard | 80 |
| 12/24 Mounting bracket | 80 |
| 12/24 Idler gear post | 80 |
| 1/4-20 Main bearing retainer | 80 |
| 1/4-28 Check valve caps | 25 |
| 5/16-18 Handle bar | 180 |
| 3/8-24 Clutch nut | 250 |
| 7/16-24 Rotor (flywheel) nut | 250 |
| 1/2-20 Idler gear nut | 200 |
| 1/2-20 Sprocket nut | 250 |
| 14mm Spark plug | 250 |
| Clutch spider | 180 |

SPECIAL SERVICES TOOLS. The following special service tools are available for C-series, XP-series and 2000-series chain saws.

| Tool No. | Description and Model Usage | | |
|----------|--|---------|--|
| A-23809 | Plug connecting rod bearing, C-series. | A-23696 | Remover, spider, sun gear, all models. |
| 23874 | Plug, connecting rod bearing, XP-series. | 23678 | Tool, starter bearing, C-series, early XP. |
| 24206-1 | Plug, connecting rod bearing, 2000. | A-23679 | Remover, starter bearing, C-series, early XP |
| 22828 | Pliers, piston pin snap ring, all models. | A-23713 | Sprocket holder, C-series. |
| A-23950 | Remover, piston pin W/Spirol pin, XP-series. | 23725A | Plug, planetary bearing, C-series. |
| A-23951 | Remover, piston pin W/Spirol pin, C-series. | 23726A | Plug, planetary drum, C-series. |
| AA-22560 | Remover, rotor, C-series, early XP. | 23913 | Plug, ball bearing & seal, XP-1130 trans. |
| A-24028 | Remover, rotor, late XP-series, 2000. | 22750 | Sprocket locking tool, XP-1130. |
| A-23762 | Jackscrew, ball main bearing, all models. | 23228 | Plug, sprocket shaft bearing, XP-1130. |
| 23136 | Body for A-23762. | A-78 | Clutch drum bearing puller, C-series (Snap-On Tool). |
| 22820-2 | Bearing collar for A-23762. | | |
| 23670 | Aligning plate, crankshaft, C & XP-series. | | |
| 24207-1 | Aligning plate, crankshaft, 2000. | | |
| A-23858 | Fixture, drivecase, 2000. | | |
| 23373-4 | Bearing collar, 2000. | | |
| 23382 | Crankshaft spacer, 2000. | | |
| 24210-1 | Collar, 2000. | | |
| 23233-1 | Plug, crankcase seal, all models. | | |
| 23671 | Plug, drivecase seal, all models. | | |
| 23693 | Sleeve, drivecase seal, C & XP-series. | | |
| 23876 | Plug, drivecase bearing, C-series & XP-1020. | | |
| 23391-2 | Plug, drivecase bearing, C-series. | | |
| 23391-3 | Plug, drivecase bearing, XP-1130. | | |
| 23384 | Plug, drivecase seal, 2000. | | |
| 23390 | Sleeve, crankshaft assembling, 2000. | | |
| A-24138 | Reamer, compression release valve seat, 2000. | | |
| 23420 | Plug, clutch drum bearing, XP-1020 Automatic, XP-1130. | | |
| 23139 | Plug, clutch drum bearing, C-series, XP-1020. | | |
| A-23137 | Jackscrew, clutch, 2000. | | |

CONNECTING ROD. Connecting rod and piston assembly can be removed from crankpin after removing cylinder from crankcase. Be careful to remove all the loose needle rollers from crankcase.

The C model saws are equipped with 27 rollers whereas the XP models have 31 rollers and 2000 models have 26 rollers.

Renew connecting rod if bent or twisted, or if crankpin bearing surface is scored, burned or excessively worn. Latest connecting rods are 1/16-inch wider than early rods (at piston pin end). The caged needle roller piston pin bearing can be renewed by pressing old bearing out of rod and pressing new bearing in. On C series saws use Homelite special tool No. 23234 or equivalent to install early type needle bearing in early type rod, or Homelite tool A-23951 to install late type needle bearing. Press on lettered end of bearing cage only. On XP models, use Homelite tool 23874 to install needle bearing. On all 2000 models use Homelite Tool No. 24206-1.

Renew the crankpin needle rollers as a set if any roller has flat spots, or is scored or worn. New needle rollers are serviced in a strip; wrap the strip around crankpin. If reusing needle rollers, use beeswax or light

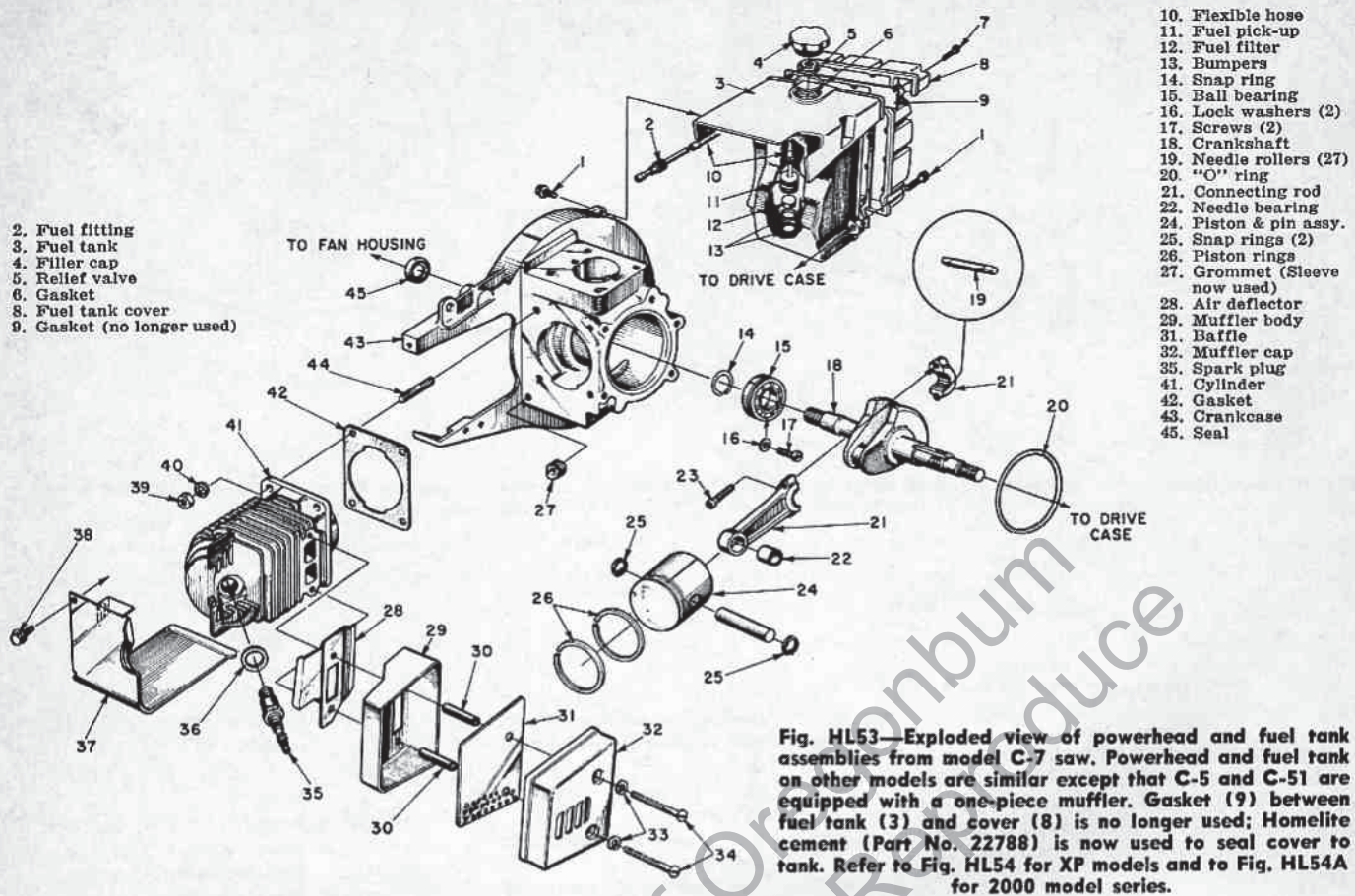

- 2. Fuel fitting
- 3. Fuel tank
- 4. Filler cap
- 5. Relief valve
- 6. Gasket
- 8. Fuel tank cover
- 9. Gasket (no longer used)

- 10. Flexible hose
- 11. Fuel pick-up
- 12. Fuel filter
- 13. Bumpers
- 14. Snap ring
- 15. Ball bearing
- 16. Lock washers (2)
- 17. Screws (2)
- 18. Crankshaft
- 19. Needle rollers (27)
- 20. "O" ring
- 21. Connecting rod
- 22. Needle bearing
- 24. Piston & pin assy.
- 25. Snap rings (2)
- 26. Piston rings
- 27. Grommet (Sleeve now used)
- 28. Air deflector
- 29. Muffler body
- 31. Baffle
- 32. Muffler cap
- 35. Spark plug
- 41. Cylinder
- 42. Gasket
- 43. Crankcase
- 45. Seal

Fig. HL53—Exploded view of powerhead and fuel tank assemblies from model C-7 saw. Powerhead and fuel tank on other models are similar except that C-5 and C-51 are equipped with a one-piece muffler. Gasket (9) is no longer used; Homelite cement (Part No. 22788) is now used to seal cover to tank. Refer to Fig. HL54 for XP models and to Fig. HL54A for 2000 model series.

grease to stick rollers to rod and cap. Install piston and rod assembly with ring retaining pin in piston away from exhaust port side of cylinder. Be sure that match marks on rod and cap are aligned and secure rod to cap with new socket head screws.

PISTON, PIN AND RINGS. On model Super 2000, piston is fitted with a pinned head land type piston ring; on all other models, piston is fitted with two pinned compression rings. Renew piston if scored, cracked or excessively worn, or if ring side clearance in top ring groove exceeds 0.004.

On 2-ring pistons, recommended piston ring end gap is 0.070-0.080; maximum allow-

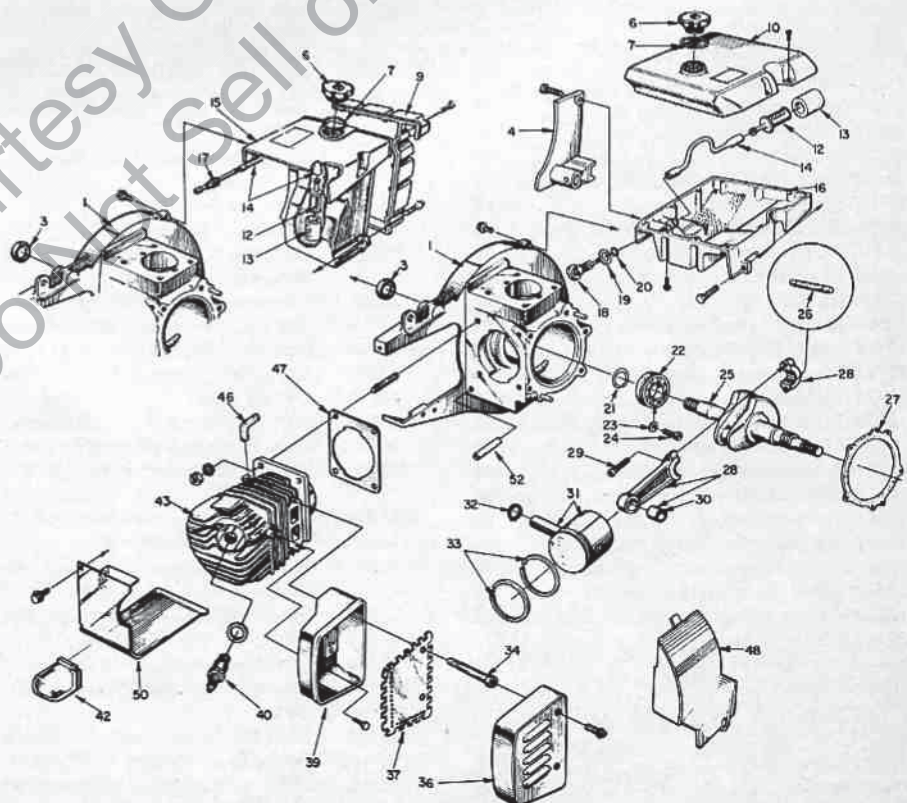

- 1. Crankcase
- 3. Crankshaft seal
- 4. Handle brace
- 6. Filler cap
- 7. "O" ring
- 9. Tank cover
- 10. Tank cover
- 12. Fuel pickup
- 13. Filter
- 14. Flex hose
- 15. Fuel tank
- 16. Fuel tank
- 17. Fitting
- 18. Fitting
- 19. Gasket
- 20. "O" ring
- 21. Snap ring
- 22. Ball bearing
- 23. Lock washers (2)
- 24. Screws (2)
- 25. Crankshaft
- 26. Needle rollers (31)
- 27. Gasket
- 28. Connecting rod
- 29. Screws
- 30. Needle bearing
- 31. Piston & pin
- 32. Snap ring
- 33. Piston rings
- 34. Muffler studs
- 36. Muffler cap
- 37. Baffle
- 39. Muffler body
- 40. Spark plug
- 42. Spark plug cap
- 43. Cylinder
- 46. Idle tube (see 20—Fig. HL51D)
- 47. Gasket
- 48. Heat exchanger (optional)
- 50. Cylinder shield

Fig. HL54—Exploded view showing model XP-1020 and model XP-1130 engine assembly. Model XP-1020 Automatic, model XP-1000 and model XP-1100 are similar. View shows fuel tank construction for both the direct and gear drive models.

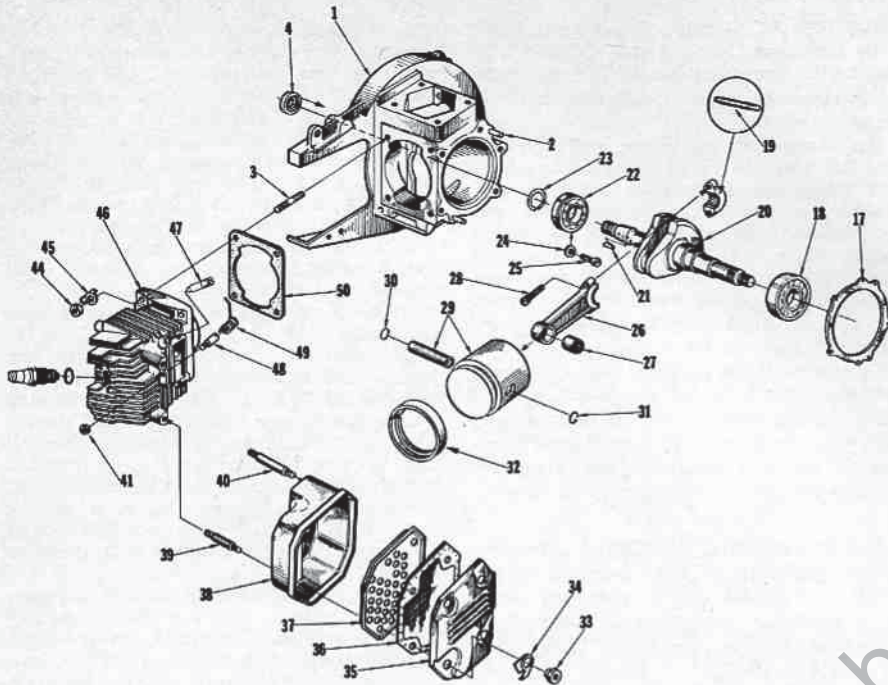

Fig. HL54A—Exploded view of Super 2000 power head. Other 2000 models are similar except that piston is fitted with two conventional 2-cycle type piston rings instead of the single Head Land type ring. Also, Rulon plastic pin retaining plugs were used on some models. Note compression release valve (47), release valve spring (49) and spring post (48).

- | | | | |
|--------------------|---------------------|--------------------|-------------------------------|
| 1. Crankcase | 21. Woodruff key | 28. Rod cap screws | 48. Muffer body |
| 2. Dowel pins | 22. Ball bearing | 30. Snap ring | 49. Self-locking nut |
| 3. Cylinder studs | 23. Snap ring | 31. Snap ring | 46. Cylinder |
| 4. Crankshaft seal | 24. Special washers | 32. Head land ring | 47. Compression release valve |
| 17. Gasket | 25. Bearing screws | 35. Muffer cover | 48. Spring post |
| 18. Ball bearing | 26. Connecting rod | 36. Spark arrester | 49. Spring |
| 19. Needle roller | 27. Needle bearing | 37. Muffer baffle | 50. Cylinder gasket |
| 20. Crankshaft | | | |

able ring end gap is 0.085. Desired ring side clearance in groove is 0.002-0.003. Ring end gap on head land ring should be 0.012-0.022; ring side clearance in groove should be 0.001-0.004.

Several different methods of retaining piston pin have been used; pin may be retained by two Waldes Truarc snap rings, by a non-removable Spirol pin at exhaust side and a Waldes Truarc snap ring at intake side, by two Rulon plastic plugs that snap into pin bore, or by a wire section snap ring at exhaust side and a Waldes Truarc snap ring at intake side of piston.

On all pistons with Truarc snap ring, remove snap ring from intake side using special pliers (Homelite tool No. 22828), then push pin out towards intake side. On models with snap ring at exhaust side, push pin out with a plain rod inserted through the snap ring. On models with Spirol pin, use slotted remover (Homelite tool No. A-23950). On models with Rulon plugs, pry plugs out, then remove piston pin.

When reassembling piston to connecting rod on models with Rulon plugs, install piston pin, then snap plugs into pin bore at each end of pin. Be sure pin and plugs are centered in piston.

When reassembling piston to connecting rod using snap rings or snap ring and Spirol pin, be sure closed end of pin is towards exhaust side of piston (away from piston ring locating pin or towards the Spirol or

wire section retaining ring. Be sure the Waldes Truarc snap ring, or rings are installed with sharp edge out and turn end gap of ring towards closed end of piston.

CRANKSHAFT, MAIN BEARINGS AND SEALS. Except on 2000 model series, the crankshaft is supported in a caged needle roller bearing at drivecase end of shaft and a ball bearing at flywheel end. End play of the crankshaft is controlled by the ball bearing which is retained on the crankshaft by a snap ring (14—Fig. HL53, or 21—Fig. HL54) and in the crankcase by two screws (17—Fig. HL53 or 24—Fig. HL54) and lock washers.

To remove crankshaft, first remove cylinder, piston and rod assembly and drivecase or transmission case, then proceed as follows: Remove and discard the two bearing retaining screws and special washers and press crankshaft and bearing from crankcase. If bearing is rough or excessively worn, remove snap ring and press crankshaft from bearing. Renew crankshaft if needle bearing surface at drive case end or crankpin bearing surface is burned, scored or excessively worn. Also, inspect keyways and threads for damage.

Install new seal with lip to inside of crankcase. Press bearing onto crankshaft and secure with snap ring. Apply heat to bearing seat in crankcase, taking care not to damage seal, until the crankshaft with main bearing can be pushed into the crankcase. Do not press bearing into crankcase.

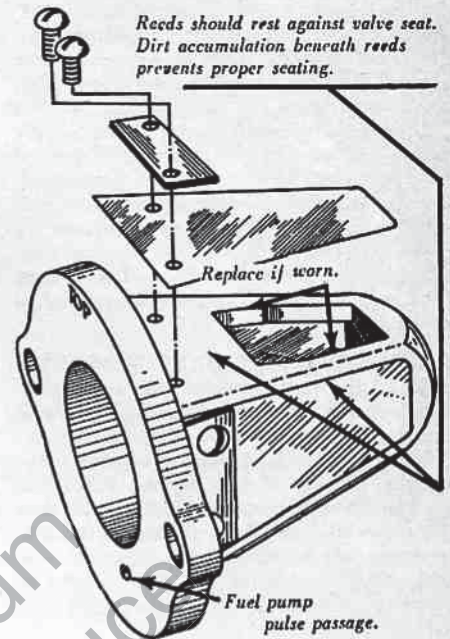

Fig. HL55—Pyramid type reed valve, showing proper installation for models with metal reed seat.

Install new bearing retaining screws and special washers.

Renew needle bearing (all models except 2000 series) in drive case, if necessary, by removing seal (18—Fig. HL56 or 4—Fig. HL58) and pressing bearings from casting. Press new bearing into case and install new seal with lip on inside. Place large "O" ring, or gasket on the drive case, place seal protector (or tape) over keyways, threads and shoulder; and install drive case on crankshaft and crankcase. Tighten the retaining screws alternately.

On 2000 model series, both ends of crankshaft are supported in ball bearings. Ball bearing (22—Fig. HL54A) at magneto side is retained in crankcase by two screws (25) and special washers (24). Ball bearing (18) at drive clutch end should be a press fit on crankshaft and a snug fit in drive case.

REED VALVE. (Except 2000 Series). The reed inlet valve on Models C-5, C-7, C-51 and C-71 is attached to the carburetor adapter elbow (9—Fig. HL51) and is serviced as a complete assembly only. A pyramid reed valve is used on other models. Refer to Fig. HL55 for service information on the pyramid reed valve assembly. When installing new reeds on pyramid seat, thoroughly clean all threads and apply Loctite to threads on screws before installing. Be sure reeds are centered on seats before tightening screws.

Be sure that pulse passage holes in gaskets (48) and spacer (49) are located as shown in Figs. HL51, HL51A and HL51B.

Reed lift distance on models C-5, C-7, C-51 and C-71 should be 0.172-0.177. The pyramid structure reeds on other models have no reed stops.

REED VALVE (2000 Model Series). A Delrin plastic pyramid reed seat (44—Fig. HL51C) with six inlet reeds is used on 2000 model series. The stainless steel reeds fit onto pins

moulded in plastic seat and are held in position by a retainer (46). On model Super 2000, the reed nearest carburetor is shorter than the remaining five reeds. Renew reed seat if worn or damaged and renew any broken or distorted reeds.

To assemble reeds to the Delrin plastic seat, stick the reeds to seat with a drop of oil under each reed. On model Super 2000, be sure the short reed is on the small reed opening in seat. On all models, be sure the reeds are properly located on the pins, then push retainer down over the reeds and seat, then install the seat, reeds and retainer as a unit.

COMPRESSION RELEASE VALVE. The 2000 models are equipped with a compression release valve (47—Fig. HL54A). Valve is operated by lever (22—Fig. HL51C).

Service of the compression release valve usually consists of cleaning the valve seat as the release port may gradually fill with carbon while engine is running with compression release valve open. A special service tool (Homelite tool No. A-24138) can be used to ream carbon from the valve seat and bore.

CLUTCH. All models are equipped with a dry shoe type clutch. Models C-5 and C-51 and early production model C-7 use three clutch shoes; all other models use six clutch shoes.

The clutch rotor (spider) on early production C-5 saws is keyed to the crankshaft, and has a spacer between the rotor and shoulder on crankshaft. Service rotor will be threaded; discard the keys but retain spacer when installing new type threaded rotor. Late production model C-5 saws and all other saws will have threaded rotor, but are not fitted with a spacer between rotor and shoulder on crankshaft.

To remove clutch on early model C-5 saw, pull the rotor from the crankshaft. On all other models hold crankshaft from turning and turn clutch rotor in a clockwise direction. If Homelite tools are not available, suitable spanner wrenches may be used.

TRANSMISSION (C SERIES). A planetary gear transmission is used on models C-52G, C-71G and C-91G and a planetary drive kit is available to convert C Series direct drive saws to gear drive. Refer to exploded view in Fig. HL57.

To disassemble gear drive unit, drain oil from housing and remove screws (5); then, pull unit from housing (16). Hold drum (2) from turning by hand or in a three-jaw chuck and turn sun gear (12) in a clockwise direction with Homelite tool No. A-23696 or suitable spanner wrench. Insert two ¼ x 2 inch dowel pins in carrier (11), hold chain sprocket from turning (use of Homelite sprocket locking fixture No. A-23713 is suggested) and turn planet carrier in a counter-clockwise direction with pry-bar against the dowel pins.

Needle bearing (1) can be removed from blind hole in clutch drum (2) with Snap-On puller A-78 or equivalent tool. Press on lettered end of bearing cage with Homelite tool No. 23726-A or other suitable bearing tool to install new bearing in drum. Needle bearing (10) and seal (9) in planet gear (11) can be pressed from gear with Homelite tool No. 23725-A; press new bearing in from threaded side of gear with short end of tool No. 23725-A and press new seal in with lip towards needle bearing with Homelite tool No. 23726-A.

To remove ball bearing (14) and ring gear (15) from housing (16), heat finned area of housing until bearing can be removed by tapping housing against bench. Then, heat housing until ring gear can be removed. Always be sure to remove bearing first and install last with as little heat as possible.

Reassemble by reversing disassembly sequence. Refill gear housing with SAE 90 gear oil.

TRANSMISSION (XP SERIES). Model XP-1100 and XP-1130 saws are equipped with a gear transmission as shown in Fig. HL58. Except for renewal of the crankshaft needle bearing, transmission can be serviced after cover (67) is removed.

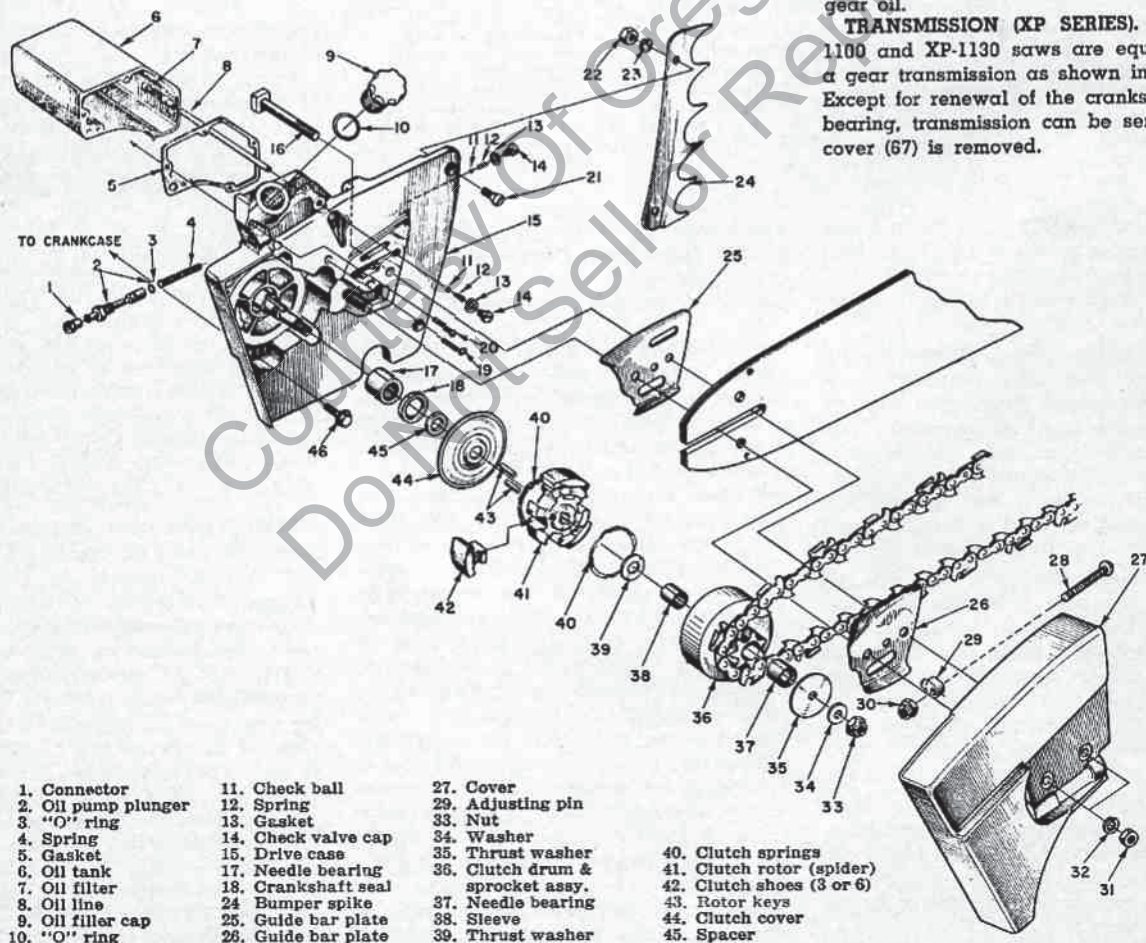
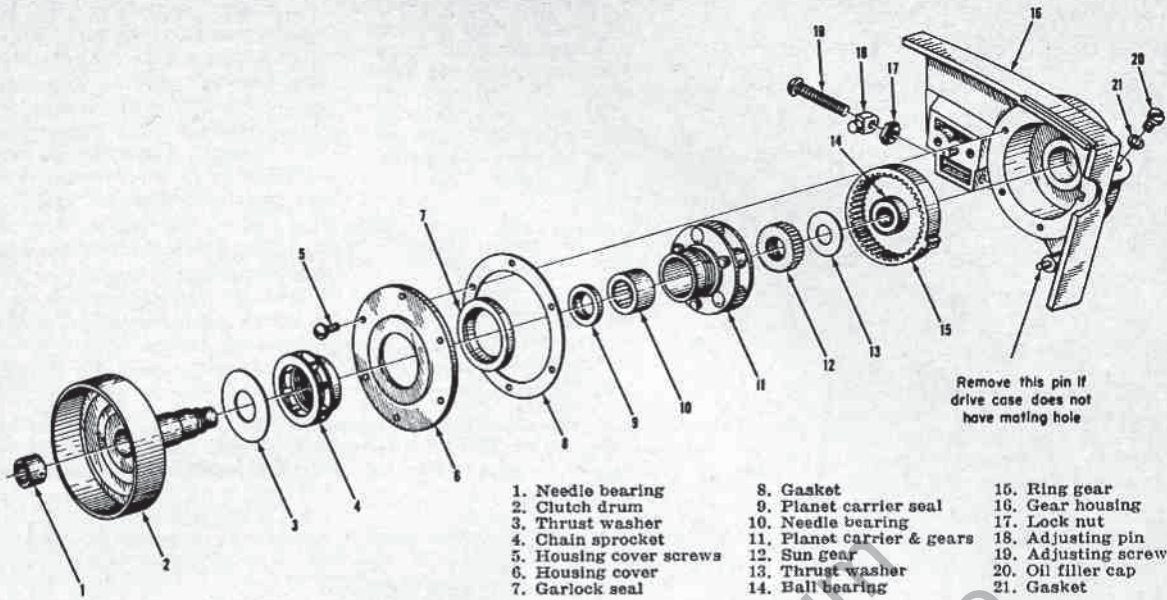

Fig. HL56 — Exploded view of direct drive clutch of Model C-5 and related parts. Same clutch rotor (spider) and shoe assembly 40, 41 & 42) are used with planetary gear drive shown in Fig. HL57. Rotor is threaded to crankshaft on C-7, C-9 and late production C-5 saws; keys (43) are not used on models with threaded spider. Spacer (45) is used on early production C-5 saws only. Six clutch shoes (42) are used on C-9, C-91 and late production model C-7; three shoes are used on C-5, C-51 and early production C-7. Six clutch shoes are required on all models with planetary gear drive.



Remove this pin if drive case does not have mating hole

- | | | |
|-------------------------|----------------------------|--------------------|
| 1. Needle bearing | 8. Gasket | 16. Ring gear |
| 2. Clutch drum | 9. Planet carrier seal | 17. Gear housing |
| 3. Thrust washer | 10. Needle bearing | 18. Lock nut |
| 4. Chain sprocket | 11. Planet carrier & gears | 19. Adjusting pin |
| 5. Housing cover screws | 12. Sun gear | 20. Oil filler cap |
| 6. Housing cover | 13. Thrust washer | 21. Gasket |
| 7. Garlock seal | 14. Ball bearing | |

Fig. HL57 — Exploded view of planetary drive unit that is used on C Series saws. When planetary drive is installed, a formica thrust washer should be installed between drum (2) and clutch rotor instead of steel thrust washer (39—Fig. HL56).

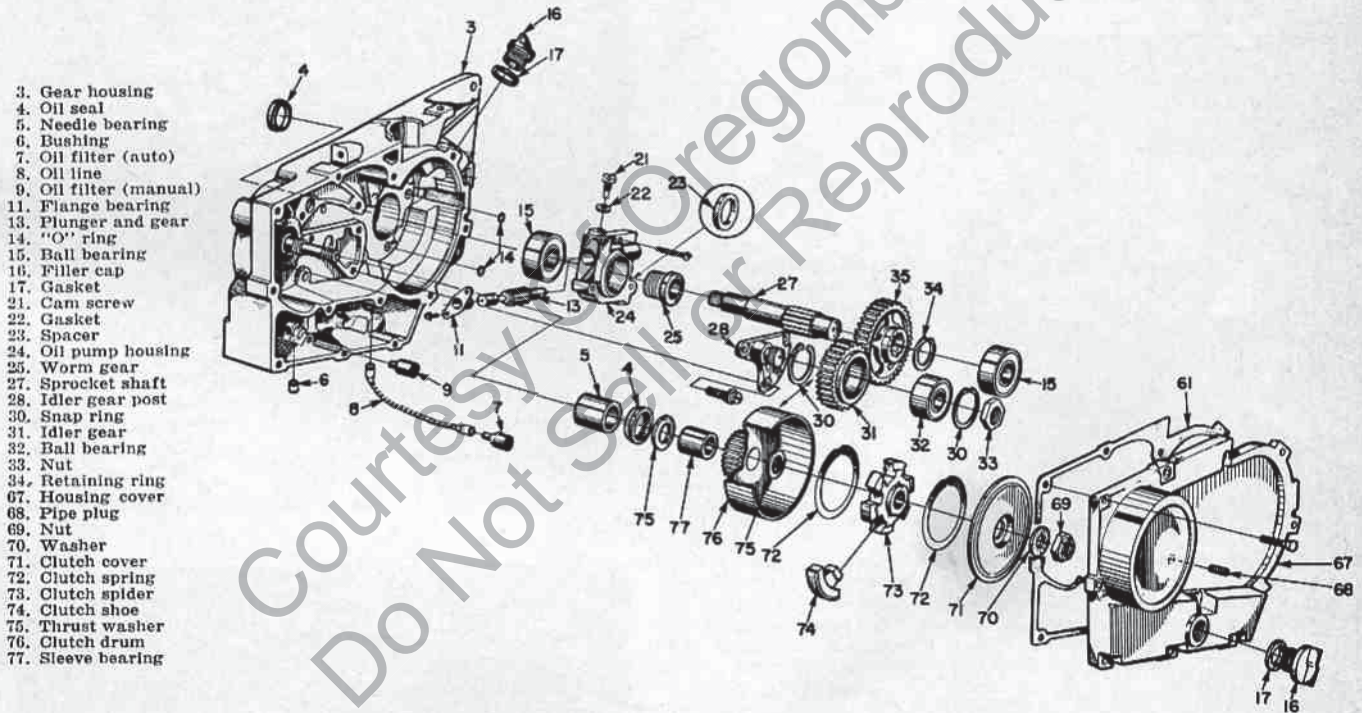

- 3. Gear housing
- 4. Oil seal
- 5. Needle bearing
- 6. Bushing
- 7. Oil filter (auto)
- 8. Oil line
- 9. Oil filter (manual)
- 11. Flange bearing
- 13. Plunger and gear
- 14. "O" ring
- 15. Ball bearing
- 16. Filler cap
- 17. Gasket
- 21. Cam screw
- 22. Gasket
- 23. Spacer
- 24. Oil pump housing
- 25. Worm gear
- 27. Sprocket shaft
- 28. Idler gear post
- 30. Snap ring
- 31. Idler gear
- 32. Ball bearing
- 33. Nut
- 34. Retaining ring
- 67. Housing cover
- 68. Pipe plug
- 69. Nut
- 70. Washer
- 71. Clutch cover
- 72. Clutch spring
- 73. Clutch spider
- 74. Clutch shoe
- 75. Thrust washer
- 76. Clutch drum
- 77. Sleeve bearing

Fig. HL58—Exploded view of gear case assembly used on models XP-1100 and XP-1130. Refer to Fig. HL58A for view showing opposite side of gear case and chain drive sprocket. A 1/8-inch thick spacer (23) is used with XP-1100 models having a 11/16-inch wide worm gear (25); do not use spacer if a 13/16-inch wide worm gear is used. Ratios of 2:1 and 3:1 can be obtained by changing gear (35) and repositioning idler gear assembly to accommodate the different gear teeth diameter. The 2:1 ratio gear has 42 teeth and the 3:1 ratio gear has 64 teeth.

NOTE: Effective with model XP-1130 serial No. 2188219, gear case is vented through drilled sprocket shaft instead of through hole in gear case. Also, the chain oiler reservoir is vented through the filler cap instead of through hole in reservoir. When installing the late type gear case (Homelite part No. A63398-B) in model XP-1100 or in model XP-1130 prior to serial No. 2188219, a new drilled sprocket shaft (part No. 59277-A) and vented chain oiler filler cap (part No. A63717) must also be installed. When in-

stalling drilled sprocket shaft in early type vented gear case, it is recommended that the transmission vent hole in gear case be plugged.

To service transmission, drain oil from chain oil tank and transmission case, then remove handlebar and cover (67). Tap cover lightly, if necessary, to loosen cover. Install a 1/4-inch lock pin through hole in bottom of blower housing to hold flywheel, then use a spanner wrench (Homelite A-23969) and turn clutch clockwise to remove it from

crankshaft. See Fig. HL59 and HL60. Thrust bearing (75) and clutch drum (76) can now be removed. Drum sleeve bearing (77—Fig. HL58) can be removed if necessary. Turn nut (33) clockwise to remove and lift idler gear assembly (31) off idler post (28). Bearing (32) can be removed from idler gear after removing snap rings (30). Remove retaining ring (34) and pull sprocket gear (35) from sprocket shaft (27). See Fig. HL61.

NOTE: Sprocket shaft gear can be removed without removing idler gear should it

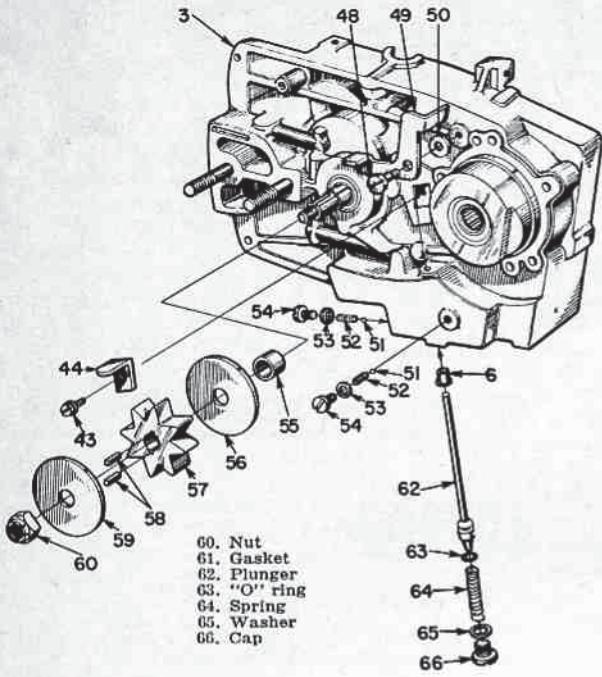

Fig. HL58A—View showing chain drive sprocket and manual oiler pump components removed from model XP-1100 and XP-1130 gear case. Refer to Fig. HL58 for exploded view of gear case assembly.

- 3. Gear case
- 6. Bushing
- 44. Bracket
- 49. Bellcrank
- 50. Thrust washer
- 51. Check ball
- 52. Spring
- 53. Gasket
- 54. Cap
- 55. Spacer
- 56. Washer, inner
- 57. Sprocket
- 58. Keys
- 59. Washer, outer

- 60. Nut
- 61. Gasket
- 62. Plunger
- 63. "O" ring
- 64. Spring
- 65. Washer
- 66. Cap

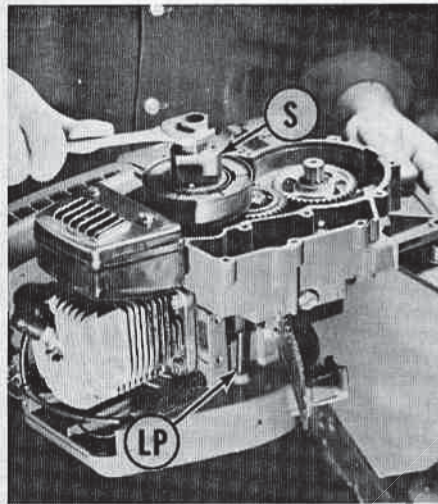

Fig. HL59—When removing clutch spider, use lock pin (LP) inserted as shown and turn clutch spider clockwise using a spanner wrench (S). Homelite number for spanner is A-23969.

be necessary for service only on the sprocket gear, sprocket shaft and bearings or the automatic chain oiler pump (OP) which is located behind the sprocket gear.

To remove the sprocket shaft, unbolt and remove the oil pump housing and discard the two "O" rings (14—Fig. HL58). Hold sprocket (57—Fig. HL 58A) from turning and remove nut (60), outer washer (59), sprocket and keys and inner washer (56), then push sprocket shaft from gearcase. Spacer (23—Fig. HL58) and worm gear (25) can now be removed from shaft.

NOTE: Spacer (23) is used with a short (11/16-inch long) worm gear (25) which was used in some saws. Do not use spacer in the saws which have a 13/16-inch long worm gear. For information on chain oiler pump, refer to Automatic Chain Oiler section.

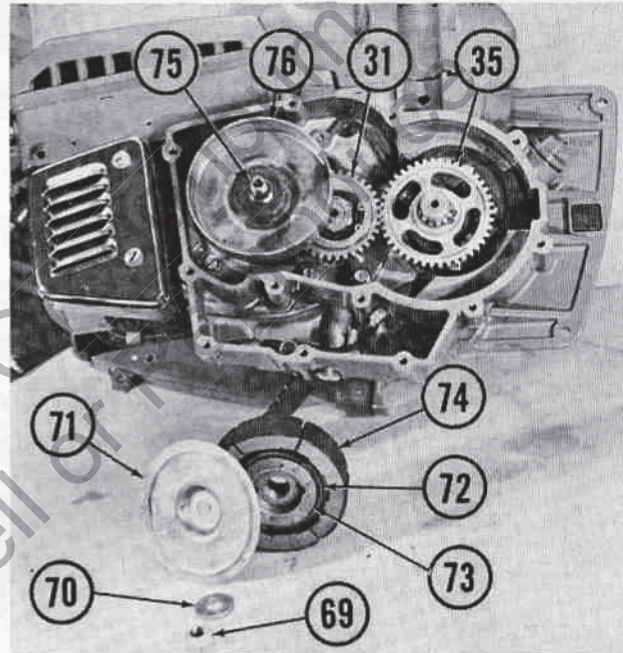

Fig. HL60—View of XP-1100 transmission with cover off and clutch assembly removed.

- 31. Idler gear
- 35. Sprocket gear
- 69. Nut
- 70. Washer
- 71. Clutch cover
- 72. Clutch spring
- 73. Clutch
- 74. Clutch shoe
- 75. Thrust washer
- 76. Clutch drum

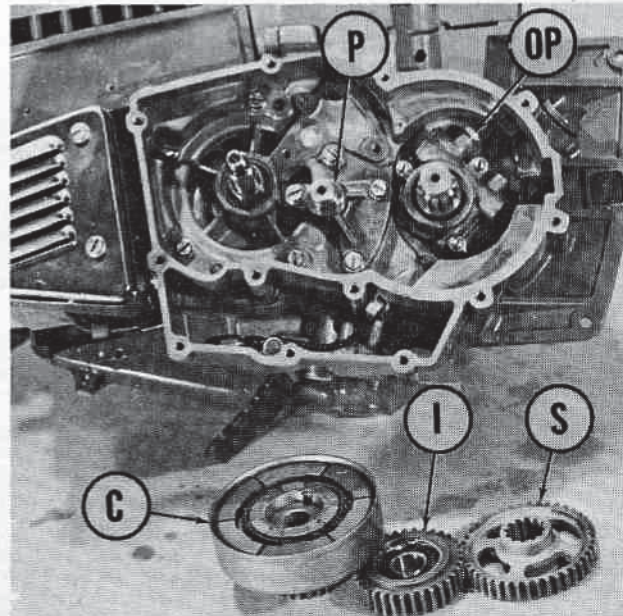

Fig. HL61—View of gearcase with clutch, idler gear and sprocket gear removed.

- C. Clutch assembly
- I. Idler gear assy.
- P. Idler gear post
- S. Sprocket gear
- OP. Oil pump (chain)

If sprocket shaft outer (pilot) bearing requires renewal, heat cover (67) until bearing will drop out. To remove sprocket shaft inner bearing, remove oil seal and press bearing out toward clutch side of gearcase using Homelite tool No. 23228, or equivalent.

If crankshaft needle (main) bearing (5—Fig. HL58) is to be renewed, remove gearcase and using Homelite tool No. 23931-3, press bearing out toward clutch side. When reinstalling bearing, install from engine side of gearcase and press only on lettered end of bearing. Use protector sleeve, Homelite No. 23963, over crankshaft when installing gearcase to engine.

Reassemble by reversing disassembly procedure. Use new oil seals and install with open side next to bearing. Use new "O" rings between gearcase and oil pump housing. Use Loctite on idler gearing retaining

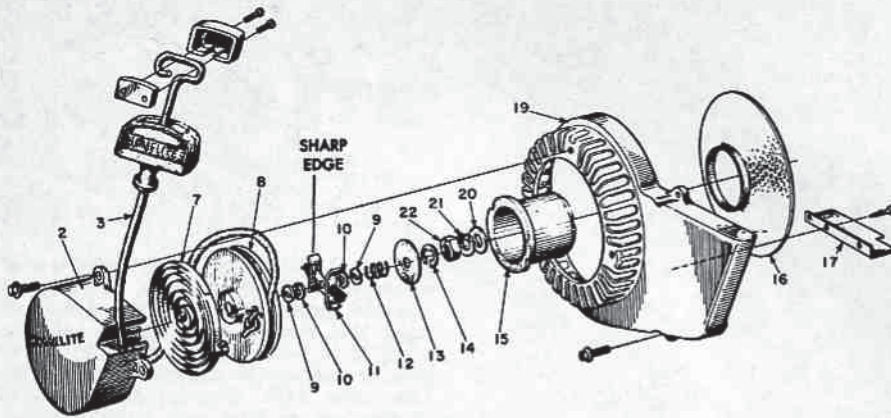

Fig. HL64—Exploded view of C Series Fairbanks-Morse starter. Friction shoe (11) components are not available separately; however, if unit has been disassembled, refer to Fig. HL64A for reassembly. Baffle (17) is integral with housing on late production units.

- | | | | |
|--------------------|-------------------|---------------------|------------------|
| 2. Starter housing | 9. Brake washer | 14. Snap ring | 19. Fan housing |
| 3. Starter rope | 10. Fiber washer | 15. Starter cup | 20. Flat washer |
| 7. Rewind spring | 11. Friction shoe | 16. Rotating screen | 21. Lock washer |
| 8. Starter pulley | 12. Spring | 17. Baffle | 22. Flywheel nut |
| | 13. Washer | | |

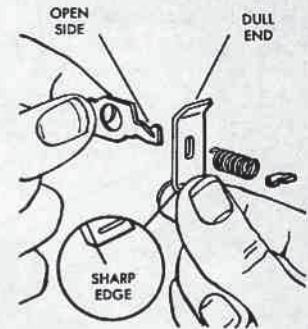

Fig. HL64A—Fairbanks-Morse friction shoe unit is serviced as complete assembly only. However, if unit has been disassembled, it must be reassembled as shown. Refer to Fig. HL64 for complete view of Fairbanks-Morse starter.

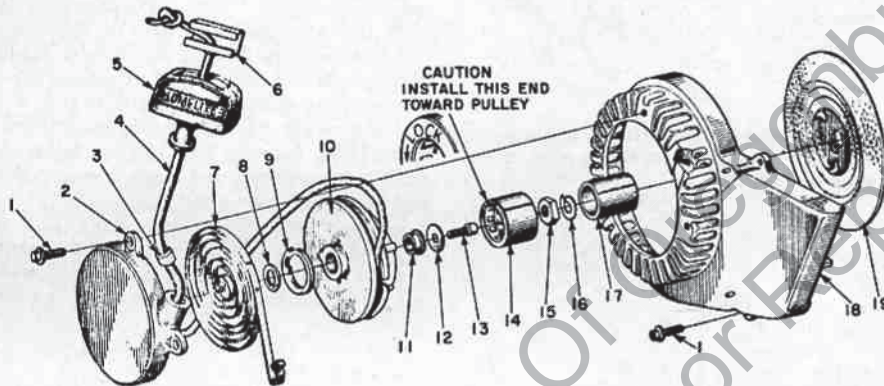

Fig. HL65—Exploded view of overrunning bearing starter used on models C-51, C-71, C-91, XP-1000 and XP-1100 and early models XP-1020 and XP-1130. Refer to Fig. HL64 for Fairbanks-Morse starter used on models C-5, C-7 and C-9 and to Fig. HL66 for ratchet starter used on model XP-1020 automatic and late model XP-1020 and XP-1130 saws.

- | | | | |
|------------------|-----------------------|-------------------------|-------------------------|
| 2. Starter cover | 8. Thrust washer | 12. Thrust washer | 16. Lock washer |
| 3. Rope bushing | 9. Rewind spring lock | 13. Socket head screw | 17. Inner race for (14) |
| 4. Starter rope | 10. Starter pulley | 14. Overrunning bearing | 18. Blower housing |
| 7. Rewind spring | 11. Pulley bushing | 15. Flywheel nut | 19. Rotary screen |

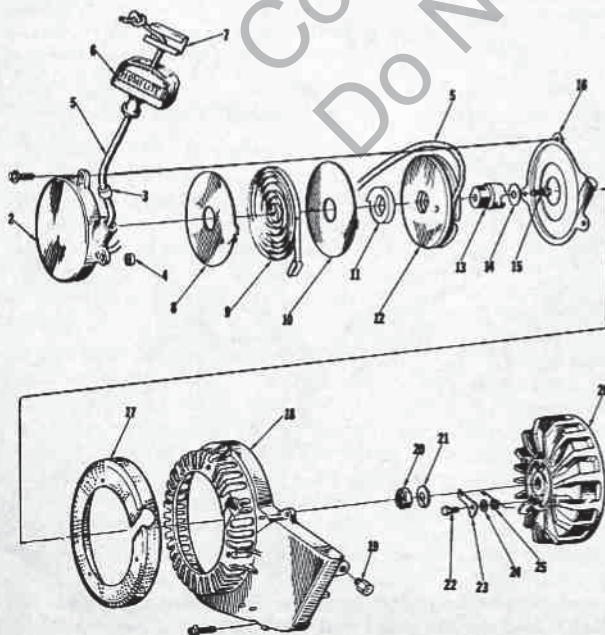

Fig. HL66 — Exploded view of rewind starter for 2000 model series. Starter for models XP-1020 Automatic and late models XP-1020 and XP-1130 is similar.

- | |
|-------------------------|
| 2. Starter cover |
| 3. Rope bushing |
| 4. Spring bushing |
| 5. Starter rope |
| 6. Hand grip |
| 7. Insert |
| 8. Inner spring shield |
| 9. Rewind spring |
| 10. Outer spring shield |
| 11. Spring lock |
| 12. Starter pulley |
| 13. Starter cup |
| 14. Retaining washer |
| 15. Self locking screw |
| 16. Sawdust shield |
| 17. Air screen |
| 18. Fan housing |
| 19. Spacer |
| 20. Crankshaft nut |
| 21. Flat washer |
| 22. Pawl stud |
| 23. Starter pawl |
| 24. Washer |
| 25. Pawl spring |
| 26. Rotor (flywheel) |

nut and tighten nut to 200 in.-lbs. torque. Tighten clutch spider and nut (69) to a minimum of 300 in.-lbs. torque and sprocket nut to 250 in.-lbs. torque.

REWIND STARTER. A Fairbanks-Morse rewind starter is used on models C-5, C-7 and C-9. Install friction shoes on brake lever as shown in Fig. HL64A if unit was disassembled. The friction shoe and lever unit is available for service as a complete assembly only. Refer to Fig. HL64 for complete starter exploded view.

Models C-51, C-71, C-91, XP-1000 and XP-1100 and early models XP-1020 and XP-1130 are equipped with an overrunning bearing type starter as shown in the exploded view in Fig. HL65. Be sure to note that bearing (14) must be installed with end lettered "LOCK" towards rope pulley (10).

All 2000 models, late model XP-1020 and XP-1130 saws (after serial No. 2359237) and model XP-1020 Automatic saws are equipped with a ratchet type starter as shown in Fig. HL66.

AUTOMATIC CHAIN OILER KIT. Refer to Fig. HL67 for exploded view of automatic oiler kit that can be installed on direct drive Series C and models XP-1000 and XP-1020 saws. If early C-5, C-7 or C-9 drive case does not have an "L" shaped oiler passage with a screw plug in the channel, a new type drive case must be installed to install the oiler kit. The manual chain oiler system is not affected by installation of the automatic oiler kit and can be used to supply extra chain lubricating oil in special cutting situations.

The drive pin (7) must extend 25/64 to 13/32-inch, and must engage the drive slot in clutch drum (1). Under normal conditions, use Homelite Bar and Chain oil or SAE 30 motor oil in reservoir. In cold weather, dilute oil with kerosene as necessary to keep it flowing through pump. Oil filter (24) can be cleaned after removing cover (26).

AUTOMATIC CHAIN OILER. Models XP-1100 and XP-1130 gear drive saws are equipped with an automatic chain oiler system and pump for this system is located inside the gear case; refer to Fig. HL61. Automatic chain oiler pump on direct drive XP-1020 and 2000 models is mounted on drivecase behind the chain sprocket and clutch assembly; refer to exploded view in Fig. HL68.

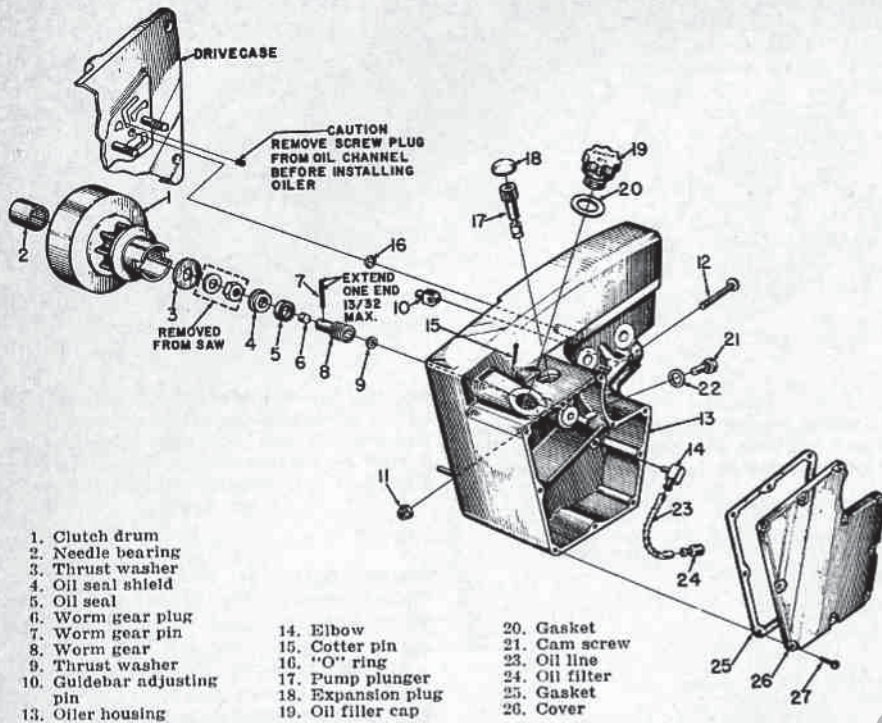

Fig. HL67—Exploded view of automatic chain oil kit available for Series C chain saws. If drive case does not have "L" shaped oiler passage as shown with a screw plug in the channel, a new drive case must be installed.

- | | | |
|----------------------------|--------------------|----------------|
| 1. Clutch drum | 14. Elbow | 20. Gasket |
| 2. Needle bearing | 15. Cotter pin | 21. Cam screw |
| 3. Thrust washer | 16. "O" ring | 23. Oil line |
| 4. Oil seal shield | 17. Pump plunger | 24. Oil filter |
| 5. Oil seal | 18. Expansion plug | 25. Gasket |
| 6. Worm gear plug | 19. Oil filler cap | 26. Cover |
| 7. Worm gear pin | | |
| 8. Worm gear | | |
| 9. Thrust washer | | |
| 10. Guidebar adjusting pin | | |
| 13. Oiler housing | | |

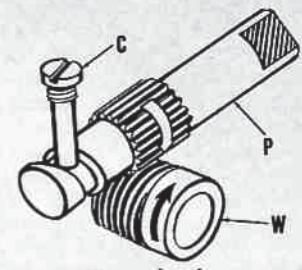

Fig. HL67A—View showing operation of automatic chain oiler pump. Worm (W) mounted on crankshaft or sprocket shaft turns the plunger (P). As the plunger turns, it is moved back and forth by the cam groove cut in plunger riding on the cam screw (C). Flats on piston end of plunger act as inlet and outlet valve as the plunger turns past inlet and outlet ports.

To service pump on gear drive models, drain chain oil tank and transmission case, then remove cover (67—Fig. HL50). Remove retaining ring (34) and pull gear (35) from sprocket shaft (27). Unbolt and remove pump body (24) from gearcase. Discard "O" rings (14) and use new during installation. Pump plunger (13) can be removed from body after removing the flanged bearing (11).

If necessary to remove worm (25), remove chain sprocket and spacer (55), push shaft from gearcase and remove spacer (23) and worm (25) from shaft.

NOTE: Spacer (23) is used only with a short (11/16-inch long) worm which was used in some saws. If saw is equipped with a long (13/16-inch long) worm, the spacer is not used.

To service pump on direct drive models, first remove the clutch assembly, clutch drum and sprocket and the drive worm (31—Fig. HL68). The pump can then be removed from crankcase cover (11).

Clean and inspect all parts and renew parts as necessary. Reassemble by reversing the disassembly procedure.

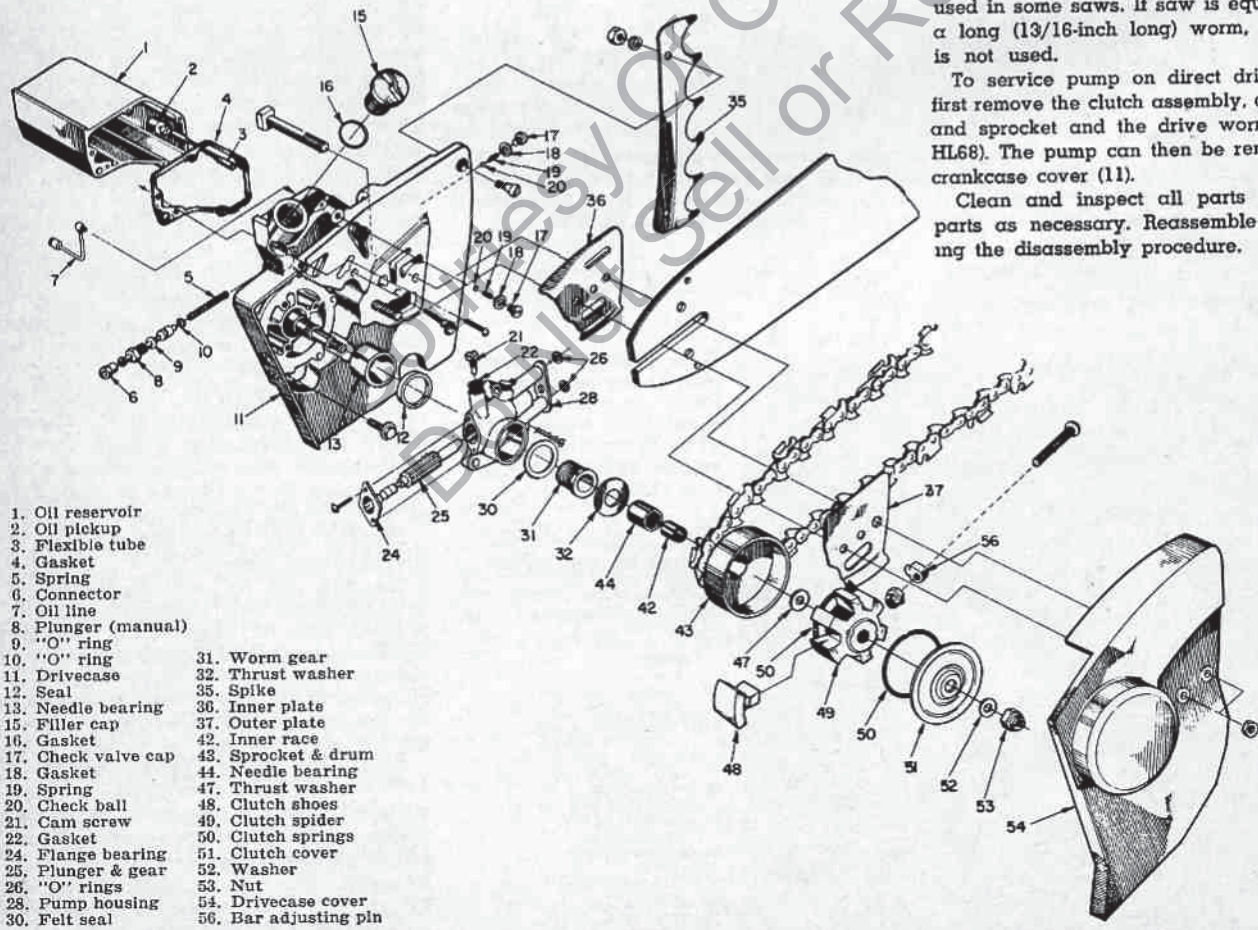

Fig. HL68—Exploded view of model XP-1020 Automatic chain oiler pump and related parts; 2000 models are similar except for ball bearing main instead of needle bearing. Refer to Fig. HL67A for view showing pump operation.

- | | |
|---------------------|-----------------------|
| 1. Oil reservoir | 31. Worm gear |
| 2. Oil pickup | 32. Thrust washer |
| 3. Flexible tube | 35. Spike |
| 4. Gasket | 36. Inner plate |
| 5. Spring | 37. Outer plate |
| 6. Connector | 42. Inner race |
| 7. Oil line | 43. Sprocket & drum |
| 8. Plunger (manual) | 44. Needle bearing |
| 9. "O" ring | 47. Thrust washer |
| 10. "O" ring | 48. Clutch shoes |
| 11. Drivecase | 49. Clutch spider |
| 12. Seal | 50. Clutch springs |
| 13. Needle bearing | 51. Clutch cover |
| 15. Filler cap | 52. Washer |
| 16. Gasket | 53. Nut |
| 17. Check valve cap | 54. Drivecase cover |
| 18. Gasket | 56. Bar adjusting pin |
| 19. Spring | |
| 20. Check ball | |
| 21. Cam screw | |
| 22. Gasket | |
| 24. Flange bearing | |
| 25. Plunger & gear | |
| 26. "O" rings | |
| 28. Pump housing | |
| 30. Felt seal | |

HOMELITE

A **Textron** DIVISION

PORT CHESTER, N.Y. U.S.A.

MODEL COVERAGE

| Chain Saw Model | Design Features |
|-----------------|------------------|
| XL-700 | A, C, D, H, J |
| XL-800 | B, C, D, H, K |
| XL-800AM | B, C, D, H, L |
| XL-850 | B, C, E, H, L |
| XL-870 | B, C, D, H, L |
| XL-875 | B, C, E, H, L |
| XL-900E | B, C, D, H, K |
| XL-900EAM | B, C, D, H, L |
| XL-901 | A, C, D, H, J |
| XL-903 | B, C, D, G, H, L |
| XL-903E | B, C, D, G, H, K |
| XL-903EAM | B, C, D, G, H, L |
| XL-904 | B, C, F, G, H, L |

DESIGN FEATURES CODE

- A—Displacement, 4.71 cu. in.; bore, 2 in.; stroke, 1½ in.
- B—Displacement, 5.01 cu. in.; bore, 2¼ in.; stroke, 1½ in.
- C—Pyramid reed type intake valves, 4 stainless steel reeds.
- D—Conventional type flywheel magneto.
- E—Solid state (transistorized breakerless) flywheel magneto.
- F—Capacitor discharge (CD) solid state magneto.
- G—Decompression valve (Simplex starting).
- H—Direct drive.
- J—Manual chain oiler only.
- K—Automatic chain oiler only.
- L—Automatic and manual chain oiler.

NOTE: Either a conventional flywheel type magneto (D) or a later type capacitor discharge magneto (F) can be installed as service replacement for earlier solid state (transistorized) magneto (E).

MAINTENANCE

SPARK PLUG. A Champion model CJ-6 spark plug is used for all models. For heavy duty operation, a Champion UJ11G gold-palladium tipped spark plug can be used, though it will be necessary to pull the plug wire further out of the retaining clip in air box. Set electrode gap to 0.025 on all models.

CARBURETOR. Except as alternate installation on model XL-901, Tillotson series HS diaphragm type carburetors with integral fuel pump are used. Refer to Fig. HL75 for exploded view of typical Tillotson series HS carburetor, and to Fig. HL 77 for exploded view of Walbro model SDC-9 carburetor used on some XL-901 units.

For initial adjustment on all models, back idle speed adjustment screw (see Fig. HL76) out until it clears throttle stop, then turn screw in until it contacts stop plus ¼-turn

3. Throttle disc
6. Fuel pump cover
7. Fuel pump gasket
8. Fuel pump diaphragm
9. Fuel screen
10. Throttle shaft retainer
11. Gasket
12. Governor valve
14. Choke shaft lever
15. Choke shaft
- 15A. Choke shaft & lever
16. Choke detent spring
17. Choke detent plunger
18. Choke disc

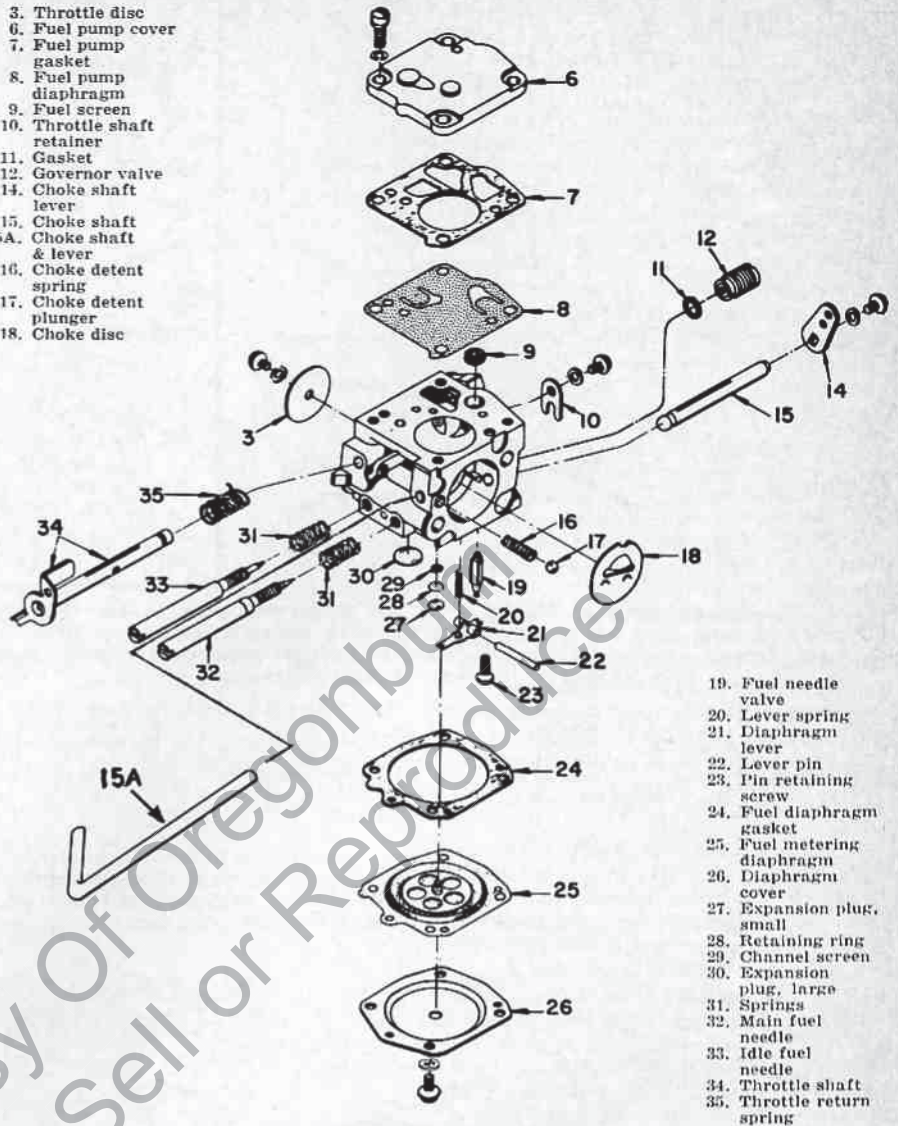

Fig. HL75—Exploded view of Tillotson series HS carburetor; refer to Fig. HL77 for Walbro carburetor. Some models use a one-piece choke shaft and lever (15A) which extends out through grommet in side of air box; refer to Fig. HL79A. Governor valve (12) used on some models limits engine speed when not under load; valve opens at high speed to admit more fuel, thus preventing leaning out and overspeeding.

additional. Open idle mixture adjustment (LO Speed) needle and main mixture adjustment (HI Speed) needle one full turn each.

Make final adjustments with engine warm and running. Adjust idle mixture needle so that engine idles smoothly; then, adjust idle speed screw so that engine idles at just below clutch engagement speed (approximately 2600 RPM). Readjust idle mixture if necessary.

To set main mixture adjustment needle, jam chain in a cut so that clutch slips, turn main mixture needle in until engine falters, then back needle out (about ¼-turn clockwise) until engine carries a full clutch-slipping load. With main mixture needle so adjusted, check engine acceleration. If engine will not accelerate smoothly, open main mixture needle a small amount at a time until engine will accelerate smoothly.

On models with Simplex starting system (decompression valve and adjustable start-

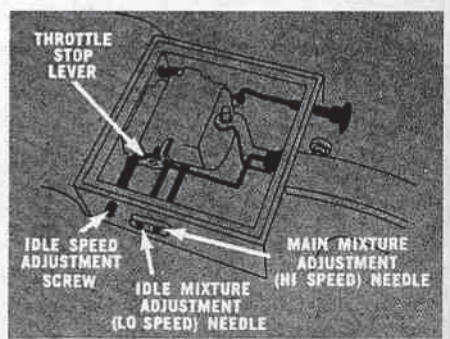

Fig. HL76—Drawing showing locations of fuel mixture adjustment needles, idle speed needle and throttle stop lever.

ing speed), speed at which engine runs with throttle latch engaged can be adjusted by turning eccentric throttle trigger pivot pin (26—Fig. HL79 or 24—Fig. HL79A).

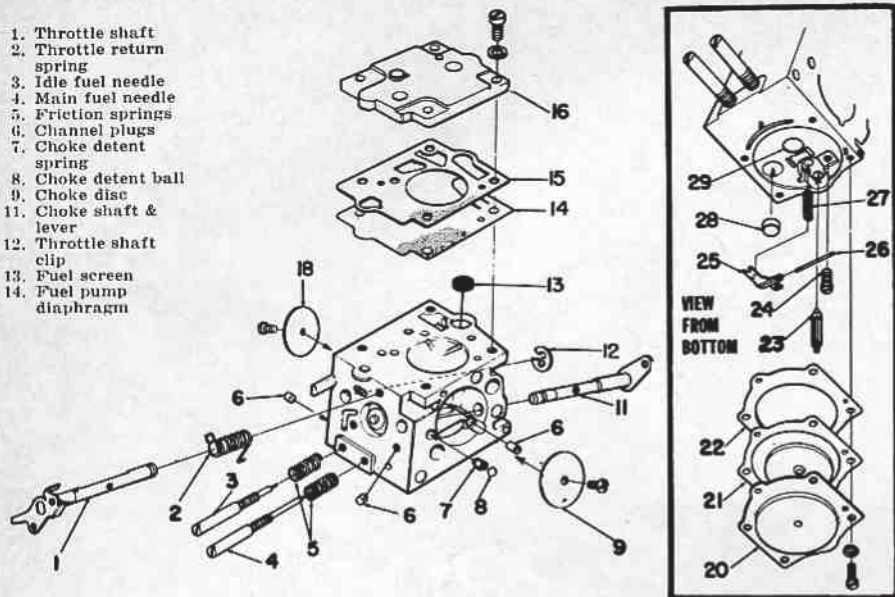

Fig. HL77—Exploded view of Walbro series SDC carburetor; refer to Fig. HL75 for Tillotson carburetor. Inset box at right shows view from bottom of carburetor. Plugs (6) close off channels used for accelerator pump pulse and fuel passages; accelerator pump is not used for this series of chain saw engines.

- | | | | |
|----------------------|------------------------|-------------------------|--------------------|
| 15. Diaphragm gasket | diaphragm cover | 23. Inlet needle valve | 26. Lever pin |
| 16. Fuel pump cover | 21. Metering diaphragm | 24. Pin retaining screw | 27. Lever spring |
| 18. Throttle disc | 22. Diaphragm gasket | 25. Metering lever | 28. Expansion plug |
| 20. Metering | | | 29. Expansion plug |

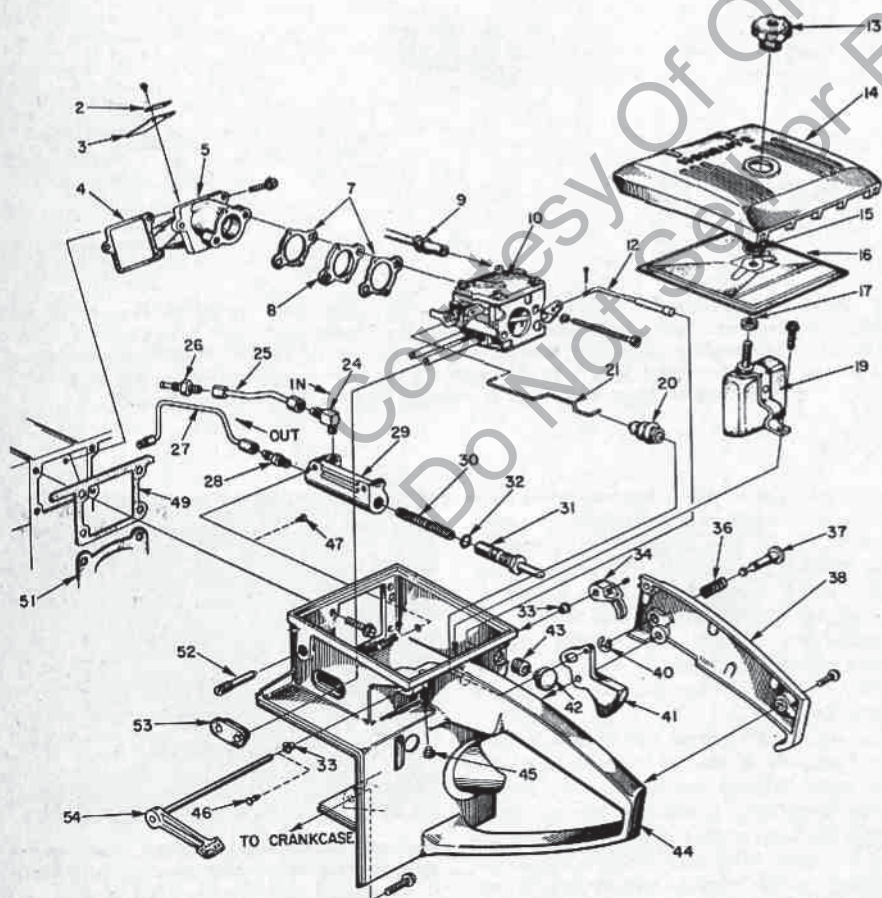

Fig. HL78—Exploded view of air box and handle assembly for early model XL-700. Model XL-800 is not equipped with manual oiler pump (items 24 through 31) and operating lever (34 and 54) although late model XL-800 has provisions for installing same. Model XL-850 and late models XL-700 and XL-800 have "Delrin" pyramid reed seat which does not use reed retaining plates (2) and screws; refer to Fig. HL79.

When servicing Tillotson series HS carburetor, refer to exploded view in Fig. HL75. Slide screen (9) from bore to clean or renew. If passages are choked, plugs (27 and 30) may be removed for cleaning purposes. Drill a 1/8-inch hole through large plug (30) and a 1/16-inch hole through small (nozzle) plug (27), then pry plugs from bores. NOTE: Carefully drill the holes so as not to damage carburetor body; drill should be controlled so that it will just break through the plug. Install new Welch plugs after cleaning carburetor body. Bend diaphragm lever, if necessary, so that lever is flush with floor of diaphragm chamber.

To overhaul Walbro carburetor, refer to exploded views in Fig. HL77 for guide to disassembly and reassembly. Adjust fuel diaphragm lever (25) by bending as necessary so that lever is flush with bosses cast on carburetor body at each side of lever. Plugs (28 and 29) can be removed if necessary as outlined for Tillotson carburetor in preceding paragraph. NOTE: Do not blow compressed air through main nozzle check valve of Walbro carburetor. If valve has

DEPRESS HERE THEN PUSH NEEDLE HERE



HIGH



PRY UP HERE

LOW

Fig. HL78A—Drawing showing proper adjustment of metering diaphragm lever.

- | | |
|----------------------|------------------------|
| 2. Retaining plates | 29. Pump body |
| 3. Inlet valve reeds | 30. Plunger spring |
| 4. Gasket | 31. Pump plunger |
| 5. Elbow & reed seat | 32. "O" ring |
| 7. Gaskets | 33. Bushing |
| 8. Spacer | 34. Oiler lever |
| 9. Fuel tube | 36. Lock spring |
| 10. Carburetor assy. | 37. Throttle latch pin |
| 12. Choke rod | 38. Handle cover |
| 13. Cover nut | 40. Snap ring |
| 14. Air filter cover | 41. Throttle trigger |
| 15. Retaining ring | 42. Choke button |
| 16. Filter element | 43. Grommet |
| 17. Gasket | 44. Throttle handle |
| 19. Air deflector | 45. Rubber bumper |
| 20. Boot | 46. Plug (XL-800) |
| 21. Throttle rod | 47. Plug (XL-800) |
| 24. Check valve | 49. Gasket |
| 25. Oil line | 51. Cylinder gasket |
| 26. Connector | 52. Idle speed screw |
| 27. Oil line | 53. Grommet |
| 28. Check valve | 54. Oil lever & shaft |

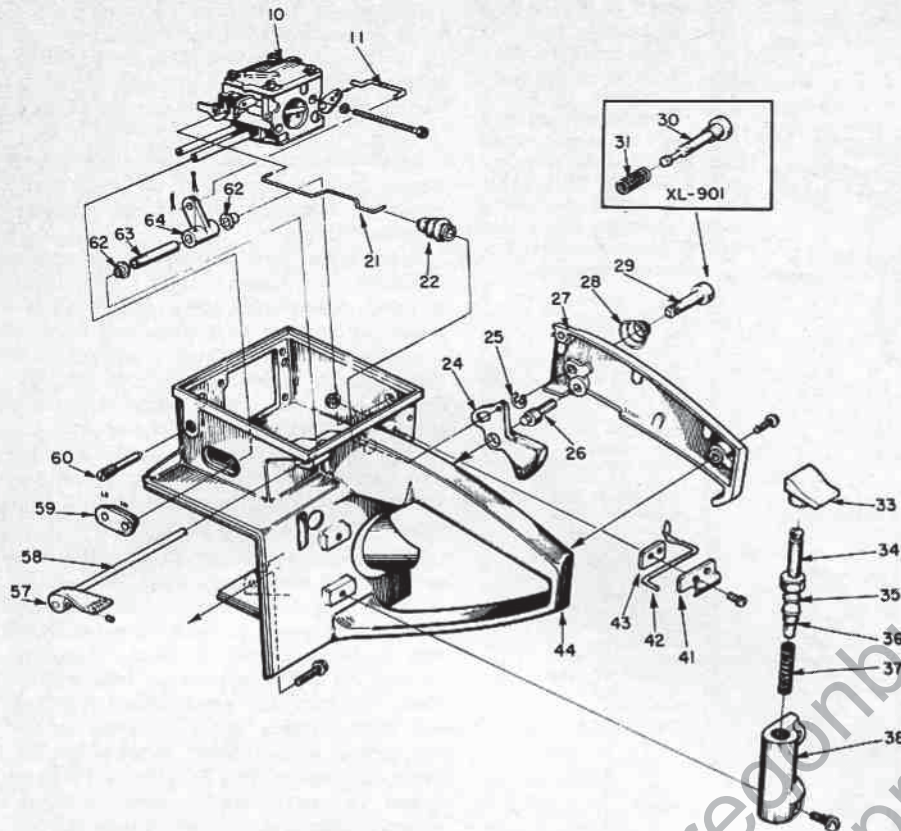

Fig. HL79—On models XL-901, XL-903 and XL-904, choke is actuated by bellcrank (64) mounted on shaft (58) and manual chain oiler pump body (38) is mounted on air box near handle. Compression release lever (42), on models so equipped, is operated by throttle latch (29). Refer to Fig. HL79A for view showing later type single lever choke system.

- | | | | |
|----------------------|------------------------|-------------------------------|----------------------|
| 10. Carburetor | 28. Spring | 37. Compression spring | 57. Choke lever |
| 11. Choke link | 29. Throttle latch pin | 38. Oil pump body | 58. Choke shaft |
| 21. Throttle rod | 30. Throttle latch pin | 41. Lever clamp | 59. Grommet |
| 22. Grommet | 31. Spring | 42. Valve lever | 60. Idle speed screw |
| 24. Throttle trigger | 33. Oiler button | 43. Plate | 62. Bushings |
| 25. Snap ring | 34. Oil pump plunger | 44. Air box (throttle handle) | 63. Spacer sleeve |
| 26. Eccentric pin | 35. Shaft "O" ring | | 64. Choke bellcrank |
| 27. Handle cover | 36. Plunger "O" ring | | |

been removed or damaged, it will be necessary to install a check valve repair kit (Homelite part No. 65386) using a special installation tool (Homelite tool No. 24173).

New service replacement carburetor may not have choke mechanism components, in which case it will be necessary to remove choke mechanism parts from old carburetor and install them in new carburetor, or obtain new choke mechanism parts. New air box (throttle handle) of latest type has holes drilled and plugged for different type choke operating mechanism; remove the plugs applicable to particular type of choke operating system of unit being repaired.

MAGNETO. Three different types of magnetos are used. All models except XL-850, XL-875 and XL-904 are equipped with a conventional flywheel type magneto. Models XL-850, XL-875 and early XL-904 are equipped with a transistorized breakerless magneto. Late model XL-904 units are equipped with a capacitor discharge (CD) magneto. Either the conventional type magneto or the capacitor discharge magneto are available as complete assemblies for service replacement of the solid state magneto. Refer to appropriate following paragraph for service information on each type magneto.

CONVENTIONAL (BREAKER POINT) MAGNETO. Refer to Fig. HL81 for exploded view of magneto. Breaker points and condenser are accessible after removing starter housing, flywheel and breaker box cover. Adjust breaker point gap to 0.015. Condenser capacity should test 0.018-0.022 md. Ignition timing is fixed at 30° BTDC. After reinstalling flywheel, check armature air gap which should be 0.005-0.007. To adjust air gap, turn flywheel so that magnets are below legs of armature core and place plastic shim (Homelite part No. 23987) between armature and magnets. Loosen then tighten armature retaining screws and remove shim. Refer to coil test specifications following FUNDAMENTALS section of this manual.

SOLID STATE (WICO) MAGNETO. Refer to Fig. HL82 for exploded view of the solid state (transistorized breakerless) magneto used on Models XL-850, XL-875 and early XL-904. NOTE: Some of these models may be equipped with service installed conventional flywheel type magneto or later capacitor discharge type magneto.

To check the solid state magneto, disconnect spark plug wire, turn ignition switch on and crank engine while holding terminal about 1/4-inch away from ground (engine casting) and check for spark as with conventional magneto. If no spark occurs, refer to the following inspection and test procedure:

Visually inspect rotor (flywheel) for damage. Check for broken or frayed wires and make sure the primary coil wire terminal is not shorted out to magneto ignition coil armature.

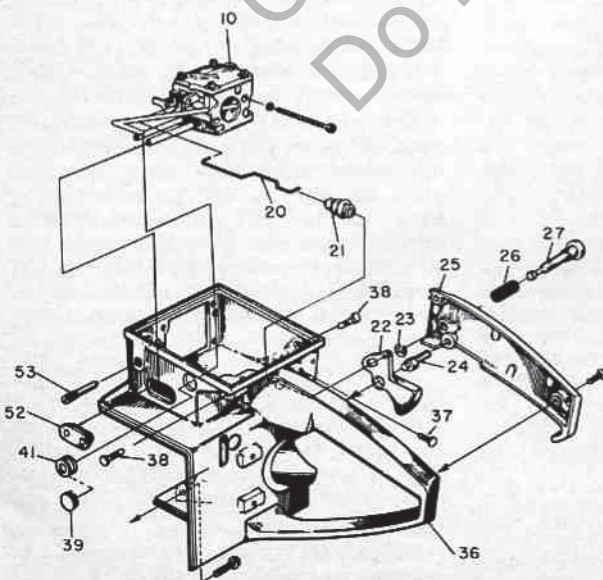

Fig. HL79A—View showing late type air box (throttle handle) and carburetor with single lever choke system. Plugs (37, 38 & 39) allow late type throttle handle to be used on both late type and earlier units.

- | | | | | | | | | | | | | | | | |
|----------------|------------------|-------------|----------------------|---------------|-------------------|------------------|------------|--------------------|-------------------------------|--------------------------|----------------------------|----------------------------|--------------------------|--------------------------|---------------------|
| 10. Carburetor | 20. Throttle rod | 21. Grommet | 22. Throttle trigger | 23. Snap ring | 24. Eccentric pin | 25. Handle cover | 26. Spring | 27. Throttle latch | 36. Air box (throttle handle) | 37. Plug, choke rod hole | 38. Plug, cross shaft hole | 39. Plug, choke lever hole | 41. Grommet, choke lever | 52. Grommet, fuel needle | 53. Idle stop screw |
|----------------|------------------|-------------|----------------------|---------------|-------------------|------------------|------------|--------------------|-------------------------------|--------------------------|----------------------------|----------------------------|--------------------------|--------------------------|---------------------|

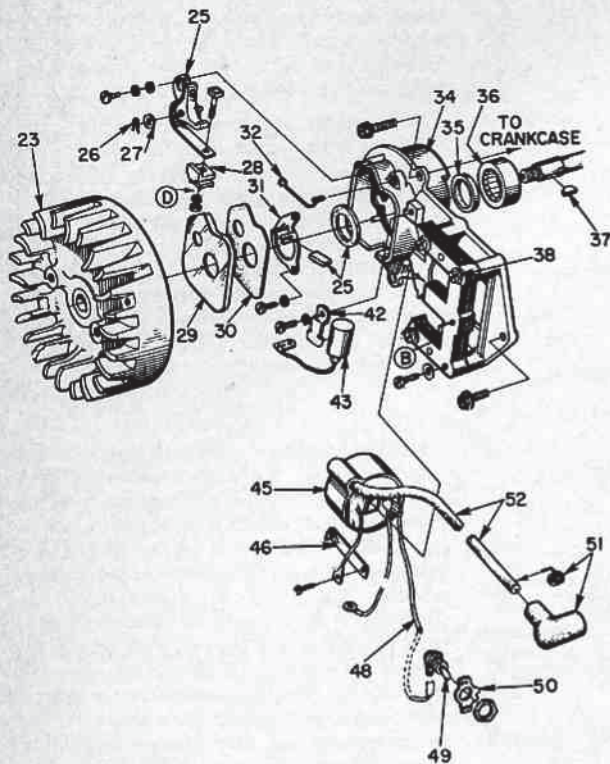

Fig. HL81 — Exploded view of conventional flywheel type magneto. Coil clip retaining screw location is shown by letter "B". Condenser lead and ignition coil primary lead are attached to terminal block (28) at "D". Refer to Fig. HL82 for solid state magneto or to Fig. HL84 for capacitor discharge magneto.

- 23. Rotor (flywheel)
- 25. Breaker point set
- 26. Clip
- 27. Washer
- 28. Terminal block
- 29. Breaker box cover
- 30. Gasket
- 31. Felt retainer
- 32. Cover spring clip
- 34. Back plate
- 35. Crankshaft seal
- 36. Roller bearing
- 37. Rotor key
- 38. Coil core (armature)
- 42. Clamp
- 43. Condenser
- 45. Ignition coil
- 46. Coil retaining clip
- 48. Ground lead
- 49. Ignition switch
- 50. "ON-OFF" plate
- 51. Spark plug terminal
- 52. Spark-plug wire

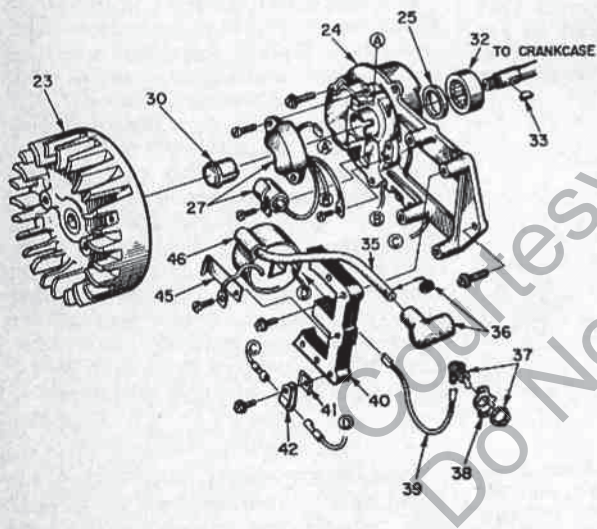

Fig. HL82 — Exploded view of solid state (breakerless) type flywheel magneto. Refer also to Fig. HL83 for conventional type magneto or to Fig. HL84 for capacitor discharge magneto.

- 23. Rotor (flywheel)
- 24. Back plate & trigger coil assembly
- 25. Crankshaft seal
- 27. Condenser & switch
- 30. Dust cap
- 32. Roller bearing
- 33. Rotor key
- 35. Spark plug wire
- 36. Spark plug terminal
- 37. Ignition switch
- 38. "ON-OFF" plate
- 39. Ground lead
- 40. Coil core (armature)
- 41. "D" washer
- 42. Nylon clamp
- 45. Coil clip
- 46. Ignition coil

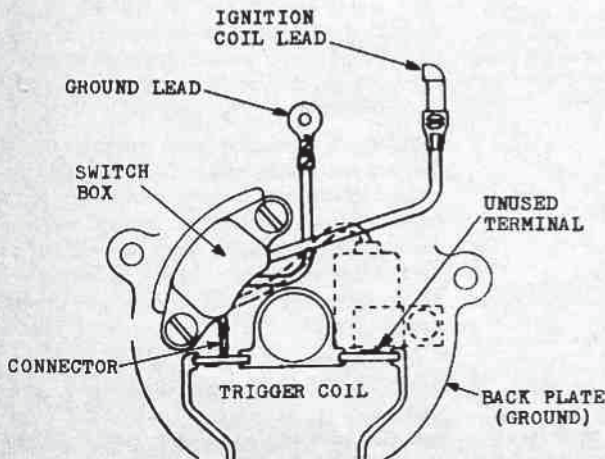

Fig. HL83 — Drawing showing points for ohmmeter test lead connections for checking solid state magneto trigger coil, condenser and switch box. Refer to text for procedure and specifications.

To test the ignition coil, disconnect the wires at terminal (42) and test coil according to tester procedure. Specifications for testing ignition coils are given on page following FUNDAMENTALS section of this manual.

Renew the ignition coil if found faulty and again check for spark. If no spark then occurs or if ignition coil checked OK, proceed as follows:

Remove the flywheel and again check for broken or frayed wires. If no defect is noted, remove the screw attaching condenser to magneto back plate and be sure condenser is not touching back plate or other ground. Push a pin through the condenser lead and using condenser tester, check for short, series resistance and capacity; condenser capacity should be 0.16-0.20 mfd. If condenser is faulty, renew the switch box and condenser assembly. If condenser tested OK, proceed as follows:

Disconnect coil primary (D—Fig. HL82) at terminal and disconnect switch box ground lead (see Fig. HL83). Remove the screw attaching condenser to back plate and be sure condenser is insulated from any ground. Be sure the switch box ground lead and ignition coil lead are not touching anything and connect leads of an ohmmeter to the two leads. Meter should read either between 1 megohm and infinity or between 5 and 25 ohms; with ohmmeter leads reversed, reading should be opposite that of preceding test. That is, if first reading obtained was 5-25 ohms, second reading should be 1 megohm to infinity. If ohmmeter readings are not as specified, renew the switch box and condenser assembly. If switch box tested OK, test trigger coil as follows:

Connect one ohmmeter lead to connector between switch box and trigger coil and other ohmmeter lead to back plate (ground). Reading should be either between 0 to 85 ohms or between 85 and 150 ohms. Reverse the leads; second reading on ohmmeter should be opposite first reading. That is, if first reading was in specified range of 0-85 ohms, second reading should be with range of 85-150 ohms. Then, connect the ohmmeter leads to unused terminal of trigger coil and to magneto back plate. Ohmmeter reading should then be 20 to 26 ohms. If trigger coil does not test within specifications, renew the magneto assembly.

When reassembling magneto, check back plate and remove any sharp edges, especially where wires may contact the back plate. Be sure the "D" washer (41—Fig. HL82) securing the plastic clamp (42) is correctly positioned. Be sure all leads are in place and that terminal connection (42) is parallel with armature core. Be sure the back plate is clean and check all screws for tightness.

CAPACITOR DISCHARGE (CD) MAGNETO. Refer to Fig. HL84 for exploded view of the capacitor discharge (CD) magneto used on late model XL-904; magneto is also available as service replacement of solid state magneto used on models XL-850, XL-875 and early XL-904.

NOTE: Refer to page 86 for explanation of magneto operation.

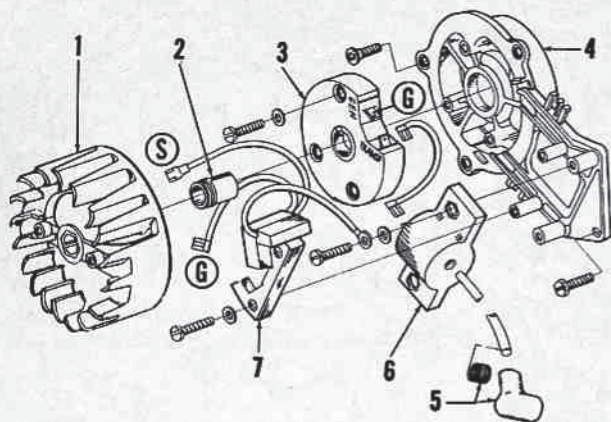

Fig. HL84 — Exploded view of Phelon capacitor discharge type magneto first used on model XL-904 and available for service replacement of magnetos used on models XL-850, XL-875 and early XL-904.

- G. Connector to "Gen." terminal
- S. Connector to "ON-OFF"
- 1. Magneto rotor (flywheel)
- 2. Dust cap
- 3. Ignition module
- 4. Back plate
- 5. High tension wire & terminal
- 6. Transformer coil
- 7. Generator coil & armature

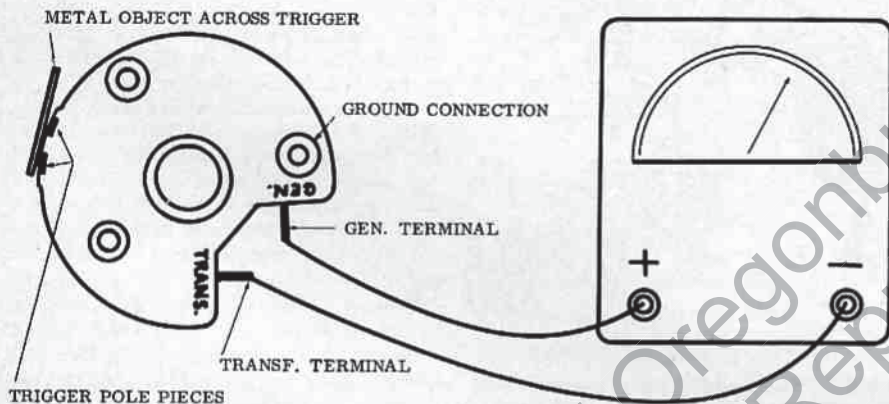

Fig. HL85—Drawing showing volt-ohmmeter connections to ignition module (3—Fig. HL84) for checking module. It should be noted that this is not a conclusive test and module should be renewed in event of spark failure when other magneto components test OK.

The capacitor discharge magneto can be considered OK if spark will jump a 3/8-inch gap when turning engine at cranking speed. If magneto fails to produce spark, service consists of locating and renewing inoperative unit; no maintenance is necessary.

To check magneto with volt-ohmmeter, proceed as follows: Remove starter housing and disconnect wire from ignition switch. Check to be sure there is no continuity through switch when in "ON" position to be sure a grounded switch is not cause of trouble and inspect wiring to be sure it is not shorted. CAUTION: Be sure that storage capacitor is discharged before touching connections; flip ignition switch to "OFF" position or ground switch lead (S).

Resistance through secondary (high tension) winding of transformer coil should be 2400 to 2900 ohms and resistance through primary winding should be 0.2-0.4 ohms. Connect ohmmeter leads between high tension (spark plug) wire and ground, then between input terminal and ground. If transformer coil does not test within specifications, renew coil and recheck for spark at cranking speed. If magneto still does not produce spark, check generator as follows:

Remove rotor (flywheel) and disconnect lead from generator to generator (G) terminal on module (3) and switch lead (S) at ignition switch. Connect negative lead of ohmmeter to ground wire from generator and the posi-

tive lead of ohmmeter to generator (G) wire. The ohmmeter should register showing continuity through generator. Reverse leads from ohmmeter; ohmmeter should then show no continuity (infinite resistance) through generator. Renew generator if continuity is noted with ohmmeter leads connected in both directions. A further check can be made using voltmeter if continuity checked correctly. Remove spark plug and reinstall rotor leaving wire (G) from generator disconnected. Connect positive (red) lead from voltmeter to wire (G) from generator and negative (black) lead of voltmeter to magneto back plate; wires must be routed so that starter can be reinstalled. A firm pull on starter rope should spin engine at about 500 RPM and voltmeter should show minimum reading of 4 volts. If both generator and transformer coil tested OK, a faulty ignition module (3) should be suspected.

A partial check of ignition module can be made using ohmmeter. With ohmmeter set to R X 1000 scale, connect positive (red) lead of ohmmeter to module terminal marked "Gen." and negative ohmmeter lead to module ground connection (see Fig. HL85). An instant deflection of ohmmeter needle should be noted; if not, reverse ohmmeter leads and observe needle. If no deflection of needle is noted with ohmmeter leads connected in either direction, module is faulty and should be renewed. If needle deflection is observed,

select R X 1 (direct reading) scale of ohmmeter and connect positive (red) lead to module terminal marked "Gen." and place negative (black) lead against terminal marked "Trans.". Place a screwdriver across the two trigger poles (see Fig. HL85); the ohmmeter needle should deflect and remain deflected until the ohmmeter lead is released from the module terminal. If the desired results are obtained with ohmmeter checks, the module is probably OK; however, as this is not a complete check and other magneto components and wiring check OK, renew module if no ignition spark can yet be obtained.

LUBRICATION. Engine is lubricated by oil mixed with fuel. Thoroughly mix oil and gasoline in separate container. Mix 1/2-pint of Homelite motor oil, or a good grade non-detergent SAE 30 motor oil, in each gallon of regular gasoline.

Fill chain oiler reservoir with Homelite Bar and Chain oil or a light oil (no heavier than SAE 30). In cold weather, chain oil can be diluted with kerosene to allow easier flow of oil through pump and lines.

The clutch drum and sprocket should be removed and the needle roller bearing and inner race be cleaned and greased occasionally.

CARBON. Muffler and cylinder exhaust ports should be cleaned periodically to prevent loss of power due to carbon build up. Remove muffler cover and baffle plate and scrape muffler free of carbon. With muffler cover removed, turn engine so that piston is at top dead center and carefully remove carbon from exhaust ports with wooden scraper. Be careful not to damage the edges of exhaust ports or to scratch piston. Do not attempt to run engine with muffler baffle plate or cover removed.

REPAIRS

TIGHTENING TORQUE VALUES. Tightening torque values for XL-700 through XL-904 models are as follows: Note: All values are in inch-pounds; minimum torque value is given. To find maximum torque value, add 20% to value given.

| | | |
|--------|--------------------------|-----|
| 4/40 | Outer spring shield | 5 |
| 4/40 | Reeds to seat | 5 |
| 4/40 | Flange bearing, oil pump | 5 |
| 6/32 | Automatic oiler pump | 20 |
| 8/32 | Connecting rod | 55 |
| 8/32 | Reed—elbow assembly | 40 |
| 8/32 | Throttle handle cover | 40 |
| 8/32 | Coil to back plate | 20 |
| 10/32 | Manual oiler | 30 |
| 10/32 | Pulley to fan housing | 50 |
| 10/32 | Screen to rotor | 50 |
| 10/32 | Carburetor to elbow | 50 |
| 10/32 | Muffler cap | 30 |
| 10/32 | Bearing retainer | 55 |
| 12/24 | Handle bar bracket | 80 |
| 12/24 | Back plate to crankcase | 80 |
| 12/24 | Back plate to cylinder | 80 |
| 12/24 | Starter housing | 80 |
| 12/24 | Air filter bracket | 80 |
| 12/24 | Muffler body | 80 |
| 12/24 | Carburetor chamber | 80 |
| 12/24 | Pawl studs to rotor | 80 |
| 1/4-20 | Handle bar to bracket | 100 |
| 1/4-20 | Handle bar to crankcase | 100 |

- 37. Rotor (flywheel)
- 54. Piston & pin
- 55. Snap ring
- 56. Piston rings
- 57. Connecting rod
- 58. Needle bearing
- 59. Needle rollers
- 60. Crankshaft
- 61. Ball bearing
- 62. Bearing retaining screws
- 63. Lock washers
- 64. Snap ring
- 65. Back plate gasket
- 66. Oil filler cap
- 67. Gasket
- 68. Fuel filler cap
- 69. Gasket
- 70. Relief valve
- 71. Fuel pickup
- 72. Filter element
- 73. Flexible line
- 74. Crankcase & tank assy.
- 75. Gasket
- 76. Cap plug
- 77. Crankshaft seal
- 78. Pipe plug
- 81. Elbow fitting
- 82. Fuel line
- 83. Guide bar studs
- 84. Stud retainers (threaded inserts)
- 85. Gasket
- 86. Cam screw
- 87. Gasket
- 88. Automatic oiler pump housing
- 89. Felt seal
- 90. Worm gear
- 92. Pump plunger gear
- 97. Chain oil filter
- 98. Oil line
- 99. Connector
- 100. Oil tube

- 101. "O" ring
- 102. Gasket
- 103. Oil pick-up line
- 104. Oil filter
- 105. Washer
- 106. Cap
- 107. Gasket (same as 49—Fig. HL78)
- 108. Gasket (same as 51—Fig. HL78)
- 111. Cylinder
- 112. Spark plug
- 115. Muffler body
- 117. Baffle
- 118. Muffler cap
- 119. Shoulder screws

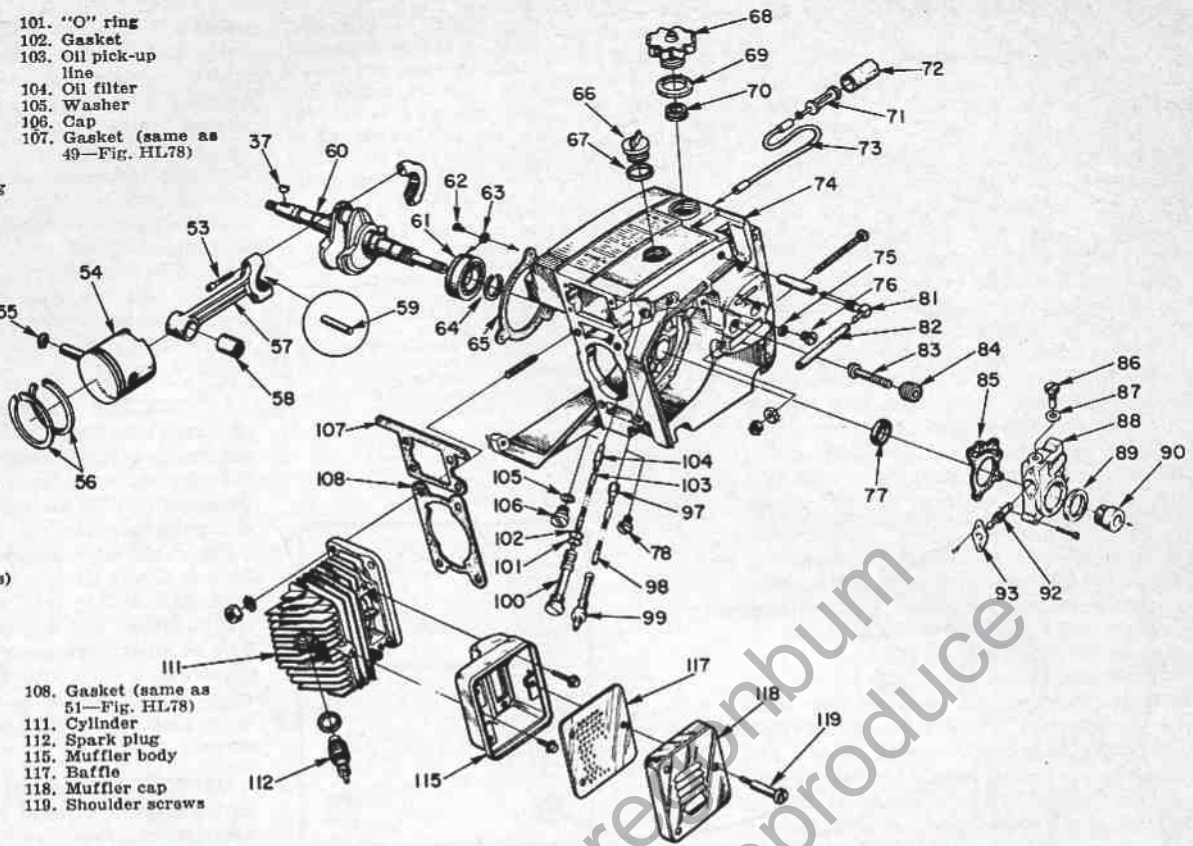

Fig. HL86—Exploded view of typical engine assembly. Some models are not equipped with automatic chain oiler pump assembly (items 85 through 93). Note that to remove the guide bar studs (83), the stud retainers (84) must be unscrewed from crankcase and tank assembly (74); do not attempt to unscrew the studs. Refer to Fig. HL86A for XL-903 and XL-904 models with compression relief valve. Fig. HL89 shows later type crankcase with removable fuel tank and with sawdust shield used in place of gasket (85).

- 3/8-24 Clutch nut 150
- 3/8-24 Rotor nut 150
- 1/4-28 Cylinder nuts 100
- 14MM Spark plug 250
- Clutch spider or plate 180

RECOMMENDED SERVICE TOOLS. Special tools for servicing models XL-700 through XL-904 are as follows:

| Tool No. | Description & Model Usage |
|------------------|---|
| 23987 | Shim, magneto air gap, all models except with capacitor discharges except with capacitor discharge magneto. |
| 24306 | Shim, capacitor discharge magneto air gap. |
| 23955 or 23955-1 | Plug, connecting rod bearing installation, all models. |
| A-23137 | Jackscrew, crankshaft and bearing, XL-700 and XL-901 only. |
| A-23965 | Jackscrew, crankshaft and bearing, all models, except XL-700 and XL-901. |
| 23136 | Jackscrew body, model XL-700 only. |
| 23136-1 | Jackscrew body, all models except XL-700 and XL-901. |
| 23136-2 | Jackscrew body, model XL-901 only. |
| 22820-3 | Collar, main bearing installation, models XL-700 and XL-901 only. |
| 22820-4 | Collar, main bearing installation, all models except XL-700 and XL-901. |

| | |
|-----------|---|
| 23759 | Sleeve, crankcase seal protector, models XL-700 and XL-901 only. |
| 23871 | Sleeve, crankcase seal protector, all models except XL-700 and XL-901. |
| 23972 | Sleeve, crankcase seal installation, all models. |
| 23957 | Plug, crankcase seal installation, all models. |
| A-23696 | Wrench, clutch spider, all models with garter spring type clutch. |
| A-23934 | Wrench, clutch plate, all models with late compression spring type clutch. |
| A-23841 | Wrench, bar stud retainer remover, models XL-700-800-850-900. |
| A-23841-A | Wrench, bar stud retainer remover, models XL-870-875-901-903-904. |
| A-23960 | Puller, flywheel (magneto rotor), all models. |
| 23819 | Plug, sprocket bearing, models XL-700 and others with small diameter bearing. |
| 23420 | Plug, sprocket bearing, models with large diameter bearing. |
| 23956 | Plug, back plate bearing and seal, all models. |
| A-23962 | Jackscrew, back plate bearing, all models. |
| 23846-2 | Anvil, back plate bearing, all models. |
| A-23951 | Remover, piston pin, piston with with Spirol pin. |

| | |
|---------|---|
| 22828 | Pliers, piston pin snap ring, all models except with Rulon plastic pin retaining plugs. |
| 23846-1 | Anvil, crankshaft installation, all models. |
| 23846-2 | Anvil, back plate bearing, all models. |
| 24006-1 | Aligning plate, crankshaft installation, all models. |
| 24304 | "Poizdriv" screwdriver bit. |
| 24230 | "Poizdriv" hand screwdriver. |

CYLINDER. The cylinder bore is chrome plated. Renew cylinder if chrome plating is worn away exposing the softer base metal.

To remove cylinder, first remove the blower (fan) housing, carburetor and air box (handle) assemblies and remove the screw retaining magneto back plate to flywheel side of cylinder. The cylinder can then be unbolted from crankcase and removed from the piston.

COMPRESSION RELIEF VALVE. Models XL-903, XL-903E, XL-903EAM and XL-904 are equipped with a compression relief (decompression) valve. The poppet type relief valve is mounted in a port adjacent to exhaust port as shown in Fig. HL86A. The valve is opened as throttle lock plunger is depressed to lock position. If valve fails to close when throttle lock plunger is released, either remove valve and clean using a carbon sol-

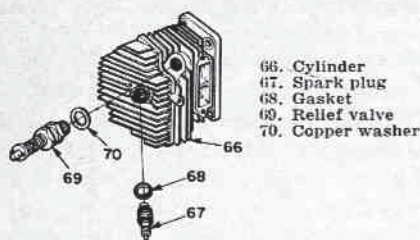

Fig. HL86A—XL-903 and XL-904 models are equipped with a compression relief valve (69).

vent or renew the valve assembly. Copper sealing washer is available separately.

PISTON, PIN AND RINGS. Except for late model XL-875, all models are equipped with piston fitted with two pinned compression rings. Desired ring side clearance in groove is 0.002-0.003; renew the piston if side clearance in top groove with new ring is 0.0035 or more. Recommended piston ring end gap is 0.070-0.080; maximum allowable ring end gap is 0.085. Piston, pin and rings are available in standard size only. Pin and piston are available, fitted set only.

Late model XL-875 is equipped with piston having a single head-land type ("L" shaped) piston ring with ring locating pin. Ring end gap at outer edge of ring with ring in cylinder bore should be 0.010-0.020. A ring end gap of more than 0.020 would indicate ring is worn and should be renewed. Ring side clearance in groove can be measured only at flat side of ring (side away from closed end of piston). Desired side clearance in ring groove is 0.001-0.004. NOTE: Piston with head land ring should not be used to renew early model XL-875 piston with two pinned rings unless a new unworn cylinder is also installed.

Different methods of retaining piston pin have been used. Early models were equipped with piston fitted with non-removable Spirol pin through pin boss at exhaust side of piston and a Waldes Truarc snap ring at intake side. Later models and service replacement piston for early models utilize a non-removable snap ring at exhaust side of piston instead of the Spirol pin. A third method of retaining piston pin is using "Rulon" (thermal plastic) plugs that snap into pin bore of piston at end of piston pin.

To remove piston pin retained with snap ring at intake side of piston, remove the snap ring using special pliers (Homelite tool No. 22828). On early type piston with Spirol pin at exhaust side, push piston pin out towards intake side using slotted remover (Homelite tool No. A-23951). On models with snap ring at exhaust side of piston, insert a 3/16-inch diameter rod through snap ring and push pin from piston. On models with "Rulon" retaining plugs, pry the plugs from piston, then push piston pin out.

When installing piston pin, be sure closed end is towards exhaust side of piston (away from piston ring locating pin). On models with snap ring at intake side of piston (all models except those with "Rulon" plugs), insert snap ring using special pliers; sharp

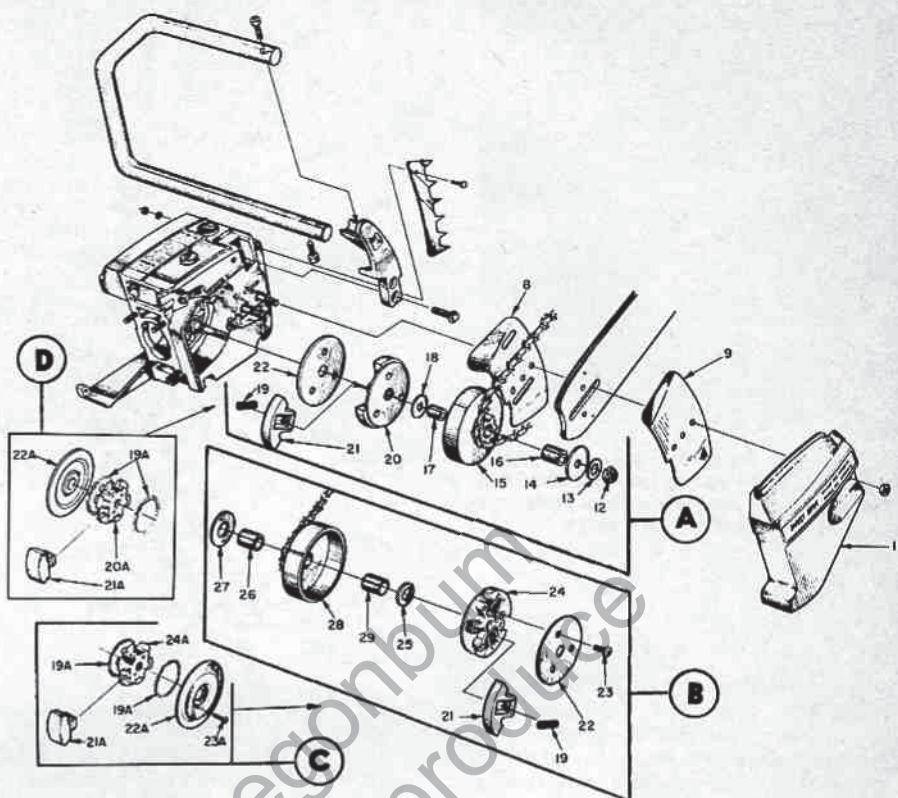

Fig. HL87—View showing different clutches used on XL-700 through XL-904 series of saws. Refer to Fig. HL88 for assembly of late type (views A & B) clutch shoes (21) and springs (19) to clutch plate (20 or 24). Clutch shoes should be renewed in complete sets only to maintain balance of clutch assembly. On models XL-901 and late XL-700, clutch construction is as shown in View "A". Early model XL-700 clutch is shown in View "D". Models XL-870, XL-875 and early XL-800 use clutch shown in View "C". All other models have clutch as shown in View "B".

- | | | | |
|----------------------------|----------------------------|---------------------------|----------------------------|
| 8. Inner guide plate | 16. Needle roller bearing | 21. Clutch shoe (late) | 24. Clutch plate (late) |
| 9. Outer guide plate | 17. Inner race | 21A. Clutch shoe (early) | 25. Outer thrust washer |
| 11. Clutch cover | 18. Inner thrust washer | 22. Clutch cover (late) | 26. Inner race |
| 12. Crankshaft nut | 19. Clutch spring (late) | 22A. Clutch cover (early) | 27. Inner thrust washer |
| 13. Flat washer | 19A. Clutch spring (early) | 23. Socket head screws | 28. Clutch drum & sprocket |
| 14. Outer thrust washer | 20. Clutch plate (late) | 23A. Button head screws | 29. Needle roller bearing |
| 15. Clutch drum & sprocket | 20A. Clutch spider (early) | | |

edge of snap ring must be out and locate end gap towards closed end of piston. On models with "Rulon" plugs, use new plugs when reassembling piston to connecting rod.

CONNECTING ROD. Connecting rod and piston assembly can be removed after removing cylinder from crankcase. Be careful to remove all of the 28 loose needle rollers when detaching rod from crankpin.

Renew connecting rod if bent or twisted, or if crankpin bearing surface is scored, burned or excessively worn. The caged needle roller piston pin bearing can be renewed by pressing old bearing out and pressing new bearing in with Homelite tool No. 23955 or 23955-1. Press on lettered end of bearing cage only.

It is recommended that the crankpin needle rollers be renewed as a set whenever engine is disassembled for service. Stick 14 needle rollers in rod and the remaining 14 needle rollers in rod cap with

light grease or beeswax. Assemble rod to cap with match marks aligned and with open end of piston pin towards flywheel side of engine. Wiggle the rod as cap retaining screws are being tightened to align the fractured surfaces of rod and cap.

CRANKSHAFT. Flywheel end of crankshaft is supported in a roller bearing in magneto back plate and drive end is supported in a ball bearing located in crankcase. End play is controlled by the ball bearing.

Renew the crankshaft if the flywheel end main bearing or crankpin bearing surface or sealing surfaces are scored, burned or excessively worn. Renew the ball bearing if excessively loose or rough. Also, reject crankshaft if flywheel keyway is beat out or if threads are badly damaged.

CRANKCASE, MAGNETO BACK PLATE AND SEALS. To remove the magneto back plate, first remove the blower (fan) housing,

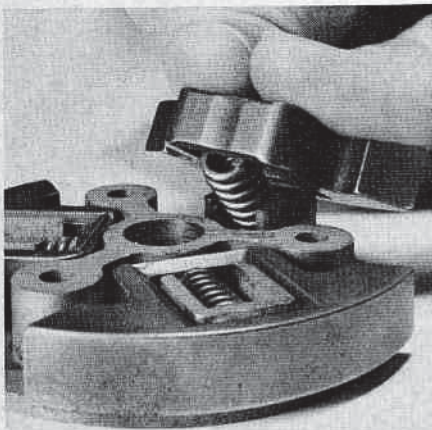

Fig. HL88—To install late type clutch shoe and spring, place spring between shoe and plate as shown, hook shoe onto plate and push shoe down into place.

flywheel and (except on model XL-850) breaker point assemblies. Loosen the cylinder retaining stud nuts on flywheel side of engine to reduce clamping effect on back plate boss, then unbolt and remove the back plate assembly from crankcase.

To remove crankshaft from crankcase, first remove the cylinder, connecting rod and piston assembly and the magneto back-plate as previously outlined. Remove the drive clutch assembly and, on models so equipped, the automatic chain oiler drive worm and pump from drive end of crankcase and shaft. Then, remove the two ball bearing retaining screws (62—Fig. HL86) from inside of crankcase and remove the crankshaft and ball bearing assembly from crankcase. Remove snap ring (64) and press crankshaft from bearing if necessary.

REED VALVES. All models are equipped with pyramid reed valves. On early models XL-700 and XL-800, the four 0.005 thick reeds are retained to the metal pyramid seat by retaining plates and screws.

On later models the pyramid seat is of "Delrin" plastic and the 0.004 thick reeds are located by pins moulded in the seat. The reeds are held in place by a moulded retainer that also serves as a gasket between reed seat and crankcase. Reeds for the previous diecast metal seat are 0.005 thick whereas reeds for the late type "Delrin" seat are 0.004 thick. Do not attempt to interchange reeds between metal and "Delrin" type seats.

When installing latest type intake elbow and "Delrin" seat assembly, insert reed retainer into crankcase first. Stick reeds to seat with oil, then insert seat with reeds. Also, it is important that the special shoulder type retaining screws be installed.

CLUTCH. Early models XL-700 and XL-800 were equipped with a six-shoe clutch as shown in the exploded views (C & D—Fig. HL87). All later models are equipped with a three-shoe clutch as shown in views A & B.

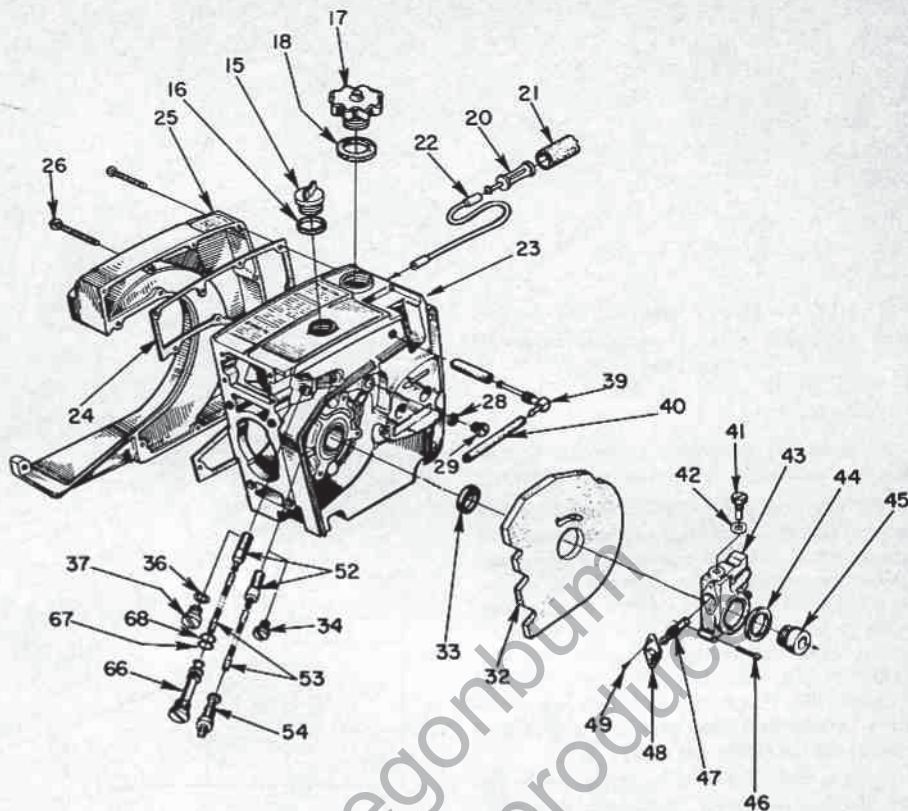

Fig. HL89—Exploded view showing automatic chain oiler pump, manual and automatic oiler pick-ups, crankcase and oil reservoir and fuel tank. Automatic oil pump plunger (47) and pump body (43) are available as a matched set only. Plug (34) is used to seal opening when saw is not equipped with manual chain oiler; plug (37) and washer (36) are used on models not equipped with automatic chain oiler. On late models, fuel tank cover (25) is sealed to crankcase and chain oil reservoir with gasket (24); early units were equipped with integral epoxied unit.

- | | | | |
|-------------------|-----------------------|---------------------------|------------------------|
| 15. Chain oil cap | 25. Fuel tank | 39. Elbow | 47. Pump rear/plunger |
| 16. Gasket | 26. Tank cover screws | 40. Fuel line | 48. Flanged bearing |
| 17. Fuel tank cap | 27. Gasket | 41. Oil pump cam | 49. Oil pick-ups |
| 18. Gasket | 28. Gasket | 42. Gasket | 50. Screws |
| 20. Pickup head | 29. Cap | 43. Oil pump body | 52. Oil pick-ups |
| 21. Fuel filter | 32. Saw dust shield | 44. Felt seal | 53. Flexible oil lines |
| 22. Flexible line | 33. Crankshaft seal | 45. Worm gear | 54. Connector |
| 23. Crankcase | 34. Plug | 46. Pump retaining screws | 65. Oil line tube |
| 24. Gasket | 36. Sealing washer | | 67. Gasket |
| | 37. Plug | | 68. "O" ring |

To remove either the early or late type clutch, proceed as follows: On models with clutch outside of chain first remove screws retaining clutch cover (22 or 22A) to clutch spider (24 or 24A) and remove cover. Unscrew the clutch spider from crankshaft using a spanner wrench (Homelite tool No. A-23696 for early type or No. A-23934 for late type clutch). The clutch drum, bearing and inner race can then be removed from crankshaft.

On models with clutch inside chain, remove nut from drive end of crankshaft and slide clutch drum and inner race from shaft. Then, using spanner wrench (Homelite tool No. A-23696 for early type or No. A-23934 for late type clutch), unscrew spider from crankshaft.

To disassemble early type clutch, remove the two clutch springs (19A), then remove shoes from spider. On late type clutches, pry shoes (21) from clutch plate (20 or 24) with a screwdriver; place shop towel over clutch assembly to keep springs (19) from flying out as shoe is removed.

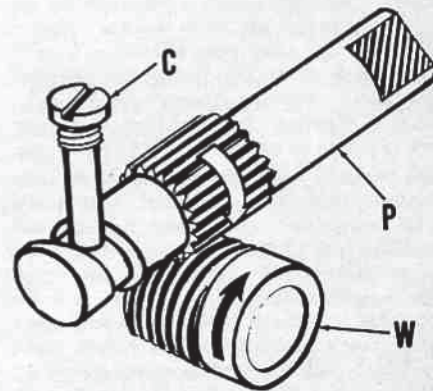

Fig. HL90—Schematic diagram of automatic chain oiler pump operation. Worm gear (W) on crankshaft drives (rotates) pump plunger (P). Cam cut in plunger rides against cam screw (C) causing plunger to move back and forth as it rotates. Flat on plunger acts as a valve as it opens intake port on downward stroke and outlet port on upward stroke.

When reassembling early type clutch, be sure the identifying marks on the shoes are all to same side of the assembly. To reassemble late type clutch, refer to Fig. HL88.

CHAIN OILER. Saws may be equipped with a manual chain oiler pump only, with both a manual pump and an automatic chain oiler pump or with an automatic chain oiler pump only; refer to design features listing. On model XL-800 starting with serial No. 2201258 and on other models with automatic oiler only, the crankcase and oil reservoir are drilled and tapped so that a manual chain oiler pump can be installed if so desired.

The manual oiler pump is installed as shown in Fig. HL78 or Fig. HL79; these illustrations show exploded view of the pump assembly. Usually, service of the manual pump consists of renewing the plunger and shaft "O" rings.

To service the automatic chain oiler pump, the clutch drum and spider must first be removed from the crankshaft as outlined in a preceding paragraph. Refer to Fig. HL90 for operational diagram of pump and to Fig. HL89 for exploded view of pump assembly.

REWIND STARTER. Refer to Fig. HL91 for exploded view of the ratchet type rewind starter used on early models and to Fig. HD92 for late type starter. To disassemble starter after removing fan housing and starter assembly from saw, proceed as follows:

On models with slotted rope pulley, pull rope fully out, hold pulley from turning and pry knot end of rope from pulley. Allow pulley to rewind slowly.

On models without slot in pulley, pull rope outward a short distance, hold rope, pry retainer from starter handle and untie knot in outer end of rope. Allow pulley to rewind slowly.

Then, on all models, remove the socket head screw, flat washer cup and rope pulley. **CAUTION:** Be careful not to dislodge rewind spring while removing starter cup and pulley as the rapidly uncoiling spring could cause injury. Rope bushing, starter post bushing, and/or rewind spring bushing in housing should be renewed if worn.

When reassembling starter, lubricate starter port lightly and install spring dry (without lubrication).

Reassemble starter using exploded view in Fig. HL91 or Fig. HL92 as a guide. Pre-rewind spring about 2-4 turns.

Fig. HL91 — Exploded view of ratchet type starter used on early models. Refer also to Fig. HL92.

- 2. Starter housing
- 3. Rope guide
- 4. Starter rope
- 7. Plastic disc
- 8. Rewind spring
- 9. Plastic disc
- 10. Rope pulley
- 11. Starter cup
- 12. Flat washer
- 13. Screw

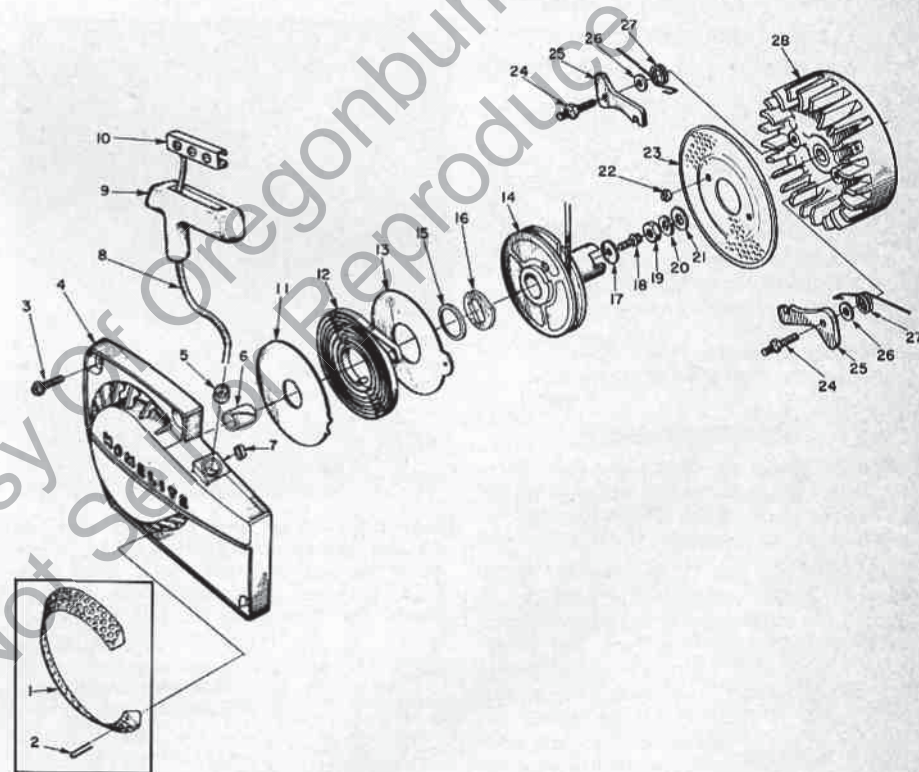
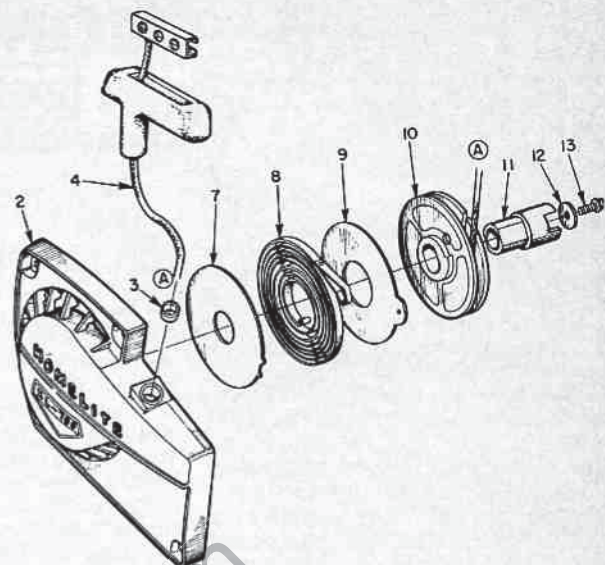

Fig. HL92—Exploded view of late type starter. Note that fan housing (4) has renewable starter post bushing (6) and rewind spring bushing (7). Also, pulley and starter cup are an integral unit (14). Separate spring lock (16) and spring lock bushing (15) are used. Screen (1) and attaching clips (2) are optional equipment.

- | | | | |
|--------------------------|-------------------------|--------------------------|----------------------|
| 1. Screen | 8. Starter rope | 14. Starter pulley | 21. Flat washer |
| 2. Fastener clips | 9. Handle | 15. Spring lock bushing | 22. Lock nuts |
| 3. Hex head screws | 10. Rope retainer | 16. Spring lock | 23. Rotating screen |
| 4. Fan housing | 11. Inner spring shield | 17. Retaining washer | 24. Pawl studs |
| 5. Rope bushing | 12. Rewind spring | 18. Hex head screw | 25. Starter pawls |
| 6. Starter post bushing | 13. Outer spring shield | 19. Flywheel (rotor) nut | 26. Washers |
| 7. Rewind spring bushing | | 20. Lock washer | 27. Pawl springs |
| | | | 28. Flywheel (rotor) |

HOMELITE

A **Textron** DIVISION
 PORT CHESTER, N.Y. U.S.A.

MODEL COVERAGE

| CHAIN SAW MODEL | DESIGN FEATURES |
|------------------|-----------------|
| XL-101 | A,C,D,G,H,J |
| XL-102 | B,C,D,F,H,J |
| XL-102 Automatic | B,C,D,G,H,K |
| XL-103 | B,C,D,F,H,K |
| XL-103E | B,C,D,F,H,K |
| XL-104 | B,C,E,F,H,K |
| XL-104E | B,C,E,F,H,K |

DESIGN FEATURES CODE

- A—Displacement, 3.3 cu. in.; bore, 1 3/4 in.; stroke, 1 3/8 in.
- B—Displacement, 3.5 cu. in.; bore, 1 1/2 in.; stroke, 1 3/8 in.
- C—Pyramid reed type intake valve, 4 reeds.
- D—Equipped with conventional flywheel type magneto.
- E—Equipped with solid state (transistorized breakerless) flywheel magneto.
- F—Equipped with compression release.
- G—Without compression release.
- H—Direct drive.
- J—Manual chain oiler only.
- K—Automatic and manual chain oiler.

MAINTENANCE

SPARK PLUG. A Champion CJ-6 "bantam" spark plug is used in all models. Set electrode gap to 0.025. Tighten plug to torque of 250 inch-pounds.

CARBURETOR. A Walbro model SDC-1 or model SDC-12 carburetor is used on all models. The diaphragm type carburetor also incorporates a diaphragm type fuel pump and a diaphragm type accelerator pump. Fig. HL100 shows carburetor adjustment points; refer to Figs. HL101 and HL102 for exploded views of carburetor. Model SDC-1 and SDC-12 carburetors are alike except for accelerator and fuel pump covers, fuel pump gasket and choke shaft.

For initial adjustment of carburetor, refer to Fig. HL100 and proceed as follows: Back out the idle speed screw (IS) until it clears throttle shaft arm and gently close both fuel mixture needles (LO and HI). Open idle fuel needle (LO) about 3/4 to 1 turn and open main fuel needle (HI) 1 to 1 1/4 turns. Turn idle speed screw (IS) in slowly until it contacts throttle shaft arm, then continue turning screw in 1 1/2 turns. Note: Flip throttle trigger when turning idle speed screw in; a sharp click will be heard when screw is in far enough to contact throttle shaft arm.

Make final carburetor adjustment with engine warm and running. Adjust idle speed screw so that engine is idling at just below clutch engagement speed; do not try to make engine idle any slower than this. Adjust idle fuel needle for best engine idle

performance, keeping the mixture rich as possible (turn needle out to richen mixture). If necessary, readjust idle speed screw. Adjust main fuel needle while engine is under load cutting wood so that engine runs at highest speed without excessive smoke.

The carburetor can be unbolted and removed from adapter (37—Fig. HL103) after removing air filter cover, filter and cover

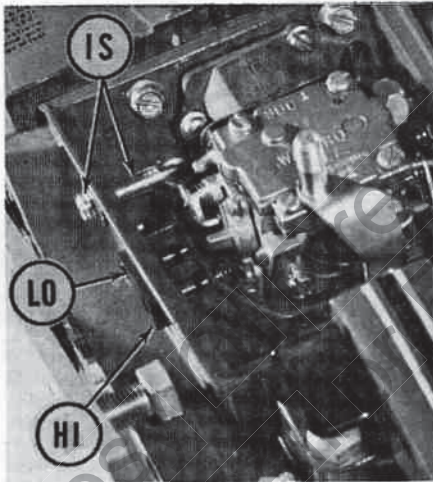

Fig. HL100—View with air filter removed showing carburetor adjusting points. Early model air box and idle speed screw have 5/16-18 thread; late models have 5/16-24 thread for more accurate idle speed adjustment.

HI, High speed needle
 IS, Idle speed screw
 LO, Idle fuel needle.

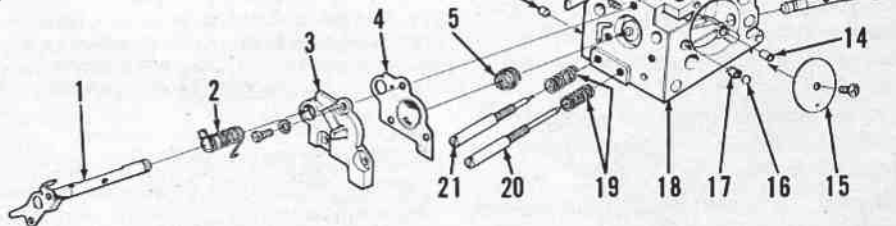

Fig. HL101—Exploded view of Walbro SDC-1 carburetor assembly except for metering diaphragm, lever and inlet valve assembly; refer to Fig. HL102 for exploded view of these parts. Note that throttle shaft (1) extends through accelerator diaphragm (4) and cover (3). Model SDC-12 is similar.

- | | | |
|--------------------------|--------------------------|------------------------|
| 1. Throttle shaft | 7. Throttle valve (disc) | 15. Choke valve (disc) |
| 2. Return spring | 8. Fuel pump diaphragm | 16. Detent ball |
| 3. Pump cover | 9. Gasket | 17. Detent spring |
| 4. Accelerator diaphragm | 10. Pump cover | 18. Carburetor body |
| 5. Spring | 11. Elbow fitting | 19. Springs |
| 6. Limiting plug | 12. "E" ring | 20. High speed needle |
| | 13. Choke shaft | 21. Idle fuel needle |
| | 14. Idle air jet | |

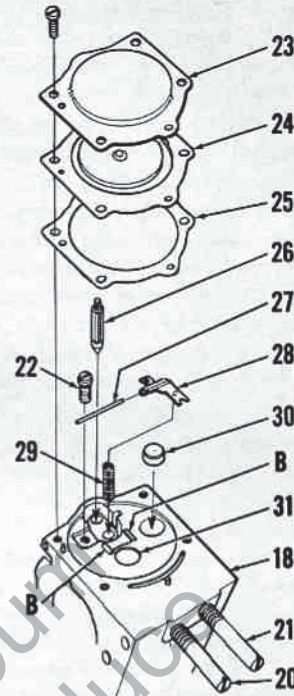

Fig. HL102—Bottom view of carburetor showing exploded view of metering diaphragm, lever and inlet valve assembly. Refer to Fig. HL101 for exploded view of other carburetor parts.

- | | |
|-----------------------|-----------------------|
| 18. Carburetor body | 25. Gasket |
| 20. High speed needle | 26. Inlet valve |
| 21. Idle fuel needle | 27. Lever pin |
| 22. Lever pin screw | 28. Inlet lever |
| 23. Diaphragm cover | 29. Metering spring |
| 24. Diaphragm | 30. Idle passage plug |
| | 31. Main channel plug |

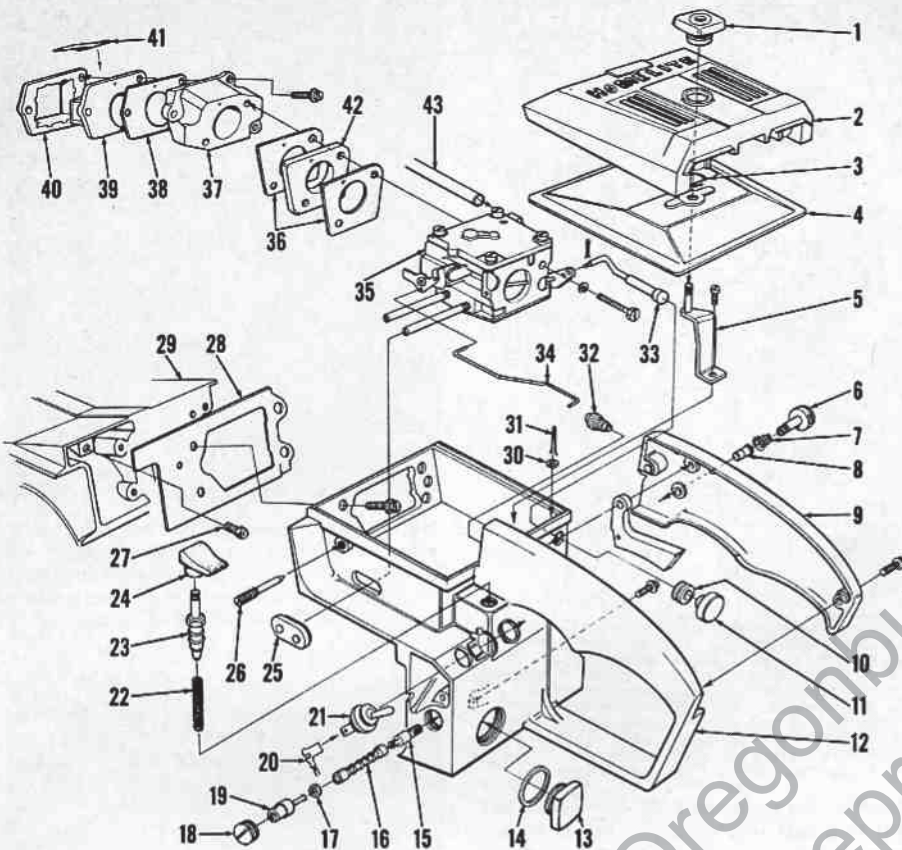
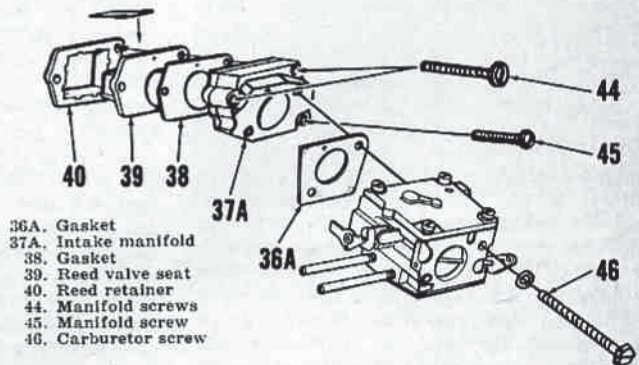

Fig. HL103—Exploded view of throttle handle, air box chain oiler tank assembly and related parts. When cementing new gasket (28) to crankcase (29), insert reed valve retainer (40) in crankcase opening to align gasket. Fuel tank is vented to carburetor chamber in air box through vent valve (27). Refer to Fig. HL103A for late type intake manifold (37) installation. Oil reservoir cover is separate from throttle handle on late models; refer to Fig. HL103B.

- | | |
|---------------------|---------------------------|
| 1. Knob | 23. Pump plunger |
| 2. Air filter cover | 24. Oil pump button |
| 3. Snap ring | 25. Grommet |
| 4. Filter element | 26. Idle speed stop screw |
| 5. Bracket | 27. Fuel tank vent |
| 6. Throttle latch | 28. Gasket |
| 7. Spring | 29. Crankcase |
| 8. Bushing | 30. Felt washer |
| 9. Handle cover | 31. Cotter pin |
| 10. Grommet | 32. Boot |
| 11. Choke knob | 33. Choke rod |
| 12. Throttle handle | 34. Throttle rod |
| 13. Oil tank cap | 35. Carburetor |
| 14. Gasket | 36. Gaskets |
| 15. Oil filter | 37. Intake manifold |
| 16. Flexible tube | 38. Gasket |
| 17. Gasket | 39. Reed valve seat |
| 18. Plug | 40. Reed retainer |
| 19. Check valve | 41. Valve reeds |
| 20. Ground lead | 42. Heat insulator |
| 21. Ignition switch | 43. Fuel tube |
| 22. Spring | |

Fig. HL103A — View showing late type intake manifold (37A) installation. One gasket (36A) is used instead of two gaskets (36 — Fig. HL103) and spacer (42 — Fig. HL103) previously used. Late type manifold is available with installation kit for earlier models.



- | |
|----------------------|
| 36A. Gasket |
| 37A. Intake manifold |
| 38. Gasket |
| 39. Reed valve seat |
| 40. Reed retainer |
| 44. Manifold screws |
| 45. Manifold screw |
| 46. Carburetor screw |

Fig. HL103B — Oil tank cover (48) is sealed to throttle handle (12A) with gasket (47) on later models. An oil tank repair (gasket) kit is available for resealing epoxied cover on earlier models. Idle speed adjusting screw (26A) on late throttle handle has 5/16"-24 thread for more accurate idle speed adjustment. Grommet (10A) is used to seal fuel line air box entry. "Pozidriv" screws (49) retain cover to throttle handle. Plug (50) is used on models XL-101 and XL102 to seal automatic oiler opening

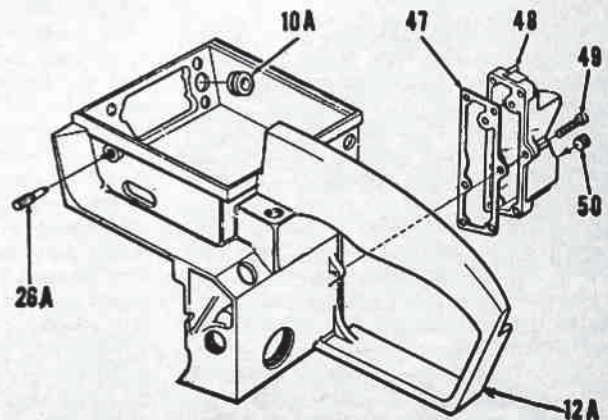

retaining bracket (5). Pry fuel line from inlet fitting and disconnect choke rod. Tilt carburetor and pull adjusting screws from grommet in air box, unhook throttle rod from throttle lever and remove the carburetor. Remove the heat insulator (spacer) (42) and gaskets (36).

Refer to exploded views in Figs. HL101 and HL102 for disassembly and reassembly guide. To renew accelerator pump diaphragm (4) and/or spring (5) it is first necessary to remove throttle disc and the "E" ring (12) from throttle shaft and remove shaft from carburetor. After reassembly of inlet valve (26) and diaphragm lever (28), lever

should be flush with bosses (B) at each side of lever. Note: Do not blow compressed air through the main nozzle check valve. If the valve has been damaged or removed, it will be necessary to install a check valve repair kit (Homelite part No. 65386) using a special installation tool (Homelite tool No. 24173).

When reinstalling carburetor on early models, stick gaskets to spacer and stick spacer and gasket assembly to carburetor with tacky grease to aid in reinstalling unit to adapter. Tighten retaining screws evenly to a torque of 50 inch-pounds. On late models without spacer, install carburetor with new gasket and tighten screws evenly to a torque of 25 inch-pounds. Note: A kit is available to install late type manifold on early model saws.

MAGNETO (Except XL-104). Refer to Fig. HL104 for exploded view of the conventional flywheel type Wico magneto used on all models except XL-104 and XL-104E.

Breaker points and condenser are accessible after removing the fan housing and starter assembly, flywheel and breaker cover. A pry slot is provided to facilitate breaker point gap adjustment using screwdriver as shown in Fig. HL105. Adjust breaker point gap to 0.015 if not renewing points. Homelite recommends adjusting breaker point gap with new points to 0.016, or adjust to 0.0165 if both points and crankshaft are new. Condenser capacity should test 0.16-0.20 mfd. Note that the breaker point and condenser retain the felt dust seal (12—Fig. HL104) and washer (13). Adjust armature to flywheel (magneto rotor) air gap to 0.004-0.008.

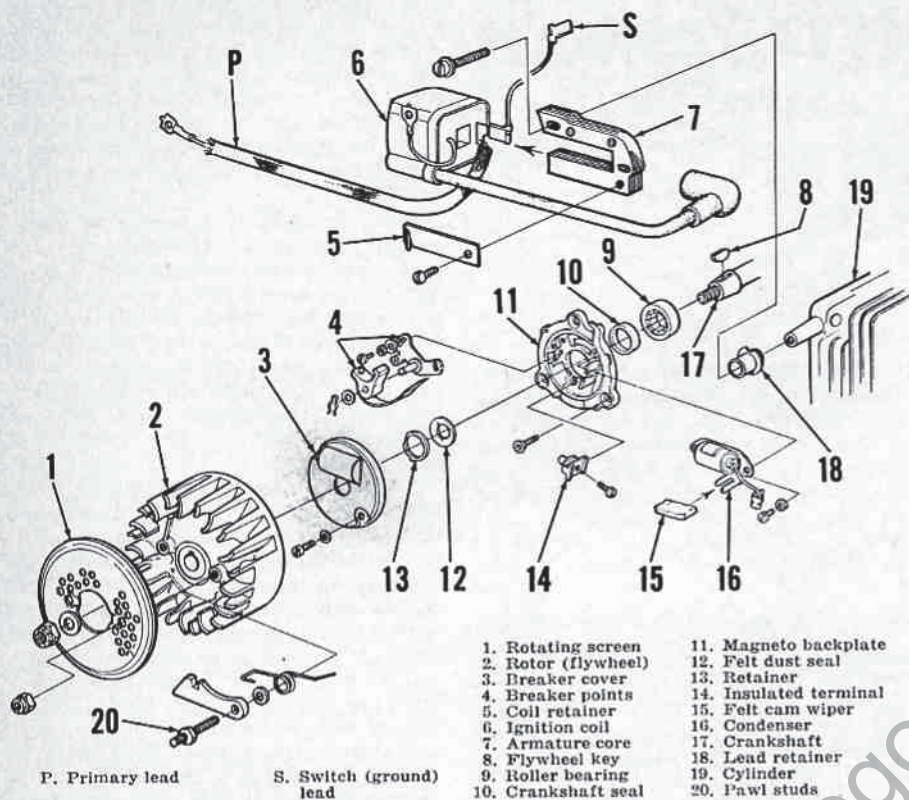

Fig. HL104—Exploded view of conventional flywheel magneto used on models XL-101, XL-102, XL-102 automatic, XL-103 and XL-103E. Felt dust seal retainer (13) is held in place by condenser bracket and breaker point base. Refer also to Figs. HL105 and HL106.

On early production, magneto back plate was retained to crankcase by three flat head screws in countersunk mounting holes. On later models, the mounting holes were changed and wafer head "Pozidriv" type screws were used. A third production change, the back plate and crankcase were changed to use five back plate retaining screws instead of the three used previously. Although flat head screws must be used with early back plate having countersunk holes and wafer head screws be used with the later type back plates, back plates and crankcases are interchangeable. When installing back plate to crankcase with one unit having five holes and the other three holes, use the original three retaining screw locations. Late type gasket with five screw holes can be used on all applications. Tighten back plate retaining screws evenly in stages to a final torque of 80-90 inch-pounds.

MAGNETO (Model XL-104). Refer to Fig. HL107 for exploded view of the solid state breakerless Wico flywheel magneto used on models XL-104 and XL-104E.

NOTE: Latest production model XL-104 saws are equipped with a capacitor discharge magneto; refer to page 86 for further information.

To check the magneto, connect a test spark plug to high tension lead, turn ignition switch on and crank engine. If there is no spark, remove fan housing and inspect flywheel and wiring for physical damage. If no defects are noted, disconnect coil primary lead at switch box and check coil with Graham or Merc-O-Tronic tester according to tester manufacturer's procedure.

Test specifications for each tester are given in Homelite IGNITION SYSTEM SPECIFICATIONS on page 28.

If coil tests OK, disconnect the condenser (black) lead from switch box and test condenser by attaching one tester lead to black lead and other tester lead to engine ground. Check the condenser for short, series resistance and capacity; condenser capacity should test 0.13-0.15 mfd.

To check trigger coil, disconnect trigger coil (white) lead from switch box and connect one lead of ohmmeter to the trigger coil lead and other ohmmeter lead to engine ground. The ohmmeter reading should be either between 25 to 80 ohms or between 80 to 110 ohms. Reverse the ohmmeter leads; the reading should then be alternate to the first ohmmeter reading. Thus, if the first reading was between 20 to 80 ohms, the second reading should be between 80 to 110 ohms, or vice versa.

To check trigger switch, disconnect all wires from the switch. Then, connect one lead of ohmmeter to switch box "P" terminal (see Fig. HL107) and other ohmmeter lead to switch box ground terminal (retaining strap screw eye). Ohmmeter reading should be either between 5 to 25 ohms or between 1 megohm to infinity. Reverse the ohmmeter leads and alternate reading should be obtained. Thus, if first reading was between 5 to 25 ohms, second reading should be between 1 megohm to infinity, or vice versa.

Renew any component not checking within specified test values and reconnect wiring according to connection code shown in Fig. HL107. Note: Although not necessary to re-

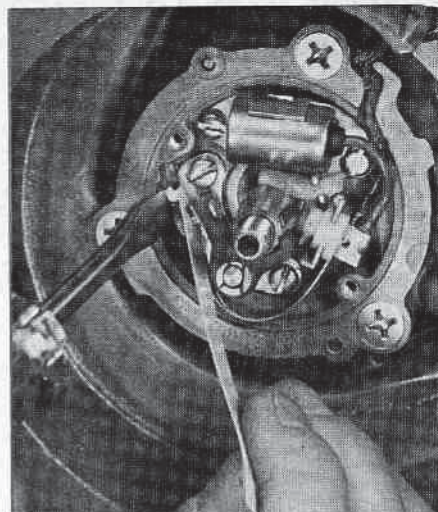

Fig. HL105—View showing magneto backplate, condenser and breaker point assembly. A pry slot is provided to facilitate breaker point adjustment. Late back plate has five retaining screws.

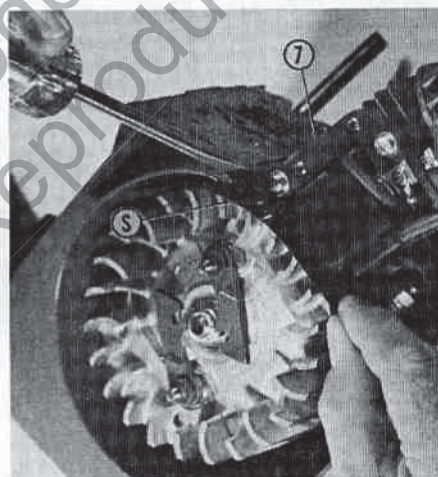

Fig. HL106—Adjusting air gap between flywheel and armature (7) using plastic shim (S). Air gap should be 0.004-0.008.

move flywheel to check or test magneto components, the flywheel must be removed to renew trigger coil and/or condenser. Adjust armature air gap as outlined in preceding paragraph for conventional magneto used on other models.

On early models, trigger coil (magneto back plate) was retained to crankcase with three screws. Later production models have five back plate retaining screws. When installing late type back plate or crankcase with five screw holes to crankcase or back plate with three screw holes, use only the original three mounting screw positions. Tighten the wafer head screws evenly in stages to a final torque of 80-90 inch-pounds. Use only a #2 "Pozidriv" screwdriver bit (Homelite tool No. 24304) to remove or tighten back plate screws.

LUBRICATION. Engine is lubricated by oil mixed with the fuel. Mix ½-pint of Homelite oil or SAE 30 non-detergent motor oil with each gallon of regular gasoline; mix fuel and oil in a separate container.

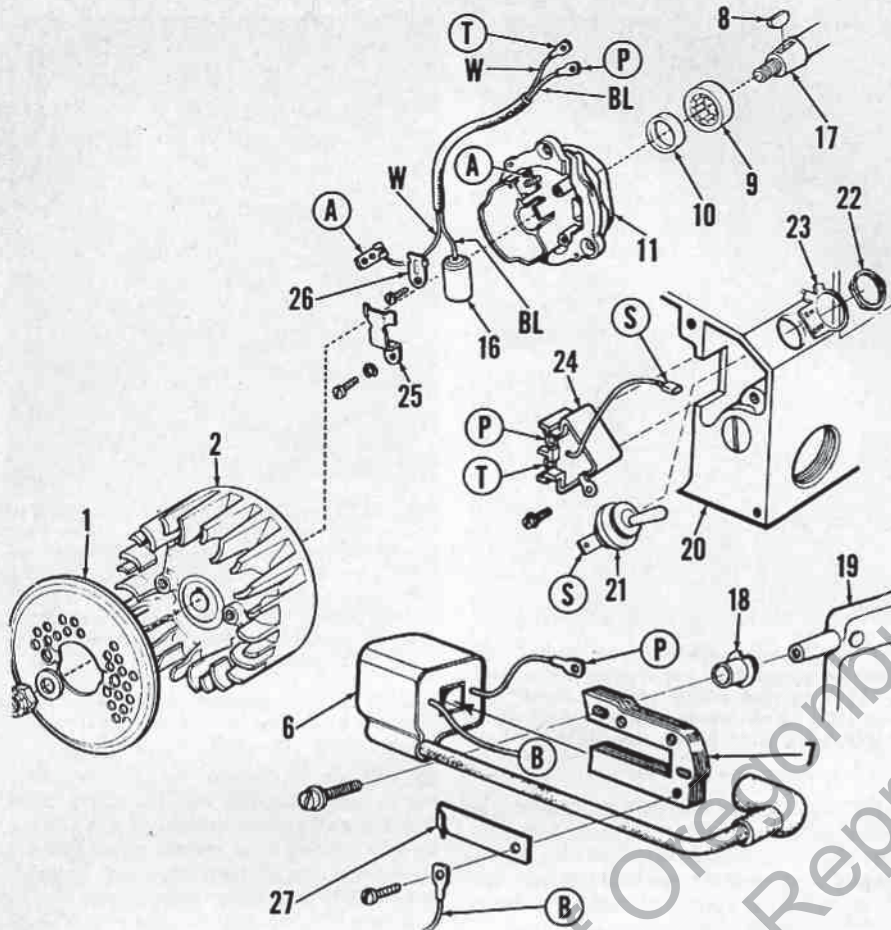

Fig. HL107—Exploded view of the breakerless solid state Wico magneto used on model XL-104 prior to serial No. 2805890. Wiring connections are identified by circled letter; thus, connect wire clip (A) to connection (A) on trigger coil, etc. White wire (W) connects trigger coil to terminal (T) on trigger switch (24). Refer to Fig. HL107A for wiring diagram on model XL-104 above serial No. 2805889.

- | | | | |
|------------------------------|------------------------------|--------------------------------------|---------------------|
| A. Trigger coil connection | T. Trigger switch connection | 9. Roller main bearing | 19. Cylinder |
| B. Coil ground lead | W. White lead | 10. Crankshaft seal | 20. Throttle handle |
| BL. Black (condenser) lead | 1. Rotating screen | 11. Magneto backplate (trigger coil) | 21. Ignition switch |
| P. Trigger switch connection | 2. Magneto rotor (flywheel) | 16. Condenser | 22. Nut |
| S. Switch connection | 6. Ignition coil | 17. Crankshaft | 23. "ON-OFF" plate |
| | 7. Armature | 18. Condenser lead retainer | 24. Trigger switch |
| | 8. Flywheel key | | 25. Condenser clamp |
| | | | 26. Lead retainer |
| | | | 27. Coil retainer |

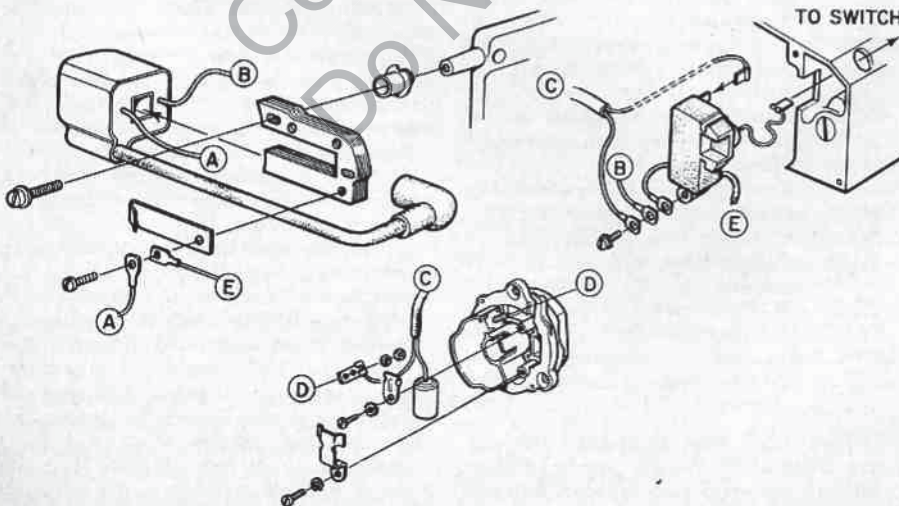

Fig. HL107A—View showing late type solid state magneto. Letters indicate wiring connections. Magneto can be identified by red colored trigger switch whereas early trigger switch (24—Fig. HL107) is natural color. The back plate (trigger coil), rotor, trigger switch, condenser and throttle handle are not interchangeable with early type magneto components shown in Fig. HL107.

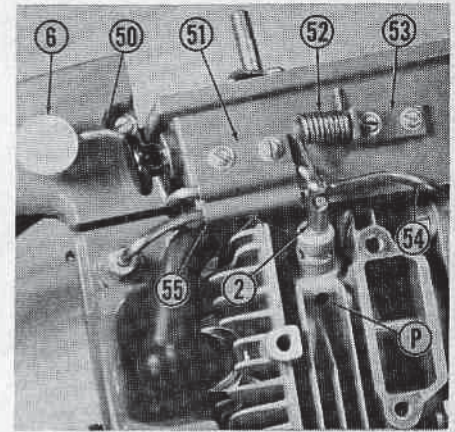

Fig. HL108—View with muffer assembly removed to show compression relief mechanism. Depressing throttle latch button (6) actuates lever (50) lifting compression relief plunger (2). Engine compression is then relieved through port (P).

- | | |
|----------------------------|--------------------|
| 1. Compression relief port | 50. Release lever |
| 2. Relief valve plunger | 51. Lever bracket |
| 6. Throttle latch button | 52. Valve spring |
| | 53. Spring bracket |
| | 54. Chain oil tube |
| | 55. Tube clamp |

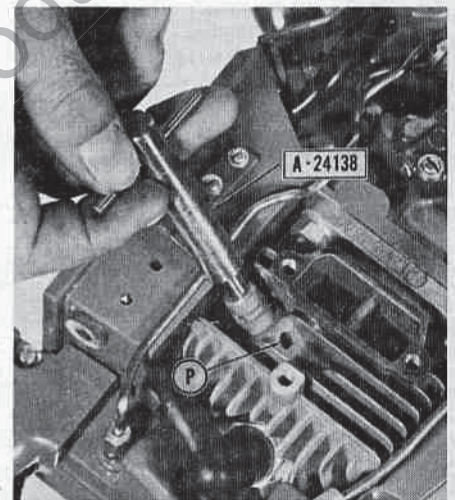

Fig. HL109—Cleaning compression relief valve seat using Homelite tool No. A-24138. Hold the engine with relief port (P) down so that carbon scraped from seat will fall out.

Fill chain oiler reservoir with Homelite Bar and Chain oil or with light motor oil (not over SAE 30). In cold weather, thin oil with kerosene until it flows freely.

The clutch needle roller bearing should be cleaned and relubricated after each 100 hours of operation. A high temperature grease such as Aero Shell #L-14, Aero Shell #5, Texaco Unitemp #500 or Humble (Esso) Nebula EP1 should be used.

CARBON. Muffler and cylinder exhaust ports should be cleaned periodically to prevent loss of power due to carbon build up. Remove muffler and scrape free of carbon. With muffler removed, turn engine so that piston is a top dead center and carefully remove carbon from exhaust ports with a wooden scraper. Be careful not to damage

chamfered edges of exhaust ports or to scratch piston. Do not run engine with muffler removed.

CLEAN COMPRESSION RELIEF VALVE.

While muffler is removed to clean carbon from the muffler and exhaust ports, proceed as follows to clean the compression relief valve:

Remove the two bolts retaining compression relief lever bracket (51—Fig. HL108) and oil tube clamp (55) to air box and remove the compression relief lever (50) and throttle latch (6). Using pliers, carefully lift end of spring (52) from notch in end of valve plunger (2) and ease spring down against oil tube. CAUTION: Do not allow spring to snap against the oil tube as this will dent the tube causing a restriction. Remove the valve plunger (3—Fig. HL113) (early models), then turn saw over and allow the steel ball (2) to drop out. On late models, remove the pin (38) and valve (37).

Turn crankshaft so that piston is at bottom dead center, position engine with valve bore down so that scrapings will fall out and clean the valve seat using Homelite tool No. A-24138 as shown in Fig. HL109.

Reinstall valve and lift spring back into notch in plunger. Note: Late type valve (37) and pin (38) can be installed in early models in place of plunger (3) and ball (2); however, ball must be used with plunger (3). Reinstall actuating lever and throttle latch as a unit, then reinstall oil tube and lever clamps.

REPAIRS

TIGHTENING TORQUE VALUES. Tightening torque values for XL-101/XL104E series units are as follows:

NOTE: All values are in inch-pounds and minimum torque value is given; to find maximum torque value, add 20% to value given.

| | |
|---------------------------------|-------|
| 6/32 Compression release lever | 20 |
| 6/32 Compression release spring | 20 |
| 6/32 Point dust cover | 15 |
| 8/32 Automatic chain oiler | 40 |
| 8/32 Intake manifold | 40(1) |
| 8/32 Intake manifold | 20(2) |
| 8/32 Throttle handle cover | 40 |
| 8/32 Starter (fan) housing | 40 |
| 8/32 Coil assembly | 20 |
| 8/36 Connecting rod | 55 |
| 10/32 Muffler cap | 30 |
| 10/32 Handle bar bracket | 50 |
| 10/32 Handle bar | 50 |
| 10/32 Screen to rotor | 50 |
| 10/32 Pulley to starter housing | 50 |
| 10/32 Carburetor to manifold | 50(1) |
| 10/32 Carburetor to manifold | 25(2) |
| 10/32 Bearing retainer | 55 |
| 12/24 Back plate | 80 |
| 12/24 Carburetor chamber | 80 |
| 12/24 Pawl studs to rotor | 80 |
| 12/24 Air filter bracket | 80 |
| 12/24 Muffler to cylinder | 80 |
| 1/4-28 Cylinder nuts | 100 |
| 5/16-24 Rotor nut | 150 |
| Clutch plate to crankshaft | 180 |
| 14MM Spark plug | 250 |

(1) Early type intake manifold using spacer and two gaskets between manifold and carburetor.

(2) Late type intake manifold using single gasket (no spacer) between manifold and carburetor.

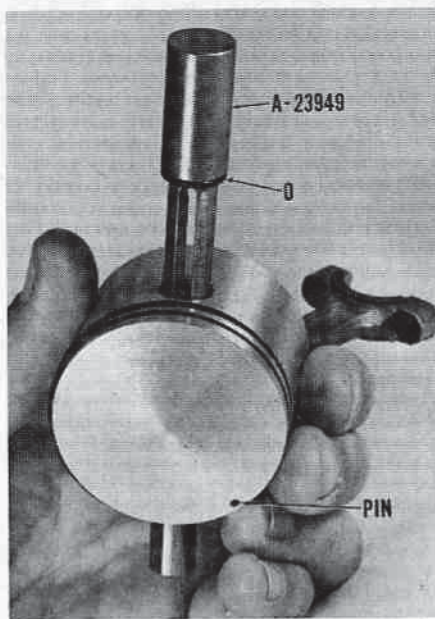

Fig. HL110—On models with Spirol pin retaining piston pin, use Homelite tool No. A-23949 to push piston pin out. Note "O" ring (O) which protects piston from damage by tool. Note piston ring retaining pin.

RECOMMENDED SERVICE TOOLS. Tools available from Homelite are as follows:

| Tool No. | Description |
|-----------|--|
| 23756 | Connecting rod bearing tool |
| A-24051 | Main bearing (drive end) & crankshaft jackscrew; also requires: |
| 23136-1 | Sleeve |
| 22820-5 | Collar |
| 24076 | Seal protector |
| 24006-1 | Alignment plate |
| 23972 | Crankshaft seal installer (drive end w/crankshaft installed) |
| 24054 | Crankshaft seal installer (drive end w/crankshaft removed) |
| A-24057 | Main bearing remover (backplate end) |
| 23846-2 | Anvil (for use w/A-24057) |
| 24055 | Main bearing installer (backplate end); seal remover & installer (backplate) |
| 24053 | Seal protector sleeve (XL-101) |
| 24076 | Seal protector sleeve (Except XL-101) |
| 23759 | Seal protector (backplate) |
| 22828 | Piston pin snap ring pliers |
| A-23949 | Piston pin remover |
| A-23960 | Rotor (flywheel) holder & remover |
| A-24060 | Clutch spanner wrench (Early) |
| A-23934 | Clutch spanner wrench (Late) |
| A-24138 | Compression relief valve seat reamer |
| 24304 | #2 "Pozidriv" bit |
| 24230 | #3 "Pozidriv" bit |
| A-23841-A | Bar stud insert wrench |
| 24173 | Carburetor check valve installer |

CONNECTING ROD. Connecting rod and piston assembly can be removed from crankshaft after removing cylinder. Be careful to remove all of the 31 loose needle rollers when detaching rod from crankshaft.

Renew connecting rod if bent or twisted, or if crankpin bearing surface is scored, burned or excessively worn. The needle

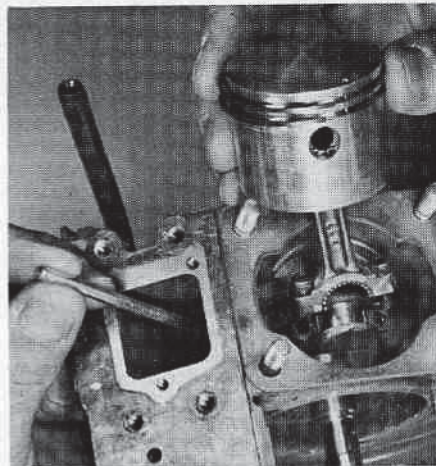

Fig. HL111—View showing reassembly of connecting rod to crankpin. Note that needle rollers are stuck to rod and cap with grease. Rod cap is held in position with Allen wrench. Be sure that match marks on rod and cap are aligned, and that intake side of piston is towards flywheel end of crankshaft as shown.

roller piston pin bearing can be renewed by pressing old bearing out and new bearing in using Homelite tool No. 23756. Note: If substitute bearing installation tool is used, be sure bearing cage extends equal distance from each side of connecting rod. Press on lettered end of bearing cage only.

Renew the crankpin needle rollers as a set if any roller has flat spots or is scored or worn. If reusing needle rollers, use grease to stick 16 rollers in rod cap and 15 rollers in connecting rod; refer to Fig. HL111 for assembly of rod and piston unit to crankshaft. New needle rollers are supplied in a strip of 31 rollers; wrap the waxed strip around crankpin; then assemble rod and piston unit to crankshaft as in Fig. HL111. Be sure that match marks on rod and cap are aligned and secure rod to cap with new socket head screws.

PISTON, PIN AND RINGS. The piston is fitted with two pinned compression rings. Renew piston if scored, cracked or excessively worn. If ring side clearance in top ring groove exceeds 0.004 when measured with new ring, piston should be renewed.

Recommended piston ring end gap is 0.070-0.080; maximum allowable ring end gap is 0.085. Desired ring side clearance in groove is 0.002-0.003.

Piston, pin and rings are available in standard size only. Piston and pin are not available separately.

Early type pin is retained in piston by a Waldes Truarc snap ring at intake side of piston and by a Spirol pin at exhaust side. Closed end of piston pin must be towards Spirol pin. To remove piston from connecting rod, remove snap ring using Truarc snap ring pliers (Homelite tool No. 22828 or equivalent) and push pin out using Homelite tool No. A-23949 as shown in Fig. HL110.

On late production pistons, pin is retained by a plain square end snap ring at exhaust side and by a Waldes Truarc snap ring

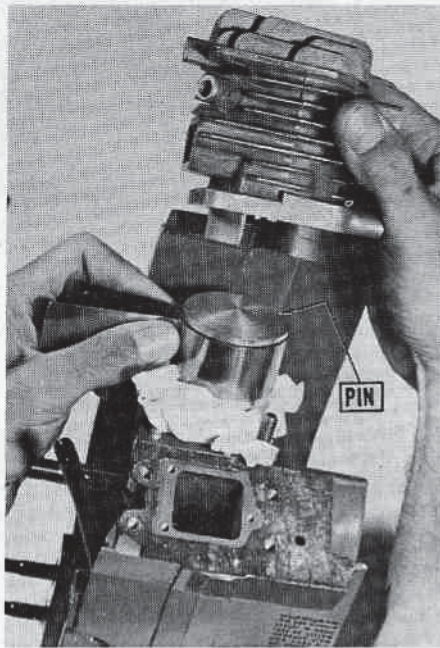

Fig. HL112—View showing cylinder being installed over piston. Piston is held upright by rags stuffed around rod. Make final check to be sure piston ring pin is towards intake side of cylinder as shown.

at intake side. Do not remove the plain square end snap ring. To remove piston pin, remove the Waldes Truarc snap ring, then insert a $\frac{1}{8}$ -inch dia. rod through the plain snap ring and drive pin from piston.

When reassembling piston to connecting rod, push piston pin with a $\frac{1}{8}$ -inch diameter rod inserted in open end of pin. Install snap ring at open end of pin with sharp edge of ring out. Rotate snap ring to be sure it is seated in groove, then turn snap ring gap towards closed end of piston.

CYLINDER. The cylinder can be unbolted and removed from crankcase and piston after removing fan housing and starter assembly and the throttle handle, air box and chain oil tank assembly. Be careful not to let piston hit against crankcase as cylinder is removed.

NOTE: If renewing cylinder, measure pilot diameter in crankcase. Early model crankcase pilot diameter was $1\frac{1}{8}$ inch, whereas late models have 2 inch pilot diameter. Be sure to obtain correct size cylinder and gasket.

The cylinder bore is chrome plated. Renew cylinder if chrome plating has worn away exposing the softer base metal. Except on Model XL-101 or XL-102 Automatic, refer also to COMPRESSION RELEASE paragraph.

CRANKSHAFT, BEARINGS AND SEALS. Crankshaft is supported at drive end by a ball bearing in crankcase and at flywheel end by a roller bearing in magneto backplate. Crankshaft end play is controlled by the ball bearing which is retained on crankshaft by a snap ring and in crankcase by two screws and special washers.

To remove crankshaft, first remove the clutch assembly, automatic chain oiler pump

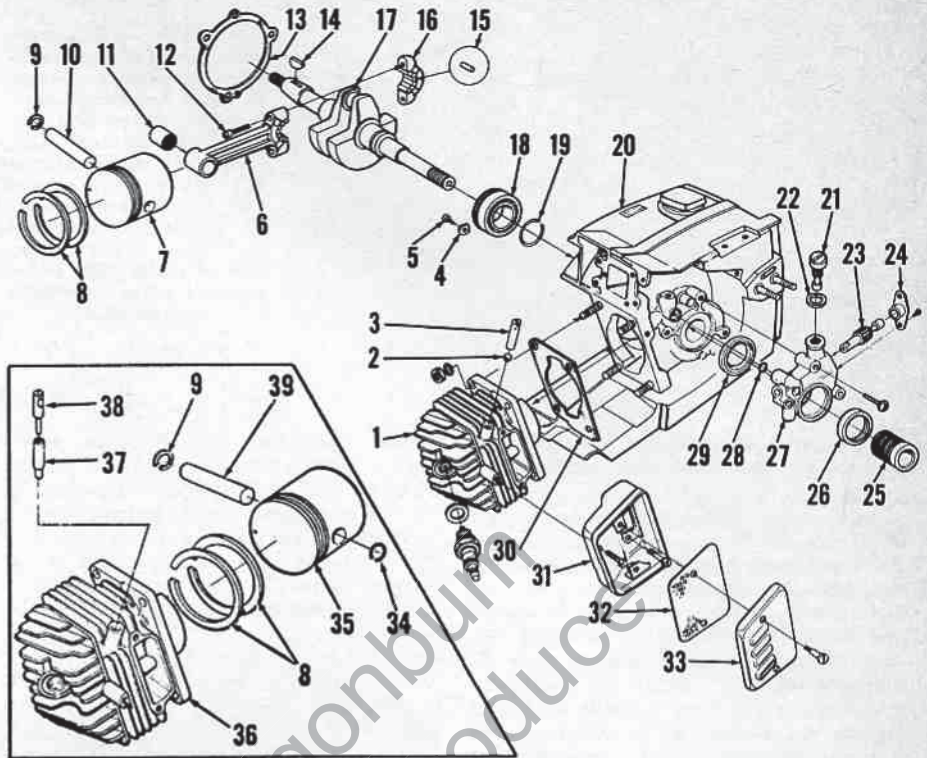

Fig. HL113—Exploded view of typical XL-Series engine assembly; all models are of similar construction except that Model XL-101 does not have compression relief valve and Models XL-101 and XL-102 do not have the automatic chain oiler pump. Inset shows late type compression relief valve and piston pin retained with two snap rings instead of Spirol pin and one snap ring. Refer to Fig. HL104 or to Fig. HL107 for flywheel end main bearing which is supported in magneto backplate.

- | | | | |
|-------------------------|----------------------|---------------------------------|--------------------------|
| 1. Cylinder | 10. Piston pin | 20. Crankcase & fuel tank assy. | 29. Crankshaft seal |
| 2. Relief valve | 11. Needle bearing | 21. Cam screw | 30. Gasket |
| 3. Valve plunger | 12. Rod cap screws | 22. Gasket | 31. Muffler body |
| 4. Special washers (2) | 13. Backplate gasket | 23. Pump plunger & gear | 32. Baffle |
| 5. Retaining screws (2) | 14. Flywheel key | 24. Flange bearing | 33. Muffler cover & gear |
| 6. Connecting rod | 15. Needle rollers | 25. Worm gear | 34. Snap ring |
| 7. Piston | 16. Rod cap | 26. Felt seal | 35. Piston |
| 8. Rings | 17. Crankshaft | 27. Pump body | 36. Cylinder |
| 9. Snap ring | 18. Ball bearing | 28. "O" ring | 37. Relief valve |
| | 19. Snap ring | | 38. Valve plunger |
| | | | 39. Piston pin |

on models so equipped, the fan housing and starter assembly, magneto rotor, the throttle handle, air box and chain oiler tank assembly, cylinder, and the connecting rod and piston. Remove the screws retaining magneto backplate to crankcase and carefully pry backplate from crankcase and the two locating dowel pins. Working through magneto backplate opening, remove the two screws and special washers retaining ball bearing in crankcase, then press crankshaft and bearing assembly from crankcase.

An expandable type bearing remover (Homelite tool No. A-24507) is available for removing roller bearing from backplate. Insert tool through bearing from inner side of backplate taking care to push tool through bearing only far enough that collets will engage outer side of rollers. Tighten the expander screw of tool, then place backplate on suitable support such as Homelite tool No. 23846-2 and drive bearing from backplate. Remove old crankshaft seal, lubricate new seal and install with lip to inner side of backplate; large stepped end of Homelite tool No. 24055 may be used to install seal. Lubricate outer race of new bearing and bore in backplate, then place bearing on small stepped end of Homelite tool No. 24055 or use other suitable tool

and press bearing into backplate. **CAUTION:** Due to tight press fit, installing bearing dry may cause distortion and early bearing failure.

If necessary, remove the retaining snap ring and press crankshaft from ball bearing. New bearing can be installed on crankshaft with bearing collar (Homelite tool No. 22820-5) and sleeve (23136-1) using jackscrew (A-24051) threaded onto clutch end of crankshaft. Be sure to lubricate bearing and shaft before pushing bearing onto shaft. If special tools are not available, support crankshaft under crankpin throw and use suitable sleeve to press bearing into place. Note: Press against bearing inner race only. Be sure snap ring groove in outer race is towards crankpin (see G—Fig. HL114). Install snap ring on crankshaft with sharp edge away from bearing.

Drive old seal out towards inside of crankcase using long end of Homelite tool No. 24054 or other suitable driver. Install new seal in crankcase using short end of tool No. 24054; if using substitute seal installation tool, outer face of seal should be $\frac{1}{16}$ -inch below flush with crankcase. Note: Be sure lip of seal is towards inside of crankcase. If desired, new seal can be installed after installing crankshaft and bear-

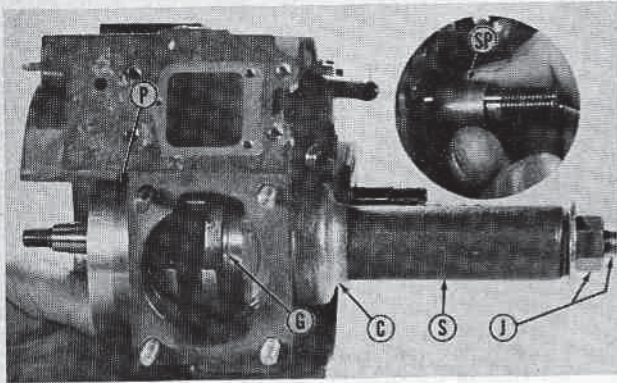

Fig. HL114 — Alignment plate (P) fits onto magneto backplate dowel pins to guide crankshaft as it is being pulled into position with collar (C), sleeve (S) and jackscrew (J). Note that groove (G) in main bearing outer race is next to crankpin throw. Inset shows seal protector (SP) being removed after crankshaft is in position.

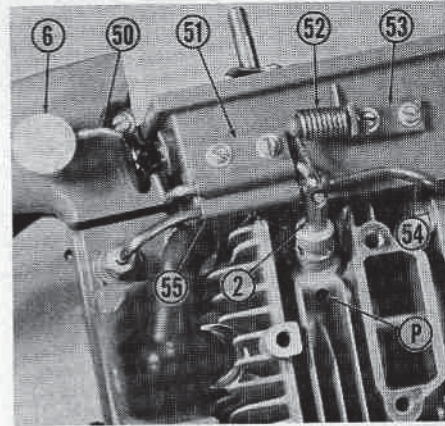

Fig. HL115—View showing compression relief mechanism; all models except XL-101 and XL-102 Automatic are so equipped.

ing assembly; Homelite tool No. 23972 can be used to install seal with crankshaft installed.

Refer to Fig. HL114 for recommended crankshaft installation procedure. Be sure to lubricate both bearing and bore in crankcase before installing crankshaft and bearing assembly. Due to tight press fit, installing bearing dry may cause distortion and early bearing failure. Alignment plate (P) (Homelite tool No. 24006-1) fits onto magneto backplate dowels to guide shaft and bearing as the bearing is being pressed into crankcase. Insert shows removing seal protector (SP) (Homelite tool No. 24076) after crankshaft is installed. Note position of retaining groove (G) in bearing outer race. Use two new screws and special washers to secure bearing in crankcase. Refer to appropriate MAGNETO paragraph for installation of back plate to crankcase.

COMPRESSION RELIEF VALVE. Except for models XL-101 and XL-102 Automatic, all models are equipped with compression relief valve for easier cranking. When throttle lock (6—Fig. HL115) is pushed in, lever (50) lifts plunger (2) against spring (52) pressure. Then, when engine is cranked, compression is partly relieved through port (P). Squeezing throttle trigger after engine starts releases throttle lock allowing spring to close valve.

Service of the compression relief valve usually consists of cleaning the valve seat as the port may gradually fill with carbon while the engine is running with compression relief valve open. Refer to MAINTENANCE paragraph for seat cleaning procedure. Early models used steel ball (2—Fig. HL113) and plunger (3) to hold ball on seat. Late valve (37) and pin (38) are available as assembly only and may be used to renew early type plunger and steel ball.

When overhauling engine, the cylinder should be inspected for any damage to the compression relief valve port and valve seat. Renew cylinder if there is damage to port or seat that cannot be remedied by cleaning with Homelite tool No. A24138 as shown in Fig. HL109.

CRANKCASE, FUEL TANK AND BACK PLATE. On early models, crankcase and fuel tank were an integral epoxied unit. On later models, fuel tank cover is sealed to crankcase with a gasket and is retained with screws. Several different types of screws have been used, the latest type being "Poixdriv" screws which are used as

service replacement for all earlier types. Use a No. 2 "Poixdriv" screwdriver bit (Homelite tool No. 24304 or equivalent) to remove and install cover retaining screws.

Cylinder pilot diameter in crankcase is $1\frac{1}{8}$ inches on early models and 2 inches on late models. A new crankcase with 2 inch pilot diameter can be installed with

- | | |
|---------------------------|--------------------|
| P. Relief port | 51. Lever bracket |
| 2. Valve plunger | 52. Valve spring |
| 6. Throttle trigger latch | 53. Spring bracket |
| 50. Valve lever | 54. Oiler tube |
| | 55. Tube clamp |

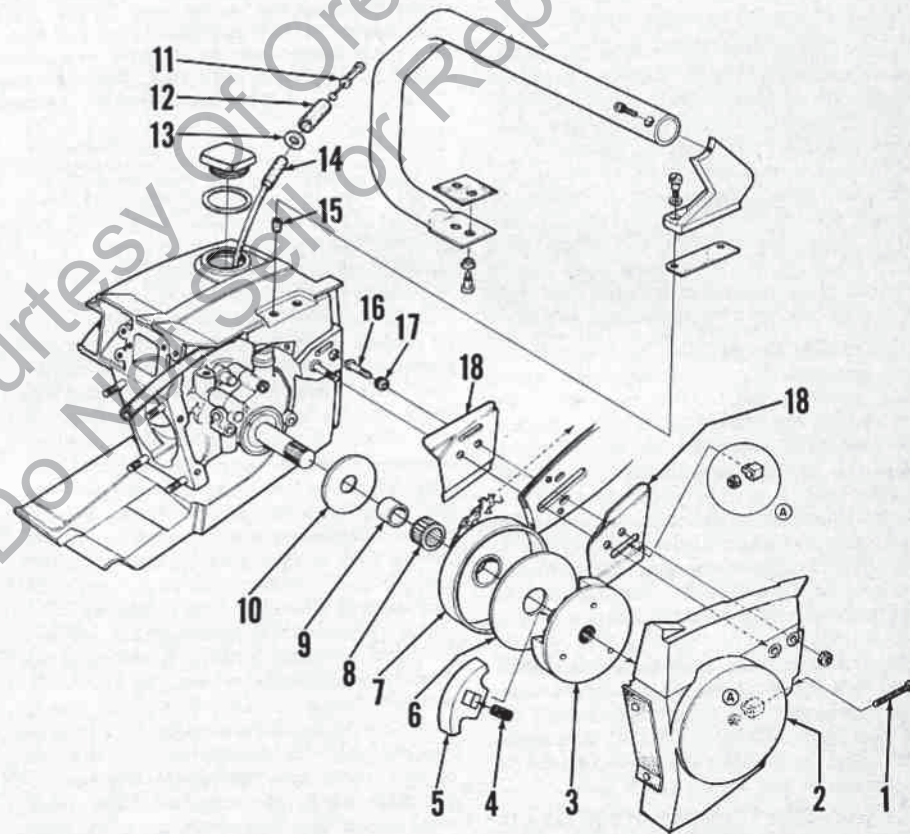

Fig. HL116—Exploded view showing clutch cover and chain tension adjustment, clutch and fuel tank (engine crankcase and fuel tank assembly). Clutch plate (3) is threaded to crankshaft (L.H. threads). On model XL-102 only, a spacer (not shown) is used between washer (10) and shoulder on crankshaft. On late models, fuel tank cover is a separate part; refer to Fig. HL116A.

- | | | | |
|--------------------|---------------------------|------------------|--------------------|
| 1. Adjusting screw | 5. Shoes | 9. Bearing race | 14. Flexible tube |
| 2. Clutch cover | 6. Large washer | 10. Small washer | 15. Thread insert |
| 3. Clutch plate | 7. Clutch drum & sprocket | 11. Fuel pickup | 16. Bar studs |
| 4. Springs | 8. Needle bearing | 12. Filter | 17. Stud retainers |
| | | 13. Washer | 18. Guide plates |

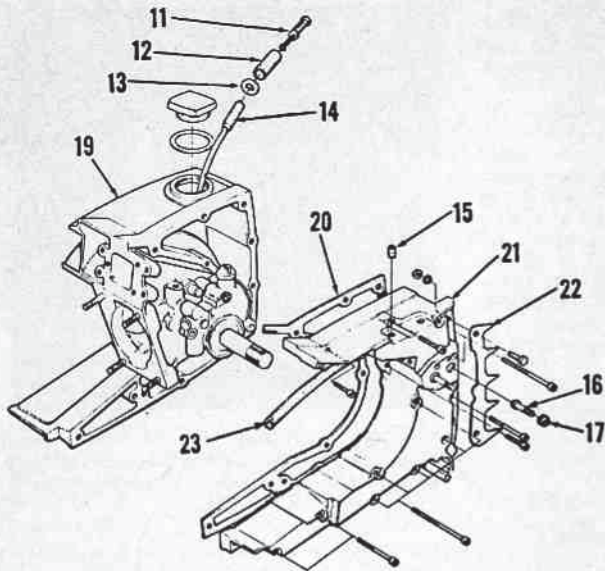

Fig. HL116A—Late type fuel tank (19) and cover (21) are separate parts sealed with a gasket (20) whereas early tank and cover was a single epoxied unit. Note flexible hose (14), pickup (11) and filter (12) used instead of felt wick as on early models. Guide bar studs (16) are retained by threaded retainers (17).

- 11. Pickup
- 12. Filter
- 13. Washer
- 14. Flexible hose
- 15. Threaded insert
- 16. Guide bar studs
- 17. Stud retainers
- 19. Fuel tank & crankcase
- 20. Gasket
- 21. Fuel tank cover
- 22. Bumper spike
- 23. Fuel line

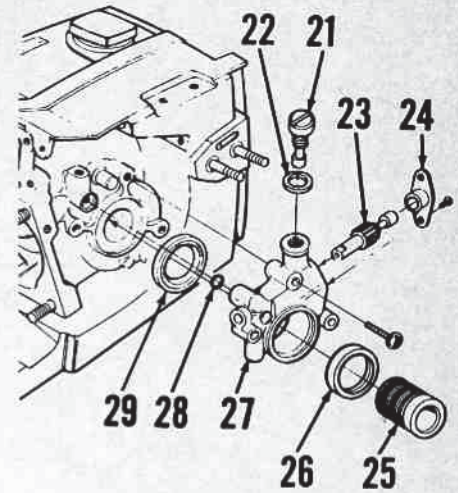

Fig. HL119—Exploded view of automatic chain oiler pump assembly used on models XL-102 Automatic, XL-103 and XL-104. Worm gear (25) is driven by engine crankshaft.

- 21. Cam screw
- 22. Gasket
- 23. Plunger & gear
- 24. Flange bearing
- 25. Worm gear
- 26. Felt seal
- 27. Pump body
- 28. "O" ring
- 29. Crankshaft seal

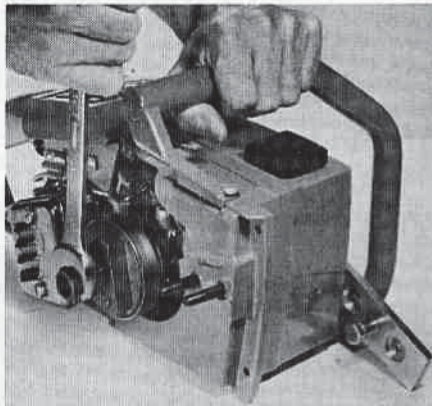

Fig. HL117—Turn clutch rotor clockwise to unscrew from crankshaft (L.H. threads). Spanner wrench is Homelite tool No. A24-060 for early 2 3/4 inch clutch or A-23934 for late 3 1/16 inch clutch. Flywheel (rotor) holder is Homelite tool No. A-23960.

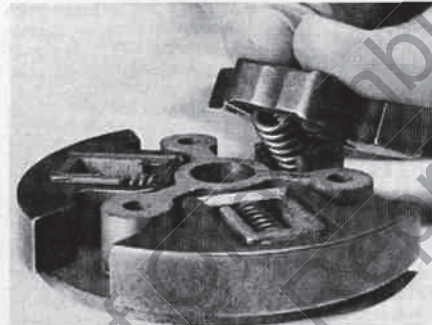

Fig. HL118—To install clutch shoes, hook shoe and spring on clutch plate as shown, then push shoe down into place. Early type clutch is shown.

early type cylinder having a 1 1/8 inch pilot diameter; use correct gasket with cylinder.

Early magneto back plate was retained to crankcase with three flat head screws fitting into countersunk holes in back plate. Later back plates were changed to use three wafer head retaining screws. Latest crankcase and back plate have five screw holes for the wafer head type screws. Gasket with five bolt holes is used for all models. Use a No. 3 "Phillips" screwdriver bit to remove and install early type flat head (countersunk) screws, or a No. 2 "Pozi-driv" screwdriver bit for the later type wafer head screws. Tighten retaining screws evenly and in stages to a final torque of 80-90 inch-pounds when installing magneto back plate.

PYRAMID REED VALVE. All models are equipped with a "Delrin" plastic pyramid valve seat and stainless steel valve reeds. Pyramid seat, reeds and retainer can be removed after removing carburetor and

adapter elbow. The reeds fit on pins molded into the pyramid seat and can be lifted from the seat after removing seat and valve assembly. Inspect the pyramid seat and reed retainer for distortion and/or deterioration. Inspect reeds for cracks or being bent or broken.

To reinstall, proceed as follows: Fit the reed retainer carefully into crankcase. Stick the reeds to the pyramid seat with light oil, then push the seat and reed assembly into the retainer. Homelite recommends that the reed valve assembly and reed retainer always be installed separately. Install carburetor adapter with new gasket using the three special shouldered screws.

CLUTCH. Refer to Fig. HL116 for exploded view of shoe type clutch used on early models. Late type clutch has "full radius" shoes and is 3 1/8 diameter whereas early clutch is 2 3/4 inch diameter. The clutch rotor (plate) (3) is threaded to the crankshaft and can be removed as shown in Fig. HL117; note that L.H. threads are used.

The needle roller bearing (8—Fig. HL 116) should be removed, cleaned and lubricated after each 100 hours of operation. A high temperature grease such as Aero Shell #L-14, Aero Shell #5, Texaco Unitemp

#500 or Humble (Esso) Nebula EP1 should be used.

If clutch slips with engine running at high speed under load, check the clutch shoes for excessive wear. If chain continues to turn with engine running at idle speed (below normal clutch engagement speed of 3000 RPM), check for broken, weak, distorted or improperly installed clutch springs. If early type (2 3/4 inch diameter) clutch components are not suitable for further service, renew with late type (3 1/8 diameter) clutch unit.

To disassemble clutch plate and shoe assembly, pry shoes from plate with screwdriver. To install clutch shoes and springs, refer to Fig. HL118. When installing clutch plate and shoe assembly on crankshaft, tighten to a torque of 180 inch-pounds.

AUTOMATIC CHAIN OILER PUMP. All models except XL-101 and XL102 are equipped with an automatic chain oiler pump which is located behind the clutch and chain sprocket. Refer to exploded view in Fig. HL119. Pump body (27) is attached to crankcase and worm gear (25) is driven by crankshaft.

To service pump, unscrew the clutch plate assembly as shown in Fig. HL117 and remove clutch drum and bearing. The automatic chain oiler pump can then be removed from engine crankcase after disconnecting the oil lines.

Worm gear (25—Fig. HL119) can be removed from pump body. To remove pump plunger (23) for inspection, first remove flange bearing (24) and cam screw (21). Pump body and plunger are serviced as a matched assembly only. Flange bearing retaining screws are available separately. Pry felt dust seal (26) from pump body and install new seal using suitable driver. Install new gasket (22) on cam screw and use

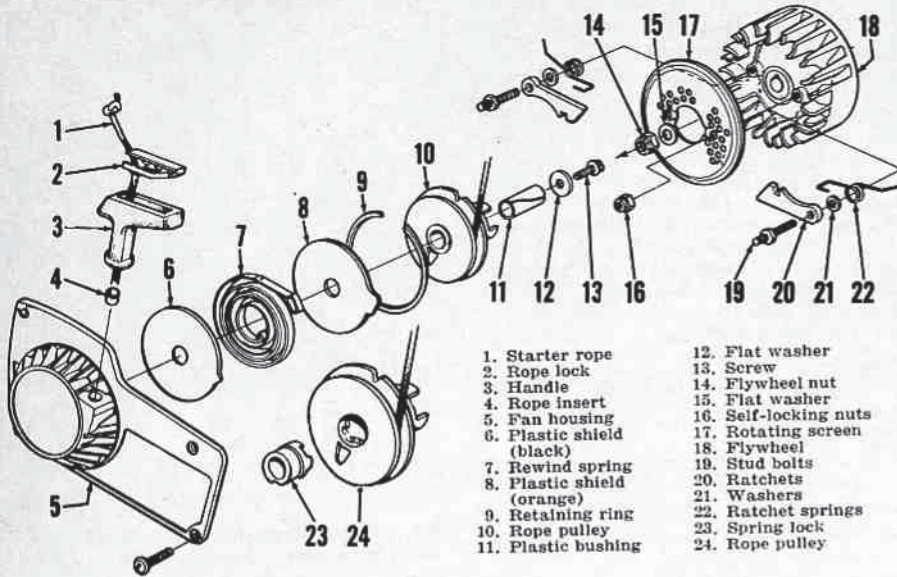

Fig. HL120—Exploded view of typical ratchet type rewind starter used on all models. Refer also to Figs. HL121 and 122. Late type rope pulley (24) and separate spring lock (23) can be installed if necessary to renew early type pulley (10) with integral lock. On models XL-103E and XL-104E, a stationary screen is attached to outside of housing (5) and rotating screen (17) is not used.

new "O" ring (28) when reassembling and reinstalling pump. Tighten pump retaining screws evenly to a minimum torque of 40 inch pounds.

REWIND STARTER. For exploded view of starter, refer to Fig. HL120. To disassemble starter, refer to Fig. HL121 and proceed as follows: If starter spring remains under tension, pull the starter rope out about two turns of pulley, hold pulley from turning and pull loop of rope out past notch in pulley. Allow the starter spring to completely unwind, then remove screw (13) and disassemble unit. Be careful when removing spring; a rapidly uncolling starter spring could cause serious injury.

Refer to exploded view in Fig. HL120 and to Fig. HL122 for reassembly guide. It is recommended that the spring be reinstalled dry (without oil or grease) and the starter post and plastic sleeve be lubricated with light oil only. Install black plastic spring shield, spring (as shown in Fig. HL122) and the orange plastic shield on top of spring.

If inner loop of spring is not then visible through hole in orange plastic shield, bend inner loop in towards starter post. Install retaining ring (9—Fig. HL120). Late type pulley (24) and separate spring lock (23) are used to renew early type pulley (10) with integral spring lock.

If necessary to install new rope, insert end through pulley and tie knot as shown at (K—Fig. HL121). Heat end of rope to secure knot, then insert other end through rope guide in fan housing and secure in handle. Wind cord all the way onto pulley, then fit pulley and plastic sleeve onto starter post. Pull rope out far enough to be sure pulley engages spring, then allow spring to rewind. Install pulley retaining washer and screw and tighten screw to minimum torque of 50 inch-pounds. Pull cord out about two feet so that notch in pulley is at rope insert in housing and hold pulley from turning (Fig. HL121). Pull up a loop of rope between notch and fan housing, then holding loop, turn pulley and rope three turns clockwise (winding spring).

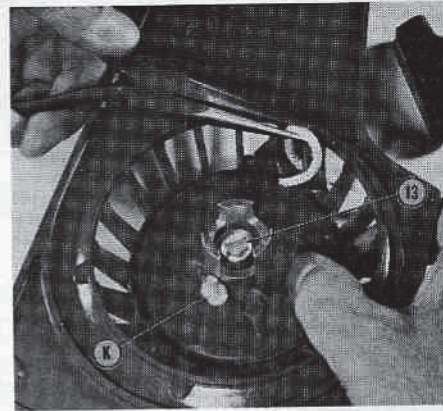

Fig. HL121—Pulling loop of starter rope past notch in rope pulley. Rope is retained by knot (K). Rope pulley retaining screw is (13).

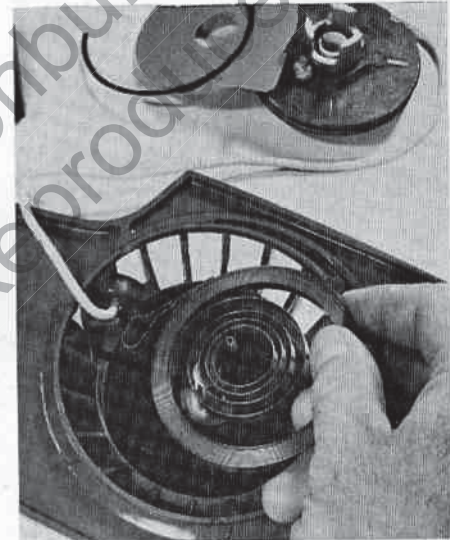

Fig. HL122—Installing rewind spring. Outer (black plastic) spring shield is already installed.

Pull out the rope so that it runs straight from pulley through insert in fan housing, then allow pulley to rewind slowly.

HOMELITE

A **Textron** DIVISION
PORT CHESTER, N.Y. U.S.A.

Fig. HL201 — Exploded view of Tillotson series HL carburetor typical of models used on chain saws in this section. Model HL-117C replacement carburetor is equipped with throttle friction spring (13) and a throttle opening spring (2) is packed with carburetor. Friction spring is used on models WIZ 55 and Super WIZ 55 without governor and on all models with governor.

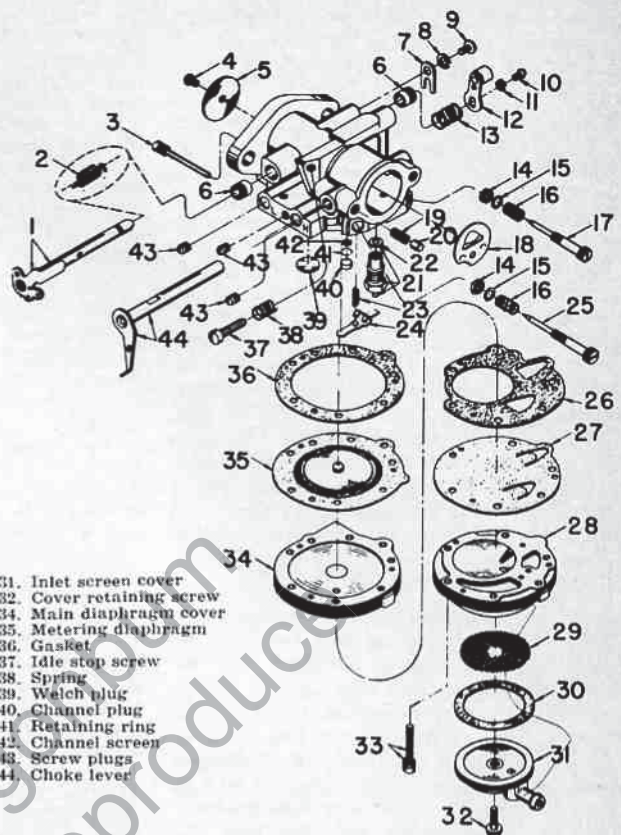

MODEL COVERAGE

| CHAIN SAW MODEL | DESIGN FEATURES |
|--------------------|-----------------|
| ZIP | A,E,J,K,L,O |
| WIZ | B,E,J,K,M,O |
| Super WIZ | A,F,H,K,M,O |
| WIZ 55 | B,G,J,K,M,O |
| Super WIZ 55 | B,F,J,K,M,O |
| Super WIZ 66 | A,F,H,K,M,O |
| Super 77 | C,F,H,K,M,O |
| 775-D | C,F,H,K,L,O |
| 775-G | C,F,H,K,M,O |
| 995-D | C,F,H,K,L,O |
| 995-G | D,F,H,K,N,O |

Design Features Code

- A—Displacement, 4.7 cu. in.; bore 2 in.; stroke, 1½ in.
- B—Displacement, 4.32 cu. in.; bore, 2 in.; stroke, 1¾ in.
- C—Displacement, 5.8 cu. in.; bore, 2¼ in.; stroke, 1 35/64 in.
- D—Displacement, 6.83 cu. in.; bore, 2½ in.; stroke, 1 35/64 in.
- E—Flat reed type intake valve, single reed.
- F—Pyramid reed type intake valve, 4 reeds.
- G—Flat reed type intake valve (E) prior to serial No. 2537289; pyramid reed type valve (F) after serial No. 2537288.
- H—Equipped with air-vane type governor.
- J—Non-governed.
- K—Conventional type flywheel magneto.
- L—Direct drive.
- M—Reduction drive, 2-gear transmission.
- N—Reduction drive, 3-gear transmission.
- O—Manual chain oiler only.

MAINTENANCE

SPARK PLUG. Recommended Champion spark plug is type UJ-7G for models 995D and 995G, type UJ-11G for models Super 77, 775D and 775G and type J-6J for all other models listed.

Set electrode gap to 0.025. Champion J-6J plug may be substituted for type UJ-11G, but will be more susceptible to electrode erosion. In high temperatures or for heavy duty operation, use UJ-7G plug in place of J-6J or UJ-11G. In extremely cold weather, a UJ-12 plug may be used to avoid cold fouling and improve starting.

CARBURETOR. Refer to Fig. HL201 for exploded view of series HL Tillotson carburetor typical of that used; carburetor models HL-104A, HL-105A, HL-117C and HL-119A have been used. Model HL-117C is used as service replacement on models originally equipped with HL-104A or HL-105A carburetor. Models HL-117C and HL-119A are

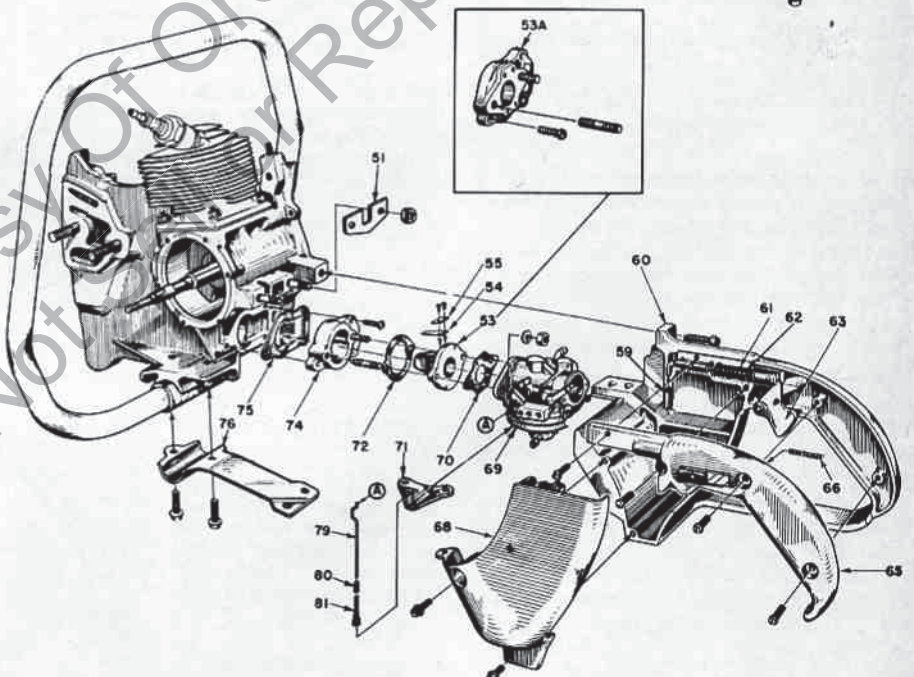

Fig. HL202—Exploded view showing throttle controls and carburetor mounting typical of WIZ series and models Super 77 and 775G. On models WIZ 55 and Super WIZ 55, throttle opening rod (79) and spring (81) are used instead of throttle opening spring (2—Fig. HL201). Throttle rod (61) releases carburetor throttle arm when trigger (63) is actuated, then throttle opening spring (non-governed models) or governor opens carburetor throttle. Flat reed seat (53A) used on some models is shown in inset. Refer to Fig. HL203 or Fig. HL204 for fuel pick-up installation in tank and carburetor air inlet connections.

- | | | | |
|-------------------------|---------------------------|-------------------------|-----------------------------|
| A. Throttle rod hook-up | 59. Throttle rod sleeve | 68. Carburetor shield | 75. Gasket |
| 51. Fuel tank strap | 60. Throttle handle | 69. Carburetor | 76. Brace |
| 53. Pyramid reed seat | 61. Throttle rod | 70. Gasket | 79. Throttle opening rod |
| 53A. Flat reed seat | 62. Throttle spring | 71. Spring bracket | 80. Spacer |
| 54. Inlet reeds | 63. Throttle trigger | 72. Gasket | 81. Throttle opening spring |
| 55. Reed clamps | 65. Handle cover | 74. Pyramid reed spacer | |
| | 66. Throttle latch spring | | |

vented internally; that is, fuel diaphragm is vented to carburetor throat instead of atmospheric vent as on models HL-104A and HL-105A.

Service replacement model HL-117C carburetors have throttle friction spring (13) installed on throttle shaft and throttle opening spring (2) is packaged with carburetor. For installation on models not equipped with governor (except models WIZ 55 and Super WIZ 55), remove friction spring and install throttle opening spring. Springs may be removed or installed by threading past throttle shaft arm. Hook inner end of opening spring on anchor pin and outer end on throttle shaft arm so that throttle is held in open position. On models WIZ 55 and Super WIZ 55, and on models with governor, discard throttle opening spring and leave throttle friction spring installed. When installing service replacement carburetor on some models, it may be necessary to loosen screw (32) and rotate fuel screen cover (31) to align fuel inlet with fuel line.

When troubleshooting fuel system problems, check fuel pick-up filter and hose in tank, fuel tank vent in filler cap and the air filter element. Fuel filter element should be renewed rather than cleaned, and pick-up hose should be flexible and free of kinks or cracks. Check fuel metering diaphragm vent in carburetor throat (carburetor models HL-117C and HL-119A) or in metering diaphragm cover (models HL-104A and HL-105A) to be sure vent is not plugged. Welch plug (39) may be removed by carefully drilling through plug, then inserting pin in hole and prying plug out. To clean channel screen (42), remove plug (40) and retaining ring (41), then remove the screen.

For initial starting adjustment, close both fuel mixture needle lightly (turn clockwise), then open idle fuel needle 3/4 turn counter-clockwise and main fuel needle one to 1 1/4 turns counter-clockwise. Back idle speed stop screw out until throttle disc will fully close, then turn screw back in until it contacts throttle shaft arm plus one additional turn.

Make final adjustment with engine warm and running. Adjust idle speed screw so that engine will run at just below clutch engagement speed, then adjust idle fuel mixture needle so that engine runs smoothly. Readjust idle speed stop screw if necessary. With engine running at full throttle under load (stall chain in cut), adjust main fuel needle so that engine runs at highest obtainable speed without excessive smoke. Idle fuel needle is to left, main fuel needle is to right.

THROTTLE CONNECTIONS. The throttle trigger is not directly connected with the carburetor throttle shaft arm. When throttle trigger is released, the throttle shaft arm should be held against the idle speed stop screw. Squeezing throttle trigger moves the throttle rod or lever away from carburetor shaft arm allowing the throttle opening spring (non-governed models) or governor spring to move throttle to wide open position. Check action of throttle linkage, carburetor throttle shaft and throttle opening or governor spring with engine stopped.

Fig. HL203 — Exploded view showing fuel pick-up installation in tank and carburetor air inlet for models WIZ, Super WIZ, WIZ 55 and Super WIZ 55. Note springs (42) on air inlet elbow to carburetor screws (43). Late filler cap (13) has integral relief valve rather than separate part (14).

7. Fuel line
8. Elbow fitting
9. Pick-up hose
10. Filter head
11. Filter element
12. Fuel tank
13. Filler cap
14. Valve (early)
15. Gasket
30. Gasket
31. Fuel fitting
38. Gasket
39. Inlet elbow
40. Gasket
42. Springs (2)
43. Screws (2)

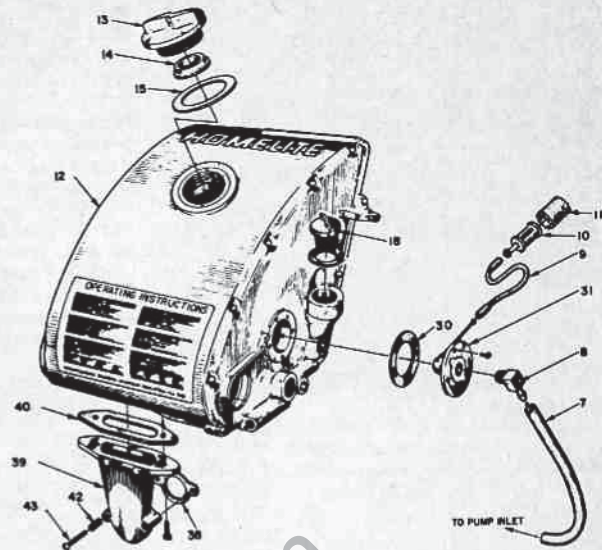

Fig. HL204 — Exploded view showing fuel pick-up, air cleaner and carburetor inlet elbow and fuel tank typical of models Super WIZ 66, Super 77 and 775G. Model 775D is similar except chain oil tank is separate from fuel tank. Springs (9) are used on inlet to carburetor screws.

1. Air filter element
2. Cover
3. Gasket
4. Gasket
5. Stud
6. Pick-up hose
7. Fuel fitting
8. Fuel line
9. Springs
10. Air inlet elbow
11. Gasket
12. Gasket
13. Filter head
14. Filter element
15. Fuel tank

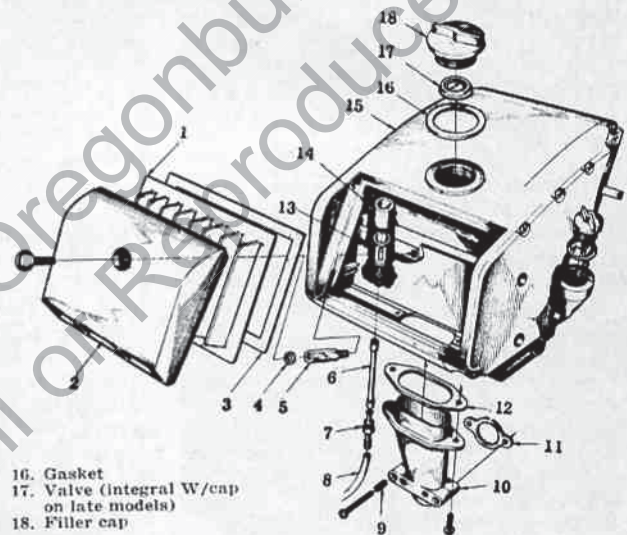
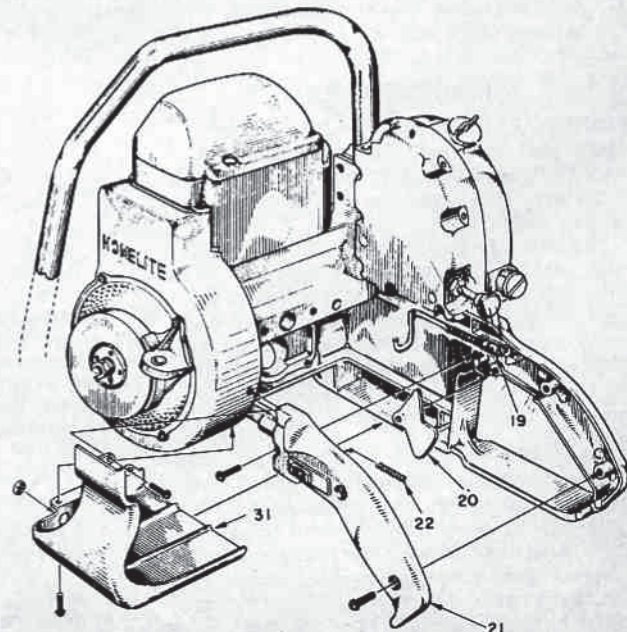
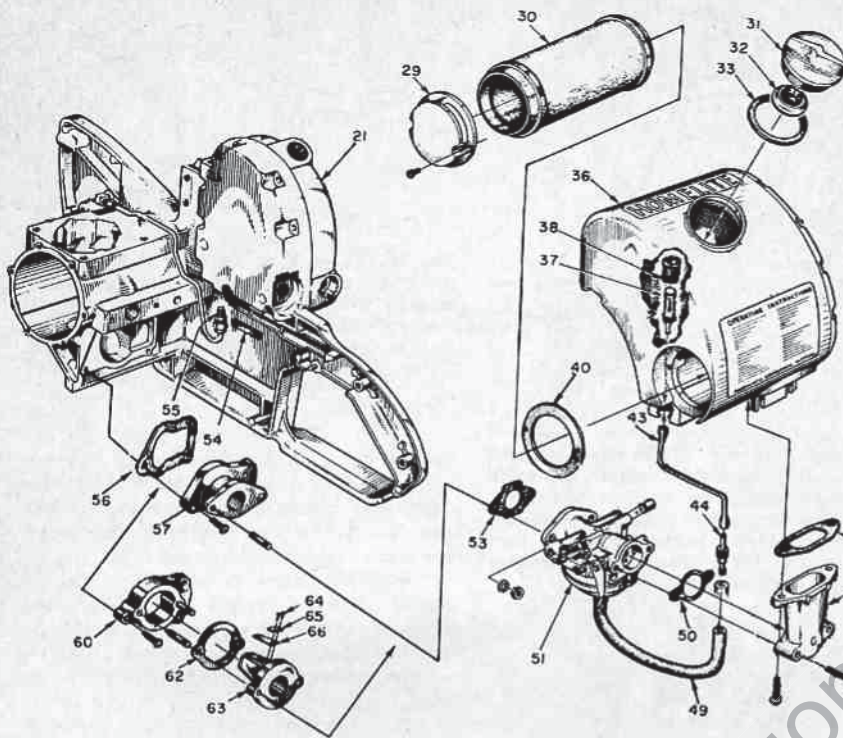

Fig. HL205—View showing throttle trigger and throttle rod installation on models ZIP and 775D; refer to Fig. HL206 for carburetor and reed valves.

19. Throttle rod & return spring
20. Throttle trigger
21. Handle cover
22. Throttle lock spring
31. Carburetor cover





- 21. Crankcase
- 29. Cap
- 30. Air filter
- 31. Filler cap
- 32. Relief valve
- 33. Gasket
- 36. Fuel tank
- 37. Filter head
- 38. Filter element
- 40. Gasket
- 43. Pick-up hose
- 44. Fuel fitting
- 45. Gasket
- 46. Inlet elbow
- 49. Fuel hose
- 50. Gasket
- 51. Carburetor
- 53. Gasket
- 54. Felt pad
- 55. Oil line & check valve
- 56. Gasket
- 57. Reed valve seat (ZIP)
- 60. Reed seat adapter (775D)
- 62. Gasket
- 63. Pyramid reed seat
- 64. Reed screws
- 65. Reed plates
- 66. Valve reeds (4)

Fig. HL206—Exploded view showing fuel tank, air filter, carburetor and reed valve installation on model ZIP. Model 775D is similar except that pyramid reed assembly (items 60 to 66) is used instead of flat reed seat (57) and single reed on model ZIP. Also, model 775D fuel tank and air filter is similar to that shown in Fig. HL204.

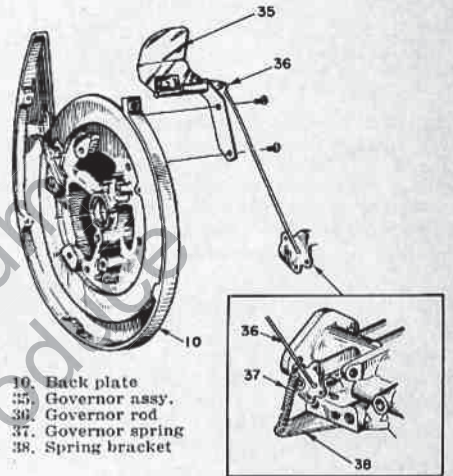

- 10. Back plate
- 35. Governor assy.
- 36. Governor rod
- 37. Governor spring
- 38. Spring bracket

Fig. HL210—View showing Super WIZ governor installation. Refer to Fig. HL215; governor spring attaches to carburetor throttle arm hole numbered (1) and governor link attaches at hole numbered (3).

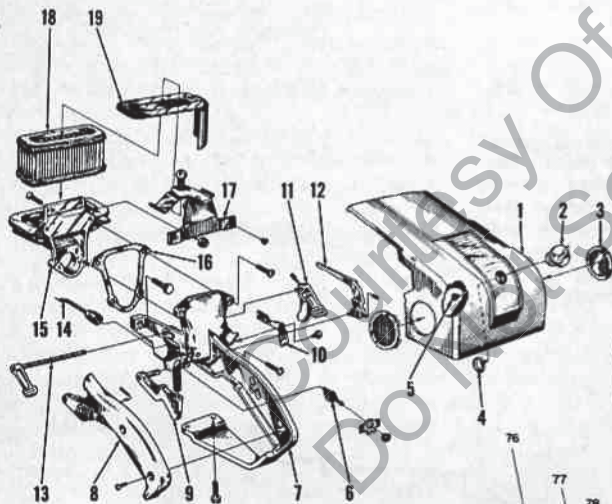

Fig. HL207 — Exploded view of throttle handle, air inlet filter, throttle linkage and cover for models 995D and 995G. Refer to Fig. HL208 for fuel pick-up, carburetor and reed valve installation.

- 1. Cover
- 2. Retaining nut
- 3. Plugs
- 4. Snap ring
- 5. Rubber bumper
- 6. "ON-OFF" switch
- 7. Throttle handle
- 8. Handle cover
- 9. Throttle trigger
- 10. Choke lever
- 11. Oiler lever
- 12. Throttle lever
- 13. Oiler shaft & lever
- 14. Switch ground lead
- 15. Air filter holder
- 16. Gasket
- 17. Bracket
- 18. Air filter element
- 19. Filter cap

- 42. Gasket
- 43. Reed seat adapter
- 44. Gasket
- 45. Valve reeds
- 47. Reed plates
- 48. Pyramid reed seat
- 49. Gasket
- 52. Carburetor
- 53. "O" ring
- 55. Fuel line
- 56. Spring insert
- 58. Fuel fitting
- 59. Gasket
- 60. Pick-up hose
- 76. Filler cap
- 77. Relief valve
- 78. Gasket
- 79. Fuel & oil tank
- 80. Filter head
- 81. Filter element

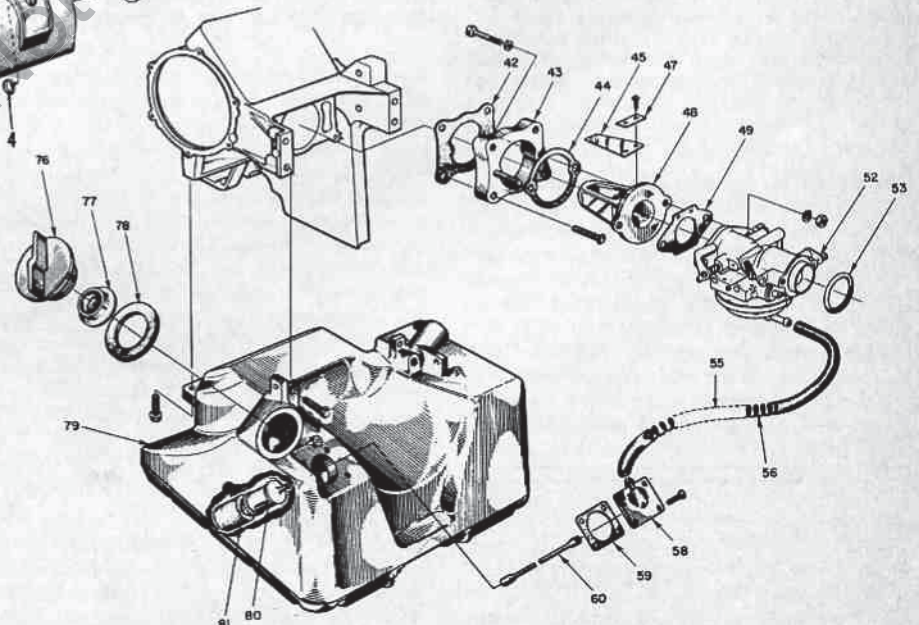
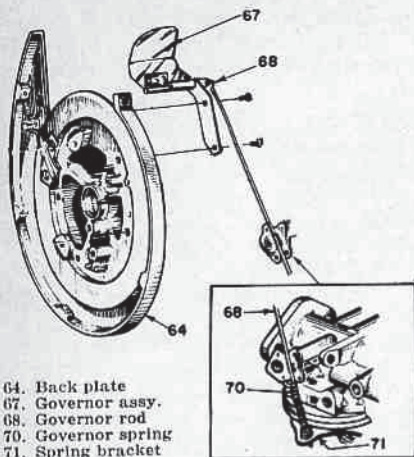

Fig. 208—Exploded view showing fuel pick-up, carburetor and reed valve installation for models 995D and 995G. Throttle handle and linkage are shown in Fig. HL207. Note that a coil spring (56) is inserted in fuel line (56).



- 64. Back plate
- 67. Governor assy.
- 68. Governor rod
- 70. Governor spring
- 71. Spring bracket

Fig. HL211—View showing governor hook-up used on models Super WIZ 66 and Super 77. Refer to Fig. HL215; throttle rod is connected at hole numbered (3). Governor spring (70) is compressed between bracket (71) and shoulder on governor rod.

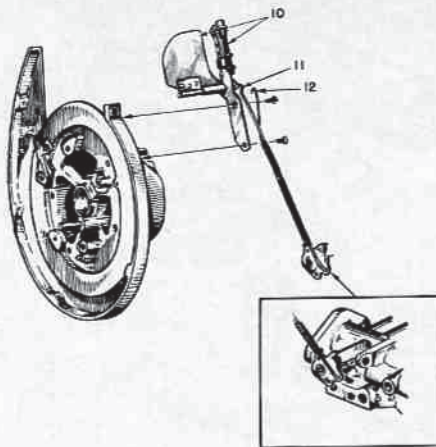
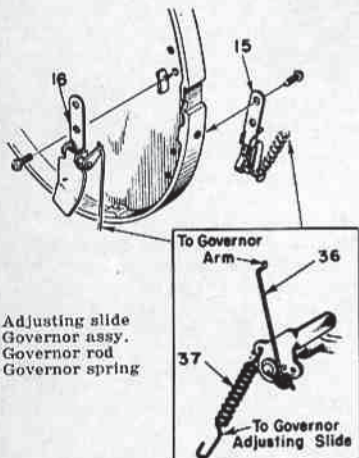

Fig. HL213—Model 775G governor and adjusting slide assembly; adjust governed speed by turning screw on slide. Governor spring (12) connects to adjusting slide and lower end of spring is threaded onto burr washer on rod (11). Hook rod to throttle arm hole numbered (4) (Fig. HL215).



- 15. Adjusting slide
- 16. Governor assy.
- 36. Governor rod
- 37. Governor spring

Fig. HL212—Model 775D governor spring (37) is connected to adjustable slide (15) making it possible to adjust engine governed speed by turning adjusting screw on slide. Refer to Fig. HL215; spring is hooked in throttle arm hole numbered (1) and governor rod is hooked in hole numbered (2).

GOVERNOR. All models except ZIP, WIZ, WIZ 55 and Super WIZ 55 are equipped with an air vane type governor to prevent over-speeding of engine when saw is out of cut. Maximum no-load engine speed should be 7500 RPM; engine peak horsepower is obtained at about 6000 RPM.

With engine not running, check to see that governor spring will fully open throttle when throttle trigger is squeezed to wide open position. With engine warm and run-

- 35. Plug terminal
- 36. High tension wire
- 37. Grommet
- 38. "ON-OFF" switch
- 39. Switch plate
- 40. Ground wire
- 41. Sleeve
- 42. Rotor
- 43. Ignition coil
- 47. Condenser
- 50. Gasket
- 52. Breaker points
- 53. Cam wiper felt
- 56. Ground wire tab
- 57. Armature core
- 58. Cover clip
- 59. Sealing felt
- 61. Wire clamp, inner
- 63. Wire clamp, outer
- 49. Breaker cover

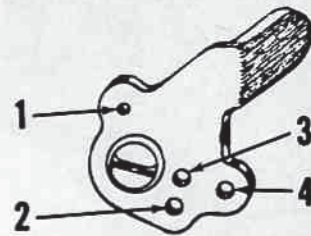

Fig. HL215.—View showing throttle shaft arm typical of all carburetors except for models 995D and 995G. It is important that throttle opening or governor spring and/or link be hooked into proper hole. Refer also to Fig. HL202 and Figs. HL210 through HL213.

ning at no load, governor should limit engine speed to about 7500 RPM by closing carburetor throttle. Check governor air vane and linkage for free operation and renew governor if worn or damaged.

MAGNETO. Refer to Fig. HL217 for exploded view of typical REPCO magneto. Breaker points, coil and condenser are accessible after removing flywheel. Homelite rotor removing tool No. AA-22560 should be used.

Adjust breaker point gap to 0.015. Condenser capacity should test 0.18-0.22 mfd. A new cam wiper felt (53) should be installed whenever breaker points are being renewed. Adjust position of felt so that it lightly contacts cam surface of engine crankshaft.

LUBRICATION. Engine is lubricated by mixing 1/2-pint of Homelite motor oil or good grade SAE 30 motor oil with each gallon of gasoline. Use regular grade gasoline and

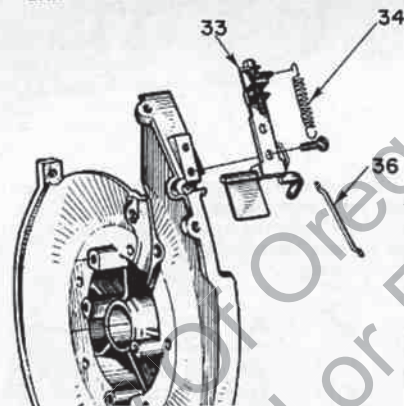

Fig. HL214—View showing governor assembly used on models 995D and 995G. Governor rod is connected to single hole in carburetor throttle shaft arm. Adjust governed speed by turning adjusting slide screw in governor and slide assembly (33). Governor spring (34) is connected between adjustable slide and arm on governor shaft.

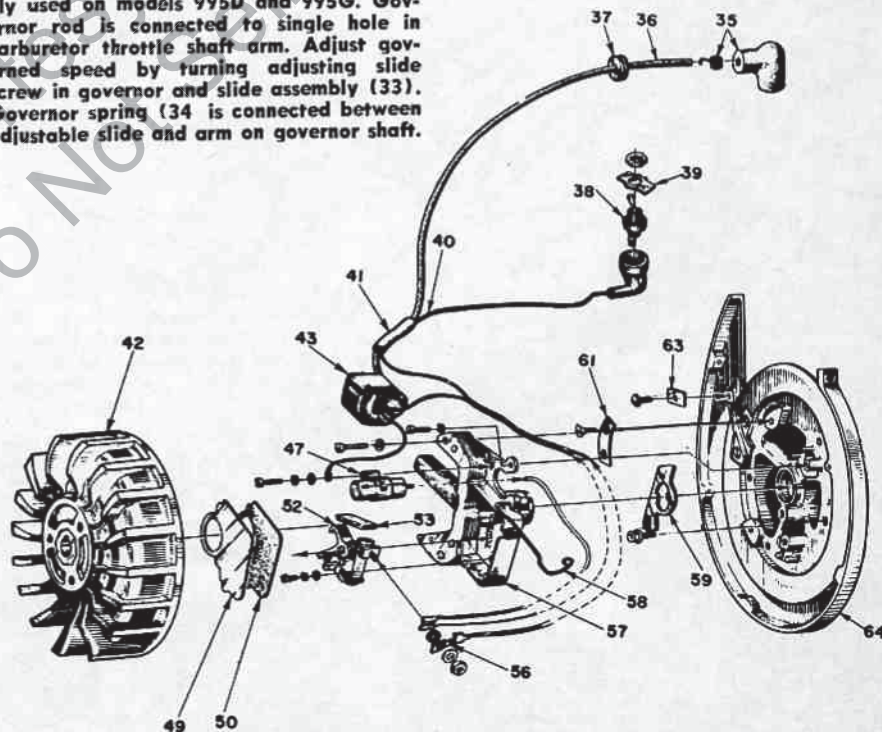

Fig. HL217.—Exploded view of typical REPCO magneto used on all models. Rotor (flywheel) has three tapped holes for installation of remover (Homelite tool No. AA-22560). Magneto back plate (64) supports crankshaft seal and needle bearing.

1. Heat damper
4. Exhaust cap
5. Muffler element
7. Muffler body
10. Saw dust shield
13. Cylinder
16. Gasket
17. Crankcase
18. Crankshaft seal
- 18A. Sprocket shaft seal
22. Gasket
23. Snap ring
24. Ball bearing
25. Special washers
26. Special screws
27. Crankshaft
28. Needle rollers
29. Connecting rod & cap
30. Needle bearing
31. Connecting rod screws
32. Piston & pin
33. Snap rings
34. Piston rings

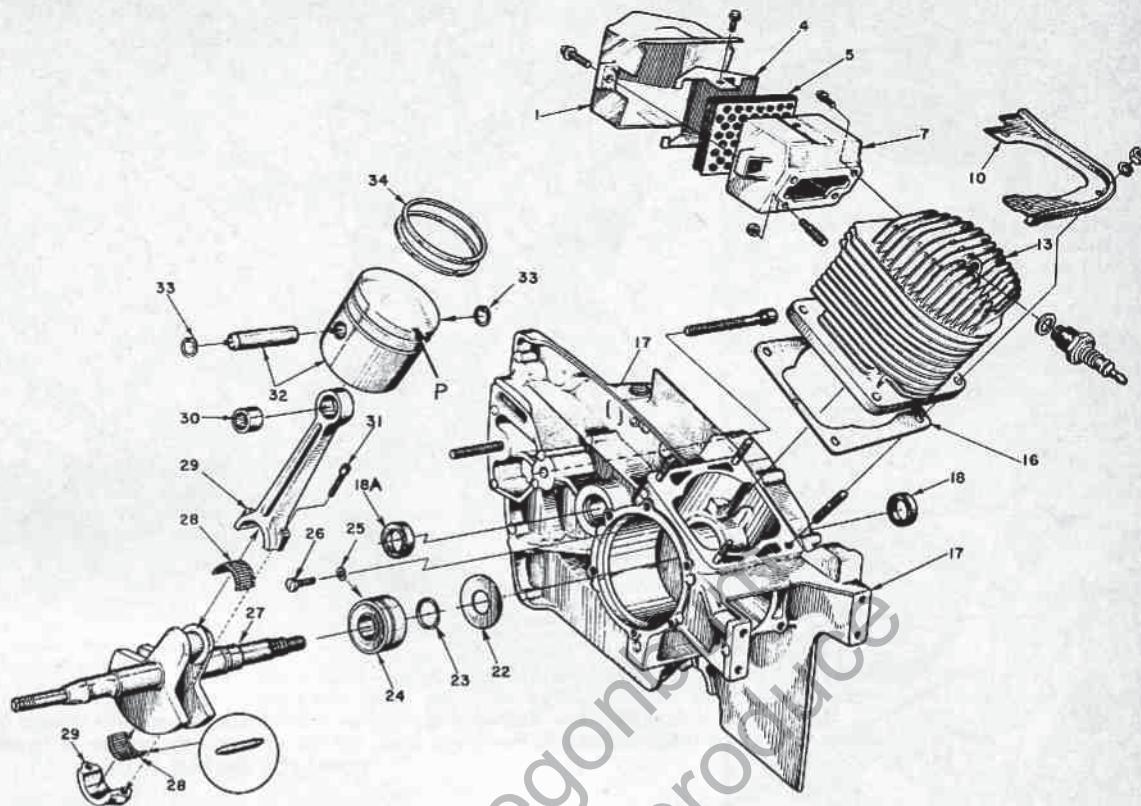

Fig. HL219 — Exploded view of model 995G engine. Cylinder, crankshaft, connecting rod and piston installation of all other models are similar. Models ZIP and 775D are not fitted with crankcase crankshaft seal (18); crankcases on these models are fitted with a close fitting, non-renewable bronze oilite bushing. Note side of piston with ring retaining pin (P) is away from exhaust port (muffler) side of engine.

mix oil and gasoline thoroughly in a separate container.

The clutch drum and sprocket assembly on direct drive models should be removed occasionally and the needle roller bearing be cleaned and lubricated.

On gear drive models, maintain oil level in gear case to arrow on inspection window using Homelite Gear Oil or SAE 90 gear lubricant. Check oil level with saw setting on level surface. Do not overfill.

Chain oiler tank should be filled with Homelite Bar and Chain Oil or SAE 30 motor oil. In low temperatures, dilute chain oil with one part of kerosene to four parts of oil.

CARBON REMOVAL. Carbon deposits should be removed from exhaust ports and muffler at regular intervals. Use a wood scraper and be careful not to damage edges of exhaust ports. Piston should be at top dead center when removing carbon. Do not attempt to start engine with muffler removed.

REPAIRS

CONNECTING ROD. Connecting rod and piston assembly can be removed after removing cylinder from crankcase. Be careful to remove all of the loose needle rollers when detaching rod from crankpin. Models ZIP, WIZ, Super WIZ, WIZ 55, Super WIZ 55 and Super WIZ 66 have 27 needle rollers and models Super 77, 775D, 775G, 995D and 995G have 31 loose needle rollers.

Renew connecting rod if bent or twisted, or if crankpin bearing surface is scored, burned or excessively worn or if Formica thrust washers are deeply grooved or are not completely bonded to rod. The caged needle roller piston pin bearing can be renewed by pressing old bearing out and new bearing in using Homelite tool No. 23372 on models 995D and 995G, or tool No. A-23809 for other models. Press on lettered end of bearing cage only.

Homelite recommends renewing the crankpin needle rollers at each overhaul. New needle rollers are supplied in a wax strip; wrap the strip around crankpin, then assemble connecting rod to cap on the crankpin. When reassembling engine after inspection, use light grease or beeswax to stick 16 rollers to rod and cap. Install piston and connecting rod assembly so that pinned ends of piston rings are away from exhaust port (muffler) side of engine.

On models ZIP, WIZ, Super WIZ, WIZ 55, Super WIZ 55 and Super WIZ 66, tighten the connecting rod cap screws to a torque of 55-60 inch-pounds. On models Super 77, 775D, 775G, 995D and 995G, tighten rod cap screws to a torque of 70-80 inch pounds. Wiggle rod and cap as the screws are tightened to align fracture mating surfaces.

PISTON, PIN AND RINGS. Piston can be removed from connecting rod after removing cylinder. Support the piston while removing and installing piston pin. Pin is retained in piston by a snap ring at each end of pin.

The aluminum alloy piston is fitted with two pinned piston rings. Ring width is

0.037 and end gap should be 0.070-0.080. Rings should be renewed if end gap exceeds 0.100. Minimum ring side clearance is 0.0025; maximum ring side clearance in ring groove is 0.004. Piston, pin and rings are available in standard size only.

Renew piston and pin, which are not available separately, if any of the following defects are noted: Visible up and down play of pin in piston bore, cracks in piston or hole in piston dome, scoring of piston accompanied by aluminum deposits in cylinder bore, piston ring locating pin worn to half of original thickness, or if side clearance of new ring exceeds 0.004. Refer to CYLINDER paragraph for information on removing aluminum deposits from cylinder bore.

Assemble piston to connecting rod or install piston and rod assembly so that ring locating pin side of piston is towards intake side of cylinder (away from exhaust ports). Always use new piston pin retaining snap rings.

CYLINDER. Cylinder bore is chrome plated; plating is light gray in color and does not have appearance of polished chrome. Because cylinder is honed after plating, the chrome bore looks much like the base metal of the aluminum cylinder. If plating has been penetrated by scoring or other causes, the aluminum exposed will appear as a bright area. These bright areas are usually, but not always, located at edges of cylinder ports. If further checking, as outlined in following paragraph, shows

Reed lift distance

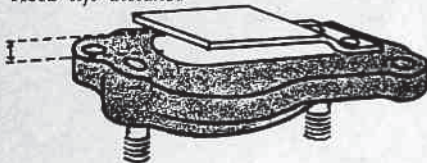

Fig. HL220 — Reed lift distance should be 0.085 for model ZIP and 0.190 for WIZ and WIZ 55 with flat reed.

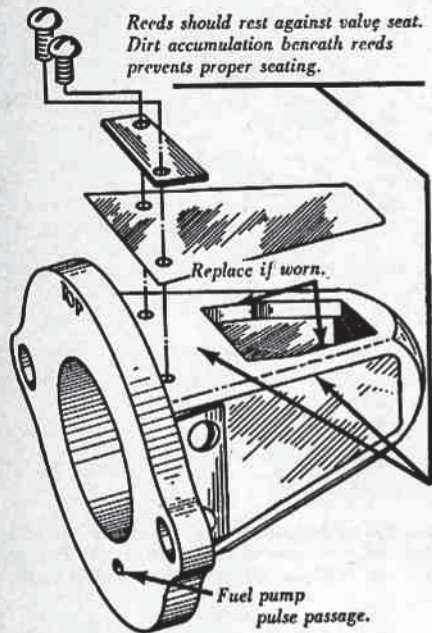

Fig. HL221 — Inspection points for pyramid reed seat and reeds.

that chrome has been penetrated, the cylinder should be renewed.

In some instances, particles of metal from scored piston are deposited on the cylinder bore. This condition is indicated by a rough appearance and deposits can be removed using a rubber impregnated grinding wheel mounted in a 1/4-inch electric drill. If a screwdriver will scratch the cleaned surface, chrome plating has been worn away and the cylinder should be renewed. Also, renew the cylinder if cracked or if more than three critical cooling fins are broken off.

When installing both a new piston and a new cylinder, clean and oil both parts and place piston in cylinder bore without rings or connecting rod. The piston should fall freely when cylinder is turned up. If not, select a new piston or a new cylinder that will give this desired fit.

CRANKSHAFT, BEARINGS AND SEALS.

The drive end of the crankshaft is supported in a ball bearing (24—Fig. HL219) which is retained in crankcase by two screws (26) and special washers (25) which engage groove in ball bearing outer race. Crankshaft is held in position by a snap ring (23) at outer side of bearing. The flywheel end crankshaft journal rotates in a caged needle

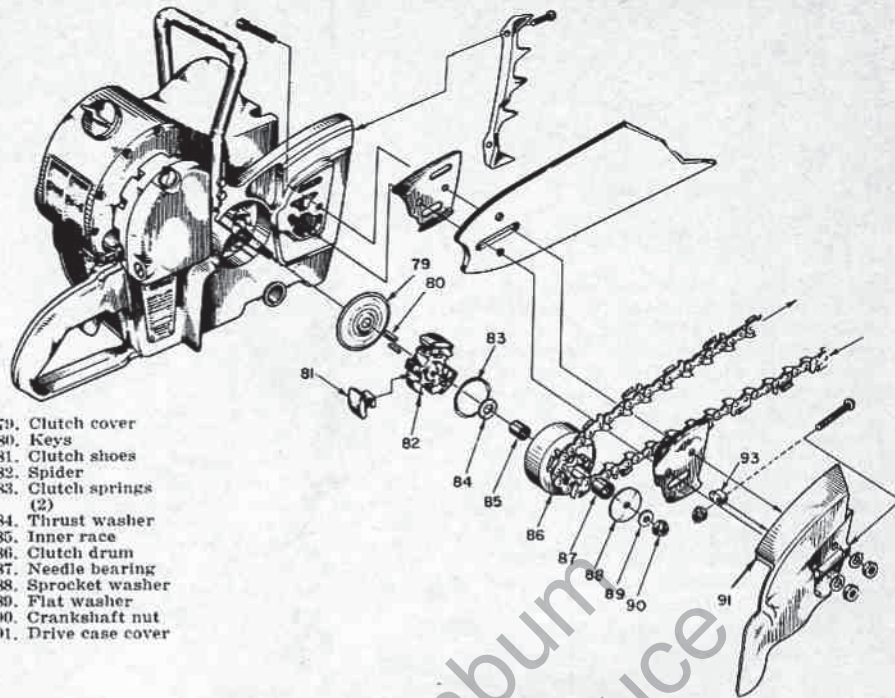

- 79. Clutch cover
- 80. Keys
- 81. Clutch shoes
- 82. Spider
- 83. Clutch springs (2)
- 84. Thrust washer
- 85. Inner race
- 86. Clutch drum
- 87. Needle bearing
- 88. Sprocket washer
- 89. Flat washer
- 90. Crankshaft nut
- 91. Drive case cover

Fig. HL222 — Exploded view of model ZIP clutch assembly. Model 775D is similar except that six clutch shoes are used instead of three and spider is threaded to crankshaft instead of using keys (80).

roller bearing supported in magneto back plate (64—Fig. HL217).

To remove crankshaft, first remove cylinder, piston and connecting rod assembly, clutch spider and drum, flywheel (magneto rotor) and magneto back plate. Note: on models with governor be sure to disconnect governor linkage before attempting to remove back plate. Remove the two bearing retaining screws (26) and washers (25), then bump or push crankshaft and bearing from crankcase. To remove ball bearing, remove snap ring (23) and press crankshaft from bearing.

Renew magneto end needle bearing if any roller shows visible wear or flat spot, or if rollers can be separated more than width of one roller. Renew drive end ball bearing if bearing is rough or has perceptible wear. Inspect crankshaft magneto end and crankpin journals and renew crankshaft if wear marks are visible. Also, renew crankshaft if tapered end fits loosely in magneto rotor or if keyway is enlarged. Crankshaft runout should not exceed 0.003.

New crankshaft seals and sealing gasket should always be installed when reassembling engine. Install new seal in crankcase (except on models ZIP and 775D) with lip of seal inward (towards main bearing position). Install ball bearing on crankshaft with retaining groove in outer race towards crankshaft throw, then install retaining snap ring. Soak new gasket in oil, then position gasket in crankcase. Install crankshaft and bearing using seal protector sleeve and jackscrew, then secure bearing in position using new special washers and screws. Install new seal in back plate with lip inward and install new needle roller bear-

ing by pressing on lettered end. Then, using seal protector, install back plate with new gasket.

Homelite special tools for installing bearings, crankshaft seals and crankshaft are as follows:

Models 995D & 995G:

- A-23137—Jackscrew, crankshaft and bearing.
- 23136—Jackscrew body.
- 23382—Spacer, crankshaft.
- 23373—Collar, crankshaft and bearing
- 23383—Plate, shaft aligning.
- 22391—Plug, back plate bearing and seal.
- 23233—Plug, back plate seal installation.
- 23384—Plug, crankcase seal.
- 23422—Sleeve, crankshaft seal.

All Models Except 995D & 995G:

- A-23137—Jackscrew, crankshaft and bearing.
- 23136—Jackscrew body.
- 22820-1—Collar, crankshaft and bearing.
- 22812-1—Plate, shaft aligning.
- 23391-1—Plug, back plate bearing.
- 23233—Plug, back plate & crankcase seal.
- 23232—Sleeve, crankshaft seal.

CRANKCASE. With crankshaft and bearing removed, check bearing bore. A lapped appearance indicates that the bearing outer race has been turning in the bore. If bearing fits loose in bore, renew the crankcase and/or bearing as necessary to obtain a tight fit. New ball bearing special retaining washers and screws should always be used when reassembling.

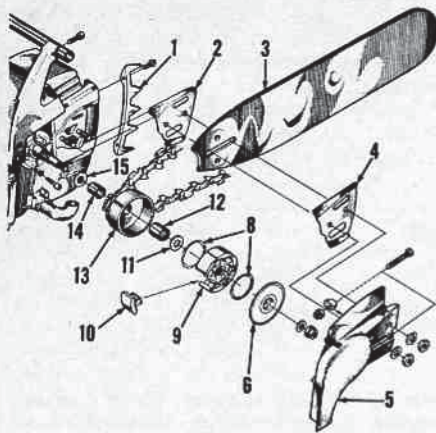

Fig. HL223 — Exploded view of model 995D drive clutch. Spider (9) must be removed from engine crankshaft to service clutch drum (13), bearing and inner race.

- | | |
|--------------------------|--------------------|
| 1. Spike | 8. Clutch springs |
| 2. Inner guide bar plate | 9. Clutch spider |
| 3. Guide bar | 10. Clutch shoes |
| 4. Outer guide bar plate | 11. Thrust washer |
| 5. Drive cover | 12. Needle bearing |
| 6. Clutch cover | 13. Clutch drum |
| | 14. Inner race |
| | 15. Thrust washer |

REED VALVE. The reed valve should be inspected whenever carburetor is removed. Model WIZ 55 prior to serial No. 2537288 and models ZIP and WIZ are equipped with a single reed valve; all other models are equipped with a pyramid reed type valve. Single reed type valve should be renewed if reed has loosened or if reed and/or reed seating surface are worn or damaged. Reed lift should be checked as shown in Fig. HL220.

On pyramid reed type valve, individual reeds may be renewed. Refer to Fig. HL221 for inspection of the pyramid reed valve assembly.

CLUTCH. A shoe type clutch is used on all models and except on model ZIP, clutch rotor is threaded to engine crankshaft. Clutch spider on model ZIP is keyed and press fitted to crankshaft; use puller (Homelite tool No. A-23131) to pull spider from crankshaft. On models 775D, 995D and 995G, the rotor and crankshaft have left hand threads; lock engine from turning and turn rotor clockwise to remove. All other models have right hand threads.

On models ZIP and 775D, refer to Fig. HL222 for exploded view of clutch assembly. Exploded view of model 995D clutch is shown in Fig. HL223. On gear drive models, the clutch is located inside the transmission cover; refer to Fig. 224 for exploded view showing model 995G 3-gear transmission and to Fig. HL225 for exploded view of 2-gear transmission used on all other gear drive models.

Clutch shoes on direct drive models are of Oillite bronze. On gear drive models, the clutch shoes have $\frac{1}{8}$ -inch thick bonded Raybestos linings. Model ZIP is equipped with three clutch shoes; all other models have six clutch shoes. On models WIZ, Super WIZ, WIZ 55, Super WIZ 55 and Super WIZ 66, standard clutch shoes are $\frac{3}{8}$ -inch wide; optional heavy duty clutch shoes are $\frac{3}{4}$ -

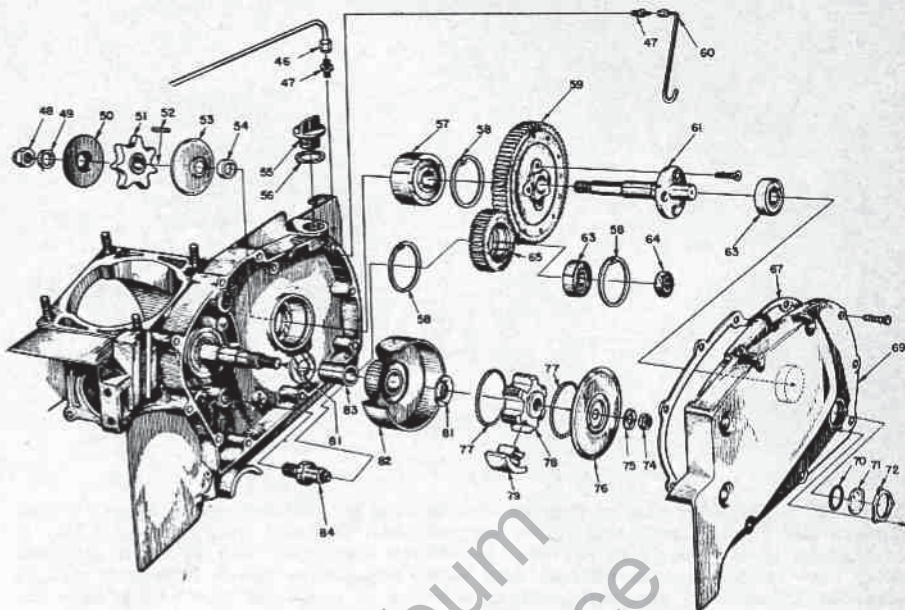

Fig. HL224 — Exploded view of model 995G three-gear transmission. Standard gear ratio is 2.84:1; gears providing 3.57:1 ratio are available. Standard output gear has 71 teeth; optional output gear has 25 teeth. Clutch drum gear has 25 teeth for standard ratio or 21 teeth for optional 3.57:1 ratio.

- | | | | |
|------------------------|--------------------------|------------------------|---------------------------|
| 47. Fitting | 55. Filler cap | 66. Idler gear | 77. Clutch springs |
| 48. Sprocket shaft nut | 56. Gasket | 67. Gasket | 78. Spider |
| 49. Sprocket spacer | 57. Ball bearing | 68. Transmission cover | 79. Clutch shoes |
| 50. Sprocket washer | 58. Snap rings | 69. "O" ring | 80. Thrust washers |
| 51. Sprocket | 59. Driven (output) gear | 70. Window | 81. Clutch drum & gear |
| 52. Sprocket key | 61. Sprocket shaft gear | 71. Window plate | 82. Bronze bushing |
| 53. Sprocket washer | 63. Ball bearing | 72. Crankshaft nut | 83. Idler gear stud shaft |
| 54. Sprocket spacer | 64. Idler shaft nut | 73. Flat washer | |
| | | 74. Clutch cover | |

inch wide. Standard and heavy duty clutch components are not individually interchangeable; also, a different gear case cover is required with heavy duty clutch.

On direct drive models, the clutch drum should be removed occasionally and the needle bearing cleaned and relubricated. A high temperature grease such as Aero Shell #L-14, Aero Shell #5, Texaco Unitemp #500 or Humble (Esso) Nebula EPI should be used. Needle roller bearing should be renewed if rollers can be separated the width of one roller and clutch drum is otherwise serviceable. Press on lettered end of bearing cage only when removing and installing needle bearings. On gear drive models, the clutch drum is equipped with a renewable bronze bushing.

Homelite tool No. A-23696 can be used with wrench to remove clutch spider. When assembling clutch, be sure that end loops of springs are closed and are located at the center of a clutch shoe. If installing new clutch drum, wash off protective coating with petroleum solvent.

TRANSMISSION. Model 995G is equipped with a 3-gear transmission as shown in Fig. HL224. Other gear drive models have a 2-gear transmission as shown in Fig. HL225.

To service transmission, first drain oil from transmission case, then remove the screws retaining cover to case. Tap cover lightly, if necessary, to loosen gasket seal and remove the cover

On model 995G, remove nut (74—Fig. HL224), lock washer and clutch cover (76), block engine from turning and unscrew clutch rotor (78) in a clockwise direction using Homelite tool No. A-23696. Remove clutch drum (82) and the two thrust washers (81). Unscrew nut (64) and remove idler gear (65) and bearing assembly. If necessary to renew bearing (63), remove snap rings (58) and press bearing from gear. Remove gear case vent tube, sprocket nut (48), sprocket (51) and related parts. Then, using soft mallet, bump sprocket shaft from case. To remove ball bearing (57), remove retaining snap ring (58) and press bearing from case using Homelite special tool No. 23389. If bearing (63) remained in cover, heat cover slightly to free the bearing; otherwise, press sprocket shaft from bearing. Remove output gear from sprocket shaft after removing retaining screws. Reassemble by reversing disassembly procedure, reinstall cover with new gasket and fill to proper level with lubricant.

On all two-gear models, remove nut (1—Fig. HL225) from crankshaft, remove washer and clutch cover (3) and using Homelite special tool No. A-23696, turn clutch spider counter-clockwise while holding engine from turning to remove the spider and shoe assembly. Remove clutch drum (7) and thrust washers (8) from crankshaft. Remove sprocket nut (10), sprocket (12) and related parts, then using soft mallet, bump sprocket shaft (20) and gear from case. Remove snap

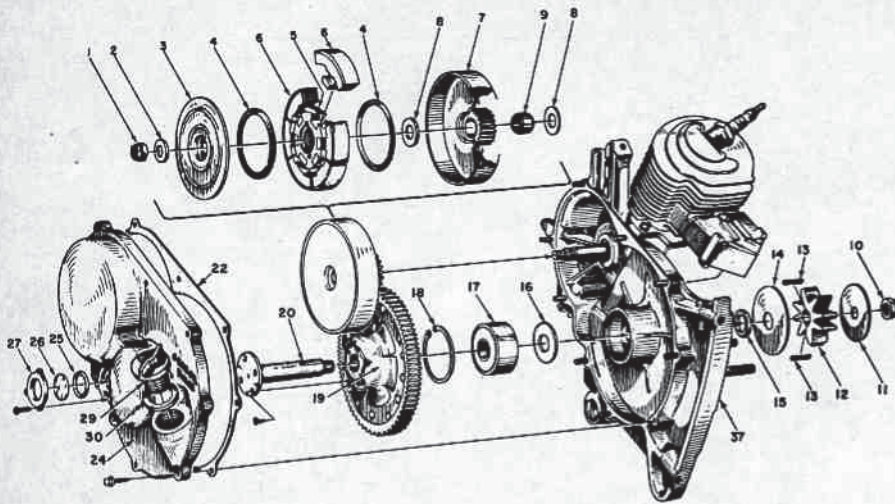

Fig. HL225 — Exploded view of two-gear transmission for WIZ and model Super 77. One standard and two optional gear ratios are available. Standard gear ratio of 3.57:1 is provided by output gear with 75 teeth and clutch drum gear with 21 teeth. Optional 2.84:1 ratio requires output (driven) gear with 71 teeth and clutch drum gear with 25 teeth. On 2:1 optional gear ratio, output gear has 64 teeth and clutch drum gear has 32 teeth.

- | | | | |
|-----------------------|------------------------|--------------------------|---------------------------|
| 1. Crankshaft nut | 8. Thrust washers | 16. Formica seal | 25. "O" ring |
| 2. Flat washer | 9. Bronze bushing | 17. Ball bearing | 26. Window |
| 3. Clutch cover | 10. Sprocket shaft nut | 18. Snap ring | 27. Window plate |
| 4. Clutch springs | 11. Sprocket washer | 19. Driven (output) gear | 28. Filler cap |
| 5. Clutch spider | 12. Chain sprocket | 20. Sprocket shaft | 29. Gasket |
| 6. Clutch shoes | 13. Sprocket keys | 22. Gasket | 30. Crankcase & gear case |
| 7. Clutch drum & gear | 14. Sprocket washer | 24. Transmission cover | |

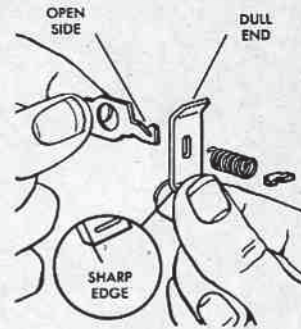

Fig. HL229 — If Fairbanks-Morse starter friction shoe assembly is disassembled, be sure to reassemble as shown.

ring (18), then press bearing from case using Homelite special tool No. 23228. Renew the Formica seal (16) before installing new bearing. Remove retaining screws, then remove output gear (19) from sprocket shaft. Reverse disassembly procedure and use Fig. HL225 as a guide to reassemble. Reinstall cover with new gasket and fill transmission to proper level with lubricant.

STARTER. Three different types of starters are used. Refer to the appropriate following paragraph for information regarding the Fairbanks-Morse starter used on models ZIP, WIZ, Super WIZ, WIZ 55, Super WIZ 55, Super WIZ 66 and Super 77, the ball drive starter used on models 775D and 775G or the over-running clutch type starter used on models 995D and 995G.

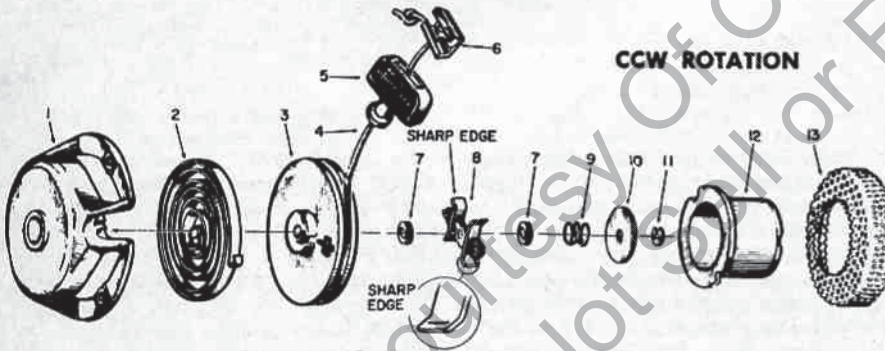

Fig. HL227 — Fairbanks-Morse counter-clockwise rotation starter similar to that used on model ZIP. Refer to Fig. HL229, for assembly of friction shoe assembly (8) if unit has been disassembled. Note direction of sharp edge on shoes when reassembling starter. Refer to Fig. HL228 for legend.

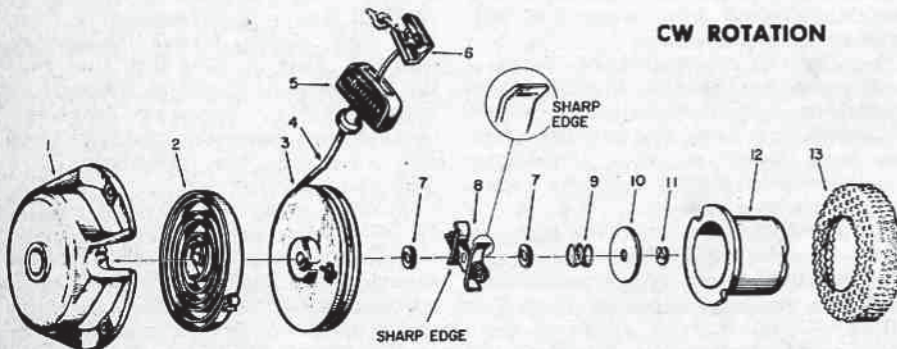

Fig. HL228 — Exploded view of Fairbanks-Morse starter used on WIZ series and model Super 77. Fig. HL229 shows proper method of assembling friction shoe assembly if it has been disassembled for some reason; individual parts of friction shoe assembly are not available. Note direction for sharp edges of shoes when reassembling starter.

FAIRBANKS-MORSE STARTER. Refer to Fig. HL227 for exploded view showing counter-clockwise rotation starter used on model ZIP and to Fig. HL228 for clockwise rotation starter used on WIZ series of models and Super 77. When installing rewind spring, pulley and rope, spring should be pre-tensioned so that pulley will rewind all rope and pull rope handle lightly against starter housing. If spring is tensioned too tightly, or if starter rope is too long, spring can be damaged by being wound too tightly when starter rope is pulled out. The starter clutch (8) is available as an assembly only. If clutch has been disassembled for some reason, it must be reassembled as shown in Fig. 229. Be sure that starter is properly placed on starter pulley so that sharp edges of clutch shoes are pointing in direction shown in Fig. HL227 on model ZIP or as shown in Fig. HL228 for other models using this type starter.

- | | |
|------------------|------------------------|
| 1. Cover | 8. Friction shoe assy. |
| 2. Rewind spring | 9. Brake spring |
| 3. Rope pulley | 10. Retaining washer |
| 4. Starter rope | 11. Retaining ring |
| 5. Handle grip | 12. Starter cup |
| 6. Grip insert | 13. Starter screen |
| 7. Brake washers | |

BALL DRIVE STARTER. Refer to Fig. HL-230 for exploded view of ball drive starter used on model 775G. Starter for model 775D is similar except for being counter-clockwise instead of clockwise rotation. Hub (22), which is attached to rope pulley (39) by four screws (41), drives ratchet (26) through friction. Thus, if engine kicks back while cranking, the ratchet should slip in hub. Drive torque should be 170 to 180 inch-pounds and is adjusted by tightening or loosening hub clamp screw (24). The ball drive assembly (16) is retained on engine crankshaft by crankshaft nut (32). Ball drive plate (17) is attached to engine flywheel and engine is cranked by steel balls (18) which engage ratchet (26) and ball drive plate. When engine is running, centrifugal force disengages drive balls from ratchet and crankshaft turns in the needle bearings (28) in ratchet. Rewind spring (35) inner hook engages roll pin (23) carried in bores in ratchet and rope pulley.

Use Fig. HL230 as disassembly and re-assembly guide, remembering that on model 775D, rewind spring, rope pulley and rope are assembled in reverse of positions shown. Drive torque can be checked using torque wrench and special key (Homelite tool No. A-22224).

OVER-RUNNING CLUTCH STARTER. Refer to Fig. HL231 for exploded view of over-running clutch type starter used on models 995D and 995G. When starter pulley (10) is turned, over-running bearing (14) engages inner race (17) which is pinned to flywheel with pin (45).

Over-running bearing (14) is a press fit and can be removed using Homelite special tool No. A-23679. When installing new bearing, be sure end marked "LOCK" as shown in Fig. HL231 is towards rope pulley (10). Install bearing using plug, Homelite tool No. 23678.

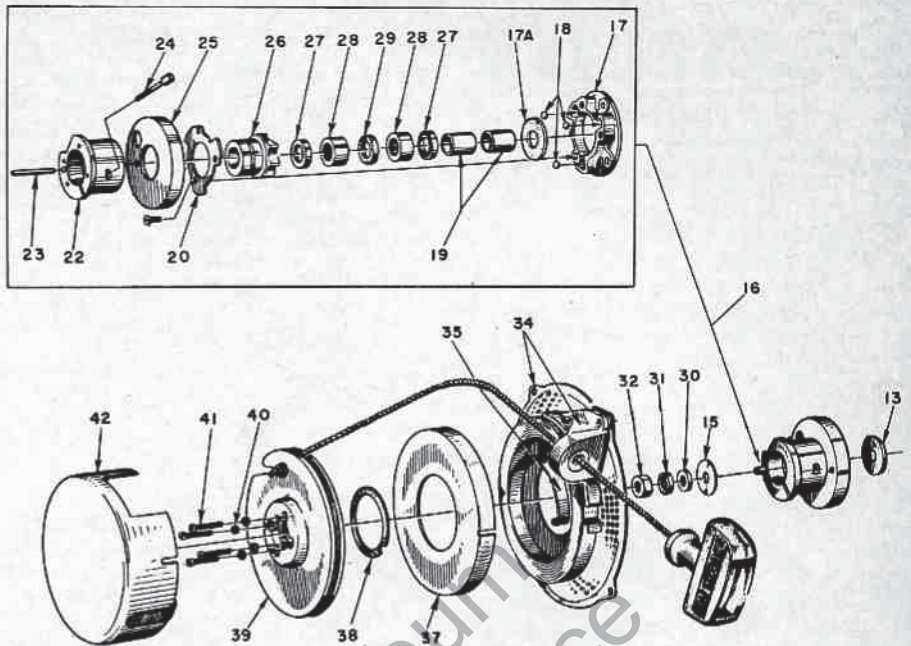

Fig. HL230 — Exploded view of Homelite ball drive starter for model 775G. Starter for model 775D is similar except it is designed for counter-clockwise rotation. Tension screw (24) should be adjusted so that hub (22) will drive ratchet (26) to crank engine, but ratchet will slip in hub if engine kicks back. Torque transmitted through hub and ratchet can be measured by locking engine, removing two opposite screws (41) from pulley and turning pulley with special key (Homelite tool No. A-22224) and inch-pound torque wrench. Torque should be 170-180 inch-pounds.

- | | | | |
|-------------------------|---------------------|--------------------------|-------------------|
| 13. Thrust washer | 19. Inner races | 28. Needle bearings | 35. Rewind spring |
| 15. Thrust washer | 20. Ball retainer | 29. Felt wick | 37. Spring cover |
| 16. Ball drive assembly | 22. Drive hub | 30. Thrust washer | 38. Plastic shim |
| 17. Ball drive plate | 23. Spiral pin | 31. Flat aluminum washer | 39. Rope pulley |
| 17A. Formica washer | 24. Adjusting screw | 32. Crankshaft nut | 40. Lock washers |
| 18. Steel balls | 25. Sealing cup | 34. Screen & bracket | 41. Screws |
| | 26. Ratchet | | 42. Cover |
| | 27. Garlock seals | | |

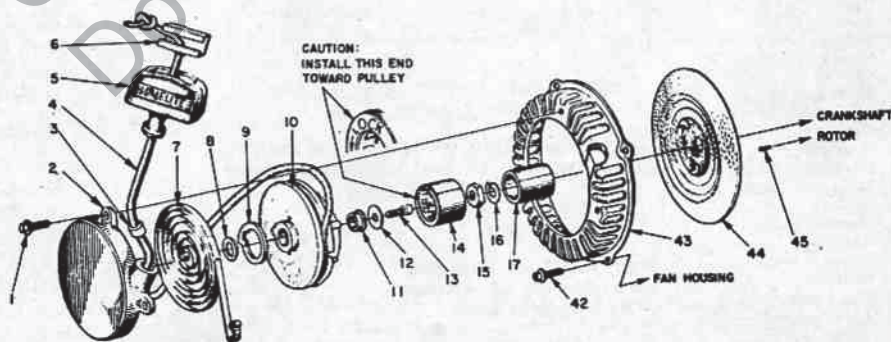

Fig. HL231 — Exploded view of over-running clutch starter used on models 995D and 995G. Special tools required to remove and install over-running bearing (14) are puller (Homelite tool No. A-23679).

- | | | | |
|------------------|--------------------|--------------------------|-------------------------------|
| 2. Cover | 8. Thrust washer | 13. Socket head screw | 16. Lock washer |
| 3. Bushing | 9. Rewind lock | 14. Over-running bearing | 17. Inner race |
| 4. Starter rope | 10. Starter pulley | 15. Crankshaft nut | 43. Mounting ring |
| 7. Rewind spring | 11. Bushing | | 44. Rotating screen |
| | 12. Thrust washer | | 45. Dowel pin (race to rotor) |

HOMELITE

A **textron** DIVISION
PORT CHESTER, N.Y. U.S.A.

MODEL COVERAGE

| | |
|----------------------------|------------------|
| 5-30N Belt Drive Chain Saw | |
| Displacement, Cu. In. | 6.97 |
| Bore, In. | 2 $\frac{7}{16}$ |
| Stroke, In. | 1 $\frac{1}{2}$ |
| Chain Oiler | Manual |

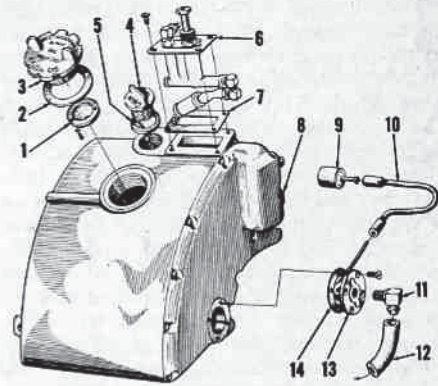

Fig. HL238—Exploded view of fuel tank and oil reservoir. Refer to Fig. HL243 for exploded view of oil pump (6).

- | | |
|----------------------|--------------------------|
| 1. Relief valve | 8. Fuel tank |
| 2. Gasket | 9. Fuel pick-up & filter |
| 3. Fuel tank cap | 10. Flexible hose |
| 4. Oil reservoir cap | 11. Elbow |
| 5. Gasket | 12. Carburetor hose |
| 6. Oil pump | 13. Outlet fitting |
| 7. Gasket | 14. Gasket |

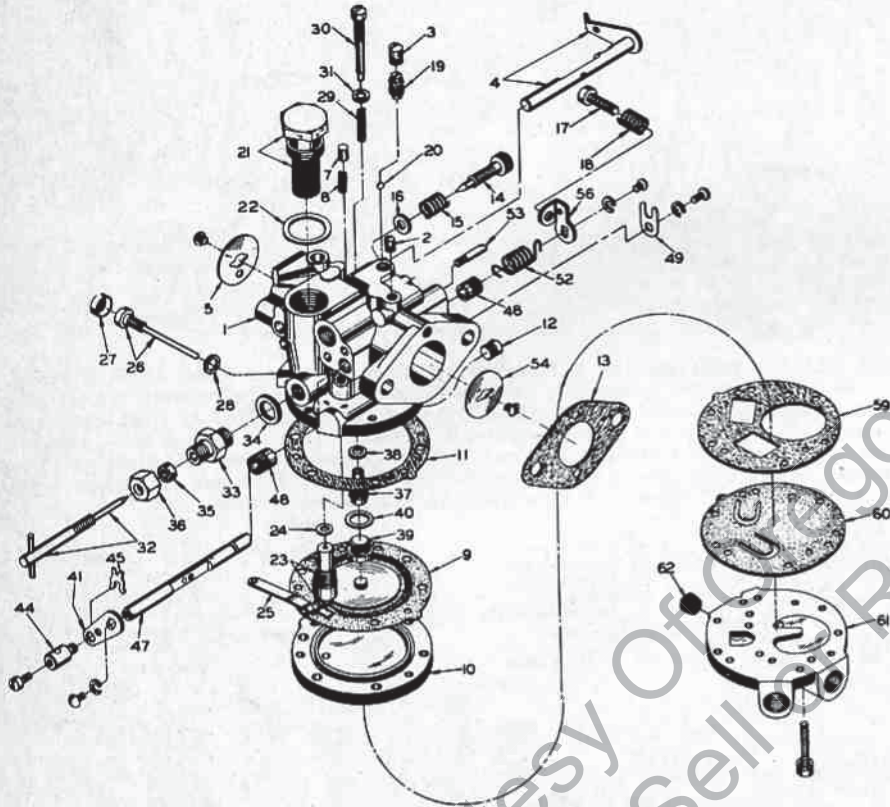

Fig. HL235—Exploded view of Tillotson HP-19B diaphragm type carburetor. Refer to Fig. HL236 for checking fuel diaphragm lever (25). For proper fuel diaphragm spring (29) tension, two copper washers (31) must be used on spring tension adjusting screw (30).

- | | |
|---------------------------|-----------------------------|
| 1. Body | 26. Lever pin screw |
| 2. Channel plug | 27. Lever pin cap |
| 3. Channel plug | 28. Gasket |
| 4. Choke shaft & lever | 29. Tension spring |
| 5. Choke shutter | 30. Tension screw |
| 7. Choke friction pin | 31. Copper washers (2) |
| 8. Friction pin spring | 32. Main fuel needle |
| 9. Metering diaphragm | 33. Fuel needle gland |
| 10. Diaphragm cover | 34. Gasket |
| 11. Diaphragm gasket | 35. Packing |
| 12. Drain plug | 36. Packing nut |
| 13. Mounting gasket | 37. Main fuel nozzle |
| 14. Idle fuel needle | 38. Gasket |
| 15. Friction spring | 39. Channel plug |
| 16. Spring washer | 40. Gasket |
| 17. Idle speed screw | 41. Throttle lever |
| 18. Friction spring | 44. Connector |
| 19. Idle check valve seat | 45. Clip washer |
| 20. Idle check valve ball | 47. Throttle shaft |
| 21. Inlet screen | 48. Throttle shaft bushings |
| 22. Gasket | 49. Clip |
| 23. Inlet needle & seat | 52. Throttle return spring |
| 24. Inlet seat gasket | 53. Anchor/stop pin |
| 25. Diaphragm lever | 54. Throttle shutter |
| | 56. Throttle stop lever |
| | 59. Fuel pump gasket |
| | 60. Fuel pump diaphragm |
| | 61. Fuel pump body |
| | 62. Inlet screen |



Fig. HL236—Cross-sectional view showing proper setting of fuel diaphragm lever (25—Fig. HL235).

MAINTENANCE

SPARK PLUG. A Champion type UJ-7G spark plug is recommended. Set electrode gap to 0.025.

CARBURETOR. Refer to Fig. HL235 for exploded view of Tillotson model HP-19B carburetor. For initial adjustment, open main fuel needle (32) about one turn and idle fuel needle (14) about 1/8-turn. Back idle speed screw (17) out until throttle disc will fully close, then turn screw back in until screw contacts stop plus one additional turn. Make final adjustment with engine running and warm. Adjust idle speed screw so that engine runs at just below clutch engagement speed, then adjust idle fuel needle for smoothest engine operation. With engine running under full load, adjust main fuel needle so that engine runs at highest speed obtainable without excessive smoke.

Fig. HL236 shows proper adjustment of fuel diaphragm lever. Inlet diaphragm lever spring tension will be correctly adjusted when two copper washers (31—Fig. HL235) are used on adjusting screw (30) and screw is tightened down against the washers. Care should be taken when installing main nozzle plug (39) because of minimum amount of thread on plug.

Fig. HL237 — Exploded view showing air cleaner and throttle handle.

- | |
|---------------------------|
| 1. Carburetor gasket |
| 2. Air cleaner elbow |
| 3. Gasket |
| 4. Air filter cover |
| 5. Filter and gasket |
| 6. Throttle handle |
| 7. Choke rod |
| 8. Grommet |
| 9. Throttle trigger |
| 10. Throttle latch spring |
| 11. Throttle latch button |
| 12. Handle cover |
| 13. Throttle shaft |
| 14. Carburetor guard |

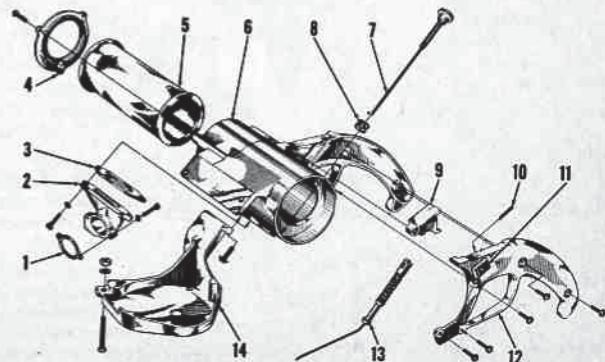

REPAIRS

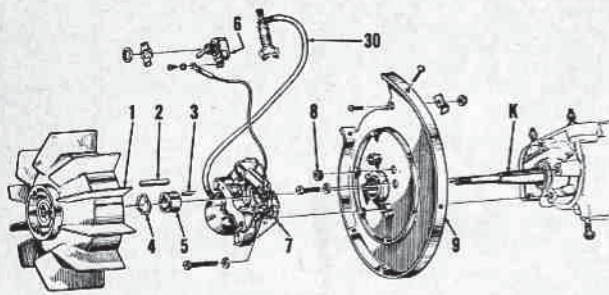

- K. Crankshaft keyway
 1. Magneto rotor
 2. Rotor key
 3. Cam key

4. Wave washer
 5. Breaker cam
 6. "ON-OFF" switch
 7. Coil & breaker assembly

8. Grommet
 9. Back plate
 30. High tension wire

Fig. HL239—View showing magneto rotor, magneto and back plate installation. Breaker cam (5) is removable from crankshaft. Cam key (3) and rotor key (2) both fit in same crankshaft keyway (K). Refer to Fig. HL240 for exploded view of magneto coil and breaker assembly (7).

CONNECTING ROD. Connecting rod and piston unit can be removed from crankshaft after removing cylinder shield and cylinder from crankcase. After disconnecting rod from crankshaft, be sure all of the 31 loose needle rollers are removed from crankcase. To remove piston from connecting rod, remove the retaining snap rings, support piston and bump piston pin from piston and rod.

Check crankpin bearing surfaces in rod and cap and renew rod if surface is scored or shows visible wear. Also, be sure that the Formica thrust washers bonded to each side of rod and cap remain completely bonded and are not excessively worn or grooved. If connecting rod is otherwise serviceable, the needle roller bearing (20—Fig. HL241) can be renewed. To remove old bearing and install new bearing, use Homelite bearing plug (driver) No. A-23809 and support connecting rod on suitable sleeve. Drive or press on lettered end of bearing cage only.

It is recommended that the crankpin needle rollers be renewed at each overhaul. Wrap the strip of 31 rollers around crankpin, then install rod and cap. If reassembling unworn unit, use grease to stick 16 rollers in connecting rod and 15 rollers in cap. Assemble rod to cap with match marks aligned, wiggle rod as screws are tightened to align fractured mating surfaces and tighten screws to a torque of 70-80 inch-pounds.

LUBRICATION. Engine is lubricated by mixing ½-pint of Homelite oil or good grade SAE 30 motor oil with each gallon of regular gasoline (16:1 mixture).

Fill chain oiler tank with Homelite Bar and Chain Oil or with new SAE 30 motor oil. In cold temperatures where motor oil will not pump through chain oiler, dilute oil with one part kerosene to four parts oil.

CARBON. Carbon deposits should be cleaned from the muffler and exhaust ports at regular intervals. Refer to Fig. HL241 for exploded view of muffler. When scraping carbon from exhaust port, be careful not to damage edges of ports. Use a wood scraper.

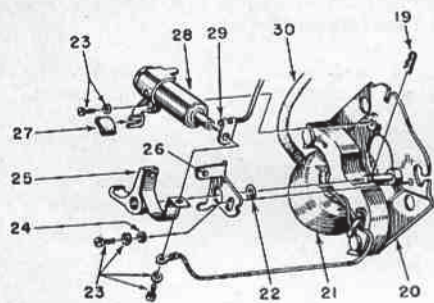

Fig. HL240—Exploded view of magneto coil and breaker assembly.

19. Clip
 20. Armature core
 21. Ignition coil
 22. Washer(s)
 23. Screws
 24. Washer
 25. Breaker arm
 26. Contact plate
 27. Felt wick
 28. Condenser
 29. Switch (ground) lead
 30. High tension wire

GOVERNOR. Engine is equipped with a centrifugal type governor which is a part of the rotary intake valve (16—Fig. HL241). The governor consists of a weighted, spring loaded shutter attached to the rotary valve. When engine speed reaches design limit, the shutter closes off the intake opening in rotary valve plate, thereby governing engine speed. Refer to INTAKE VALVE paragraph in REPAIRS section for service information on the intake valve and governor unit.

IGNITION SYSTEM. Refer to Fig. HL239 for view showing magneto rotor (flywheel), breaker cam, magneto assembly and back plate. Fig. HL240 shows exploded view of magneto. Magneto is accessible after removing recoil starter assembly and crankshaft nut, then pulling rotor from crankshaft using Homelite tool No. AA-22560 puller or equivalent.

Refer to ignition coil test specifications following FUNDAMENTALS section of this manual. Condenser capacity should be 0.16-0.20 mfd. Note that breaker cam (5—Fig. HL239) is installed with side having arrow facing out. Adjust breaker point gap to 0.020. Be sure to reinstall spring (wave) washer (4) between breaker cam and rotor.

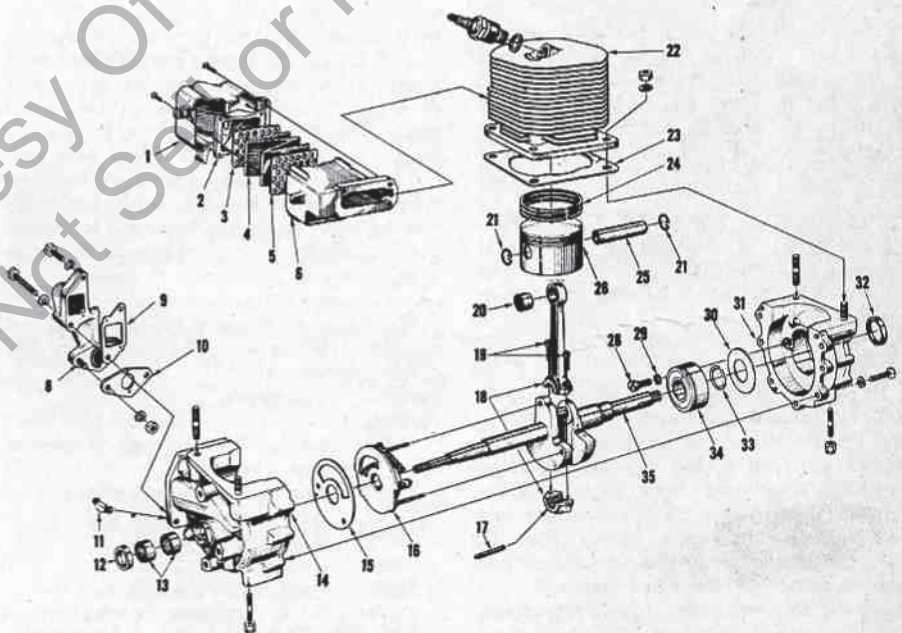

Fig. HL241—Exploded view of 5-30N power head. Fitting (11) connects crankcase pulse passage to carburetor fuel pump diaphragm. Rotary intake valve and governor assembly (16) is driven by crankshaft. Formica wear plate (15) is held stationary in front crankcase half (14).

1. Heat damper
 2. Muffler cap
 3. Outer retainer
 4. Muffler element
 5. Inner retainer
 6. Muffler shell
 8. Intake manifold
 9. Manifold gasket
 10. Carburetor gasket

11. Pulse line fitting
 12. Crankshaft seal
 13. Needle bearings
 14. Front crankcase half
 15. Formica wear plate
 16. Intake valve & governor
 17. Needle rollers (31)

18. Connecting rod & cap
 19. Cap screws
 20. Needle roller bearing
 21. Snap rings
 22. Cylinder
 23. Gasket
 24. Piston rings
 25. Piston pin

26. Piston
 28. Bearing screws
 29. Special washers
 30. Gasket
 31. Rear crankcase half
 32. Crankshaft seal
 33. Snap ring
 34. Ball bearing
 35. Crankshaft

PISTON, PIN AND RINGS. The piston is fitted with three pinned compression rings. Piston ring end gap should be 0.070-0.075; renew rings if end gap is 0.100 or more. Ring width is 0.037 and side clearance in groove is 0.0025-0.0035; renew piston if side clearance of new ring in top groove is 0.004 or more. Also, renew piston if cracked, scored or if worn so that ring locating pin is worn to half of original thickness or there is visible up and down play of piston pin in bore. Piston and pin are available as a matched set only.

When installing piston or piston and rod assembly, be sure that piston ring locating pin is towards intake side of cylinder.

CYLINDER. Cylinder bore is chrome plated. The cylinder is honed after plating; thus, bore does not have the appearance of polished chrome and is light gray in color. If plating has been penetrated by scoring or wear, the soft aluminum underneath will appear as a brighter area than the chrome bore. Usually, the worn areas will be located at edges of the cylinder ports. In some instances, particles from scored piston will adhere to cylinder bore and these deposits can be removed using a rubber impregnated grinding wheel mounted in an electric drill. If a screwdriver tip will not scratch the cleaned surface, cylinder is suitable for further service. If a screwdriver will scratch the cleaned surface or bright areas in cylinder bore indicate plating is worn through, renew the cylinder. Also, renew cylinder if cracked or if more than three critical cooling fins are broken off.

When installing both a new piston and cylinder, clean the parts, lubricate with oil and install piston in cylinder without rings or connecting rod. Piston should slide in bore from its own weight when cylinder is turned on end. If piston sticks, select another piston or cylinder that will give desired fit.

CRANKSHAFT, BEARINGS AND SEALS. The crankshaft is supported by needle roller bearings (13—Fig. HL241) in front crankcase half (14) and by a ball bearing (34) in rear crankcase half (31). Lip type seals (12 & 32) facing towards inside (crankpin) seal crankcase pressure.

To remove crankshaft, proceed as follows: Remove transmission cover, clutch assembly, clutch drum and drive belt. Remove starter assembly, fan housing, flywheel (magneto rotor) and back plate. Remove cylinder and piston and connecting rod unit. Separate crankcase halves, then lift governor shutter away from crankshaft and remove rotary intake valve assembly. Remove the two ball bearing retaining screws (28) and special washers (29), then press crankshaft and ball bearing from rear crankcase half. Remove snap ring (33) and press crankshaft from ball bearing. Remove seals (12 & 32) from crankcase halves and needle roller bearings (13) from front crankcase half.

Reassemble as follows: Install new crankshaft seal (32) in rear crankcase half with seal lip inward. Soak new gasket (30) in oil and position gasket in rear crankcase half. Install ball bearing (34) on crankshaft with groove in outer race towards crankpin

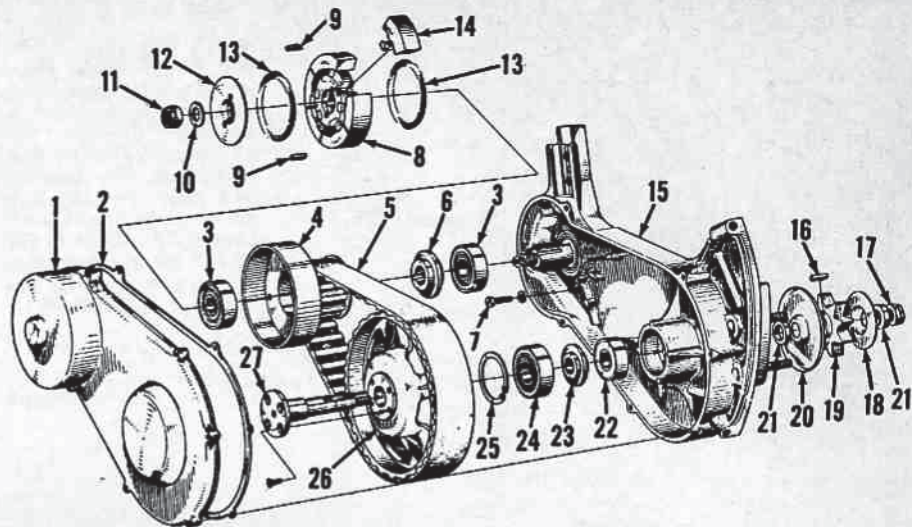

Fig. HL242—Exploded view of clutch and belt drive transmission. Cog belt (5) provides a positive drive on sprockets (4 & 26). All bearings are of sealed, pre-lubricated type. Gasket (2) excludes saw dust from transmission case.

- | | | | |
|-----------------------|---------------------------|-----------------------|---------------------|
| 1. Transmission cover | 7. Hex head screws | 14. Clutch shoe | 21. Spacers |
| 2. Gasket | 8. Clutch spider assembly | 15. Transmission case | 22. Sealed bearing |
| 3. Sealed bearings | 9. Drive keys | 16. Sprocket keys | 23. Spacer |
| 4. Drum & sprocket | 10. Flat washer | 17. Nut | 24. Sealed bearing |
| 5. Cog belt | 11. Crankshaft nut | 18. Outer flange | 25. Snap ring |
| 6. Spacer | 12. Clutch cover | 19. Sprocket | 26. Driven sprocket |
| | 13. Clutch springs | 20. Inner flange | 27. Drive shaft |

and secure bearing with snap ring (33). Using seal protector, jackscrew and adapters, pull crankshaft and bearing into rear crankcase and install new screws (28) and washers (29). Holding governor shutter out so that it will not scratch crankshaft, install intake valve assembly (16) on crankshaft so that springs enter holes in crankshaft throw. Install new needle bearings (13) in front crankcase half, then install new seal (12) with lip towards bearings. Be sure Formica wear plate (15) is positioned properly in front crankcase half and assemble front crankcase half to crankshaft and rear half. Complete remainder of assembly by reversing removal procedures.

The following Homelite special tools are available for servicing the crankshaft and crankcase assembly:

| Tool No. | Description |
|----------|--|
| A-22560 | Rotor puller, also used to push crankshaft from rear crankcase half. |
| 22720 | Rear crankcase seal sleeve. |
| 22764 | Rear crankcase seal tool. |
| 22678 | Ball bearing adapter. |
| A-22680 | Jackscrew. |
| 23176 | Front crankcase half seal tool. |
| 23174 | Front crankcase bearing tool. |

CRANKCASE. Refer to CRANKSHAFT, BEARINGS AND SEALS paragraph for service information covering removal and installation of crankcase halves. With engine disassembled, check to be sure that pulse passage in front crankcase half is open and clean. The passage enters crankcase via intake valve register. Clean passage with a wire if necessary.

Be sure to handle crankcase halves carefully to that mating surfaces are not damaged. Small burrs can be removed by lapping the surface on a flat plate; take care

to remove a minimum amount of material. No gaskets or sealing compound should be placed between the crankcase halves. If main bearing bore in rear half has a lapped appearance, the ball bearing outer race has been turning within the bore and the crankcase rear half should be renewed.

ROTARY INTAKE VALVE. The rotary intake valve and governor assembly (16—Fig. HL241) is driven by the crankshaft; opening in intake valve plate is timed to intake port in front crankcase half (14) to admit fuel and air mixture to crankcase when piston is on upward stroke. With engine running, the governor plate covers intake valve plate opening at a pre-determined speed to limit intake of fuel and air mixture from carburetor, thus govern engine speed at approximately 5500 RPM.

Refer to CRANKSHAFT, BEARINGS AND SEALS paragraph for information on removing and installing the intake valve and governor unit. The assembly should be renewed if sealing face of valve is scored or worn enough to produce a ridge, if spring posts are loose or if valve face has worn enough to expose the spring posts or governor pivot post. Slight scoring of valve face can be corrected by lapping on a lapping plate using a very fine abrasive. Slight scoring of Formica wear plate (15) is permissible. If wear plate is being renewed, it should be soaked in oil for 24 hours prior to installing it. Be sure the wear plate fits the retaining posts in front crankcase half.

CLUTCH. The shoe type clutch assembly (8—Fig. HL242) is mounted on engine crankshaft. If clutch slips under load, check for excessive wear of clutch shoes. If clutch will not disengage with engine at idle speed, check for broken, weak, distorted or improperly installed clutch springs (13).

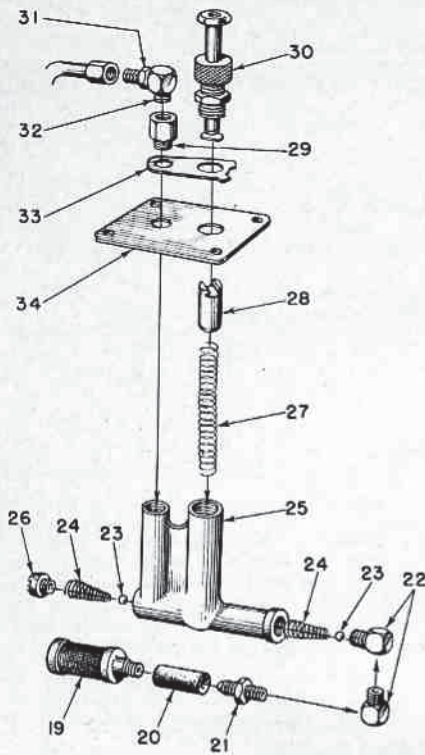

Fig. HL243 — Exploded view of manual chain oiler pump.

- | | |
|------------------------|----------------------|
| 19. Screen | 27. Plunger spring |
| 20. Rubber sleeve | 28. Plunger |
| 21. Fitting | 29. Connector |
| 22. Elbow fittings | 30. Plunger button |
| 23. Check balls | 31. Straight fitting |
| 24. Check ball springs | 32. Elbow fitting |
| 25. Pump body | 33. Locking plate |
| 26. Screw plug | 34. Cover plate |

To remove clutch spider and shoe assembly, remove transmission cover (1), unscrew crankshaft nut (11), remove washer (10) and clutch cover (12), then pull spider and shoe assembly using Homelite tool No. A-22803 or equivalent. To remove clutch drum (4), turn drum and belt while slipping belt off driven sprocket (26). Bearings (3) are sealed and do not require lubrication. Renew bearings if rough or worn and drum is otherwise serviceable. Note: Do not wash the sealed bearings in solvent of any kind. Remove bearing by driving spacer (6) with

Fig. HL244 — Exploded view of the ball drive recoil starter.

1. Pulley cover
2. Starter rope
3. Grip
4. Lock pin
5. Pulley screws
6. Lock washers
7. Rope pulley
8. Dowel pin
9. Plastic shim
10. Crankshaft nut
11. Lock washer
12. Aluminum washer
13. Thrust washers
20. Air screen
21. Recoil spring
23. Spring cover
24. Ball drive plate
25. Steel balls (3)
26. Inner races
28. Ball retainer
29. Ratchet hub
30. Adjusting screw
31. Garlock seals
32. Needle bearings
33. Felt wick
34. Ratchet
35. Formica washer

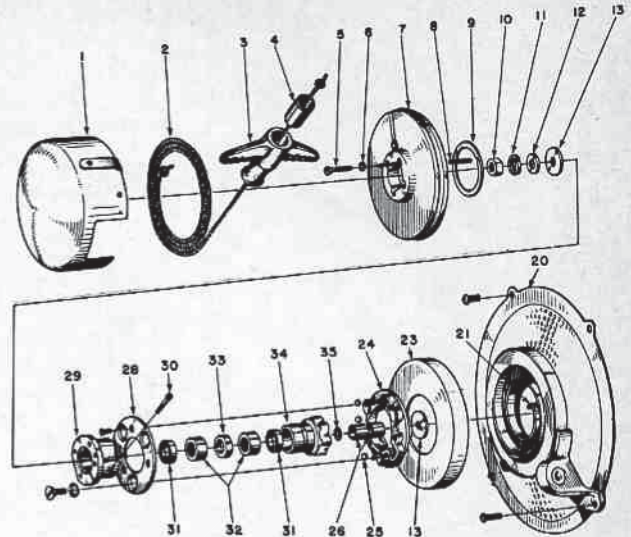

punch to remove one bearing, then drive out opposite bearing. Drive on outer race of new bearing only when installing. Install one bearing flush with inner face of drum, insert spacer, then drive second bearing in flush with face of belt sprocket.

TRANSMISSION. Refer to Fig. HL242 for exploded view of the belt drive transmission. Sealed, pre-lubricated bearings are used throughout and no lubrication is required. Refer to CLUTCH paragraph for removal of clutch, clutch drum and drive belt. To remove driven sprocket, shaft and bearings, proceed as follows:

With saw chain removed, unscrew nut (17) and remove chain sprocket (19) and related parts. Bump shaft (27) and drum from bearings and transmission case. Remove snap ring (25), then drive bearings (22 and 24) and spacer (23) from case.

Clutch drum and sprocket (4) and/or driven sprocket (26) should be renewed if edges of cogs are rounded. Drive belt should be renewed if obviously worn or damaged or if back side of belt can be pushed against transmission case by thumb pressure.

CHAIN OILER PUMP. Refer to Fig. HL243 for exploded view of the manual chain oiler pump assembly. Fig. HL238 shows installation of pump (6) and gasket (7) to chain oil reservoir in fuel tank assembly.

If pump fails to operate properly, check to be sure pick up screen (19—Fig. HL243) is clean and hose (20) is not kinked, collapsed or cracked. Be sure inlet and outlet check valves and springs are in good condition and are properly installed as shown.

STARTER. Refer to Fig. HL244 for exploded view of ball drive recoil starter assembly. Hub (29), which is attached to rope pulley (7) by four screws (5), drives ratchet (34) through friction. Thus, if engine kicks back while cranking, ratchet should slip in hub. Drive torque of hub to ratchet should be 170-180 Ft.-Lbs. and is adjusted by tightening or loosening hub clamp screw (30). Ball drive assembly (items 24 through 35) is retained on engine crankshaft by nut (10). Ball drive plate (24) is attached to flywheel and engine is cranked by steel balls (25) which engage ratchet and ball drive plate. When engine is running, centrifugal force disengages drive balls from ratchet and crankshaft turns in the needle bearings (32) in ratchet. Rewind spring (21) engages pin (8) carried in bores in ratchet and rope pulley.

Crankshaft nut (10), through washers and the two needle bearing inner races (spacers) (26), retain magneto rotor as well as starter assembly to crankshaft. Starter drive torque can be checked using Homelite tool No. A-22224 and a torque wrench.

HOMELITE CAPACITOR DISCHARGE (CD) IGNITION SYSTEM

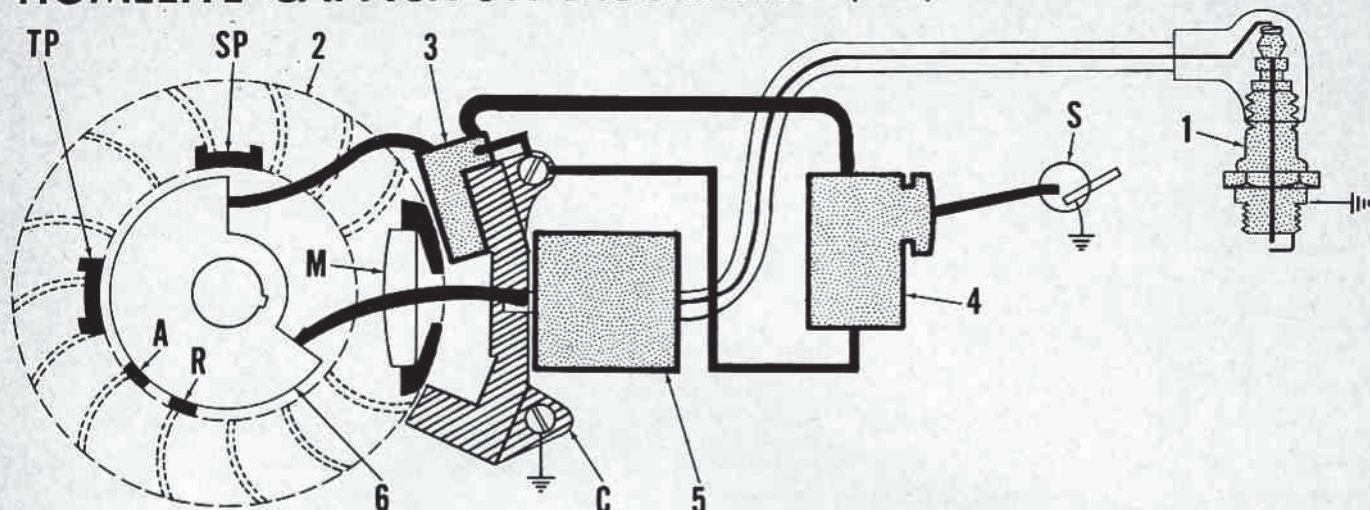

Fig. HL250—Schematic diagram of XL-104 CD ignition system. Electrical energy created by magnet (M) in flywheel (2) passing generator coil (3) and core (C) is stored in the capacitor (4) until SCR switch in timing module (6) is turned on by timing pole piece (TP) passing magnetic triggering device (A or R) in module. The capacitor will then discharge the stored electrical energy into the transformer (5) which builds up the voltage to fire the spark plug (1). SCR switch is actuated by retard magnetic triggering device (R) at cranking speeds and by advance triggering device (A) when engine is running. Safety pole piece (SP) will cause spark plug to be fired on exhaust stroke if engine is turned backwards. "ON-OFF" switch (S) is used to stop engine by grounding the capacitor.

OPERATING PRINCIPLES

The Homelite capacitor discharge ignition system replaces the conventional magneto in that it generates alternating current which is rectified into direct current, the current is stored as electrical energy in a capacitor (condenser) and is discharged on timing signal into the transformer (coil) that steps up the voltage to fire the spark plug. Instead of using breaker points as in a conventional magneto, ignition timing is done by magnetically triggered solid state switch components. Refer to Fig. HL250 for schematic diagram of the model XL-104 capacitor discharge ignition system.

The solid state triggering device is located in a module mounted under the flywheel (rotor). On chain saw models XL-850, XL-875 and XL-904, the capacitor is also located in the module. The capacitor for the model XL-104 ignition system and all other components for all models are mounted outside the flywheel. Ignition system components are as follows:

1. **SPARK PLUG**—A conventional Champion spark plug with a 0.020 firing gap.
2. **FLYWHEEL (ROTOR)**—The CD flywheel is slightly different from breaker ignition flywheels in that it has two pole pieces to trigger the solid state components. One pole piece triggers the switch for normal starting and operating ignition timing and the second pole piece is a safety device to prevent the engine from running backwards. The flywheel magnet passes the generator coil and core to generate electrical current.
3. **GENERATOR**—The generator is an alternator type similar to that used in a battery charging circuit. The generator coil module is a permanently sealed unit mounted on a core. The module generates electrical current to charge the capacitor.
4. **CAPACITOR**—The capacitor stores electrical energy which is discharged into the transformer on signal from the switch module. On the model XL-104, the capacitor is a

sealed unit mounted in a slot in the throttle handle assembly; on other models, the capacitor is sealed inside the switch module.

5. **TRANSFORMER**—The transformer increases the voltage discharged from the capacitor to a voltage high enough to fire the spark plug. The transformer is mounted on the generator core and can be renewed separately.

6. **TIMING SWITCH MODULE**—The timing switch module, which is mounted on the backplate under the flywheel, consists of two magnetic devices which will trigger the silicon controlled rectifier (SCR) switch contained in the module. One magnetic device will trigger the switch for retarded timing at cranking speed and the second will trigger the switch for advanced timing when the engine is running. The advance triggering device is located 16 degrees ahead of the retard device. At cranking speed, the advance triggering device will not generate enough electricity to trigger the SCR switch, but the retard device is stronger and will trigger the SCR switch at cranking speed, thus allowing the electrical energy stored in the capacitor to be discharged into the transformer and fire the spark plug. When the engine is running, the increased speed at which the pole piece in the flywheel passes the advanced triggering device generates enough electrical energy to trigger the SCR switch, thus the capacitor is discharged into the transformer 16 degrees sooner than at cranking speed. When the pole piece passes the retard device, a triggering current is also created, but the capacitor has already been discharged and no ignition spark will occur. Should the engine be turned backwards far enough to charge the capacitor, a second "safety" pole piece in the flywheel will trigger the SCR switch and the spark plug will be fired when the engine exhaust port is open. Thus, when the engine is turned backwards, a "puff" may be heard from the exhaust but a power stroke will not be created.

TESTING THE
CD IGNITION SYSTEM
Model XL-104

Procedure and specifications for checking the capacitor discharge ignition system with a Graham or Merc-O-Tronic tester were not available at time of publication, but a number of tests to indicate condition of the ignition system components can be made using a volt-ohmmeter, preferably a Tripplett or Monarch. To make the volt-ohmmeter tests, refer to Figs. HL251 through HL255 and proceed as follows:

Turn the ignition switch to "ON" position, disconnect lead terminal from spark plug and insert a screw into the terminal. Hold terminal insulating boot to position the screw head 1/4-inch from engine ground and observe for spark while pulling the starter rope. If a spark is observed, the magneto can be considered OK; if no spark is observed, proceed as follows:

CAUTION: Discharge capacitor by switching ignition to "OFF" position or by touching the switch lead to ground if disconnected from switch.

Remove fan housing and flywheel and thoroughly inspect to see that all wires are properly connected and that there are no broken or loose connections. If all wires are secure and in place, make the following tests: Note: Except where rotor is required to be in place during the generator coil test, components may be tested on or off the unit.

Select R₁ scale of ohmmeter and connect one lead of ohmmeter to timing switch module marked "TRANS." and the other lead to terminal marked "GEN." as shown in Fig. HL251. Strike the pole pieces with a screwdriver as shown; the ohmmeter needle should show a deflection and remain deflected until the leads are disconnected. If no deflection is noted, reverse the leads and again strike pole pieces with screwdriver. If no needle deflection is noted with ohmmeter leads connected in either manner, renew the switch module.

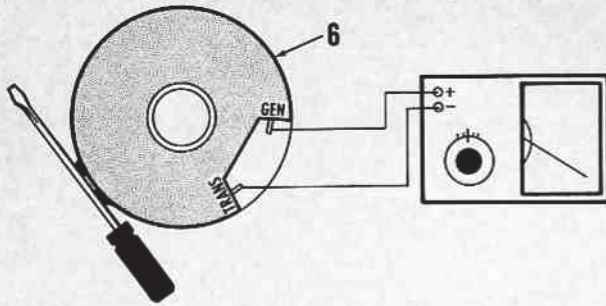

Fig. HL251 — Checking the timing switch module using an ohmmeter; refer to text for procedure.

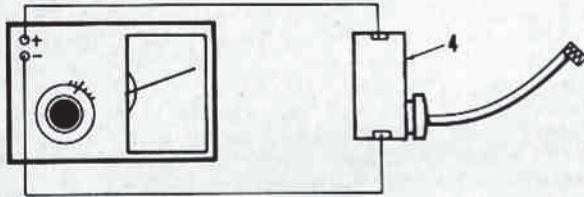

Fig. HL252—View showing ohmmeter connections for checking capacitor; refer to text for procedure.

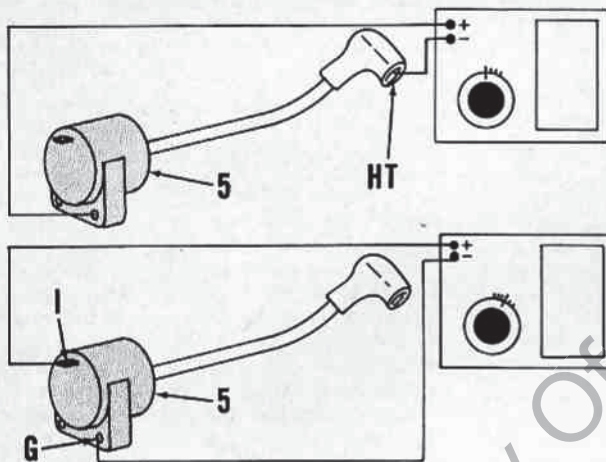

Fig. HL253 — High tension coil of transformer should have between 2400 and 2900 ohms resistance; make ohmmeter connections as shown in top view. Resistance of input coil should be between 0.2 and 0.25 ohms with leads connected as shown in bottom view.

To check capacitor, selection Rx1000 scale of ohmmeter and disconnect ignition switch lead or turn switch to "ON" position. Connect negative (black) lead of ohmmeter to capacitor terminal used for generator coil

lead connection and the positive (red) lead to capacitor ground lead terminal. An instant deflection of needle should occur; if not, reverse ohmmeter leads. If no reflection of ohmmeter needle occurs with leads connected in either direction, renew the capacitor.

Again using Rx1000 scale of ohmmeter, test transformer by connecting either lead of ohmmeter to transformer high voltage lead and other ohmmeter lead to transformer ground; the resulting reading should be between 2400 and 2900 ohms. If proper reading is obtained, disconnect leads, select Rx1 scale of ohmmeter and connect one ohmmeter lead to transformer input terminal and other lead to transformer ground; reading should be between 0.2 and 0.25 ohms. If either reading is not between the desired reading, renew the transformer.

The generator coil (square coil mounted on core) can be checked for continuity as follows: With flywheel removed, disconnect lead from terminal marked "GEN." on switch module. Select Rx1 scale of ohmmeter and connect one lead of ohmmeter to ground and other lead to the lead disconnected from switch module; then, reverse the leads. The ohmmeter should show continuity (by deflection of needle) with the leads connected in one direction, but not in the opposite. If the continuity is not observed in either direction, or if the needle deflects showing continuity in both directions, renew the generator coil. The generator coil can be tested for output by using the voltmeter as follows: Refer to Fig. HL255. Remove spark plug, disconnect lead from ignition switch and bring lead out through switch hole in throttle handle. Disconnect ground lead from capacitor. Select lowest "DC" scale on voltmeter. Connect positive (red) lead of voltmeter to switch wire and the negative (black) lead to engine ground. Spin engine by pulling firmly on starter rope. A minimum of 4 volts should be observed on voltmeter.

It is possible for some capacitor discharge ignition system components to be faulty, but not be detected by the volt-ohmmeter tests. If after testing, a faulty component is not located, renew the components one at a time until the trouble is located. The components should be renewed in the following order:

1. Capacitor
2. Generator coil and core
3. Transformer
4. Timing switch module.

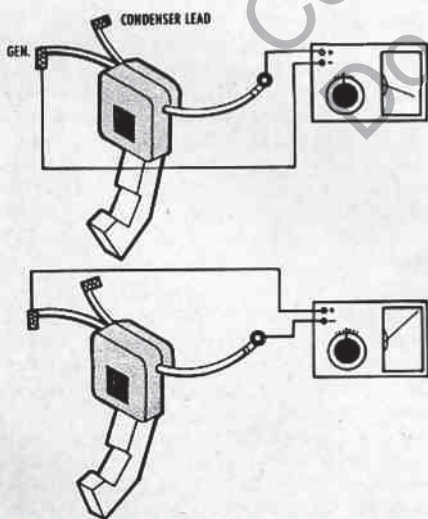

Fig. HL254—Generator coil module should show continuity in one direction only; reversing the leads should cause opposite reading to be observed.

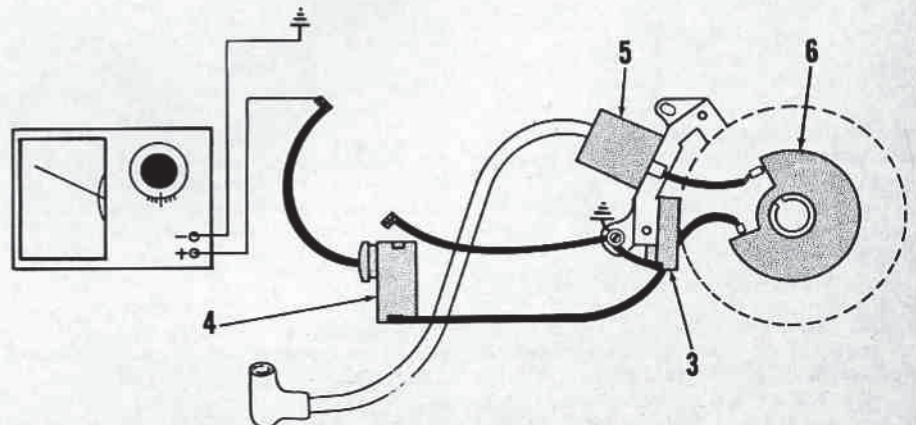

Fig. HL255—Testing output of generator with voltmeter; refer to text for procedure; minimum output should be 4 volts.

HOMELITE

A **Textron** DIVISION

PORT CHESTER, N.Y. U.S.A.

| ENGINE MODEL | Bore | Stroke | Displacement |
|--------------|------|--------|--------------|
| 250 | 2½ | 1¾ | 8.0 |

The model 250 engine is used as power source for centrifugal pumps, diaphragm type pumps, air blowers and generators. The pump, blower or generator must be at least partly disassembled to service some engine components.

MAINTENANCE

SPARK PLUG. Recommended spark plug is a Champion J6J for use on engine powering generator or centrifugal pump; a Champion UJ12 is recommended for use on diaphragm type pump engine. A Champion HO-8A (platinum tip) or UJ-11-G (gold palladium tip) spark plug may be substituted. Electrode gap is 0.025.

CARBURETOR. A Tillotson HS-45A carburetor is used on earlier engines; refer to exploded view of carburetor in Fig. HL1. Note: As engine speed is controlled by governor plate on rotary inlet valve, there are no governor linkage connections to throttle shaft. Throttle shaft has spring loaded detent to hold shaft in wide open position. Generator engine is not fitted with throttle

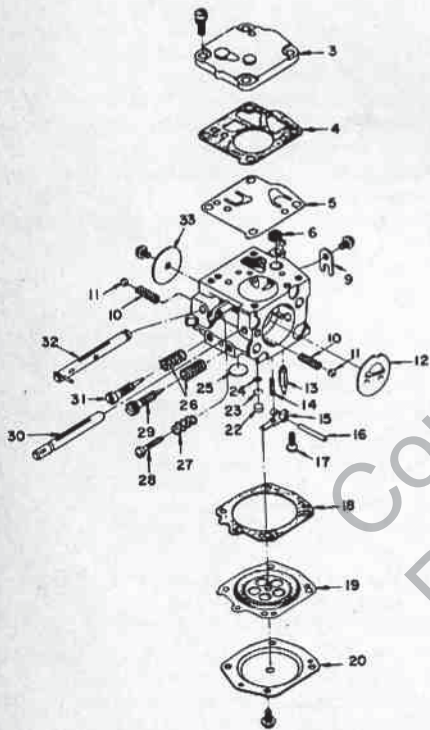
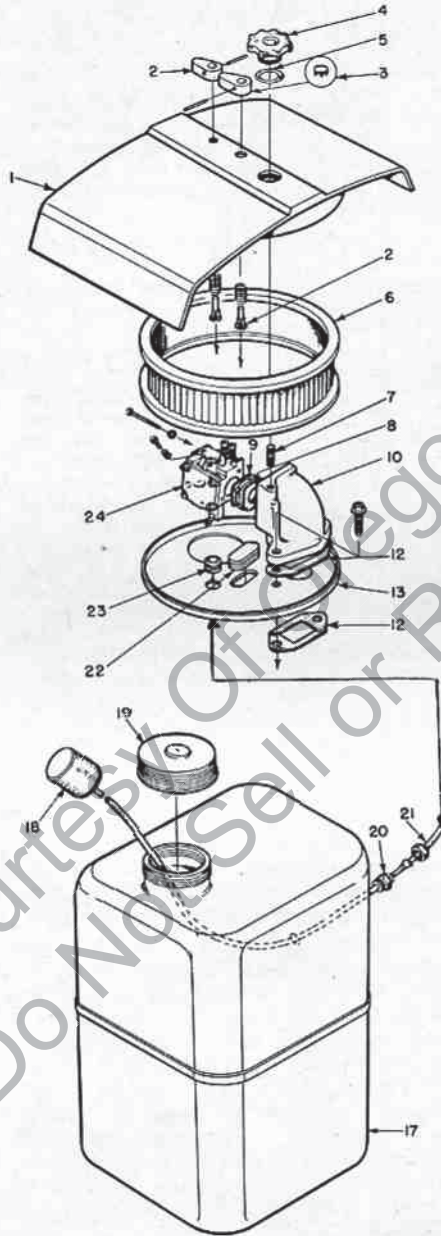

Fig. HL1—Exploded view of Tillotson HS-45A carburetor used on model 250 engine.

- 3. Fuel pump cover
- 4. Fuel pump gasket
- 5. Fuel pump diaphragm
- 6. Inlet screen
- 9. Throttle shaft clip
- 10. Shaft friction springs
- 11. Shaft friction balls
- 12. Choke shutter
- 13. Inlet needle
- 14. Inlet tension spring
- 15. Inlet control lever
- 16. Inlet pinion pin
- 17. Inlet pinion pin retaining screw
- 18. Diaphragm gasket
- 19. Metering diaphragm
- 20. Diaphragm cover
- 22. Welch plug
- 23. Retaining ring for (24)
- 24. Body channel screen
- 25. Welch plug
- 26. Adjusting needle springs
- 27. Idle speed screw spring
- 28. Idle speed screw
- 29. Main adjusting needle
- 30. Choke shaft
- 31. Idle adjusting needle
- 32. Throttle shaft
- 33. Throttle shutter

Fig. HL2—Exploded view of air intake and fuel system. Refer to Fig. HL1 for exploded view of carburetor (24). Control lever and shaft (2) is not used for generator engine and hole is covered by plug (3).

- 1. Air filter cover
- 2. Control shaft assemblies
- 3. Plug (generator only)
- 4. Cover retaining nut
- 5. Nylon washer
- 6. Air filter element
- 7. Stud
- 8. Gasket
- 9. Spacer
- 10. Intake manifold
- 12. Crankcase gasket
- 13. Air filter mounting plate
- 17. Fuel tank
- 18. Fuel filter
- 19. Fuel filler cap
- 20. Fitting
- 21. Fuel line
- 22. Governor adjusting hole plug
- 23. Grommet
- 24. Carburetor assembly

control knob. Carburetor is accessible after removing air cleaner cover (1—Fig. HL2).

Later model carburetor is fitted with a main nozzle check ball which allows use of larger mesh inlet screen (6—Fig. HL1) and provides easier adjustment of fuel mixture. The check ball assembly will be in the same bore as the small body channel welch plug (22), retaining ring (23) and screen (24), and will replace these parts.

When disassembling, slide diaphragm assembly towards adjustment needle side of carburetor body to disengage diaphragm from fuel inlet control lever. To remove welch plugs, carefully drill through plugs with a small diameter drill and pry plugs out with a pin. Caution should be taken that drill bit just goes through welch plug as deeper drilling may seriously damage carburetor. Note channel screen (24) (early model carburetor) and screen retaining ring (23) which are accessible after removing welch plug (22).

Inlet control metering lever (15) should be flush with metering chamber floor of carburetor body. If not, bend diaphragm end of lever up or down as required so that lever is flush.

Normal adjustment of low speed fuel mixture needle (marked "L" on carburetor body) is ¼-turn open and main mixture adjusting needle (marked "H" on carburetor body) should be opened one full turn. On pump or blower engine, back idle speed adjusting screw out until carburetor throttle plate will close fully, then slowly turn screw in until it just contacts pin on throttle shaft, then turn screw in an additional 1½ turns.

Start engine and allow to warm up before making final carburetor adjustments. With carburetor throttle shaft in high speed detent position and engine running under load, adjust main (H) fuel needle for smoothest running. Note: On generators, there is no external control for throttle, thus no need to make idle adjustments. Move throttle shaft to idle speed position and adjust idle fuel needle (L) for smoothest idle. Adjust idle speed stop screw to desired idle speed. If engine will not accelerate from idle speed to full throttle without hesitation, open idle fuel needle an additional ½-turn.

GOVERNOR. The governor is a part of the rotary inlet valve; refer to Fig. HL3. As engine speed increases, centrifugal force pivots governor plate on pivot pin (P) against tension of spring (S). The governor plate then closes the opening in rotary valve and thus throttles the engine. Maximum governed engine speed is controlled by tension of governor spring, which is adjusted by turning screw (A).

To check and adjust engine speed, proceed as follows: First, bring engine to normal operating temperature and adjust carburetor for highest speed and best perfor-

mance obtainable, then check engine speed with tachometer. Refer to the following chart for correct governed speed:

| | No Load RPM | Full Load RPM |
|------------------|-------------|---------------|
| Generator | 3750 | 3600 |
| Centrifugal Pump | 3900-4000 | 3400-3600 |
| Diaphragm Pump | 2800-3000 | 2800-3000 |
| Blower | 3750-3800 | 3400-3600 |

If adjustment is necessary, stop engine and remove air filter cover and rubber plug (22—Fig. HL2) from air filter base (13). Remove brass plug from engine crankcase through opening in filter base and turn engine so that adjusting screw (A—Fig. HL3) is accessible. Then, as shown in Fig. HL4, turn adjusting screw clockwise to increase speed or counter-clockwise to decrease speed. One turn of the screw will change governed speed approximately 100 RPM. Reinstall brass plug, rubber plug and air

filter cover, then recheck engine speed; readjust if necessary.

IGNITION AND TIMING. Breaker points, condenser and ignition coil are accessible after removing engine flywheel (magneto rotor). A hole is provided in magneto back plate and inner face of flywheel so that a pin may be inserted to hold flywheel from turning. Unscrew flywheel nut and remove flywheel using Homelite puller #AA-22560, or equivalent. Tighten puller center screw, then tap screw with hammer to loosen taper fit of flywheel to crankshaft. **CAUTION:** Attempting to remove flywheel by tightening puller screw only may damage flywheel.

To adjust breaker point gap, turn engine so that leading edge of breaker cam is about 1/8-inch past breaker point cam follower, then adjust point gap to 0.020.

NOTE: On earlier models, removal of flywheel (magneto rotor) will also require removal of the fan housing (17—Fig. HL8). Fan housing and magneto back plate are integral on later models; removing starter and starter adapter plate will permit access to remove magneto rotor. Also, service crankshafts may have two keyways for breaker cam and magneto rotor. The second keyway (painted red) is at 2 o'clock position (when considering cylinder at 12 o'clock position) for use with one-piece fan housing and back plate only when breaker points are located above crankshaft. On early engines with two-piece fan housing and back plate, breaker points are mounted below crankshaft (opposite cylinder). The breaker cam and rotor must be positioned in same keyway. The new one-piece fan housing and back plate may be installed on earlier models by tapping the two drilled stator mounting holes and mounting magneto stator (armature and coil) in original position. When both new crankshaft

and fan housing/back plate are used, re-mount magneto stator in new position, use red keyway for installing cam and rotor and mount starter using new adapter plate. New magneto leads, retaining clips and rivets will be required also.

LUBRICATION. Engine is lubricated by oil mixed with fuel. Homelite 2-cycle motor oil is recommended; however, SAE-30 non-detergent motor oil may be used if Homelite oil is not available. Do not use multi-grade oils.

For use in diaphragm pump engine only, mix 1/4-pint of oil with each gallon of gasoline. For all other application, mix 1/2-pint of oil with each gallon of gasoline. Always mix oil and gasoline thoroughly in separate container, then pour mixture into fuel tank.

AIR AND FUEL FILTERS. The air cleaner element may be washed by sloshing it around in a container of non-oily solvent. If engine is run continuously, clean air filter daily. After a number of cleanings, filter pores may become permanently clogged, making it necessary to renew element.

The fuel filter is part of the fuel pick-up inside fuel tank and can be fished out with wire hook. Under normal operations, the filter element should be changed at one to two month intervals. If engine is run continuously, or fuel is dirty, the filter may need to be changed weekly, or more often if necessary.

CARBON. The carbon should be cleaned from the exhaust ports at 100 to 200 hour intervals. Remove muffler, crank piston to top dead center and use a wooden or plastic scraper to remove carbon deposits. Avoid scratching piston or damaging edge of port. **Note:** For easy access to exhaust port, stand engine on recoil starter end.

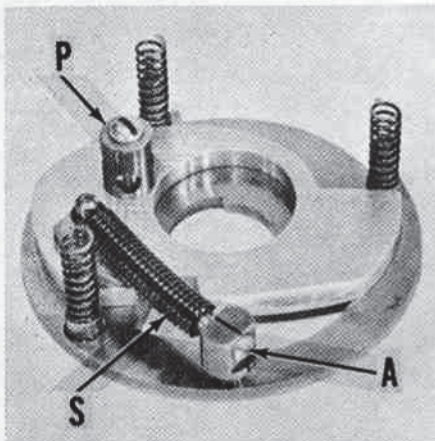

Fig. HL3—View of rotary intake valve and governor assembly. Governor plate pivots on post (P) to close off valve opening in rotary valve plate to govern engine speed. Speed at which plate closes the opening is regulated by tension of governor spring (S) which is adjusted by turning screw (A).

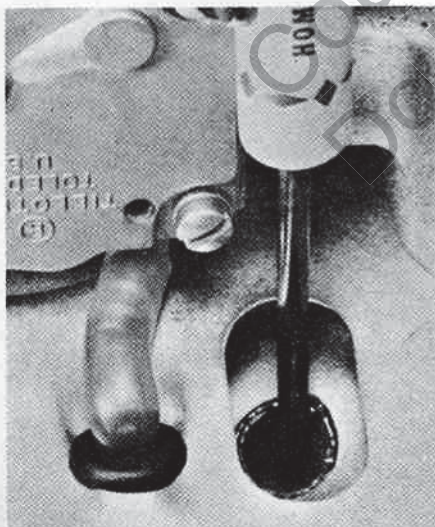

Fig. HL4—Access to governor spring adjusting screw (A—Fig. HL3) is gained by removing air filter cover, rubber plug (22—Fig. HL2) and the brass plug from engine crankcase. Then, turn engine so that screw can be turned with screwdriver as shown.

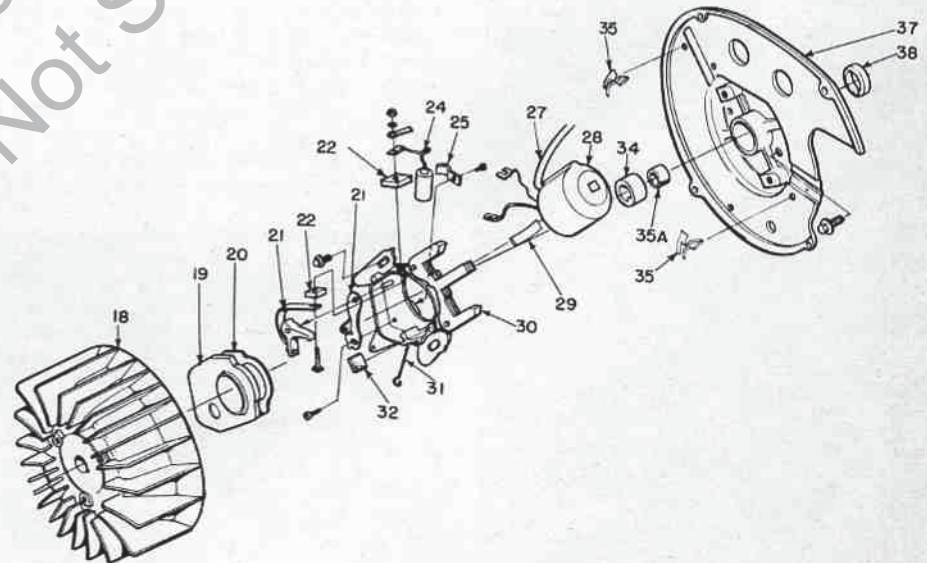
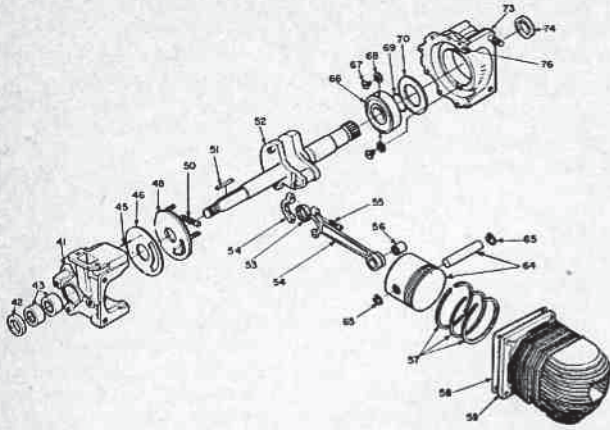

Fig. HL5—Exploded view of model 250 magneto assembly. Magneto components are accessible after removing flywheel; refer to text. A zinc flywheel (magneto rotor) should be used on diaphragm pump engine; other model 250 engines use aluminum flywheel.

- | | | | |
|-------------------------|-----------------------|------------------------------|--------------------------|
| 18. Flywheel | 24. Condenser | 30. Stator & armature assy. | 34. Breaker cam |
| 19. Breaker box cover | 25. Condenser clamp | 31. Breaker box cover spring | 35. Wire retaining clips |
| 20. Gasket | 27. High tension lead | 32. Cam wiper felt | 35A. Felt seal |
| 21. Breaker points | 28. Ignition coil | | 37. Back plate |
| 22. Terminal connection | 29. Coil wedge | | 38. Felt seal |



- | | | |
|------------------------------------|---------------------------------|-------------------------------|
| 41. Crankcase half | 52. Crankshaft (diaphragm pump) | 65. Snap rings |
| 42. Crankshaft seal | 53. Needle bearing rollers (31) | 66. Roller bearing |
| 43. Needle roller bearings | 54. Connecting rod & cap | 67. Bearing retaining screws |
| 44. Dowel pins | 55. Socket head screws | 68. Bearing retaining washers |
| 45. Intake valve wear plate | 56. Needle roller bearing | 69. Snap ring |
| 46. Intake valve & governor assy. | 57. Piston rings | 70. Bearing gasket |
| 48. Intake valve & governor spring | 58. Gasket | 73. Crankcase half |
| 50. Governor spring | 59. Cylinder | 74. Crankshaft oil seal |
| 51. Cam & flywheel key | 64. Piston & piston pin | 76. Dowel pin |

Fig. HL6—Exploded view of 250 engine. Crankshaft end play is controlled by ball bearing (66). Three different crankshafts are used; shaft shown is for diaphragm pump. Crankshaft for generator has tapered end with threaded counterbore for armature retaining bolt. Crankshaft for other applications has externally threaded end.

REPAIRS

CONNECTING ROD. Connecting rod and piston assembly can be removed after removing cylinder from crankcase. Refer to Fig. HL6. Be careful to remove all of the 31 loose needle rollers when detaching rod from crankpin.

Renew connecting rod if bent or twisted, or if crankpin bearing surface is scored, burned or excessively worn. The caged needle roller piston pin bearing can be renewed by pressing old bearing out and pressing new bearing in with Homelite tool Nos. 24131-1 (plug) and 24124-1 (sleeve). Press on lettered end of bearing cage only.

Renew crankpin needle rollers as a set if any roller is scored, burned or has flat spot. Stick needle roller set to crankpin with

heavy grease or beeswax. Using a 10-32 threaded rod or headless screw, position connecting rod or headless screw, position connecting rod cap so that mating boss on cap and connecting rod will align when pinned side of position is on the intake (upper) side of engine; refer to Fig. HL7. Slide connecting rod down over threaded rod or screw, then install socket head screw in opposite side of rod and cap and remove the installation tool. Install remaining socket head screw and tighten both screws to a torque of 32 inch-pounds.

PISTON, PIN AND RINGS. Piston assembly is accessible after removing cylinder assembly from crankcase. Always support piston when removing or installing piston pin. Piston is of aluminum alloy and is fitted with three pinned piston rings.

If piston ring locating pin is worn to half the original thickness, or if there is any visible up and down play of piston pin in piston bosses, renew piston and pin assembly. Inspect piston for cracks or holes in dome and renew if any such defect is noted. Slight scoring of piston is permissible, but if rough surfaces are accompanied by deposit of aluminum on cylinder wall, renew piston.

Always use new piston pin retaining snap rings when reassembling piston to connecting rod. Fit new piston rings in grooves, aligning ring end gaps with locating pin. Be sure locating pin side of piston is away from exhaust side of engine when installing piston and connecting rod assembly.

CYLINDER. Cylinder bore is chrome plated; the plating is light gray in color and does not have the appearance of polished chrome. Renew cylinder if any part of chrome plated bore is worn through; usually, the worn area is bright as the aluminum is exposed. In some instances, particles from the aluminum piston may be deposited on top of chrome plating. This condition is usually indicated by rough, flaky appearance and can be removed by using a rubber impregnated grinding wheel on a 1/4-inch electric drill. If a screwdriver can be run over the cleaned surface without leav-

ing marks thereon, the cylinder is suitable for further service. If screwdriver scratches surface, renew cylinder.

Lubricate piston, rings and cylinder bore. Compress rings, then slide cylinder down over piston. Tighten cylinder retaining nuts evenly and securely.

CRANKSHAFT, BEARINGS AND SEALS. To remove crankshaft, engine must first be removed from blower, pump or generator. Refer to exploded view of appropriate unit in Fig. HL9, HL10, HL11, HL12 or HL13 for required disassembly. Then, refer to Figs. HL5 and HL6 and proceed as follows:

Remove flywheel, magneto assembly and magneto back plate. Remove and discard felt seals (35A & 38—Fig. HL5) from backplate (37). Remove "O" ring oil alinger (not shown) from crankshaft. Remove cylinder, piston and connecting rod assembly, then separate crankcase halves (41 & 73—Fig. HL6). Pull governor weight away from crankshaft, then carefully remove the rotary intake valve and governor assembly (48) to avoid damaging sealing surface of crankshaft. Remove two screws (67) and washers (68) retaining ball bearing (66) in crankcase half (73) and remove shaft and bearing. Tape shaft to prevent scratching sealing surface, then remove snap ring (69) and pull bearing (66) from crankshaft. Remove intake valve plate (46) from crankcase half (41), pry seal (42) out of bore and press needle roller bearing cages (43) out of crankcase half. Remove

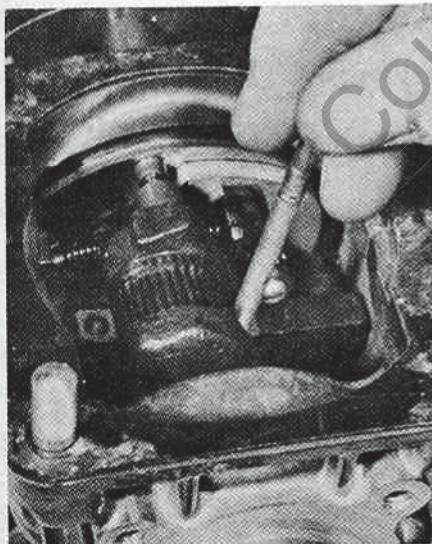

Fig. HL7—A 10-32 threaded rod or headless screw is used as tool to help in assembling connecting rod to cap. Stick the 31 loose needle rollers to crankpin with beeswax or heavy grease, then carefully position cap so that when assembled, pinned side of piston is towards intake side (upper side) of engine.

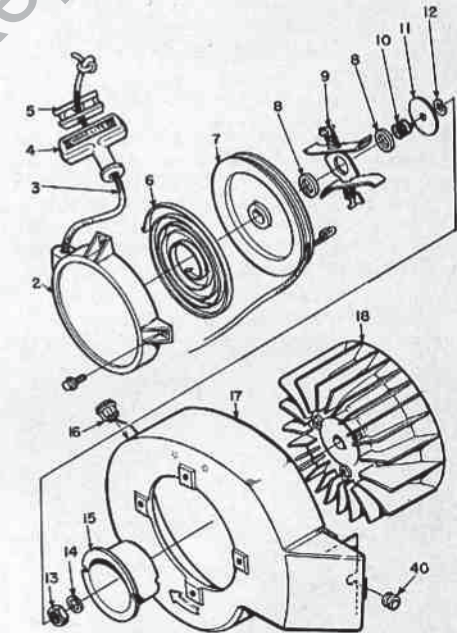

Fig. HL8 — Exploded view of Fairbanks-Morse rewind starter. Starter cup (15) has rope notches so that engine can be started with starter assembly removed. Early type fan housing (17) is shown; later fan housing and magneto back plate (37—Fig. HL5) are integral.

- | | |
|---------------------------|------------------------------|
| 2. Cover & bushing assy. | 11. Brake retaining washer |
| 3. Starting cord | 12. Snap ("E") ring |
| 4. Starting cord grip | 13. Flywheel nut |
| 5. Insert | 14. Lock washer |
| 6. Rewind spring | 15. Starter cup |
| 7. Starter pulley | 16. Engine stop switch |
| 8. Fiber washer | 17. Blower housing |
| 9. Friction shoe assembly | 18. Flywheel (magneto rotor) |
| 10. Brake spring | 40. Grommet |

seal (74) from opposite half. Note: Remove bearings from crankshaft and flywheel side crankcase half only if renewal is indicated.

Renew crankshaft if it has damaged threads, enlarged keyways, or if run out exceeds 0.003. Inspect drive gear on output end of diaphragm pump engine for wear or other tooth damage. Flywheel end main journal must be free of pits, galling or heavy score marks. If journal is worn or out of round more than 0.001, renew crankshaft. Renew ball bearing at output end if bearing

shows perceptible wear or feels rough when rotated. The caged needle roller bearings at flywheel end should be renewed if any roller shows visible flat spot, or if rollers in either cage can be separated more than the width (diameter) of one roller.

When reassembling, soak new bearing gasket (70) in oil, then insert in crankcase half (73). Support crankshaft at throw, then press new ball bearing onto shaft and secure with snap ring (69). Note: Be sure that groove in outer bearing race is towards

crankshaft throw. Lubricate seal (74), then using suitable installation tool (Homelite No. 24120-1 or equivalent) press seal into crankcase half with lip of seal inward. Pressing against outer race of bearing (66) only, install crankshaft and bearing assembly into crankcase half (73) and secure with the two screws (67) and washers (68). Note: Use suitable seal protector (Homelite Nos. 24125-1, 24126-1 or 24127-1, or equivalent) to prevent damage to seal.

Using Homelite tool No. 24155-1, press outer needle bearing into crankcase half (41) with stepped end of tool, then press inner bearing into crankcase half with straight end of tool. Note: Press on lettered side of bearing cage only. Install seal (42) with lip in towards needle bearing with straight end of bearing installation tool.

Fit governor and rotary intake valve assembly onto crankshaft so that thrust springs fit into proper bores of crankshaft. Note: Hold governor plate away from crankshaft when installing to prevent scratching seal surface. Lubricate all parts thoroughly and insert intake valve plate (46) in crankcase half (41) so that it is properly positioned on dowel pins and intake opening. Using seal protector (Homelite No. 24121-1 or equivalent), assemble the crankcase half over crankshaft and governor assembly, hold assembly together against thrust spring pressure and install crankcase cap screws. Tighten cap screws to a torque of 80 inch-pounds. Insert new felt seal (38—Fig. HL5) in bore of magneto back plate, place new "O" ring oil slinger on crankshaft and install back plate. Tighten backplate retaining cap screws to a torque of 80 inch-pounds. Complete reassembly by reversing disassembly procedure.

CRANKCASE. Be sure that all passages through crankcase are clean. The idle passage line which enters crankcase via the intake valve register may be restricted with carbon deposits.

If main bearing bore at output end has a lapped appearance, bearing has been turning in bore, in which instance crankcase half should be renewed. The mating surfaces of the two-piece crankcase must be free of all nicks and burrs as neither sealing compound nor gaskets are used at this joint. NOTE: Fuel tank bracket mounting screws are secured in engine crankcase with Loctite. When reinstalling bracket, clean the screw threads and threads in crankcase, then apply a drop of Loctite to each screw. Tighten screws to a torque of 120 inch-pounds.

ROTARY INTAKE VALVE. The combination rotary intake valve and governor (see Fig. HL3) should be renewed if any of the following conditions are noted: If the sealing faces of valve or governor plate are worn or scored enough to produce a ridge; if spring post is loose or extended to valve seating surface; or, if governor pivot point has started to wear through the surface of valve. Maximum allowable clearance between governor plate and intake valve plate is 0.006. The governor spring and/or governor spring adjusting screw may be renewed separately from the assembly.

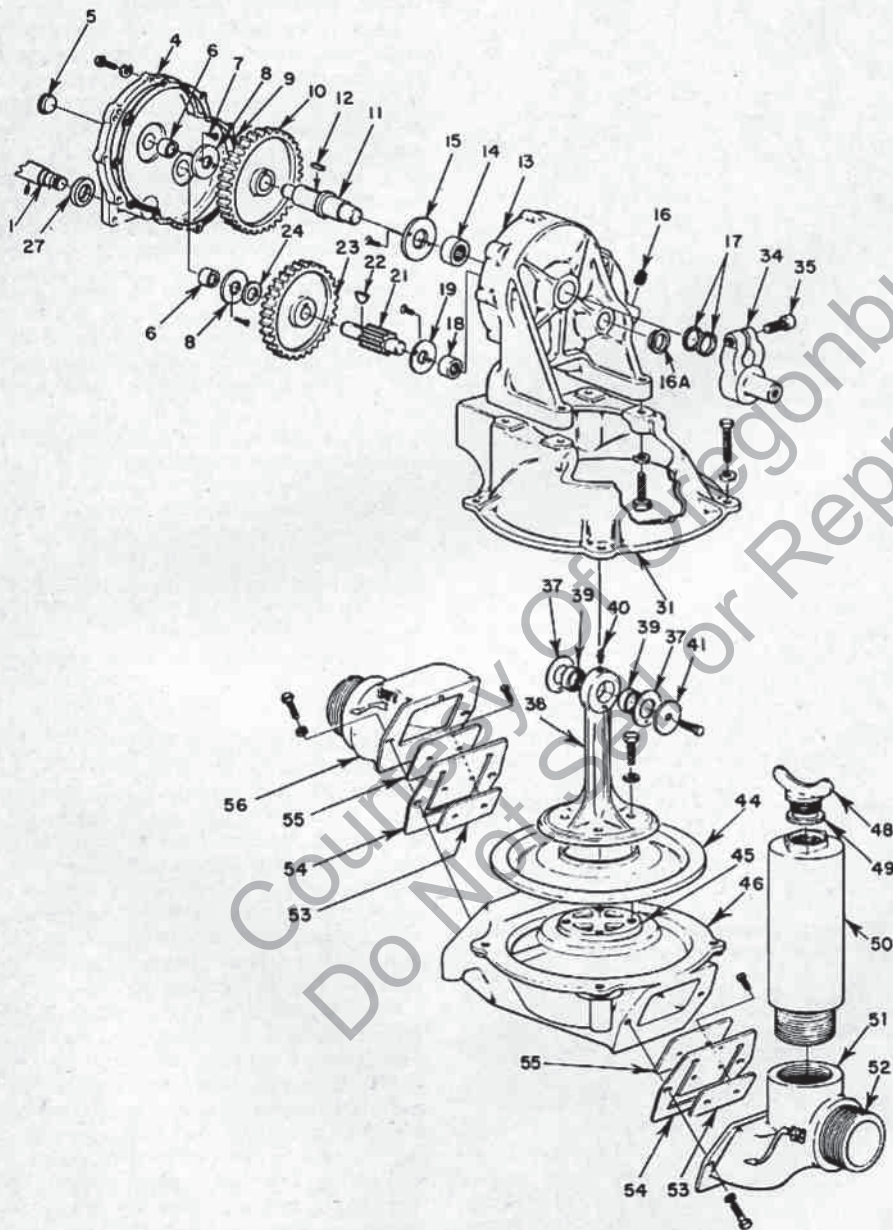
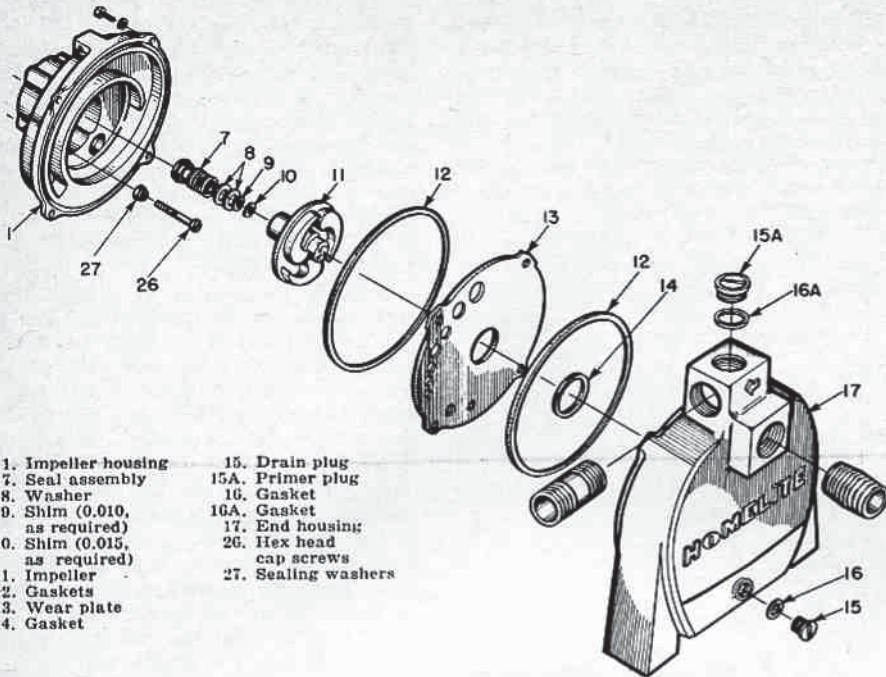

Fig. HL9—Exploded view of diaphragm pump assembly. Gear teeth on engine crankshaft (1) engage intermediate gear (23). Gearcase cover (4) must be removed from pump so that engine can be separated from cover. When installing diaphragm (44), push rod (38) all the way down before installing upper body (31) to lower body (46) bolts.

- | | | | |
|-----------------------|------------------------|-----------------------|-----------------------|
| 1. Engine crankshaft | 14. Needle bearing | 24. Spacer | 46. Pump body |
| 4. Gearcase cover | 15. Thrust washer | 34. Crank | 48. Wing plug |
| 5. Bearing cap | 16. Oil filler plug | 35. Cap screw | 49. Gasket |
| 6. Needle bearing | 16A. Bearing cap | 37. Thrust washers | 50. Standpipe |
| 8. Thrust washer | 17. Garlock seals | 38. Pump rod assembly | 51. Suction fitting |
| 9. Gasket | 18. Needle bearing | 39. Needle bearings | 52. Pipe nipple |
| 10. Pump gear | 19. Thrust washer | 40. Grease fitting | 53. Valve weight |
| 11. Shaft & key assy. | 21. Intermediate shaft | 41. Washer | 54. Valve |
| 12. Key | 22. Woodruff key | 44. Pump diaphragm | 55. Valve plate |
| 13. Gearcase assembly | 23. Intermediate gear | 45. Diaphragm cap | 56. Discharge fitting |



- | | |
|-------------------------------|-------------------------|
| 1. Impeller housing | 15. Drain plug |
| 7. Seal assembly | 15A. Primer plug |
| 8. Washer | 16. Gasket |
| 9. Shlm (0.010, as required) | 17. End housing |
| 10. Shim (0.015, as required) | 26. Hex head cap screws |
| 11. Impeller | 27. Sealing washers |
| 12. Gaskets | |
| 13. Wear plate | |
| 14. Gasket | |

Fig. HL10—Exploded view of centrifugal pump. End housing (17) and impeller (11) must be removed to allow removal of the four cap screws retaining impeller housing (1) to engine. Hold flywheel from turning with pin (see magneto section) to unscrew impeller.

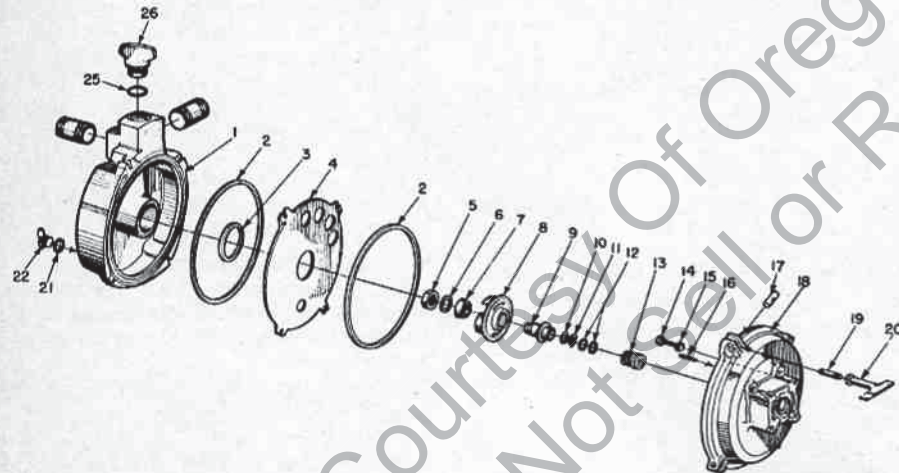

Fig. HL11—Exploded view of trash pump. End housing and impeller must be removed from impeller housing to allow housing to be unbolted from engine.

- | | | | |
|-----------------|-------------------------------|-------------------------------|----------------------|
| 1. End housing | 7. Tapered bushing | 11. Shim (0.015, as required) | 16. Spiral pin |
| 2. Gasket | 8. Impeller | 12. Spacer washers | 17. Pivot pin |
| 3. Gasket | 9. Impeller hub | 13. Seal assembly | 18. Impeller housing |
| 4. Wear plate | 10. Shim (0.010, as required) | 14. Cap screws | 19. Studs |
| 5. Impeller nut | | 15. Sealing washers | 20. Wing nuts |
| 6. Washer | | | |

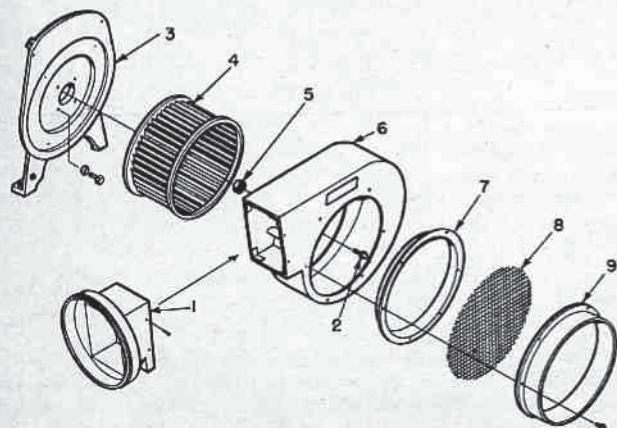

Fig. HL12 — Exploded view of blower unit. Remove blower housing and rotor to allow unbolting and removal of blower plate (1) from engine.

- | |
|-------------------------|
| 1. Blower outlet |
| 2. Slotted head screws |
| 3. Mounting plate |
| 4. Blower rotor |
| 5. Elastic stop nut |
| 6. Blower housing |
| 7. Blower inlet venturi |
| 8. Inlet screen |
| 9. Inlet collar |

Slight scoring of valve face may be corrected by lapping on a lapping plate using a very fine abrasive. Lapping motion should be in the pattern of a figure eight to obtain best results. Slight scoring of the Formica wear plate is permissible. Homelite recommends soaking a new Formica plate in oil for 24 hours prior to installation.

REWIND STARTER. Refer to Fig. HL8 for exploded view of the Fairbanks-Morse starter used on all applications. In an emergency in case of rewind starter failure, remove starter assembly and wind rope around starter cup (15) to start engine.

Refer to exploded view for proper reassembly of starter unit. Hook end of starter rope in notch of pulley and turn pulley five turns counterclockwise, then let spring wind rope into pulley for proper spring pre-tension.

To remove starter cup, insert lock pin through hole in magneto back plate and hole in flywheel to hold flywheel from turning, then unscrew retaining nut.

DIAPHRAGM PUMP. The diaphragm pump is lubricated by filling gearcase to level of plug (16—Fig. HL9) with SAE 90 gear lubricant and by greasing pump rod upper bearing at fitting (40) once a month with pressure gun.

When installing new diaphragm (44) or assembling upper pump body (31) to lower body (46), the diaphragm must be centered and in fully down position before tightening upper body to lower body bolts.

To remove pump from engine, drain gear lubricant and separate gearcase (13) from gearcase cover (4). Gear teeth are machined on end of engine crankshaft to drive intermediate gear (23). Unbolt and remove cover (4) from engine crankcase. When reassembling, use new gasket (9).

CENTRIFUGAL PUMP. Refer to Fig. HL10. To remove pump from engine, remove end housing (17) and wear plate (13) from impeller housing (1), taking care not to damage sealing gaskets. Unscrew impeller (11) from engine crankshaft in counter-clockwise direction by placing wrench on hex end of impeller and striking wrench a sharp blow with hammer. Take care not to lose or damage seals or shims. Impeller housing can now be unbolted from engine.

When reassembling pump, shims (9 and 10) are available to maintain minimum clearance between impeller and wear plate (13). When shims are added to decrease clearance, seal shims (not shown) of the same thickness must be added to spacer washer (8); thickness to maintain proper tension on seal spring. Before reassembling pump, hold wear plate (without gasket) against impeller housing and turn engine by hand to be sure impeller does not rub against wear plate.

TRASH PUMP. The trash pump (Fig. HL11) impeller (8) is mounted on tapered bushings so that if a solid object lodges in pump, the shaft can spin in impeller.

To remove pump from engine, remove end housing (1) and wear plate (4), then unscrew impeller retaining nut (5) and remove impeller (8), taking care not to damage or lose seal and shims (10, 11 & 12). Unbolt

and remove impeller housing (18) from engine.

When reassembling pump, use shim (10 & 11) thickness as required to maintain minimum clearance between impeller and wear plate. Shims are placed between shoulder on crankshaft and impeller hub (9). Install same thickness of seal shims along with spacer washers (12) to maintain seal spring tension.

GENERATOR. Exploded view of generator is shown in Fig. HL13. Care should be taken in disassembly of the generator that any leads disconnected should be identified so they may be reconnected properly. Also, if brushes are to be reinstalled, they should be identified so they can be installed in same location and position from which they were removed. Carefully disassemble to avoid damage to wiring or insulation.

Generator rotor (4) is removed from crankshaft after removing retaining cap screw (17) by inserting a pin (Homelite No. 22271 cut to length of $4\frac{1}{2}$ inches measured from tapered end), tapered end first, and breaking taper fit loose with jackscrew (Homelite tool No. S-394) threaded into end of rotor shaft. Generator end bell (5) can then be removed from engine.

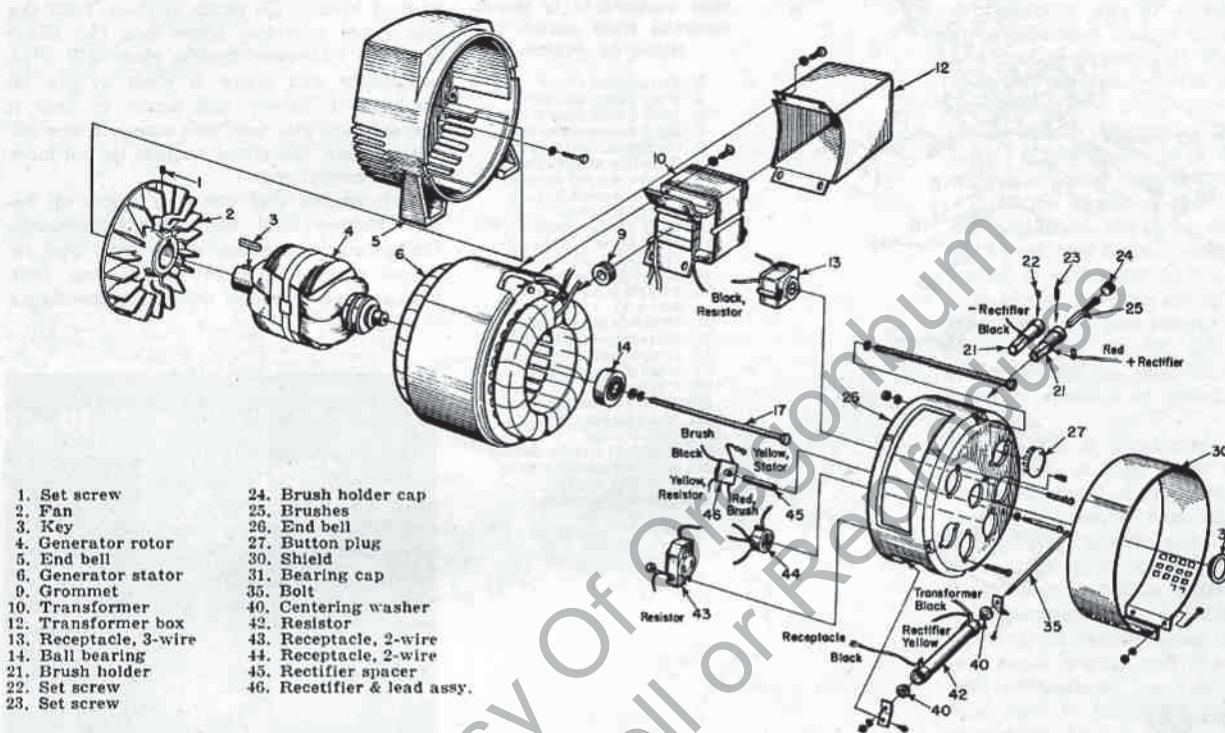

Fig. HL13—Exploded view of generator unit. The through bolt (17) retains generator rotor (4) on tapered end of engine crankshaft. After removing rotor and fan (2) assembly from engine crankshaft, the fan housing end bell (5) can be unbolted from engine crankcase.

HOMELITE
A **Textron** DIVISION
PORT CHESTER, N.Y. U.S.A.

| ENGINE MODEL | Bore | Stroke | Displacement |
|--------------|-----------------|-----------------|--------------|
| 251 | 2 $\frac{3}{4}$ | 3 $\frac{1}{8}$ | 12.62 |

The 251 engine is used as power source for Homelite models 251 A35 and 251 HY35 generators, model 251 S3 centrifugal pump and model 251 TP3 trash pump. The generator or pump must be at least partly disassembled to service some engine components.

MAINTENANCE

SPARK PLUG. Either a Champion J6J, HO-8A or UJ-11-G spark plug may be used. The Champion HO-8A platinum tip or UJ-11-G gold palladium tip plug will provide longer service as well as longer intervals between cleanings. Electrode gap is 0.025.

CARBURETOR. Refer to Fig. HL20. The Tillotson Series HL carburetor can be removed from engine by removing air intake manifold (4—Fig. HL21) and air cleaner assembly as the two manifold bolts also retain carburetor and reed valve assemblies. When disassembling carburetor, slide diaphragm assembly towards adjustment needle

side of carburetor body to disengage diaphragm from fuel inlet control lever. To remove welch plug (29—Fig. HL20), carefully drill through plug with a small diameter drill and pry plug out with a pin. Caution should be taken that drill bit just goes through welch plug as deeper drilling may seriously damage carburetor. Note channel

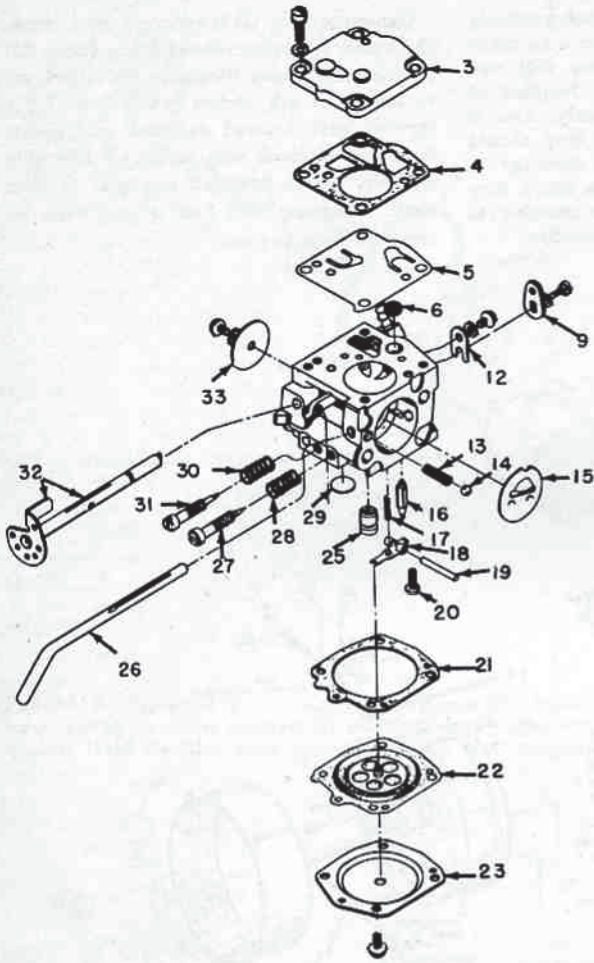

Fig. HL20 — Exploded view of Tillotson Series HS carburetor used on model 251 engine. Note that carburetor is shown inverted from actual position on engine.

- 3. Fuel pump cover
- 4. Fuel pump gasket
- 5. Fuel pump diaphragm
- 6. Inlet channel screen
- 9. Governor spring arm
- 12. Throttle shaft clip
- 13. Choke detent spring
- 14. Choke detent ball
- 15. Choke shutter
- 16. Inlet needle valve
- 17. Inlet lever spring
- 18. Inlet control lever
- 19. Lever pinion pin
- 20. Pinion pin retaining screw
- 21. Diaphragm gasket
- 22. Metering diaphragm
- 23. Diaphragm cover
- 25. Nozzle check valve
- 26. Choke shaft
- 27. Main adjusting needle
- 28. Main needle spring
- 29. Welch plug
- 30. Idle fuel needle spring
- 31. Idle adjusting needle
- 32. Throttle shaft
- 33. Throttle shutter

screen (6) and check valve assembly (25) located in bores of carburetor body.

Inlet control metering lever (18) should be flush with metering chamber floor of carburetor body. If not, bend diaphragm end of lever up or down as required so that lever is flush.

Normal adjustment of low speed fuel mixture needle (marked "LO" on air inlet manifold or needle nearest throttle shaft) is one turn open and main mixture adjustment needle (marked "HI" on air inlet manifold or needle nearest choke shaft) should be opened 3/4-turn. On pump engines, back the idle speed adjusting screw (see Fig. HL22) out until carburetor throttle plate will close completely and screw is clear of pin on throttle rod. Slowly turn screw in until it just contacts pin, then turn screw in one additional turn. Generator engines do not have throttle control rod.

Start engine and allow to warm up before making final carburetor adjustments. On generator engines, apply load and re-adjust main needle so engine runs best, then remove load and adjust idle needle for

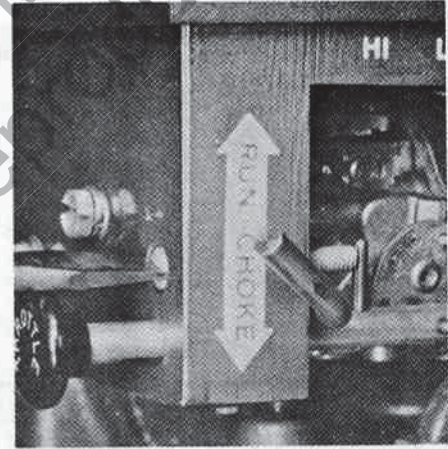

Fig. HL22—Adjusting idle speed screw. Throttle rod friction screw is just visible at under side of air intake manifold. Idle speed must not be adjusted to above 2500 RPM.

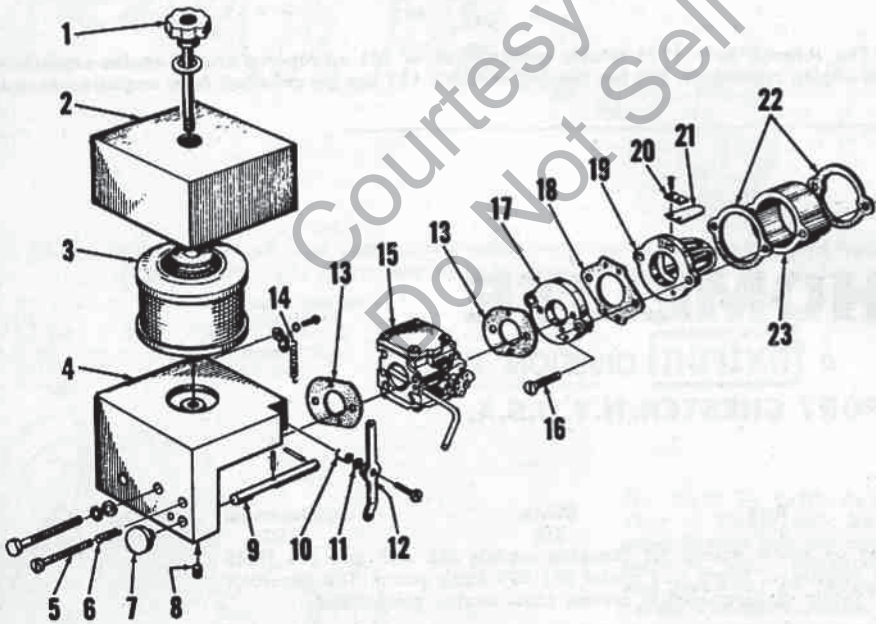

Fig. HL21—Exploded view of air intake manifold (4), air filter element (3) and cover (2), carburetor assembly (15), reed type intake valve and related parts. Throttle control rod (9) and knob (7) are not used on generator engines. Refer to Fig. HL20 for exploded view of carburetor.

- 1. Filter cover knob
- 2. Filter cover
- 3. Air filter element
- 4. Air intake manifold
- 5. Idle speed screw
- 6. Idle speed screw spring
- 7. Throttle (idle) knob
- 8. Throttle rod friction screw
- 9. Throttle rod
- 10. Spacer
- 11. Flat washer
- 12. Bellcrank
- 13. Gaskets
- 14. Governor spring
- 15. Carburetor assembly
- 16. Flat head screws
- 17. Spacer
- 18. Gasket
- 19. Reed valve seat
- 20. Reed clamp
- 21. Reed valve
- 22. Gaskets
- 23. Heat dam

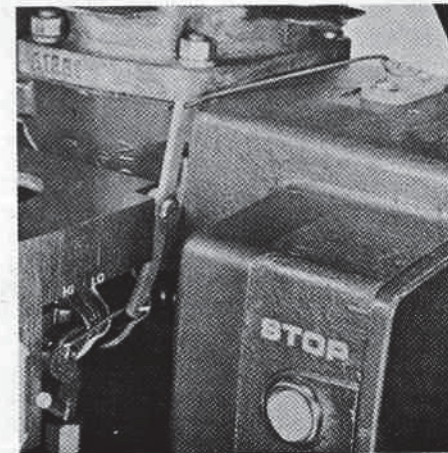

Fig. HL23—View showing proper installation of governor bellcrank and links. Generator engine not equipped with throttle (idle control) rod is shown.

smoothest operation. On pump engines, pump water with throttle control rod pushed all the way in and readjust main mixture needle so engine runs best. Then, lift suction hose out of water, pull throttle rod out and adjust low idle speed for smoothest running. If necessary, readjust idle speed screw to obtain a slow idle speed of 1800-2500 RPM. CAUTION: Do not adjust low idle speed higher than 2500 RPM; higher idle speed will result in damage to governor. Note: The main and idle speed mixture adjustments are interdependent so that changing one needle

setting often requires readjustment of other needle.

When reinstalling carburetor, be sure governor link is connected as shown in Fig. HL23.

GOVERNOR. Engine is equipped with a flyweight type governor mounted on engine crankshaft; refer to Fig. HL24 for exploded view showing governor unit. External governor linkage is shown in Fig. HL23.

CAUTION: Never move governor linkage manually, or exert any pressure on lever or linkage to increase engine speed. Working

governor linkage manually, even momentarily, may cause damage to governor cup and cam due to friction and burning. Also, on pump engines, do not adjust slow idle speed above 2500 RPM.

Maximum-no-load speed for pump engines should be 3800-3900 RPM and for generator engines, should be about 3750 RPM; generator engine speed under load should be 3600 RPM. If necessary to readjust governor, first remove the cover plate (43—Fig. HL24) and slightly loosen governor shaft guide (36) retaining screws. Note that screw hole in guide at carburetor side is slotted; insert screwdriver between side of guide and shoulder machined in housing (45). Pry carburetor side of guide towards cylinder to decrease governed speed or away from cylinder to increase speed. Adjustment provided by total length of slot will change the engine maximum governed speed about 1000 RPM.

If engine governed speed cannot be properly adjusted, check for wear on governor shaft cam and inspect governor spring connected to carburetor throttle shaft.

To renew governor spring (32), cup (31) or back plate (25), first remove starter, magneto rotor (49) and housing (45); the snap ring (34) can then be removed from crankshaft allowing removal of spring, cup and back plate.

IGNITION. A breakerless solid state ignition system is used. Refer to Fig. HL24 for exploded view of the magneto (items 49 through 65) and to Figs. HL25 and HL26.

To check the solid state magneto, disconnect spark plug wire and remove spark plug. Insert a bolt or screw in spark plug wire terminal and while holding bolt or screw about 1/4-inch away from engine casting, crank engine and check for spark as with conventional magneto. If no spark occurs, refer to following inspection and test procedure:

Visually check for broken or frayed wires which would result in open circuit or short. Be sure stop switch is not permanently grounded. Inspect magneto rotor (49), trigger coil (52) and the switch box, condenser and magneto cover assembly (62) for visible damage.

To test magneto components, remove starter assembly, magneto cover and disconnect leads as shown in Fig. HL26, then proceed as follows:

To test ignition coil, refer to test instrument instructions; readings for Graham

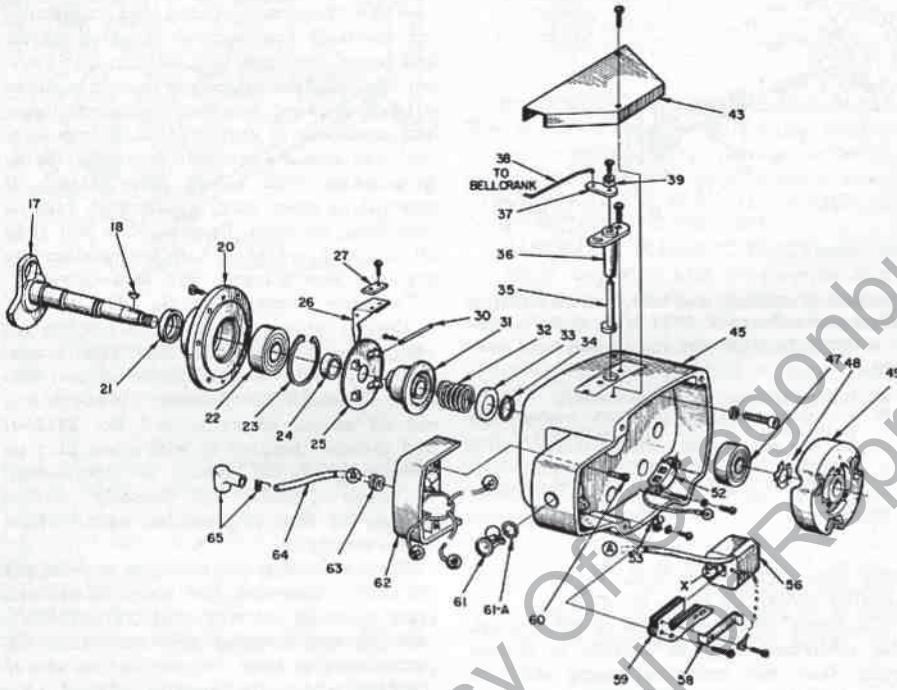

Fig. HL24—Exploded view showing magneto end of crankshaft (17), governor and magneto assemblies. The housing (45) retaining socket head screws can be removed by working through notches in outside of magneto rotor (49) allowing all parts to be removed as a unit after removing governor linkage and disconnecting spark plug wire.

- | | | | |
|-----------------------------|-----------------------|----------------------------|---|
| 17. Crankshaft, magneto end | 27. Governor weight | 39. Flat washer | 60. Cover retaining screw |
| 18. Woodruff key | 30. Weight pivot pin | 43. Governor linkage cover | 61. Stop switch |
| 20. Bearing housing | 31. Governor cup | 45. Magneto housing | 61A. "O" ring |
| 21. Crankshaft seal | 32. Governor spring | 47. Bearing | 62. Magneto cover assembly (includes condenser and solid state switchbox) |
| 22. Bearing | 33. Spring retainer | 48. Loading spring | 63. Grommet |
| 23. Snap ring | 34. Snap ring | 49. Magneto rotor | 64. Spark plug wire |
| 24. Spacer | 35. Governor camshaft | 52. Magneto trigger coil | 65. Spark plug terminal |
| 25. Governor back plate | 36. Camshaft guide | 53. Lead clamp | |
| 26. Governor weight | 37. Governor arm | 56. Ignition coil | |
| | 38. Bellcrank link | 58. Coil spring clip | |
| | | 59. Armature core | |

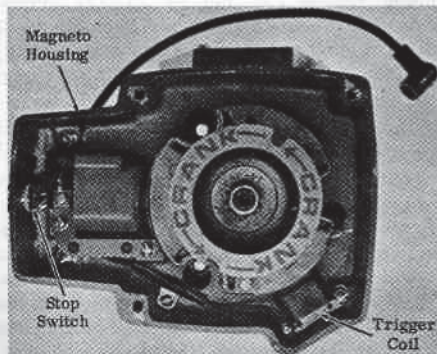
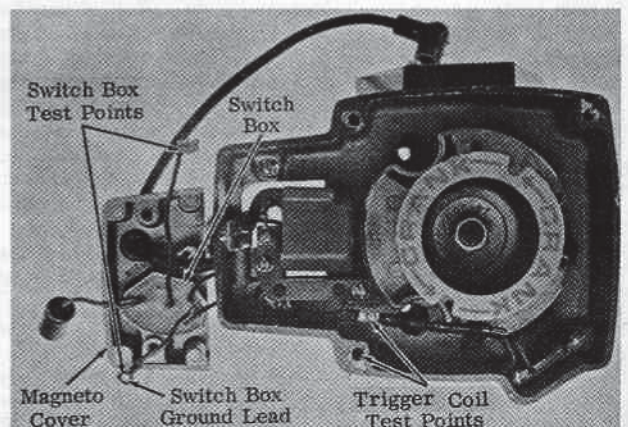

Fig. HL25—View of magneto assembly with rewind starter assembly removed. Armature to magneto rotor air gap and trigger coil to rotor air gap should be adjusted using a 0.0075 thick plastic shim.

Fig. HL26—View showing magneto leads disconnected for testing purposes. Condenser must not touch any other part of the unit. Refer to text for procedure and specifications.



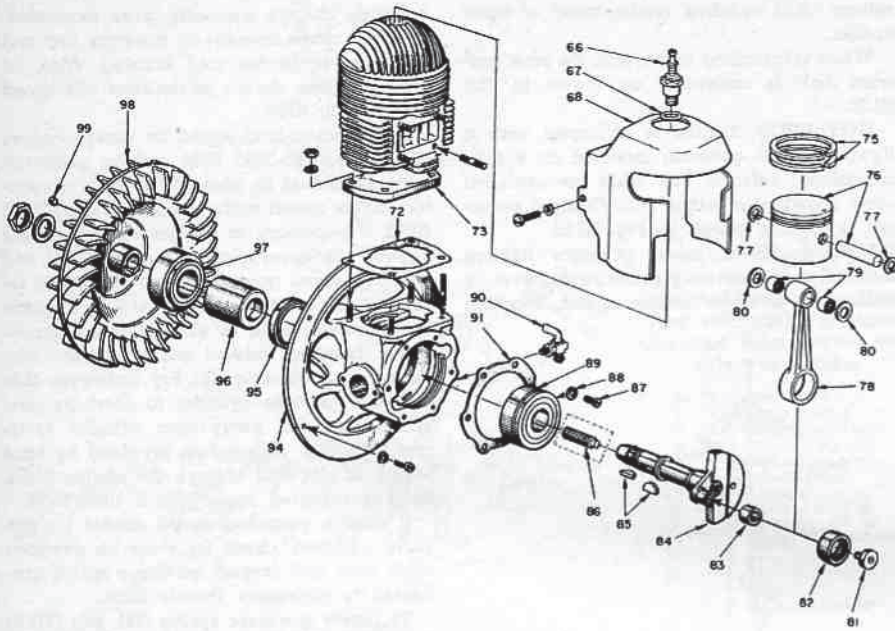

Fig. HL27—Exploded view showing model 251 engine crankcase, cylinder, rod and piston assembly, fan, crankshaft (output end) and related parts. Petcock (90) is to drain crankcase should it become flooded with fuel; do not attempt to start and run engine with petcock open.

- | | | | |
|------------------------|-----------------------------|----------------------------------|----------------------|
| 66. Spark plug | 78. Connecting rod | 85. Woodruff keys | 90. Petcock |
| 67. Spark plug gasket | 79. Needle bearings | 86. Stud bolts (25183 pump only) | 91. Crankcase gasket |
| 68. Cylinder shield | 80. Thrust washers | 87. Bearing retaining screws | 94. Crankcase |
| 72. Cylinder gasket | 81. Crankpin screw | 88. Bearing retaining washers | 95. Oil seal |
| 73. Cylinder | 82. Roller bearing | 89. Bearing | 96. Spacer |
| 75. Piston rings | 83. Inner race | | 97. Bearing |
| 78. Piston & pin assy. | 84. Crankshaft (output end) | | 98. Fan |
| 77. Snap rings | | | 99. Cork plug |

Model 51 and Merc-O-Tronic testers are given below:

Graham Model 51:

| | |
|-------------------|--------|
| Maximum secondary | 10,000 |
| Maximum primary | 1.7 |
| Coil index | .65 |
| Maximum coil test | .20 |
| Maximum gap index | .65 |

Merc-O-Tronic

| | |
|------------------------------|-----|
| Operating amperage | 1.3 |
| Minimum primary resistance | 0.6 |
| Maximum primary resistance | 0.7 |
| Minimum secondary continuity | .50 |
| Maximum secondary continuity | .60 |

If ignition coil does not meet test specifications, renew using correct part number coil. It is important that a substitute coil not be used with the solid state ignition system. If coil tested ok, check switch box as follows:

With leads and condenser disconnected as shown in Fig. HL26, connect one ohmmeter lead to one switch box test point (flag terminal or ground lead) and other ohmmeter lead to remaining switch box test point. The ohmmeter reading should be either between 5 to 25 ohms or from one megohm to infinity. When ohmmeter test leads are reversed, the opposite reading should be observed. If these ohmmeter readings are not observed, renew magneto cover and switch box assembly. If ignition coil and switch box both test ok, check trigger coil as follows:

Connect ohmmeter positive lead to junction of switch box and trigger coil leads and ohmmeter negative lead to magneto housing (see "Trigger Coil Test Points" in Fig. HL26). It is not necessary to disconnect trigger coil

lead from switch box lead. The ohmmeter reading should be 22 to 24 ohms.

To check condenser, stick a pin through the condenser lead to provide a contact point, then test condenser using standard procedure to check series resistance, short and capacitance. Condenser capacitance should be 0.16-0.20 mfd.

If either the switch box or condenser tested faulty, renew the complete condenser, switch box and magneto cover assembly.

LUBRICATION. Engine is lubricated by oil mixed with fuel. Homelite 2-cycle motor oil is recommended; however, SAE-30 non-detergent motor oil may be used if Homelite oil is not available. Do not use multi-grade motor oils. Mix 1/2-pint of oil with each gallon of gasoline. Always mix oil and gasoline thoroughly in separate container, then pour mixture into fuel tank.

AIR AND FUEL FILTERS. The air cleaner element may be washed in a detergent and water solution or by sloshing it around in a container of non-oily solvent. After a number of cleanings, the filter pores may become permanently clogged, making it necessary to renew element.

The fuel filter is a part of the fuel pick-up inside fuel tank and can be fished out filler opening using a wire hook. Under normal operations, the filter element should be changed at intervals of from one to two months. If engine is run continuously or fuel is dirty, filter may need to be changed weekly or more often if necessary.

CARBON. The carbon should be cleaned from exhaust ports at 100 to 200 hour intervals. Remove muffler, crank piston to top dead center and use a wooden or plastic

scraper to remove carbon deposits. Avoid scratching piston or damaging edges of port.

REPAIRS

COMPRESSION PRESSURE. Engine should have a minimum compression of 135 psi when tested while still warm from operation. A 14 mm. screw-in type tester should be used.

CONNECTING ROD. Connecting rod lower end is fitted with a roller bearing (82—Fig. HL27) which rides on a renewable inner race (83). To remove piston and connecting rod assembly from crankshaft (84) crankpin, first remove cylinder and the magneto housing and crankshaft rotor end assembly. Place a block of wood between crankshaft throw and crankcase to keep crankshaft from turning, then unscrew crankpin screw (81) (counterclockwise) with 3/8-inch Allen wrench. If renewal of inner race is indicated, remove race from crankpin. Usually, race will slide off of pin; however, it may be necessary to pry race from crankpin with screwdrivers.

To renew crankpin needle roller bearing in the connecting rod, press old bearing out using plug (Homelite tool No. 24120-1), supporting rod on sleeve (Homelite tool No. 24118-1). Install new bearing by supporting rod on sleeve (Homelite tool No. 24124-1) and pressing bearing in with same plug as used to remove old bearing. Shouldered face of sleeve (24124-1) will properly position bearing so that it protrudes equally from each side of rod.

To renew piston pin bearings, support rod on sleeve (Homelite tool No. 24124-1) and press bearings out with plug (24131-1). New bearings are installed separately from opposite ends of bore. Support rod on sleeve (24124-1) and using straight end of plug (24131-1) (end with recessed face), press new bearing in (press on lettered side of cage only) until shoulder of plug seats against rod. Turn rod over and press other new bearing into rod in same manner. When properly installed, recessed faces of piston pin thrust washers will clear protruding bearing races and will contact connecting rod.

When reinstalling connecting rod and bearing inner race, thoroughly lubricate all parts and tighten connecting rod cap screw to a torque of 50 Ft.-Lbs. Note: Locate connecting rod on crankpin so that oil hole in upper end of rod will be towards intake side of engine. Piston should be assembled to connecting rod so that piston ring locating pin will be to same (intake) side of assembly as oil hole in rod.

PISTON, PIN AND RINGS. Piston is accessible after removing cylinder from crankcase. Always support piston while removing or installing piston pin. Piston should be renewed if ring side clearance, measured with new ring installed in top groove, exceeds 0.004. Also, renew piston if piston skirt to cylinder bore clearance exceeds 0.007 when measured with new or unworn cylinder. Inspect piston ring locating pin and renew piston if pin has worn to half of its original thickness. Piston pin should be a snug push fit to light press fit in piston. Piston, pin and rings are available in standard size only. Homelite recommends

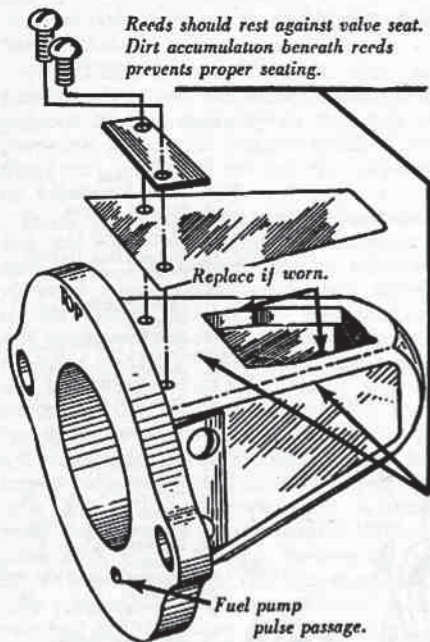

Fig. HL29—View showing reed valve assembly with one valve reed removed. Inspect seat and reeds as noted and be sure fuel pump pulse passage is open.

that piston rings be renewed whenever engine is disassembled for service.

When reassembling piston to connecting rod, insert new snap ring in exhaust side (opposite ring locating pin) side of piston. Lubricate all parts and place piston, exhaust side down, in holding fixture. (Note: A used cylinder sawed in half makes a good holding fixture.) Press pin into upper (intake) side of piston, then insert connecting rod and thrust washers into piston with oil hole in rod up and recessed sides of washers next to piston pin bearings in rod. Press pin on through the assembly and secure with new snap ring. Be sure that piston and rod assembly is installed on crankpin with pinned (intake) side of piston away from exhaust port side of engine.

CYLINDER. Cylinder bore is chrome plated. This plating is light gray in color and does not have the appearance of ordinary polished chrome. Because coating is honed after plating, it looks much like the aluminum cylinder base metal. If plating has been penetrated by scoring or wear, the aluminum underneath will appear as a bright area. These bright areas are usually, but not always located at the edges of exhaust ports. If further checking, as mentioned below, shows that chrome has been penetrated, renew cylinder.

In some instances, particles of metal are torn loose from piston and deposited on top of cylinder plating. This condition is usually indicated by a rough, flaky appearance of the bore and can be removed by using a rubber impregnated grinding wheel on a 1/4-inch electric drill. If a screwdriver can be run over cleaned surface without leaving marks thereon, chrome is intact and the cylinder is suitable for further service. If screwdriver scratches surface, renew cylinder.

Fig. HL30 — Exploded view of rewind starter used on model 251 engine. Starter cup (1) has notches for using emergency starting rope.

1. Starter cup
2. Lock washer
3. Crankshaft nut
4. Snap ring
5. Retaining washer
6. Brake spring
7. Brake washer
8. Friction shoe assembly
9. Starter pulley
10. Starter rope
11. Handle insert
12. Handle
13. Rewind spring
14. Starter cover

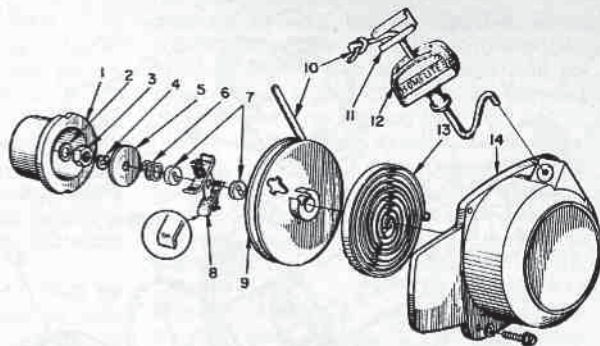

CRANKSHAFT, BEARINGS AND SEALS. The two-piece crankshaft can be serviced as two separate parts. Refer to following appropriate paragraph for information under "CRANKSHAFT, MAGNETO END" or "CRANKSHAFT, OUTPUT END."

CRANKSHAFT, MAGNETO END. To service the shaft, bearings, seal or governor components, proceed as follows: Remove rewind starter as an assembly. Unscrew magneto rotor retaining nut and using suitable puller (Homelite tool No. AA-22560 or equivalent), remove rotor. Disconnect governor linkage and remove governor bellcrank. Using a 1/8-inch Allen wrench, remove the six socket head screws retaining magneto housing to crankcase and remove housing and shaft assembly. Remove the two screws retaining bearing housing (20—Fig. HL24) to magneto housing (45) and separate shaft and bearing assembly from housing (45). Bearing (47) can be renewed at this time. Remove snap ring (34), retainer (33) and governor spring (32)

and pry governor back plate (25), with weights, from shaft (17). Remove spacer (24), support bearing housing (20) and press shaft from housing. Remove crankshaft seal (21) and snap ring (23), then press bearing (22) from housing.

To assemble magneto end shaft and bearing assembly, proceed as follows: Install new seal (21) in housing with lip of seal towards crankcase side. Lubricate seal and insert shaft through seal and housing. Support flat inner end of shaft and press bearing (22) down over shaft and into housing until bearing inner race is seated against shoulder on shaft. Then, support housing and press bearing outer race into housing so that retaining snap ring (23) can be installed. Place spacer (24) on shaft, then drive or press governor back plate onto shaft against spacer. Install governor cup, spring, spring retainer and snap ring. Attach bearing housing to magneto housing with the two screws, then reinstall shaft, bearing housing

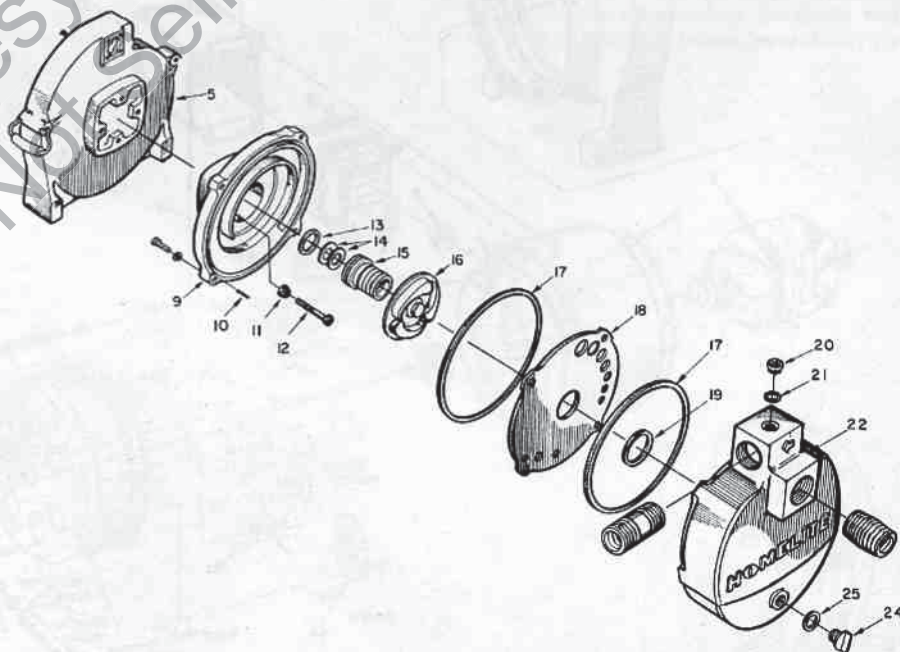
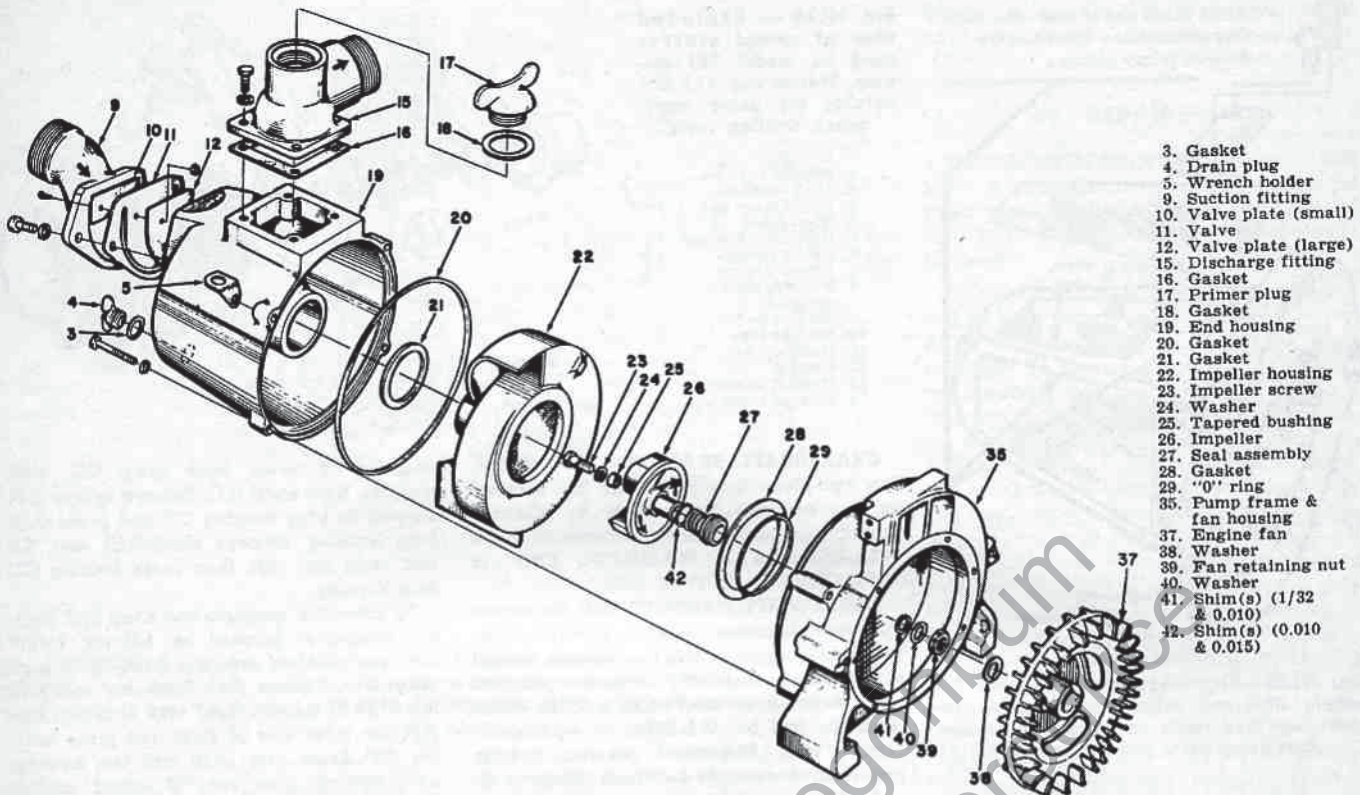

Fig. HL31—Exploded view of model 251S3 pump assembly. Impeller (16) threads onto stud (86—Fig. HL27) threaded into output end of crankshaft. Use shims (14) as required to maintain 0.020-0.030 clearance between impeller and wear plate (18).

- | | | | |
|-----------------------|---------------------------------|-------------------|-----------------|
| 5. Engine fan housing | 12. Cap screws (to fan housing) | 15. Seal assembly | 20. Primer plug |
| 9. Impeller housing | 13. Washer | 16. Impeller | 21. Gasket |
| 10. Spirol pin | 14. Shims (1/32 & 0.010) | 17. Gaskets | 22. End housing |
| 11. Sealing washer | | 18. Wear plate | 24. Drain plug |
| | | 19. Gasket | 25. Gasket |



- 3. Gasket
- 4. Drain plug
- 5. Wrench holder
- 9. Suction fitting
- 10. Valve plate (small)
- 11. Valve
- 12. Valve plate (large)
- 15. Discharge fitting
- 16. Gasket
- 17. Primer plug
- 18. Gasket
- 19. End housing
- 20. Gasket
- 21. Gasket
- 22. Impeller housing
- 23. Impeller screw
- 24. Washer
- 25. Tapered bushing
- 26. Impeller
- 27. Seal assembly
- 28. Gasket
- 29. "O" ring
- 35. Pump frame & fan housing
- 37. Engine fan
- 38. Washer
- 39. Fan retaining nut
- 40. Washer
- 41. Shim(s) (1/32 & 0.010)
- 42. Shim(s) (0.010 & 0.015)

Fig. HL32—Exploded view of model 251TP3 pump assembly. Impeller screw (23) threads into end of engine crankshaft. Impeller is not solidly connected to engine crankshaft and can slip on tapered bushing (25) and end of crankshaft should a solid object become lodged between impeller and housing.

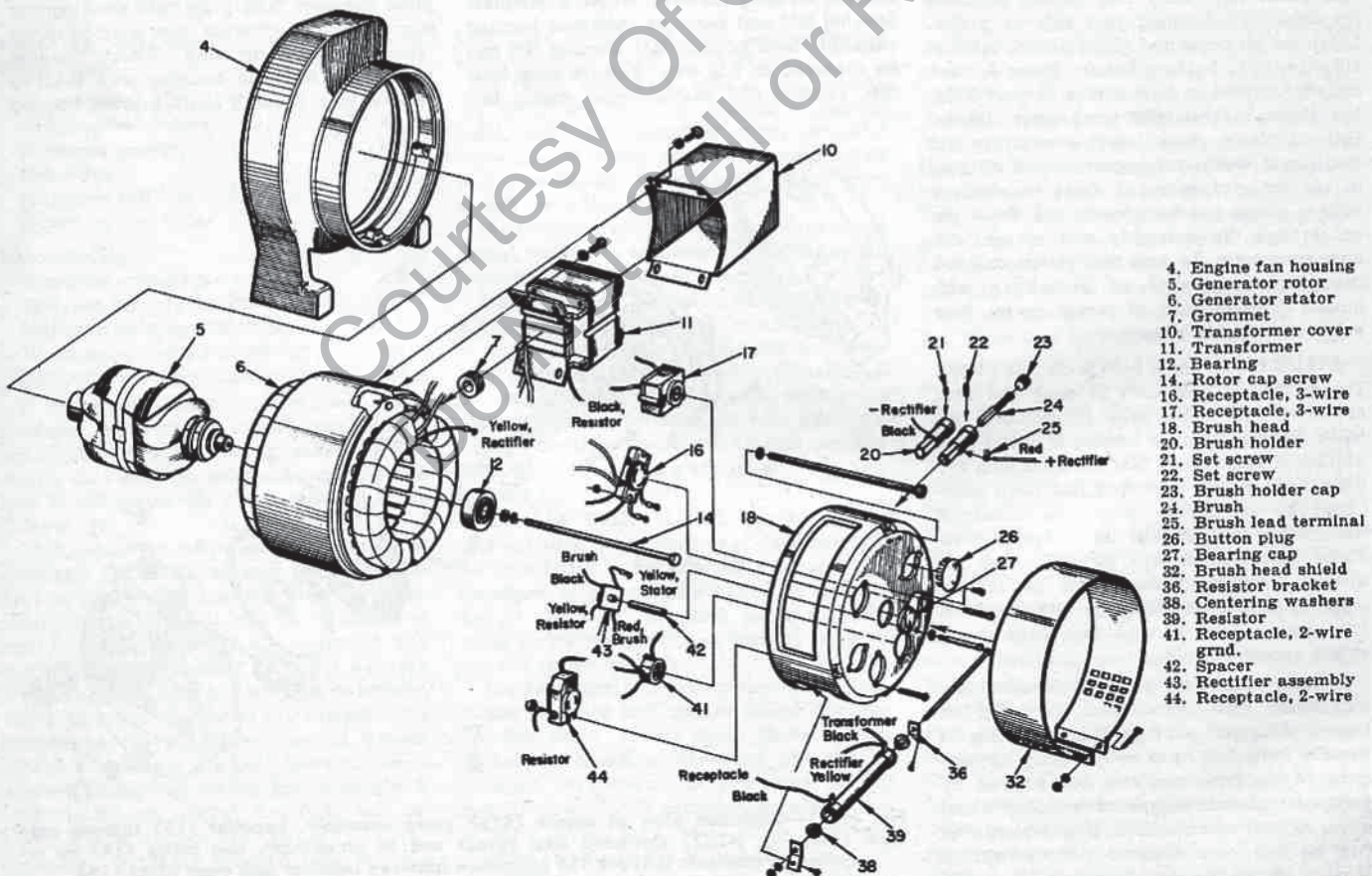

- 4. Engine fan housing
- 5. Generator rotor
- 6. Generator stator
- 7. Grommet
- 10. Transformer cover
- 11. Transformer
- 12. Bearing
- 14. Rotor cap screw
- 16. Receptacle, 3-wire
- 17. Receptacle, 3-wire
- 18. Brush head
- 20. Brush holder
- 21. Set screw
- 22. Set screw
- 23. Brush holder cap
- 24. Brush
- 25. Brush lead terminal
- 26. Button plug
- 27. Bearing cap
- 32. Brush head shield
- 36. Resistor bracket
- 38. Centering washers
- 39. Resistor
- 41. Receptacle, 2-wire grnd.
- 42. Spacer
- 43. Rectifier assembly
- 44. Receptacle, 2-wire

Fig. HL33—Exploded view of model 251A35 generator assembly. Rotor (5) is retained on tapered end of engine crankshaft by cap screw (14); to remove rotor, remove cap screw, insert armature pin (Homelite part No. 22271) cut to length of 7 3/4 inches) and thread special jack screw (part No. S-394). Tap the tightened jack screw with hammer to break armature loose from crankshaft.

and magneto housing to crankcase using new gasket.

CRANKSHAFT, OUTPUT END. First, remove magneto end crankshaft, bearing and magneto housing assembly as described in preceding paragraph. Remove cylinder and piston and connecting rod unit, then proceed as follows:

Remove the crankcase, output crankshaft end and blower rotor (fan) as an assembly from pump or generator; refer to exploded views of pump and generator units shown in this section. Remove fan retaining nut and washer and the two crankshaft bearing retaining screws (87—Fig. HL27) and washers (88). Support magneto (open) end of crankcase, then press crankshaft (84) from fan and crankcase. Remove the three corks (99) from fan, insert jackscrews into the tapped holes and push bearing (97) from fan inner hub. Remove screws and reinstall corks. Support outer race of bearing (89) and press shaft out of bearing. Remove spacer (96) and crankshaft seal (95) from crankcase.

To reassemble, proceed as follows: Press new seal into crankcase with lip towards inside (away from fan). Support outer hub of fan, then press new bearing (97) onto fan inner hub. Press new inner bearing (89) into crankcase with retaining groove in outer race properly positioned. Support bearing inner race with sleeve, then press crankshaft into bearing. Install bearing retaining screws and washers. Place spacer (96) in position on crankshaft, then carefully press fan onto shaft making sure that keys and keyways are aligned. Install fan retaining washer and nut securely. Complete reassembly by installing connecting rod and piston, cylinder and magneto end assembly.

CRANKCASE. To renew crankcase, follow procedures as outlined in previous para-

graph "CRANKSHAFT, OUTPUT END".

REED INTAKE VALVE. Engine is equipped with a pyramid reed valve assembly shown in Fig. HL21. The reed valve should be inspected whenever carburetor is removed. Refer to Fig. HL29 for inspection points. When installing new reeds on pyramid seat, thoroughly clean all threads and apply Loctite to threads on screws before installing. Be sure reeds are centered before tightening screws.

REWIND STARTER. Refer to Fig. HL30 for exploded view. In an emergency in case of rewind starter failure, engine can be started by removing starter and winding a rope around starter cup (1).

CENTRIFUGAL PUMP. To remove pump from engine, remove end housing (22—Fig. HL31) taking care not to damage gaskets. Unscrew impeller clockwise by placing wrench on hex portion and striking wrench a sharp blow with hammer. Note: The impeller is mounted on a stud bolt threaded into end of engine crankshaft; the impeller may unscrew off of the stud or stud may be removed with impeller. Take care not to lose the shims (14) or washer (13). After removing impeller, impeller housing can be unbolted and removed from engine fan housing (5).

Before assembling pump, lubricate seal seat and seal head with oil and make sure gaskets are in good condition. Shims (14) are used as required to maintain minimum clearance between impeller and wear plate (18). When reassembling, place wear plate against impeller housing without a gasket and turn engine by hand to be sure impeller does not rub against wear plate.

TRASH PUMP. Refer to Fig. HL32. To remove pump, first remove end housing (19) from pump body and fan housing (35). Remove impeller housing (22) if not removed

with end housing. Unscrew impeller retaining cap screw (23) and remove washer (24), tapered bushing (25), impeller and seal assembly. The engine can then be unbolted and removed from housing (35).

Before reassembling pump, make sure gaskets and shaft seal are in good condition, lubricate seal seat and seal head, then proceed as follows: A 0.010 to 0.020 clearance between impeller and impeller housing is maintained by varying number of shims (41) between impeller hub and washer (40). Add shims until impeller just contacts impeller housing when housing is held in position, then remove one 0.015 thick shim. Compressed length of seal assembly (not including seat) should be $\frac{7}{8}$ -inch, plus or minus 0.010, and is adjusted by adding or removing shims (42) between seal head and impeller. Seal length should be measured after impeller to impeller housing clearance is adjusted. After impeller clearance and seal length are correct, complete reassembly of pump.

GENERATORS. Exploded view of model 251 A35 generator is shown in Fig. HL33 and model 251 HY 35-1 exploded view is shown in Fig. HL34. Care should be taken in disassembly of the generator that any leads disconnected should be identified so that they be reconnected properly. Also, if brushes are to be reinstalled, they should be identified so they can be installed in same location and position from which they were removed. Carefully disassemble to avoid damage to wiring or insulation.

Generator rotor (5—Fig. HL33 or 27—Fig. HL34) can be removed from engine crankshaft by inserting a pin (Homelite No. 22271 cut to a length of $7\frac{3}{4}$ inches measured from tapered end) into rotor after removing retaining cap screw (14—Fig. HL33 or 9—Fig. HL34). Then, thread a jackscrew (Homelite No. S-394) into rotor, tighten jackscrew and tap with hammer to loosen taper fit.

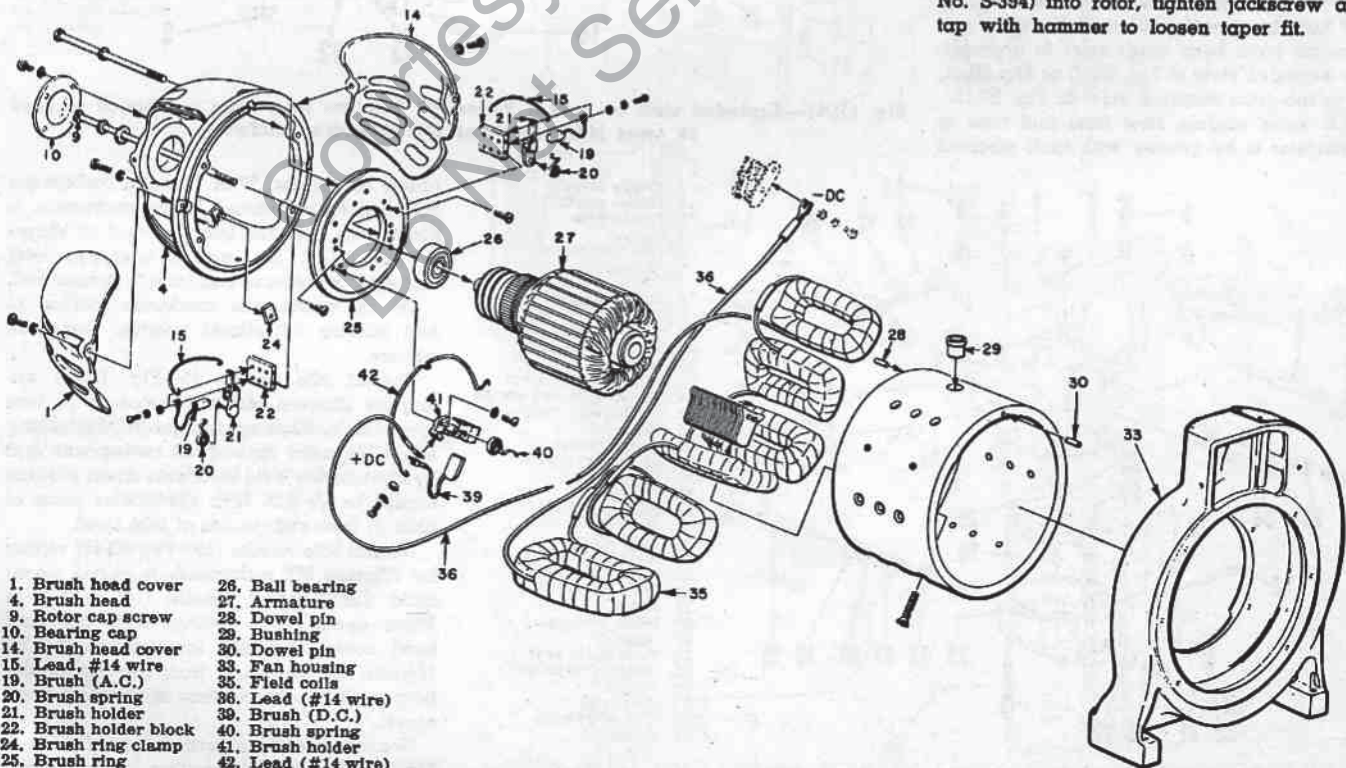

- | | |
|------------------------|---------------------|
| 1. Brush head cover | 26. Ball bearing |
| 4. Brush head | 27. Armature |
| 9. Rotor cap screw | 28. Dowel pin |
| 10. Bearing cap | 29. Bushing |
| 14. Brush head cover | 30. Dowel pin |
| 15. Lead, #14 wire | 33. Fan housing |
| 19. Brush (A.C.) | 35. Field coils |
| 20. Brush spring | 36. Lead (#14 wire) |
| 21. Brush holder | 39. Brush (D.C.) |
| 22. Brush holder block | 40. Brush spring |
| 24. Brush ring clamp | 41. Brush holder |
| 25. Brush ring | 42. Lead (#14 wire) |

Fig. HL34—Exploded view of model 251HY35-1 generator assembly. Cap screw (9) retains generator rotor (27) to engine crankshaft.

HOMELITE

A **Textron** DIVISION
 PORT CHESTER, N.Y. U.S.A.

| ENGINE MODEL | Bore | Stroke | Displacement |
|--------------|-------|--------|--------------|
| 8 | 2 3/4 | 2 1/8 | 12.62 |
| 9, 9-A | 2 3/4 | 2 1/8 | 12.62 |
| 20 | 2 3/4 | 1 1/2 | 6.63 |
| 23 | 2 1/4 | 2 1/8 | 8.45 |
| 24 | 2 3/8 | 2 1/8 | 11.50 |
| 35 | 2 1/8 | 1 1/2 | 7.0 |
| 36 | 2 1/4 | 2 1/8 | 8.45 |

This section covers Homelite 2-cycle engines used on various pumps and generators. The unit model number (such as pump model number S8 3-1 or generator model 9A115-1) also indicates engine model number (which would be model 8 and model 9 respectively). The pump or generator must be at least partially disassembled to perform certain engine service operations.

CAUTION: Centrifugal type pumps should not be operated without water in pump. Water is necessary for lubrication of the pump seal while engine is running. Cap suction side of pump and fill pump with water before starting engine when pump is assembled.

MAINTENANCE

SPARK PLUG. Recommended spark plug for all except 36S2 and 8S3-1 pumps is Champion HO-8A or UJ-11-G. Models 36S2 and 8S3-1 require a Champion UJ-22 spark plug. Model J6 or J6J Champion plugs can be substituted for HO-8A or UJ-11-G; but will be more susceptible to fouling and electrode erosion. Electrode gap for all models should be 0.025.

CARBURETORS. Tillotson Series MD and MT float type carburetors and Homelite carburetors have been used; refer to appropriate exploded view in Fig. HL40 or Fig. HL41, or to the cross-sectional view in Fig. HL43.

On some models, flow from fuel tank to carburetor is by gravity with tank mounted

1. Pipe plug
2. Float bowl cover
3. Float pin
4. By-pass tube
5. Main nozzle
6. Gasket
7. Choke shaft
8. Choke disc
9. Expansion plug
10. Choke friction pin
11. Spring
12. Gasket
13. Packing nut
14. Main fuel needle
16. Expansion plug
17. Carburetor body
18. Throttle disc
19. Gasket
20. Float
21. Inlet valve Assy.
22. Gasket
23. Idle fuel needle
24. Spring
25. Spring
26. Idle stop screw
27. Throttle shaft
28. Throttle stop lever
29. Throttle lever

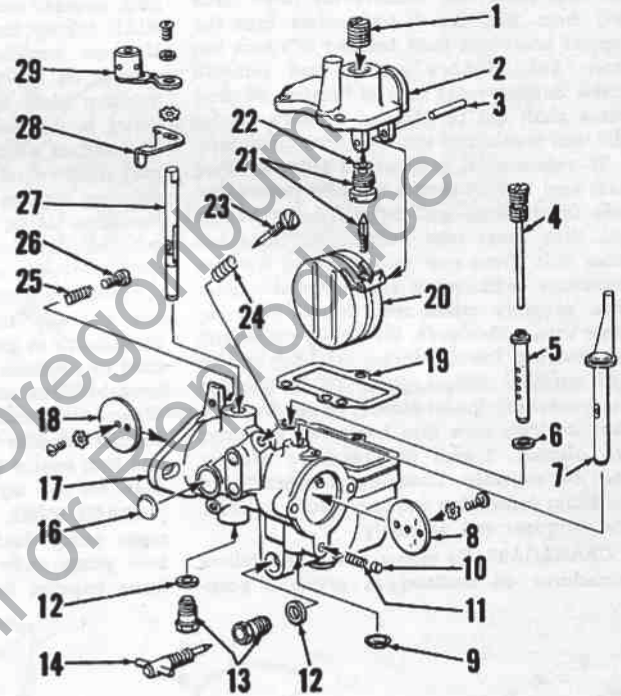

Fig. HL41—Exploded view of typical Series MT Tillotson float type carburetor as used on some Homelite pump and generator models.

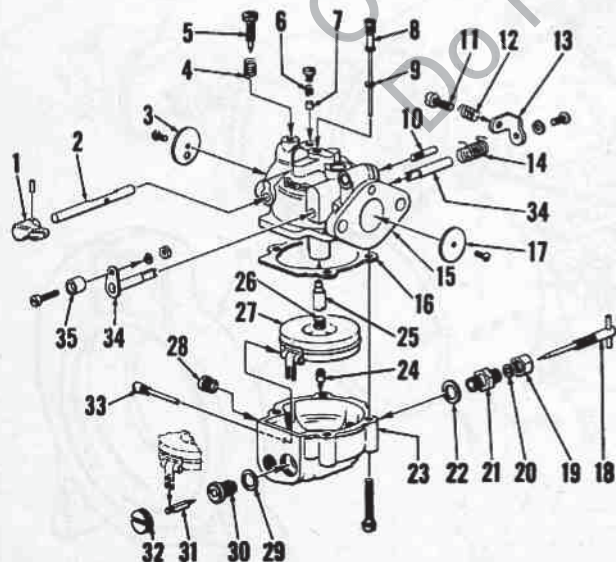

Fig. HL40—Exploded view of typical Tillotson Series MD carburetor as used on some Homelite pump models.

above carburetor. With Tillotson carburetors and fuel tank mounted below carburetor, a diaphragm type fuel pump is used as shown in Fig. HL42. On models equipped with Homelite carburetor, fuel tank is pressurized. On all carburetors, clockwise rotation of fuel mixture adjustment needles leans the mixture.

Normal idle needle (5—Fig. HL40) setting for Tillotson MD carburetors is 1/4 turn open; main (high speed) needle (18) setting is 1 1/4-1 1/2 turns open. Float setting with fuel bowl assembly held in upside down position should be 3/8-inch from the lowest point of float at free end, to rim of fuel bowl.

Normal idle needles (23—Fig. HL41) setting for Tillotson MT carburetors is 3/4-turn open; main (high speed) needle (14) setting is 1-turn open. Float setting, with the float bowl cover assembly inverted, should be 1 1/2-inch as measured from the top of the float to the gasket surface of the float bowl cover.

Normal mixture adjustment needle (32—Figs. HL43 and HL44) setting for the Homelite carburetor is 1 1/2 turns open. Carburetor

Fig. HL42—Exploded view of fuel system on models using Tillotson float type carburetor. Exploded view of carburetor is shown in Fig. HL41. Actuating primer bulb (14) will pump fuel into carburetor float bowl.

- | | |
|----------------------|-----------------------|
| 1. Fuel tank | 11. Carburetor assy. |
| 2. Fuel filter | 12. Fuel line |
| 3. Pump suction line | 13. Ring |
| 4. Pump pulse line | 14. Priming bulb |
| 5. Pump body | 15. Adapter |
| 6. Pump diaphragm | 16. Filler cap |
| 7. Gasket | 17. Gasket |
| 8. Diaphragm cover | 18. Air cleaner cover |
| 9. Pipe plug | 19. Element |
| 10. Gasket | 20. Adapter |

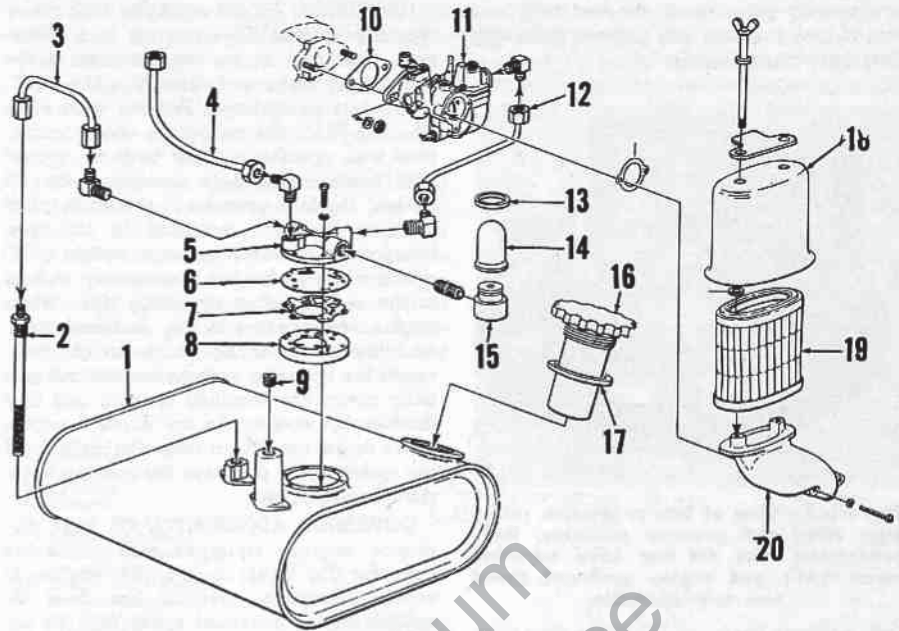

Fig. HL43—Exploded view of fuel system on models equipped with Homelite carburetor. Refer to Fig. HL44 for cross-sectional views of carburetor assembly. Fuel tank is pressurized to force fuel upward into carburetor.

- | | |
|--------------------|----------------------|
| 8. Hose clamps | 26. Gasket |
| 9. Adapter hose | 27. Sleeve |
| 10. Fuel cap | 28. Jet |
| 11. Gasket | 29. Carburetor body |
| 12. Fuel tank | 32. Fuel needle |
| 13. Filter plug | 34. Gasket |
| 14. Filter adapter | 35. Spring |
| 15. Screen | 36. Priming valve |
| 16. Washer | 37. Gasket |
| 17. Screw | 38. Carburetor cover |
| 18. Gasket | 39. Adapter |
| 19. Drain plug | 40. Vent tube |
| 23. Plunger tube | 41. Filter element |
| 24. Primer plunger | 42. Air filter cover |
| 25. Gasket | 44. Washer |

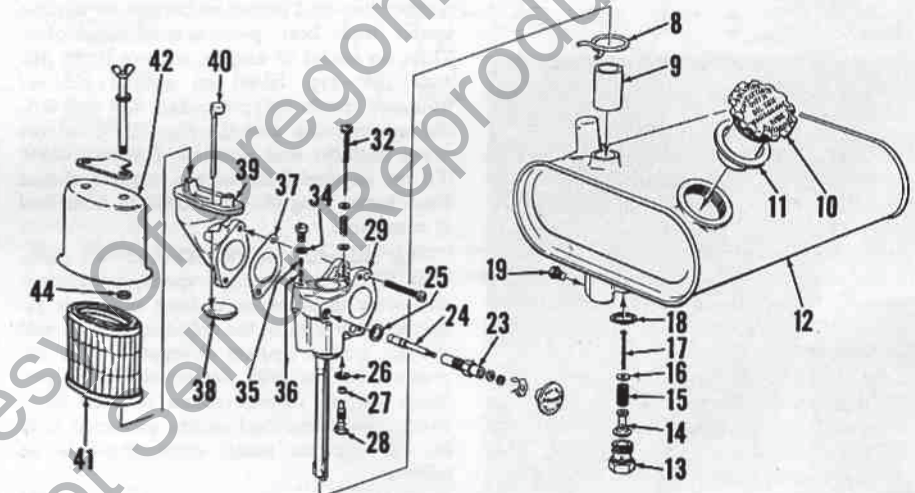
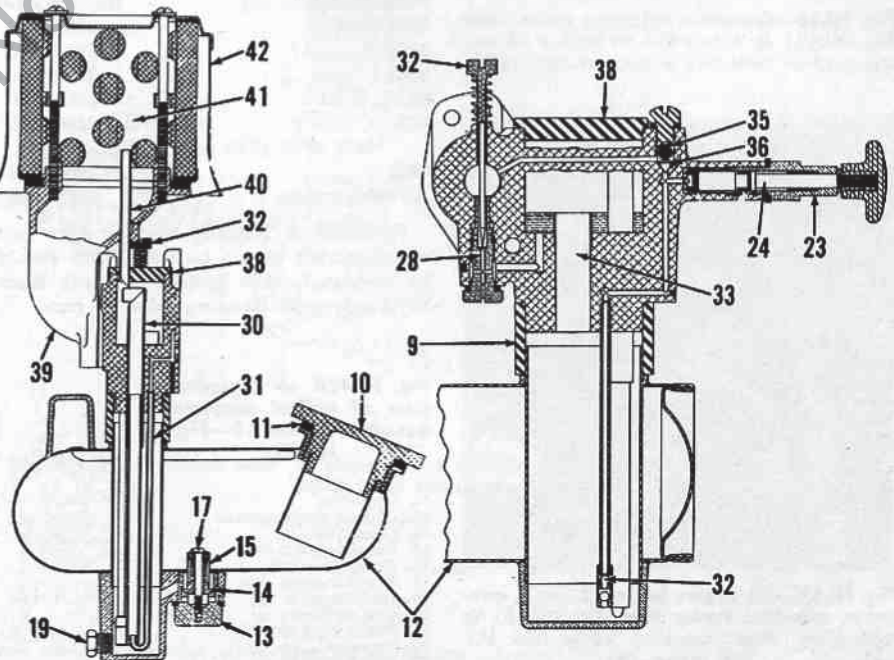

Fig. HL44—Cross-sectional view of Homelite carburetor. Refer to Fig. HL43 for additional legend and exploded view of complete fuel system.

- | |
|--------------------------------|
| 3. Priming tube and foot valve |
| 30. Feed tube |
| 31. Pressure tube |
| 33. Overflow tube |



operates by pressurizing the fuel tank and loss of tank pressure will prevent carburetor from operating properly.

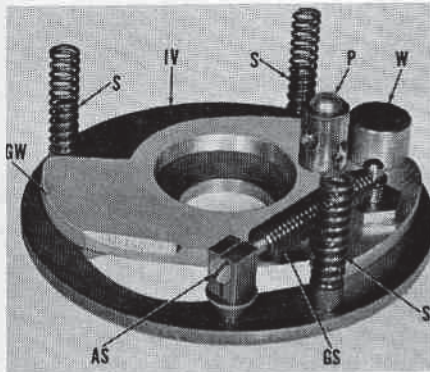

Fig. HL45—View of late production rotary inlet valve and governor assembly. Early production units did not have adjusting screw (AS) and engine governed speed was non-adjustable.

- AS. Adjusting screw
- GS. Governor spring
- GW. Governor weight & plate assy.
- IV. Intake valve plate
- P. Pivot post
- S. Springs
- W. Weight

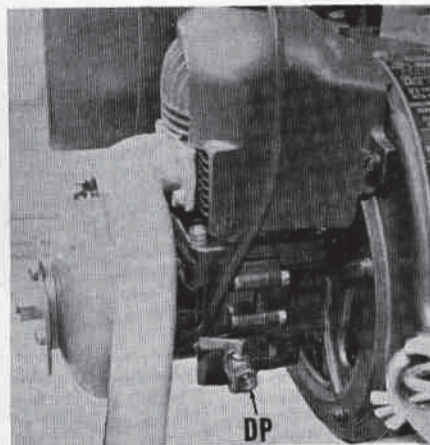

Fig. HL46—Governor adjusting screw (see Fig. HL45) is accessible on model 35 engines after removing drain petcock (DP).

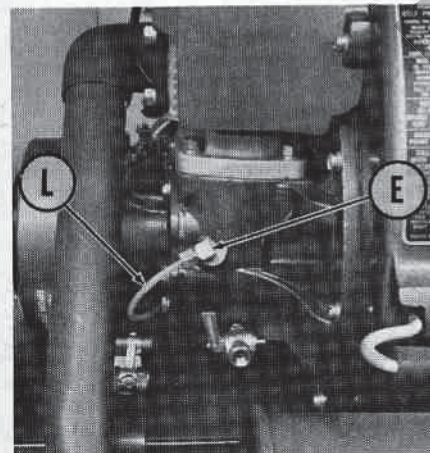

Fig. HL47—On engine models 8 and 9, governor adjusting screw (see Fig. HL45) is accessible after removing pulse line (L) and elbow (E).

GOVERNOR. All are equipped with rotary type inlet valves. The governor is a centrifugal type and is an integral part of the rotary inlet valve as indicated in Fig. HL45. On models so equipped, Formica wear plate (15—Fig. HL50) is pinned to the engine crankcase with opening in wear plate in register with intake opening in crankcase. On all models, the inlet opening in the valve plate (IV—Fig. HL45) is controlled by the combination shutter and governor weight (GW) which when the engine is stationary, is held in the open position by spring (GS). When engine speed exceeds the designed limit, centrifugal force acting on the weight overcomes the opposing spring pressure and partially covers the manifold opening and thus throttles the engine. As the throttled engine slows down, centrifugal force diminishes and the spring again uncovers the opening to restore engine speed.

GOVERNOR ADJUSTMENT. On later production engines equipped with adjustable governor (Fig. HL45) or on earlier engines in which adjustable governor has been installed, engine governed speed may be adjusted as follows:

First, bring engine to normal operating temperature and adjust carburetor for highest speed and best performance obtainable. Then, on model 35 engine, remove drain petcock (DP—Fig. HL46) on muffler side of front-half crankcase; on models 8, 9 and 9-A, disconnect pulse line (L—Fig. HL47) (above drain petcock) and unscrew the 90° elbow (E); or, on model 20 engine, remove slotted head brass plug (P—Fig. HL48) in front half of crankcase.

Turn adjusting screw (AS—Fig. 45) clockwise to increase no-load speed, or counterclockwise to decrease no-load speed as required. One turn of the adjusting screw will change engine no-load governed speed approximately 100 RPM. Accurately adjust generator engine no-load speed to 3750 RPM. Recommended no-load engine governed RPM for the various pump applications is as follows:

| Pump Model | No-Load RPM |
|-----------------------------------|-------------|
| 20S1½-1A | 3900-4000 |
| 20DP-3 | 2850-2950 |
| 35S2-1 | 2850-2950 |
| 8S3-1, 9S3-1 | 2850-2950 |
| 8S3-1P, 9S3-1P | 4200-4300* |
| *3850 RPM at 60 psi pump pressure | |
| 36S2 | 2650-2750 |
| All other pumps | 3800-3900 |

IGNITION & TIMING. Breaker point gap on all models should be 0.020. Gap should be measured when breaker arm rub block is 1/8-inch past breaking edge of cam.

Fig. HL49A — Exploded view of typical magneto assembly (see 10—Fig. HL49).

- 11. Back plate
- 12. Grommet
- 13. Ground (switch) lead
- 14. Condenser
- 15. Breaker point base
- 16. Cam wiper felt
- 17. Breaker point arm
- 18. Ignition coil
- 19. Coil wedges
- 20. Spark plug wire
- 21. Terminal
- 22. Spark plug boot

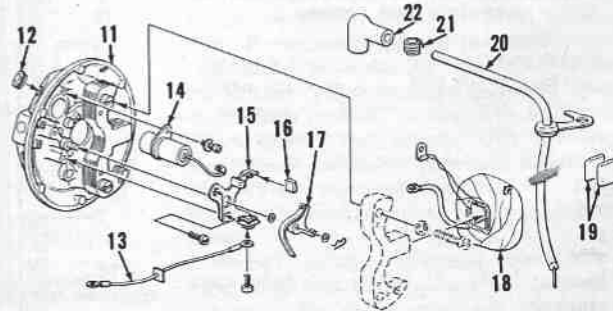

Breaker spring tension should be 14-21 oz. as measured at center of breaker shoe. Ignition timing is fixed and non-adjustable. The cam must be installed with arrow facing out. Refer to Figs. HL49 and HL49A for typical magneto assembly.

- Condenser capacity0.34 mfd
- Coil primary0.95 ohms
- Coil secondary5500-6000 ohms

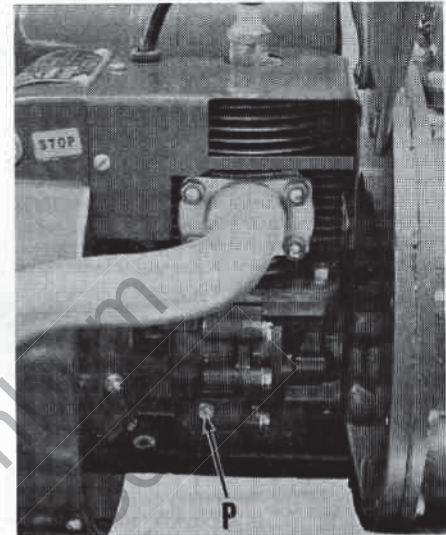

Fig. HL48—On engine model 20, governor adjusting screw (see Fig. HL45) is accessible after removing slotted head plug (P).

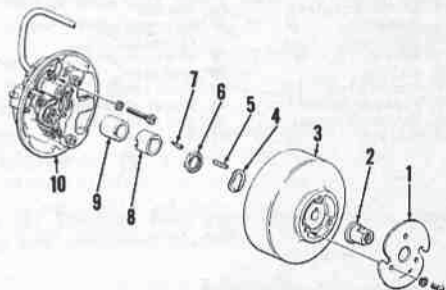

Fig. HL49—To remove magneto rotor (3), unscrew retaining nut (2) against plate (1) which acts as puller. Some models do not have magneto cam retaining nut (6). Notch in inner end of cam (8) must fit over pin in spacer (9).

- 1. Starter plate
- 2. Rotor nut
- 3. Magneto rotor (flywheel)
- 4. Wave washer
- 5. Rotor key
- 6. Breaker cam nut
- 7. Breaker cam key
- 8. Breaker cam
- 9. Cam spacer
- 10. Magneto assembly

FUEL AND LUBRICATION. On models 20 and 36, ¼ pint of good quality SAE 30 motor oil should be mixed with each gallon of gas.

On models 8, 9, 9-A and 23, ½ pint of good quality SAE 30 motor oil should be mixed with each gallon of gas.

On Model 24, nameplate specifies ¾ pint of good quality SAE 30 non-detergent oil should be mixed with each gallon of gas; however, a mixture of ½ pint SAE 30 motor oil to each gallon of regular gasoline can be safely used in these models.

REPAIRS

CLEANING CARBON. Carbon deposits should be cleaned from the exhaust ports and muffler at regular intervals. When scraping carbon be careful not to damage the finely chamfered edges of the exhaust ports.

CONNECTING ROD. On model 20 engines, the connecting rod lower bearing is of the needle roller type and rod cap is detachable from rod. The rod and piston assembly can be removed from the engine after removing the cylinder assembly. Be careful to avoid loss of the 31 individual needle rollers in the crankcase. Crankpin diameter is 0.6937-0.6940. Renew connecting rod if surfaces of rod and cap which form the outer race for the needle rollers are rough, scored or worn. If any one needle roller is worn or if rollers can be separated more than the width of one needle, reject the bearing. This applies also to the needle roller caged bearing assembly or assemblies mounted in the upper end of the connecting rod. Homelite recommends the renewal of the crankpin (lower) connecting rod bearing at each overhaul.

Inspect crankpin and if it is scored or is out-of-round or tapered more than 0.001, install a new crankshaft.

Refer to PISTONS for correct reassembly of rod to piston. When reassembling rod to crankshaft always renew the Allen type retaining cap screws and align mating marks on rod and cap.

On models 36S2, 23S2, some 8S3-1, 8S3-1P and 8S3-1R and all 9S3-1, 9S3-1P and 9S3-1R (Refer to 42—Fig. HL52), the connecting rod lower bearing is of the double track ball bearing type. To remove the connecting rod, it is necessary to remove the cylinder, timer bracket and the connecting rod retaining Allen head screw (43); then, with the use of special pullers, remove the connecting rod and bearings. Renew bearing if it feels lumpy when rotated or has perceptible wear.

On models 24S3, 24S3-1P and some 8S3-1, 8S3-1P and 8S3-1R, the lower end of the connecting rod is equipped with 25 needle rollers (52—Fig. HL52). As the lower end of the rod doesn't have a removable rod cap, removal of the cylinder, timer bracket and Allen head connecting rod bearing retainer is necessary before removing the connecting rod and piston assembly. Install large washer (54) with tapered side of hole toward pump and small washer (51) with tapered side toward inlet valve. Race (53) should be heated to 180° F. to aid in assembling to crankpin.

PISTON RINGS, PISTONS AND PINS. On all models, the piston assembly is accessible after removing the cylinder assembly from crankcase. Always support the piston when removing or installing the piston pin. All models are equipped with an aluminum alloy piston.

Piston ring end gap should be 0.105 to 0.115 on piston with ring locating pin and 0.008 to 0.020 on models with unpinned rings. Side clearance of piston ring in groove should be 0.0025-0.004. Clearance between piston skirt and cylinder bore, measured at right angle to piston pin, should be 0.002-0.005 on models with 2¼ inch bore and 0.004-0.007 on other models.

On all models, reject the pin and the piston if there is any visible up and down play of pin in the piston bosses. Neither the piston or the pin are available separately.

Install new needle roller bearing assemblies to upper end of connecting rod if any of the rollers have slight flat spots or are pitted. Do likewise if rollers can be separated more than the thickness of one roller.

Inspect piston for cracks and for holes in dome of same and reject if any are found. Slight scoring of piston walls is permissible, but if rough surfaces are accompanied by a deposit of aluminum on cylinder walls, reject the piston. Refer to CYLINDER for methods of removing such deposits.

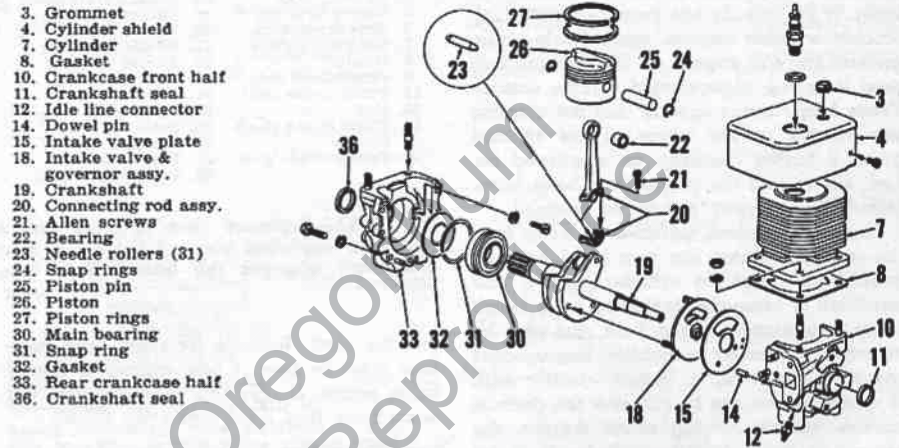

Fig. HL50—Exploded view of engine used on model 20DP3. Other model 20 engines are similar in construction.

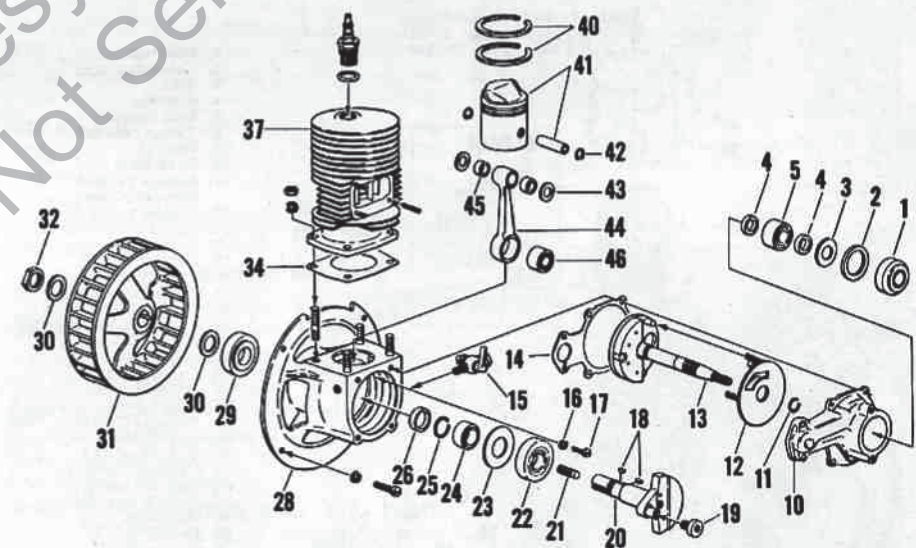

Fig. HL51—Exploded view of engine used on model 36S2 pump; engine used on 23S2 pump is of similar construction.

- | | | | |
|-----------------------------------|----------------------------------|------------------|----------------------|
| 1. Bearing | 13. Intake valve shaft | 22. Main bearing | 32. Fan nut |
| 2. Seal retaining ring | 15. Drain petcock | 23. Gasket | 34. Gasket |
| 3. Seal | 16. Lockwasher | 24. Spacer | 37. Cylinder |
| 4. Spacers | 17. Main bearing retaining screw | 25. Snap ring | 40. Piston rings |
| 5. Bearing | 18. Woodruff keys | 26. Spacer | 41. Piston & pin |
| 10. Timer bracket | 19. Crankpin screw | 28. Crankcase | 42. Snap rings |
| 11. Snap ring | 20. Crankshaft | 29. Fan bearing | 43. Washers |
| 12. Intake valve & governor assy. | 21. Pump drive stud | 30. Washer | 44. Connecting rod |
| | | 31. Fan | 45. Needle bearings |
| | | | 46. Crankpin bearing |

If piston ring locating pins in piston grooves are worn to half their normal thickness, reject the piston.

When piston and rings unit is assembled to connecting rod, the side of the piston which has the piston ring locating pins should be on the intake (away from exhaust side) of the cylinder. Always use new piston pin retaining snap rings when re-assembling piston to connecting rod. All wearing parts of the engine are supplied as replacements in standard size only.

CYLINDER. Cylinder bores are chrome plated. This plating is light grey in color and does not have the appearance of ordinary polished chrome. Because the coating is honed after plating, it looks much like the base metal of the aluminum cylinder. If the plating has been penetrated by scoring or other causes, the soft aluminum underneath will appear as a much brighter area than the unpenetrated chrome surface. These bright areas usually (but not always) are located at the edges of the exhaust ports. If further checking, as mentioned below, shows that the chrome has been penetrated, the cylinder should be rejected.

In some instances, particles of metal from the unplated piston are torn loose and deposited on top of the cylinder plating. This condition is unusually indicated by a rough flaky appearance of the bore and can be removed by using a rubber impregnated grinding wheel on a 1/4-inch electric drill. If a screwdriver can be run over the cleaned surface without leaving marks thereon, the chrome is intact and the cylinder is fit for further service. If the screwdriver scratches the surface, reject the cylinder.

CRANKSHAFT, BEARINGS AND SEALS. If shaft has damaged threads or enlarged keyways or if "run out" exceeds 0.003, re-

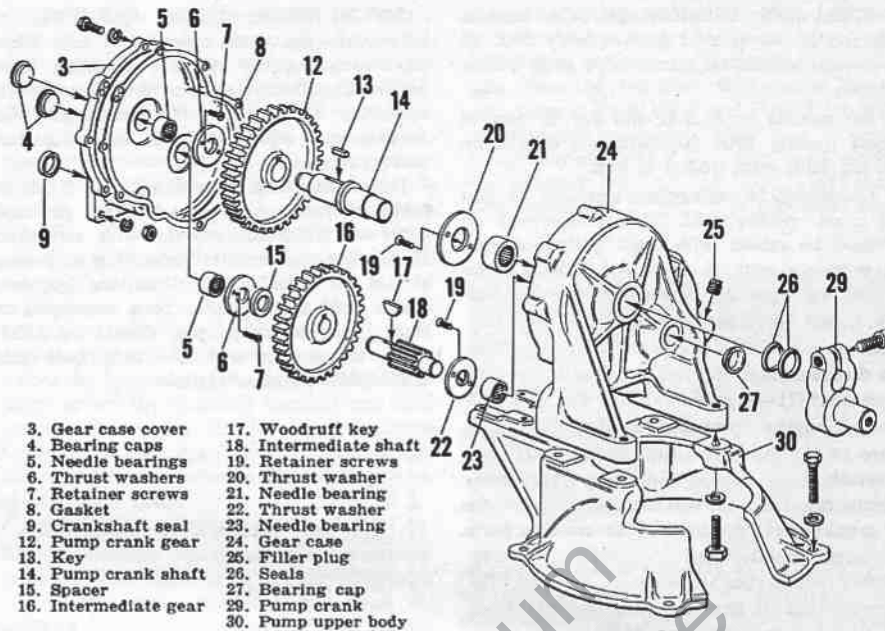

- 3. Gear case cover
- 4. Bearing caps
- 5. Needle bearings
- 6. Thrust washers
- 7. Retainer screws
- 8. Gasket
- 9. Crankshaft seal
- 12. Pump crank gear
- 13. Key
- 14. Pump crank shaft
- 15. Spacer
- 16. Intermediate gear
- 17. Woodruff key
- 18. Intermediate shaft
- 19. Retainer screws
- 20. Thrust washer
- 21. Needle bearing
- 22. Thrust washer
- 23. Needle bearing
- 24. Gear case
- 25. Filler plug
- 26. Seals
- 27. Bearing cap
- 29. Pump crank
- 30. Pump upper body

Fig. HL53—Exploded view of drive gear case for diaphragm type pump; refer to Fig. HL54 for exploded view of the pump assembly. Pinion machined on rear end of engine crankshaft engages the intermediate gear (16); pinion on shaft (18) drives crank gear (12).

ject the shaft. Journals for roller type bearings must be free of pits, galling or heavy score marks. If they are "out of round" or worn more than 0.001 reject the shaft.

If any needle roller shows wear or any visible flat spot, or if rollers can be separated more than the width (or diameter) of one roller, reject all of the rollers. If annular ball bearing feels "lumpy" when rotated, or has perceptible wear, reject the bearing.

Suitable pullers, pushers and mandrels (available from the Homelite Company) should be used in removing and installing main and connecting rod bearings.

Crankshaft seals must be maintained in first class condition because crankcase compression leakage through seals causes a loss of power.

Centrifugal pumps must be disassembled to remove crankshaft from crankcase; refer to CENTRIFUGAL PUMPS paragraph.

CRANKCASE. Be sure that all passages through the crankcase are clean. This is especially true of the idle passage line (in the front half crankcase) which enters the crankcase via the intake valve register. This passage is sometimes restricted by carbon deposits which can be cleaned with a piece of wire. The same holds true of the passage for the fuel tank pressure line (on models with pressurized fuel tank) or the actuator line on pump equipped engines.

If main bearing bores have a lapped appearance, the bearing has been turning in the crankcase in which instance the bearing and/or the crankcase should be rejected. On models so constructed, the mating surfaces of two-piece crankcase (Fig. HL50) must be free of all nicks and burrs as neither sealing compound nor gaskets are used at this joint.

Always use new bearing seals when re-assembling engine.

ROTARY VALVE. The combination rotary type inlet valve and governor (Fig. HL45) should be rejected if any of the following conditions are encountered during inspection:

The sealing faces of valve are scored or worn enough to produce a ridge; if spring posts are loose or extend to valve seating surface; if the governor pivot point has started to wear through the surface of the valve.

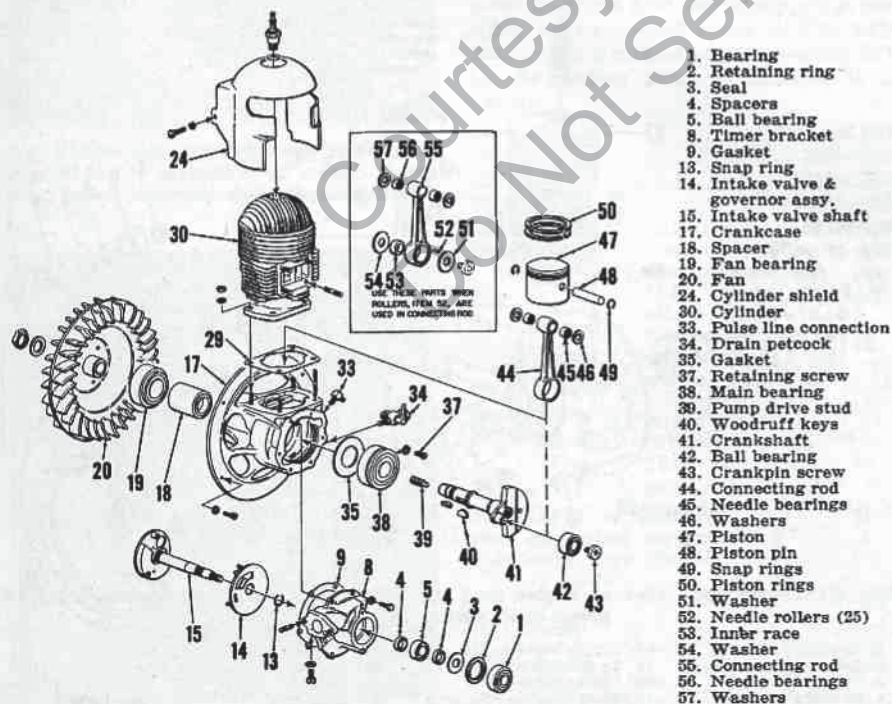

Fig. HL52—Exploded view of engine used on 853 series pumps. Some engines are equipped with needle roller crankpin bearings (see inset) while others have a double-row ball bearing (42) in crankpin end of connecting rod.

Slight scoring of valve may be corrected by lapping on a lapping plate using very fine abrasive. Lapping motion should be in the pattern of a figure eight to obtain best results. Slight scoring of the Formica wear plate is permissible. Homelite recommends soaking a new wear plate in oil for 24 hours prior to installation.

CENTRIFUGAL PUMPS. Refer to exploded view of early type centrifugal pump in Fig. HL56; for later type pumps, refer to Fig. HL31 and HL32 in preceding Homelite section on model 251 engine. The pump must be disassembled and the impeller unscrewed from stud (21—Fig. HL51 or 39—Fig. HL52) in end of engine crankshaft so that the crankcase can be unbolted from pump body and crankshaft be removed from crankcase. Shims are used between impeller and end of crankshaft to maintain minimum clearance between impeller and wear plate (10—Fig. HL56); two shims are normally used. Remove shims if impeller rubs against wear plate when reassembling engine.

If necessary to renew pump seals, proceed as follows: Apply a thin coat of shellac to plain side of ceramic ring (15) and press new washer (16) against ring. Then, apply a thin coat of shellac on washer and press the washer and ceramic ring, washer side in, against and into recess of pump body. Slide seal (14) over hub of impeller with hy-car side of seal towards impeller. Thread impeller onto stud that is screwed into end of crankshaft.

Place the assembled impeller housing (9, 10 and 12) over impeller and in proper engagement with pin (18), press against housing and turn engine. If impeller rubs, remove impeller and discard shim or shims as required from between impeller and crankshaft so that rubbing condition is eliminated. Install assembled impeller housing, then install pump end plate (4) with new gasket (8) and one or two new gaskets (7) as required so that end plate holds impeller housing securely against pump body. Note: End plate should rock slightly before being tightened.

GENERATORS. Generator unit models 9HY-1 and 9HY-1A are similar to the model 251HY 35-1 generator unit shown in Fig. HL34 in preceding section on Homelite model 251 engine. Generator unit models 9A115-1A and 9A115/230-1A are constructed similar to the model 251 A35 generator shown in Fig. HL33.

For exploded view showing construction of generator models 9A115-1 and 9A115/230-1, refer to Fig. HL57. Identify each generator lead as it is disconnected so that the unit may be reassembled with leads properly connected. To remove armature (21) from engine crankshaft, remove the through bolt (32), then pull armature with pin (Homelite tool No. 22271 cut to proper length) and jackscrew (Homelite tool No. S-394) threaded into outer end of armature shaft.

Fig. HL54 — Exploded view of diaphragm type pump assembly. Pump upper body is (30—Fig. HL53). Refer to Fig. HL55 for pump assembly information.

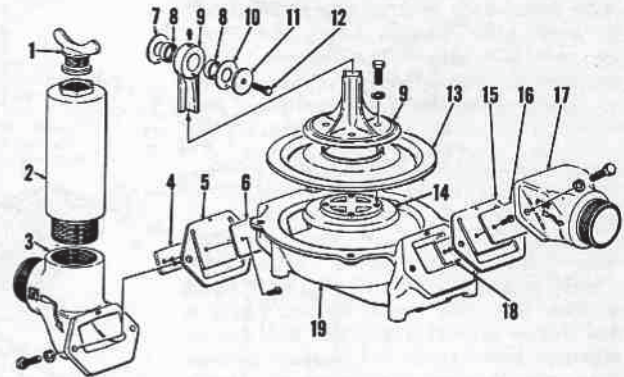

- | | | | |
|--------------------|--------------------|--------------------|-----------------------|
| 1. Plug | 6. Valve plate | 11. Washers | 16. Valve plate |
| 2. Stand pipe | 7. Thrust washer | 12. Cap screw | 17. Discharge fitting |
| 3. Suction fitting | 8. Needle bearings | 13. Pump diaphragm | 18. Valve weight |
| 4. Valve weight | 9. Pump rod | 14. Diaphragm cap | 19. Pump lower body |
| 5. Valve | 10. Thrust washer | 15. Valve | |

Fig. HL55 — View showing proper installation of pump diaphragm. Refer to Figs. HL53 and HL54 for exploded views of pump gear box and pump assembly.

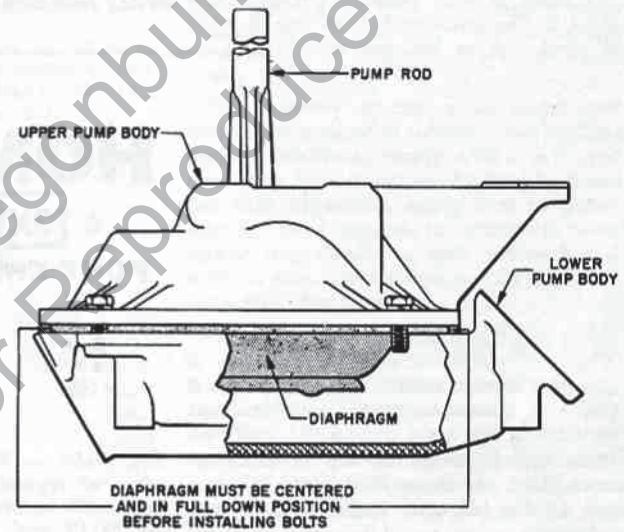
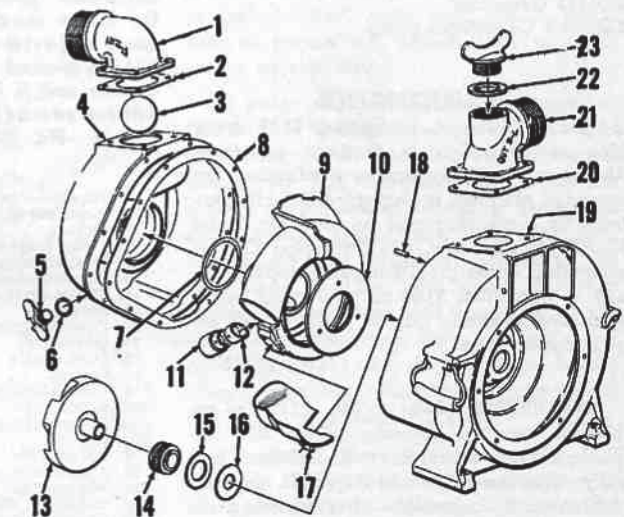

Fig. HL56 — Exploded view of early type centrifugal type pump assembly. Pump impeller (13) is mounted on engine crankshaft. Pump seals (14, 15 & 16) are the later ceramic type; earlier pumps with rubber seal may be converted by installing new impeller (13). Refer to Figs. HL31 and HL32 in preceding section for views of later type pumps.



- | | | | |
|--------------------|----------------------------|------------------|-------------------------|
| 1. Suction fitting | 7. Gasket | 13. Impeller | 19. Pump body |
| 2. Gasket | 8. Gasket | 14. Seal | 20. Gasket |
| 3. Check ball | 9. Impeller housing | 15. Ceramic ring | 21. Discharge fitting |
| 4. End plate | 10. Wear plate | 16. Washer | 22. Gasket |
| 5. Drain plug | 11. Priming tube | 17. Baffle | 23. Priming filler plug |
| 6. Gasket | 12. Auxiliary priming tube | 18. Locating pin | |

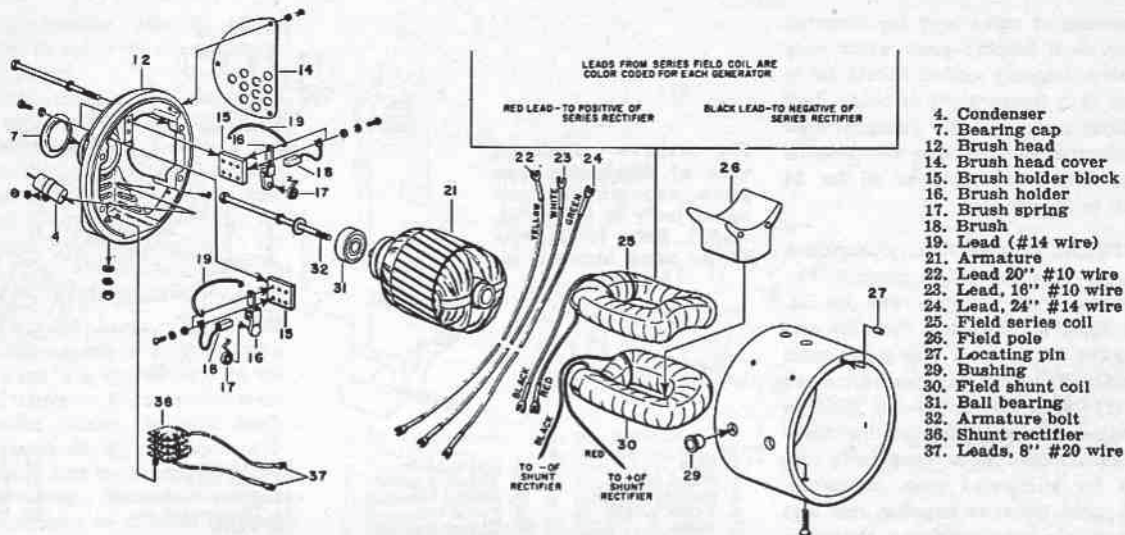

Fig. HL57—Exploded view showing construction of model 9A115-1 and 9A115/230-1 generator units. It will be necessary to remove armature (21) from engine crankshaft to service crankshaft seal, bearing and crankcase.

HOMELITE

A **textron** DIVISION

PORT CHESTER, N.Y. U.S.A.

| ENGINE MODEL | Bore | Stroke | Displacement | Reed Type |
|--------------|-------|--------|--------------|-----------|
| XL-12 | 1 1/4 | 1 3/8 | 3.3 | Flat |
| Super XL | 1 1/8 | 1 3/8 | 3.55 | Pyramid |

This section covers service of Homelite model XL-12 and Super XL engines that are used in the following Homelite tools and equipment.

- XL Brushcutter
- XL100 Circular Saw
- XL120 Circular Saw
- XLA115 Generator
- XLS1 1/2-1 Centrifugal pump

MAINTENANCE

SPARK PLUG. A Champion TJ-8J spark plug or equivalent is used in generator, XL-100 saw and brushcutter application; for extended plug life, a Champion UTJ-11P platinum tip spark plug may be used. On model XL-120 circular saw, use Champion CJ-6 or equivalent spark plug. For pump application, use a Champion TJ-6J or equivalent spark plug. Set electrode gap to 0.025 for all engine applications.

CARBURETOR. Refer to Fig. HL60 for exploded view of Tillotson series HS diaphragm type carburetor with integral fuel pump used on XL-12 and Super XL engines. Carburetor is accessible after removing air box cover (Fig. HL61). **NOTE:** If early type cover gasket becomes damaged when air box cover is removed, install new gasket as follows: Carefully remove old gasket from air box and be sure that surface is free of

Fig. HL60 — Exploded view of typical Tillotson series HS carburetor used on XL-12 and Super XL engines. Carburetor used on generator engine does not have idle fuel mixture adjustment needle (30). On some models, idle speed adjustment screw (34) is located in air box casting and is adjustable without removing cover (8—Fig. HL61).

3. Throttle disc
6. Pump cover
7. Gasket
8. Pump diaphragm
9. Inlet screen
10. Throttle shaft clip
11. Choke shaft & lever
12. Spring
13. Choke friction ball
14. Choke disc
15. Inlet needle
16. Spring
17. Diaphragm lever
18. Lever pin
19. Pin retaining screw
20. Gasket
21. Diaphragm
22. Diaphragm cover
24. Welch plug
25. Retaining ring
26. Channel screen
27. Welch plug
28. Springs
29. Main fuel needle
30. Idle fuel needle
31. Throttle shaft & lever
32. Throttle spring

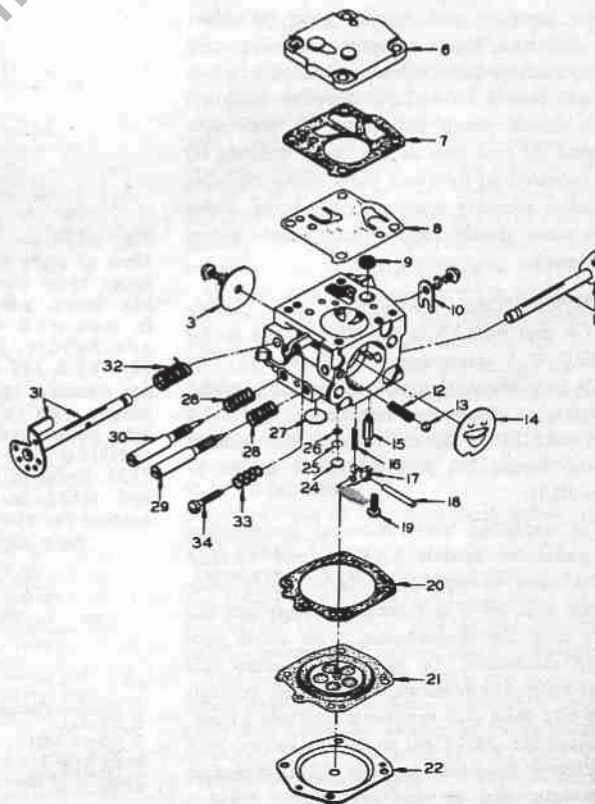

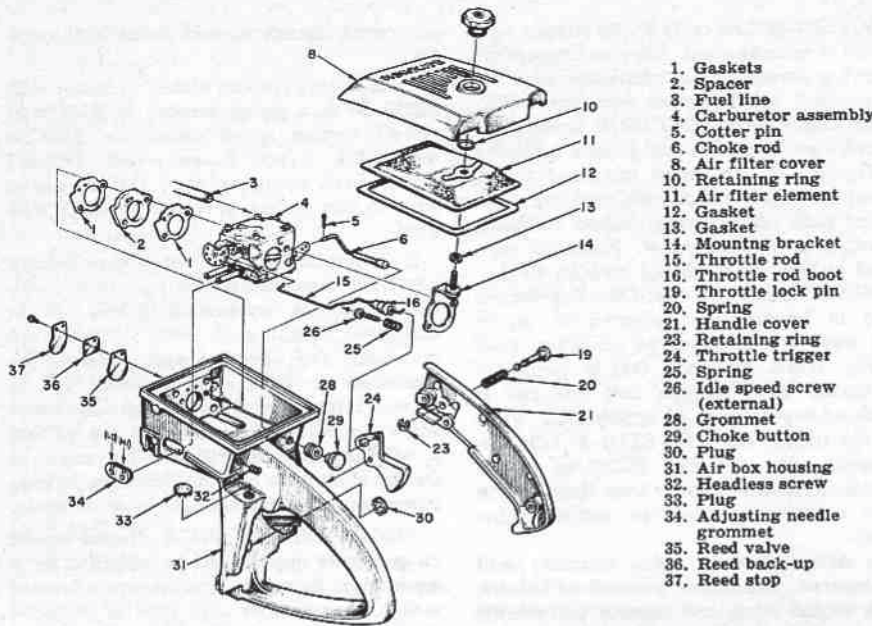

Fig. HL61—Exploded view of handle and air box assembly used on early XL100 saw; model XL120 handle and air box assembly is shown in Fig. HL61A. Late model XL-100 has air vane governor similar to that shown in Fig. HL61A. Refer to Figs. HL62 and HL63 for differences in brushcutter, generator and pump air box construction.

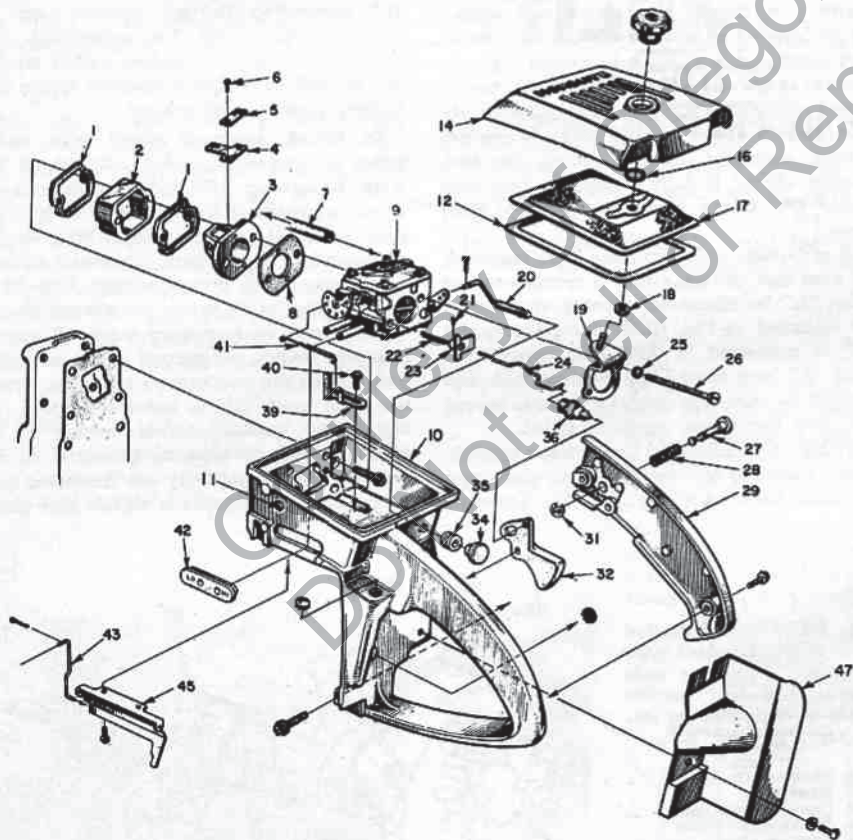

Fig. HL61A—Exploded view of model XL-120 air box and handle. Late model XL-100 is similar except that a flat reed intake valve is used as shown in Fig. HL61. Note the Super XL engine pyramid reed valve assembly (items 1 through 6). Tension of governor spring is adjusted by loosening screw (40) and moving speed adjusting plate (39); refer to text.

- | | | | |
|----------------------|-------------------------|--------------------------------|------------------------------|
| 1. Gaskets | 12. Cover gasket | 24. Throttle rod | 35. Grommet |
| 2. Spacer | 14. Air box gasket | 25. Lock washers | 38. Choke rod boot |
| 3. Reed valve seat | 16. Snap ring | 26. Carburetor mounting screws | 39. Speed adjusting plate |
| 4. Valve reeds | 17. Filter element | 27. Throttle lock pin | 40. Plate retaining screw |
| 5. Reed plates | 18. Stud gasket | 28. Lock spring | 41. Governor spring |
| 6. Reed screws | 19. Bracket & stud | 29. Handle cover | 42. Adjusting needle grommet |
| 7. Fuel line | 20. Choke rod | 30. Plug | 43. Governor link |
| 8. Gasket | 21. Set screw | 31. Snap ring | 45. Governor air vane |
| 9. Carburetor | 22. Throttle rod spring | 32. Throttle trigger | 47. Muffler shield |
| 10. Handle & air box | 23. Throttle rod collar | 34. Choke rod button | |
| 11. Plug | | | |

all dirt, oil, etc. Apply "3M" or Homelite No. 22788 cement to new gasket and carefully place gasket, adhesive side down, on lip around air box chamber. On later engines, gasket is bonded to filter element; install new filter element if either gasket or filter is damaged.

When disassembling carburetor, slide the diaphragm assembly towards adjustment needle side of carburetor body to disengage diaphragm from fuel inlet control lever. To remove welch plugs, carefully drill through large plug (27—Fig. HL 60) with a 1/8-inch drill or through small plug (24) with a 1/8-inch drill and pry plugs out with a pin inserted through the drilled hole. Caution should be taken that the drill just goes through the welch plug as deeper drilling may seriously damage the carburetor. Note channel screen (26) and screen retaining ring (25) which are accessible after removing welch plug (24).

Inlet control lever (17) should be flush with metering chamber floor of carburetor body. If not, bend diaphragm end of lever up or down as required so that lever is flush.

On generator engine, make initial carburetor adjustment as follows: Turn fuel adjustment needle in gently until it just contacts seat, then back needle out 1 1/4 turns. For final adjustment, apply load to generator to allow engine to warm up, then slowly turn needle in until engine speed starts to drop. Correct final setting is 1/2-turn open from this point.

On brushcutter, turn idle speed stop screw in until it just contacts throttle lever tab, then turn screw in 1/4-turn further. Turn idle and main fuel adjustment needles in gently until they just contact seats, then back each needle out 1/2-turn. With engine warm and running, adjust idle fuel needle so that engine runs smoothly, then adjust idle stop screw so that engine runs at 2600 RPM, or just below clutch engagement speed. Check engine acceleration and open idle fuel needle slightly if engine will not accelerate properly. Adjust main fuel needle under load so engine will neither slow down or smoke excessively.

On pump engine, set idle stop screw so that it does not interfere with full travel of throttle stop lever. Open idle fuel adjustment needle one turn and leave needle at this setting; all adjustment should be made with main needle. Open main fuel adjustment needle one turn for initial adjustment, be sure pump is filled with water and start engine. Pump water until engine is at full operating temperature, then turn main fuel needle in slowly until engine begins to lose speed under load. Correct final adjustment is 1/2-turn open from this point.

On circular saw, turn idle speed stop screw in until it just contacts throttle stop lever plus 1/4-turn additional. Open both the idle fuel needle and the main fuel needle one turn each. With engine warm and running, adjust idle speed stop screw so that engine runs at just below clutch engagement speed, or about 2600 RPM. Check en-

gine acceleration and open idle fuel needle slightly if engine does not accelerate properly on initial adjustment. Adjust main fuel needle with engine under load so that engine runs at highest practicable speed obtainable without excessive smoke.

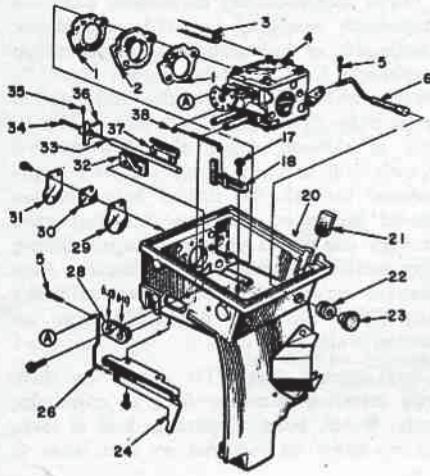

Fig. HL62 — Exploded view of air box assembly used on brushcutter; pump air box is similar except that throttle control parts (items 32 through 37) are not used. Air filter cover and element as shown in Fig. HL61 are used.

- | | |
|-----------------------|-------------------------------|
| 1. Gaskets | 28. Adjustment needle grommet |
| 2. Spacer | 29. Reed valve |
| 3. Fuel line | 30. Reed back-up |
| 4. Carburetor assy. | 31. Reed stop |
| 5. Cotter pins | 32. Clamp spacer |
| 6. Choke rod | 33. Throttle cable casing |
| 17. Screws (2) | 34. Throttle cable |
| 18. Adjusting plate | 35. Set screw |
| 20. Air box | 36. Collar |
| 21. Felt plug | 37. Clamp |
| 22. Grommet | 38. Governor spring |
| 23. Choke button | |
| 24. Governor air vane | |
| 26. Governor link | |

GOVERNOR. The early XL100 circular saw engine is nongoverned. Refer to appropriate following paragraph for information on other units which are equipped with governors.

CIRCULAR SAW GOVERNOR. Refer to exploded view of air box and handle assembly in Fig. HL61A. To adjust governed speed, loosen screw (40) and move slotted speed adjusting plate (39) to obtain desired maximum speed, then tighten screw. Maximum governed no-load speed should be 5000 RPM.

BRUSHCUTTER GOVERNOR. The engine used in brushcutter application is equipped with an air-vane type governor; refer to Fig. HL62. Air vane (24) is connected to throttle shaft through link (26) and is balanced by tension of spring (38). When throttle trigger (62—Fig. HL71) is fully depressed, collar (36—Fig. HL62) on remote control cable moves away from throttle shaft lever allowing governor to control engine speed.

To adjust governor using vibrating reed or electronic tachometer, proceed as follows: With engine warm and running and throttle trigger released, adjust position of collar on remote control cable so that engine slow idle speed is 2500 RPM, or just below clutch engagement speed. Then, when throttle trigger is fully depressed, collar should move away from throttle shaft lever and engine no-load speed should be 6300 RPM. To adjust maximum governed no-load speed, loosen screw (17—Fig. HL62) and move speed adjusting plate (18) as required to obtain no-load speed of 6300 RPM. When adjusting maximum no-load speed, be sure throttle trigger is fully depressed and that collar (36) clears carburetor throttle shaft lever.

If carburetor or linkage has been removed, be sure that governor link is reconnected at hole "A" in carburetor throttle shaft lever as indicated in Fig. HL62. Governor spring (38) is connected to third hole away from hole "A" (two open holes between link and spring). Be sure that governor linkage moves smoothly throughout range of travel.

PUMP GOVERNOR. On pump applications, engine is equipped with air-vane type governor as shown in Fig. HL62; however,

no control linkage is used (items 32 through 37).

With engine running under no load (CAUTION: Be sure pump housing is filled with water), engine speed should be 6400 to 6600 RPM. If not, loosen screw (17) and move speed adjusting plate (18) as necessary so that engine governed speed is 6500 RPM.

If carburetor has been removed or linkage has been disconnected, be sure that governor link (26) is reconnected in hole "A" in carburetor throttle shaft lever. On pump applications, the governor spring should be connected to hole next to hole "A" in throttle shaft lever. Be sure that idle speed screw on carburetor is backed out so that it will not interfere with full movement of throttle shaft lever and that governor linkage moves smoothly throughout range of travel.

GENERATOR GOVERNOR. Engine speed on generator applications is controlled by a mechanical flyweight type governor located within the generator unit; refer to exploded view of generator in Fig. HL70. Slotted end of extension shaft (1) fits over pinned end of carburetor throttle shaft. Centrifugal force of governor weights (64) acting through arms (63) actuate governor cup (40), cam (16) and connecting linkage against force of governor spring (39). The spring (29—Fig. HL63) in air box is adjusted to full tension and is used as a throttle opening spring and to keep slack out of linkage.

To adjust governed speed with tachometer or frequency meter, proceed as follows: To use an RPM indicator, remove receptacle housing (52—Fig. HL70) to gain access to end of generator shaft. With engine at operating temperature, governed no-load speed should be approximately 3750 RPM, or a reading of 63 cycles per second should be indicated on frequency meter. If engine speed or cycles per second is not as specified, loosen the two screws clamping governor shaft guide (10) to bearing, housing (13) and move guide towards engine to increase speed, or towards generator to decrease speed. Note: Only one mounting hole of governor shaft guide is slotted and guide

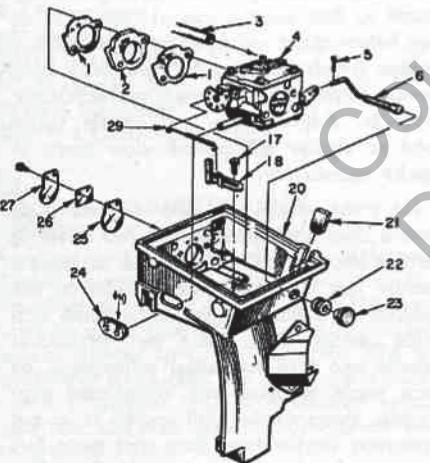
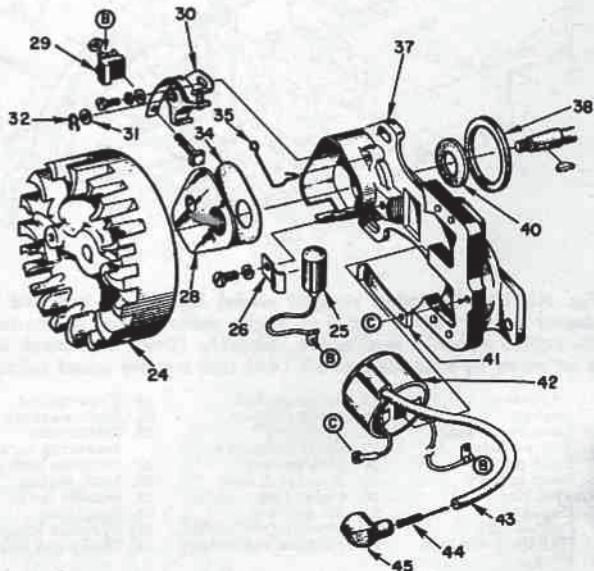

Fig. HL63 — Exploded view of generator engine air box assembly. Mechanical governor parts are shown in exploded view of generator in Fig. HL70.

- | | |
|---------------------|-------------------------------|
| 1. Gaskets | 22. Grommet |
| 2. Spacer | 23. Choke button |
| 3. Fuel line | 24. Adjustment needle grommet |
| 4. Carburetor assy. | 25. Reed valve |
| 5. Cotter pin | 26. Reed back-up |
| 6. Choke rod | 27. Reed stop |
| 17. Screws (2) | 28. Throttle opening spring |
| 18. Adjusting plate | |
| 20. Air box | |
| 21. Felt plug | |

Fig. HL64 — Exploded view of the flywheel type magneto. Connect condenser and low tension leads as indicated by letters "B" and "C".

- | |
|------------------------------|
| 24. Flywheel |
| 25. Condenser |
| 26. Condenser clamp |
| 28. Breaker box cover |
| 29. Terminal block |
| 30. Breaker point set |
| 31. Washer |
| 32. Pivot post clip |
| 34. Gasket |
| 37. Plate and armature assy. |
| 38. Gasket |
| 40. Felt seal |
| 41. Coil retaining clip |
| 42. Ignition coil assy. |
| 43. High tension wire |
| 44. Connector spring |
| 45. Spark plug boot |



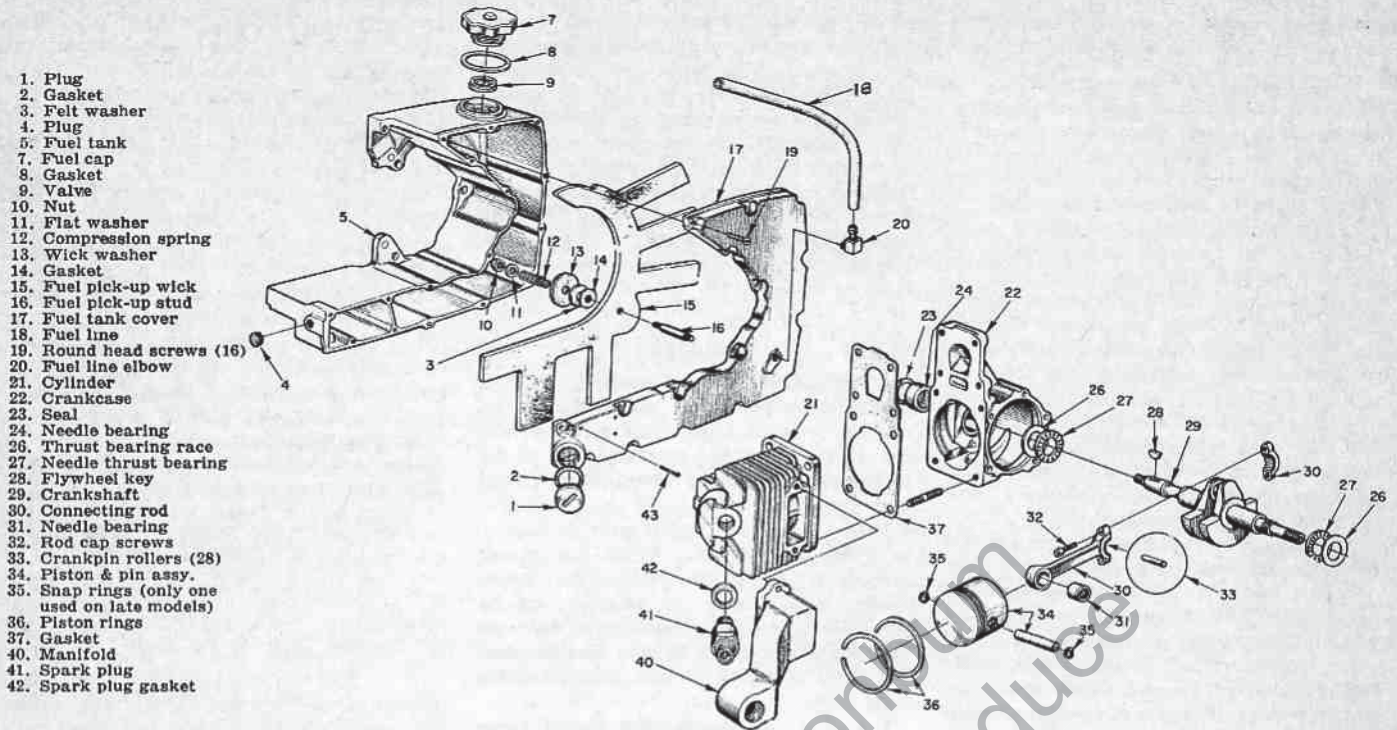

Fig. HL65 — Exploded view of typical XL-12 engine assembly. Crankcase side cover, needle roller main bearing and the crankshaft seal are a part of the circular saw, pump, generator or brushcutter assembly as shown in Fig. HL68, HL69, HL70, or HL71. Saw, pump, generator or brushcutter must be disassembled to gain access to crankshaft; refer to appropriate unit paragraph.

pivots on opposite screw. Tighten screws when proper speed is obtained.

If carburetor has been removed, reconnect throttle opening spring as indicated in Fig. HL63. If plate (18) has been removed, reinstall screws loosely, push plate to apply as much spring tension as possible (to end of slot) and tighten screws. Servicing of the mechanical governor unit requires disassembly of the generator unit; refer to exploded view in Fig. HL70, and to GENERATOR paragraph.

MAGNETO. A Wico flywheel type magneto with external armature and ignition coil is used. Breaker points and condenser are located behind flywheel.

Armature core and stator plate are riveted together and are serviced only as a unit. Stator plate fits firmly on shoulder of crankcase; hence, armature air gap is non-adjustable.

Magneto stator plate has slotted mounting holes, and should be rotated as far clock-

wise as possible before tightening mounting screws to obtain correct ignition timing of 30 degrees BTDC. Set breaker point gap to 0.015. Condenser capacity should test 0.16-0.20 mfd. **CAUTION:** Be careful when installing breaker points not to bend tension spring any more than necessary; if spring is bent

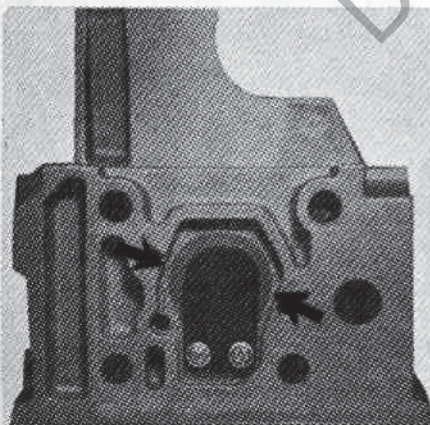

Fig. HL66 — When installing reed valve, reed back-up and reed stop, be sure reed is centered between two points indicated by black arrows.

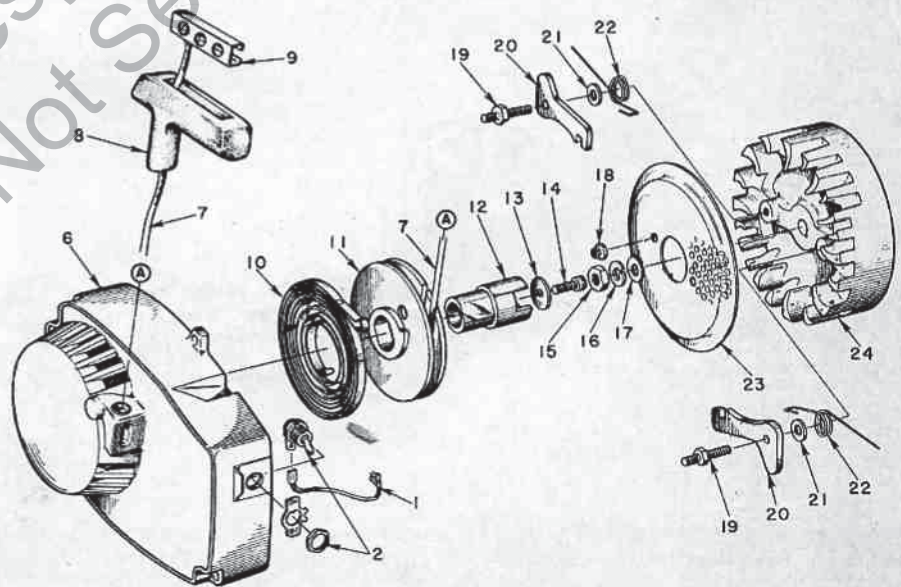

Fig. HL67 — Exploded view of the rewind starter and blower housing assembly. Starter pawls (20) are mounted on engine flywheel (24). Ignition switch wire (1) is connected to magneto breaker terminal (29—Fig. HL64) at "B".

- | | | | |
|---------------------|-----------------------|------------------|---------------------|
| 1. Grounding switch | 10. Rewind spring | 15. Flywheel nut | 20. Pawls |
| 2. Nut | 11. Rope pulley | 16. Lock washer | 21. Washers |
| 6. Blower housing | 12. Starter cup | 17. Flat washer | 22. Pawl springs |
| 7. Starter rope | 13. Flat washer | 18. Lock nuts | 23. Rotating screen |
| 8. Rope handle | 14. Socket head screw | 19. Pawl studs | 24. Flywheel |
| 9. Rope lock | | | |

excessively, spring tension may be reduced causing improper breaker point operation.

LUBRICATION. For generator, mix ¼-pint of good grade SAE 30 motor oil to each gallon of regular gasoline. Remove receptacle cover (52—Fig. HL70) from end of generator and apply 4 or 5 drops of oil to the felt washer (47) each 200 hours of operation.

For circular saw, mix ½-pint of good grade SAE 30 motor oil to each gallon of regular gasoline. Keep gear case filled to proper level with SAE 90 gear oil (Homelite part No. 55291-B) as follows: Remove saw blade and working through opening in retractable blade guard (49—Fig. HL68), remove drain plug (1). Remove filler plug (9) and with base plate of saw level, pour oil into filler plug opening until it starts to run out drain plug. Reinstall plugs and blade. Oil in gear case should be changed after each 100 hours of operation.

For pump, mix ½-pint of good grade SAE 30 motor oil with each gallon of regular gasoline. Pump is lubricated by water in pump. CAUTION: Do not start pump engine without filling pump with water.

For brushcutter, mix ½-pint of good grade SAE 30 motor oil to each gallon of regular gasoline. Each 10 hours of operation, squirt a few drops of SAE-30 oil into hole marked "OIL" on underside of upper head casting. Remove driveshaft each 50 hours of operation, clean the shaft and lubricate it full length with a good grade of wheel bearing grease. Lower gear head should be repacked with a good grade of wheel bearing grease after each 50 hours of operation. Note: Do not wash lower head and bearing housing in solvent as this will wash lubricant from the sealed ball bearings, causing premature bearing failure.

CARBON. Muffler, manifold and cylinder exhaust ports should be cleaned periodically

to prevent loss of power through carbon build up. Remove muffler and scrape free of carbon; a bent wire can be inserted through hole in housing of pump and generator mufflers to clean outer shell. With muffler or manifold removed, turn engine so that piston is at top dead center and carefully remove carbon from exhaust ports with a wooden scraper. Be careful not to damage chamfered edges of exhaust ports or to scratch piston. Do not run engine with muffler removed.

Renew piston if scored, cracked or excessively worn, or if ring side clearance in top ring groove exceeds 0.0035.

Recommended piston ring end gap is 0.070-0.080; maximum allowable ring end gap is 0.085. Desired ring side clearance in groove is 0.002-0.003.

Piston, pin and rings are available in standard size only. Piston and pin are available in a matched set, and are not available separately.

Three different methods have been used to retain piston pin in piston and connecting rod. Early type piston was fitted with a removable snap ring at each end of piston pin. Later piston had a Spirol pin through pin bore at exhaust side of piston and a removable snap ring at intake side. Latest design is a piston fitted with a non-removable wire type snap ring at exhaust side of piston and a Truarc internal snap ring at intake side. Note: Piston ring locating pin is in intake side of piston.

A split piston pin removing tool (Homelite No. A23949) can be used to remove pin from piston fitted with Spirol pin. Remove snap ring from opposite side of piston, fit split end of tool against pin, straddling the Spirol pin, and tap end of pin with mallet to remove pin from piston and connecting rod. On other type pistons, remove the Truarc ring or both early removable type snap rings, then use a ⅜-inch diameter rod to drive pin from piston.

When reassembling, be sure closed end of piston pin is to exhaust side of piston (away from piston ring locating pin).

CRANKSHAFT. The crankshaft is supported in two caged needle roller bearings and crankshaft end play is controlled by a roller bearing and hardened steel thrust washer at each end of the shaft. Refer to Fig. HL65. On generator, crankshaft end

REPAIRS

CONNECTING ROD. Connecting rod and piston assembly can be removed after removing cylinder from crankcase. Refer to Fig. HL65. Be careful to remove all of the 28 loose needle rollers when detaching rod from crankpin.

Renew connecting rod if bent or twisted, or if crankpin bearing surface is scored, burned or excessively worn. The caged needle roller piston pin bearing can be renewed by pressing old bearing out and pressing new bearing in with Homelite tool No. 23756. Press on lettered end of bearing cage only.

Homelite recommends that the crankpin needle rollers be renewed as a set whenever engine is disassembled for service. Stick 14 needle rollers in the rod and remaining 14 needle rollers in rod cap with light grease or beeswax. Assemble rod to cap with match marks aligned, and with open end of piston pin towards flywheel side of engine. Wiggle the rod as cap retaining screws are being tightened to align the fractured mating surfaces of rod and cap.

PISTON, PIN AND RINGS. The piston is fitted with two pinned compression rings.

- 1. Drain plugs
- 2. Drive case
- 3. Needle bearing
- 4. Crankshaft seal
- 5. Needle (main) bearing
- 6. "O" ring
- 9. Filler plug
- 10. Gasket
- 27. Phenolic washer
- 28. Steel washer
- 29. Snap ring
- 30. Extension shaft (clutch adapter)
- 31. Clutch covers
- 32. Clutch shoes (3)
- 33. Clutch spider
- 34. Clutch springs (2)
- 35. Nut
- 36. Cover gasket
- 37. Drivecase cover
- 38. Guard bumper
- 39. Bumper screw
- 44. Blade bolt
- 45. Blade outer washer
- 46. Blade
- 47. Blade inner washer
- 48. Snap ring
- 49. Rotating guard
- 50. Seal
- 51. Seal & brg. retainer
- 52. "O" ring
- 53. Snap ring
- 54. Ball bearing
- 58. Blade shaft
- 59. Driven gear

- 60. Clutch drum & drive gear
- 61. Needle bearing
- 62. Thrust washer
- 63. Inner race

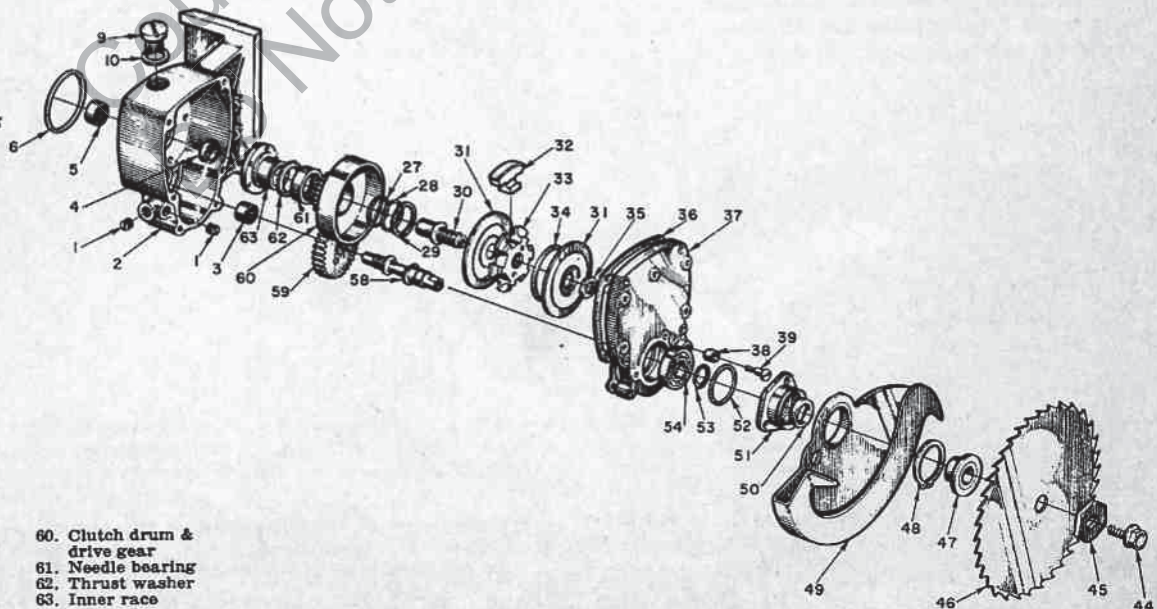

Fig. HL68 — Exploded view of circular saw drive case assembly. Drive case (2) carries crankshaft needle roller bearing (5) and crankshaft seal (4). "O" ring (6) seals drive case to engine crankcase.

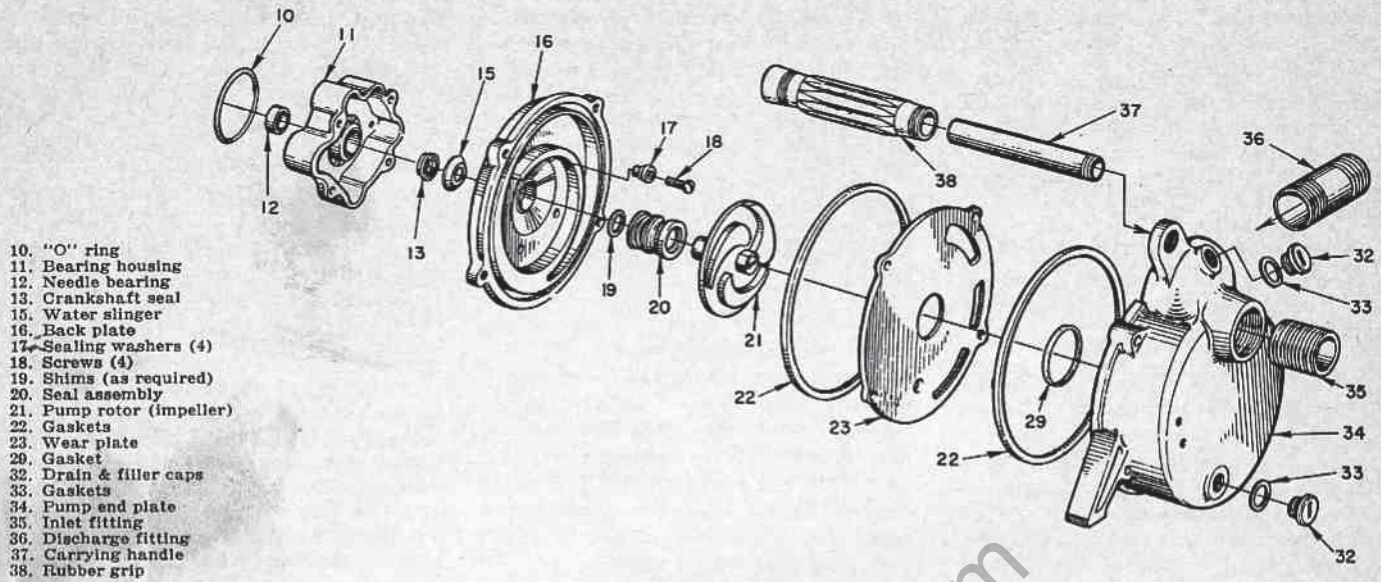

Fig. HL69 — Exploded view of centrifugal pump assembly. Pump rotor (21) must be unscrewed from engine crankshaft and back plate (16) be removed to allow removal of bearing housing (11) and engine crankshaft. Bearing housing retains crankshaft needle roller bearing (12) and crankshaft seal (13).

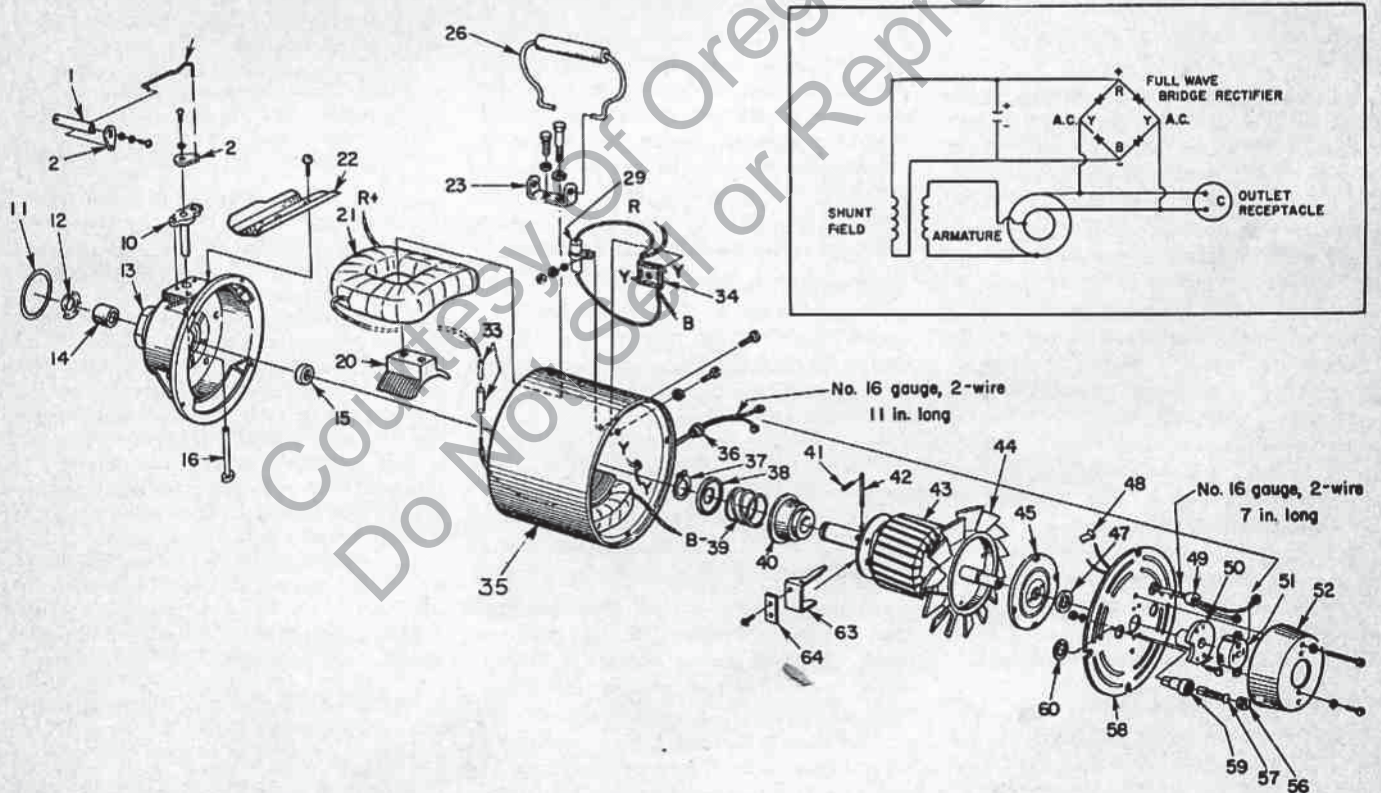

Fig. HL70 — Exploded view of generator assembly. Wiring diagram for generator is shown in upper right corner. Crankshaft needle roller (main) bearing (14) and crankshaft seal (15) are carried in bearing housing (13). Armature (43) must be unscrewed from engine crankshaft to allow removal of bearing housing and crankshaft.

- | | | | |
|-----------------------------|----------------------------|------------------------|----------------------------|
| 1. Throttle shaft extension | 20. Generator field pole | 38. Centering washer | 50. Flanged Oilite bushing |
| 2. Linkage arms | 21. Generator field coil | 39. Governor spring | 51. Outlet receptacle |
| 6. Governor link | 22. Linkage guard | 40. Governor cup | 52. Receptacle housing |
| 10. Governor shaft guide | 23. Handle bracket | 41. Cotter pins (4) | 56. Brush holder cap |
| 11. "O" ring | 28. Carrying handle | 42. Pivot pins (2) | 57. Brush |
| 12. Loading spring | 29. Capacitor | 43. Generator armature | 58. Brush head |
| 13. Bearing housing | 33. Connector | 44. Fan | 59. Brush holder |
| 14. Needle bearing | 34. Rectifier | 45. Collector ring | 60. Holder retaining ring |
| 15. Crankshaft seal | 35. Generator yoke (frame) | 47. Felt washer | 63. Governor arms (2) |
| 16. Governor cam & shaft | 36. Insulating bushing | 48. Brush holder clip | 64. Governor weights (2) |
| | 37. Snap ring | 49. Insulating bushing | |

play is taken up by a loading spring (12—Fig. HL70).

To remove crankshaft, it will be necessary to disassemble the circular saw drive case, pump, generator or brushcutter upper drive housing. Refer to Figs. HL68 through HL71 and appropriate accompanying paragraphs.

CYLINDER. The cylinder bore is chrome plated. Renew the cylinder if chrome plating is worn away exposing the softer base metal.

CRANKCASE, BEARING HOUSING AND SEALS. The needle roller main bearings and crankshaft seals in crankcase and bearing housing can be renewed using Homelite tool Nos. 23757 and 23758. Press bearings and seals from crankcase or bearing housing with large stepped end of tool No. 23757, pressing towards outside of either case.

To install new needle bearings, use the shouldered short end of tool No. 23757 and press bearings into bores from inner side of either case. Press on lettered end of bearing cage only.

To install new seals, first lubricate the seal and place seal on long end of tool No. 23758 so that lip of seal will be towards needle bearing as it is pressed into place.

To install crankshaft, lubricate thrust bearings (27—Fig. HL65) and place on shaft as shown. Place a hardened steel thrust washer to the outside of each thrust bearing. Insert crankshaft into crankcase being careful not to damage seal in crankcase. Place a seal protector sleeve (Homelite tool No. 23759) on crankshaft and large "O" ring on shoulder of bearing housing. Lubricate seal protector sleeve, seal and needle bearing and assemble bearing housing to crankshaft and crankcase. Use NEW bearing housing retaining screws. Clean the screw threads and apply Loctite to threads before installing screws. CAUTION: Be sure the screws are $\frac{1}{8}$ -inch long, and not $\frac{1}{2}$ or $\frac{3}{8}$ -inch screws; the screw length is critical. Tighten the screws alternately and remove seal protector sleeve from crankshaft. Reassemble circular saw drive case, pump, generator or brush cutter upper drive housing as outlined in appropriate paragraph.

FLAT REED INTAKE VALVE. The reed valve is attached to the carburetor air box as shown in Fig. HL66, and is accessible after removing air box from crankcase.

Check the reed seating surface on air box to be sure it is free of nicks, chips or burrs. Renew valve reed if rusted, pitted or cracked, or if it does not seat flatly against its seat.

The reed stop is curved so that measurement of reed lift distance is not practical. However, be sure that reed is centered over opening in air box and reed stop is aligned with reed.

NOTE: If air box has been removed to service reed valve, inspect gasket (12—Fig. HL61) between air box and crankcase. If gasket is damaged and cylinder is not being removed for other purposes, it is suggested that the exposed part of the old gasket be carefully removed and the new gasket be cut to fit between the air box and crankcase. Also, refer to note in CARBURETOR paragraph in MAINTENANCE section.

REWIND STARTER. To disassemble starter, refer to exploded view in Fig. HL67 and proceed as follows: Pull starter rope out fully, hold pulley (11) and pry rope knot from pulley. Let pulley rewind slowly. Hold pulley while removing screw (14), washer (13) and starter cup (12). Turn pulley counter-clockwise until disengaged from spring, then carefully lift pulley off of starter post. Turn open side of housing down and rap housing sharply against top of work bench to remove spring. CAUTION: Be careful not to dislodge spring when removing pulley as the rapidly uncoiling spring could cause injury.

Install new spring with loop in outer end over pin in blower housing and be sure spring is coiled in direction shown in Fig. HL67. Install pulley (11), turning pulley clockwise until it engages spring. Install starter cup (12) and secure with washer and screw. Insert new rope through handle and hole in blower housing. Knot both ends of the rope and harden the knots with heat or cement. Turn pulley clockwise eight turns and slide knot in rope into slot and keyhole in pulley. Let starter pulley rewind slowly.

Starter pawl spring outer ends are hooked behind air vanes on flywheel in line with starter pawls when pawls are resting against flywheel nut. Pull starter rope slowly when installing blower housing so that starter cup will engage pawls.

CIRCULAR SAW DRIVECASE. Refer to exploded view of circular saw drivecase assembly in Fig. HL68. To gain access to engine crankshaft, the unit must be disassembled as follows:

Drain all lubricating oil from gearbox. Hold hex blade washer (45), unscrew cap screw (44) and remove washer and saw blade. Remove blower housing and starter assembly. Using No. 6 Truarc pliers, remove snap ring (48). Remove bumper screw (39) and bumper (38), disconnect guard return spring and remove rotating guard (49). Remove upper saw guard (not shown) and the bearing retainer (51). Remove snap ring (53) from shaft (58) and remove screws retaining cover (37) to drive case (2). Using Homelite bearing puller, tool No. A-23778, remove ball bearing (54) and cover from shaft.

While holding flywheel with Homelite tool # A-23761, remove nut (35), clutch cover (31) and unscrew clutch rotor using Homelite tool No. A-23696. Remove extension shaft

(30) from crankshaft with a socket head screw (Allen) wrench. Remove snap ring (29) and pull clutch drum (60) from flanged bushing (63). Withdraw driven gear (59) and shaft (58); clamp flat outer end of shaft in smooth jawed vise, if necessary to remove gear from shaft, and unscrew gear.

The drive case can now be removed from engine crankcase. Need and procedure for further disassembly should be obvious from inspection of parts. Reassemble unit by reversing disassembly procedure. Refer to LUBRICATION paragraph for refilling unit with oil.

CENTRIFUGAL PUMP. Refer to exploded view of pump in Fig. HL69. Remove pump end plate (34) and wear plate (23). While holding flywheel, unscrew the pump impeller (21). Remove seal (20), back plate (16), shims (19) and water slinger (15). Bearing plate (11), which carries crankshaft needle roller bearing (12) and seal (13) can then be removed.

When reassembling unit, use all new seals and gaskets. Shims (19) are available in thicknesses of 0.010 and 0.015; install shims to provide minimum clearance between impeller (21) and wear plate (23) without causing impeller to rub against the plate.

Refill pump assembly with water before attempting to start engine. Water in pump is necessary to lubricate pump seal (20).

GENERATOR. Refer to exploded view of the generator unit in Fig. HL70. To gain access to the engine governor unit or engine crankshaft, proceed as follows:

Remove two outside screws holding receptacle cover (52) to brush head (58) and move receptacle assembly aside. Remove brush holder caps (56) and brushes, taking particular care to note position and location of brushes so that they may be reinstalled in same position and location. Remove brush head (58), bearing (50) and felt washer (47). Remove screws retaining collector ring (45) and remove collector ring from fan. Remove fan (44), from armature (43) taking care not to lose the Woodruff key (not shown). Unbolt generator yoke (35) from bearing housing (13) and slide yoke from armature. Using a strap wrench, unscrew the armature from engine crankshaft while holding engine flywheel. Procedure and need for further disassembly is obvious from inspection of unit. After reassembly check adjustment of governor as outlined in GOVERNOR paragraph.

BRUSHCUTTER. To gain access to crankshaft bearing plate (8—Fig. HL71), or engine crankshaft, proceed as follows:

Unbolt upper head (26) from bearing plate and remove brushcutter unit and frame (12). While holding engine flywheel, remove nut (18), spacer (17) and clutch cover (13); then unscrew clutch spider (16) from engine crankshaft. Remove inner clutch cover. Bearing plate can now be removed from engine crankcase. Note: Late models have rigid driveshaft instead of flexible housing (28) shown. To remove nut (78) from blade shaft, insert a $\frac{1}{4}$ -inch steel rod in hole in spindle head to hold shaft from turning.

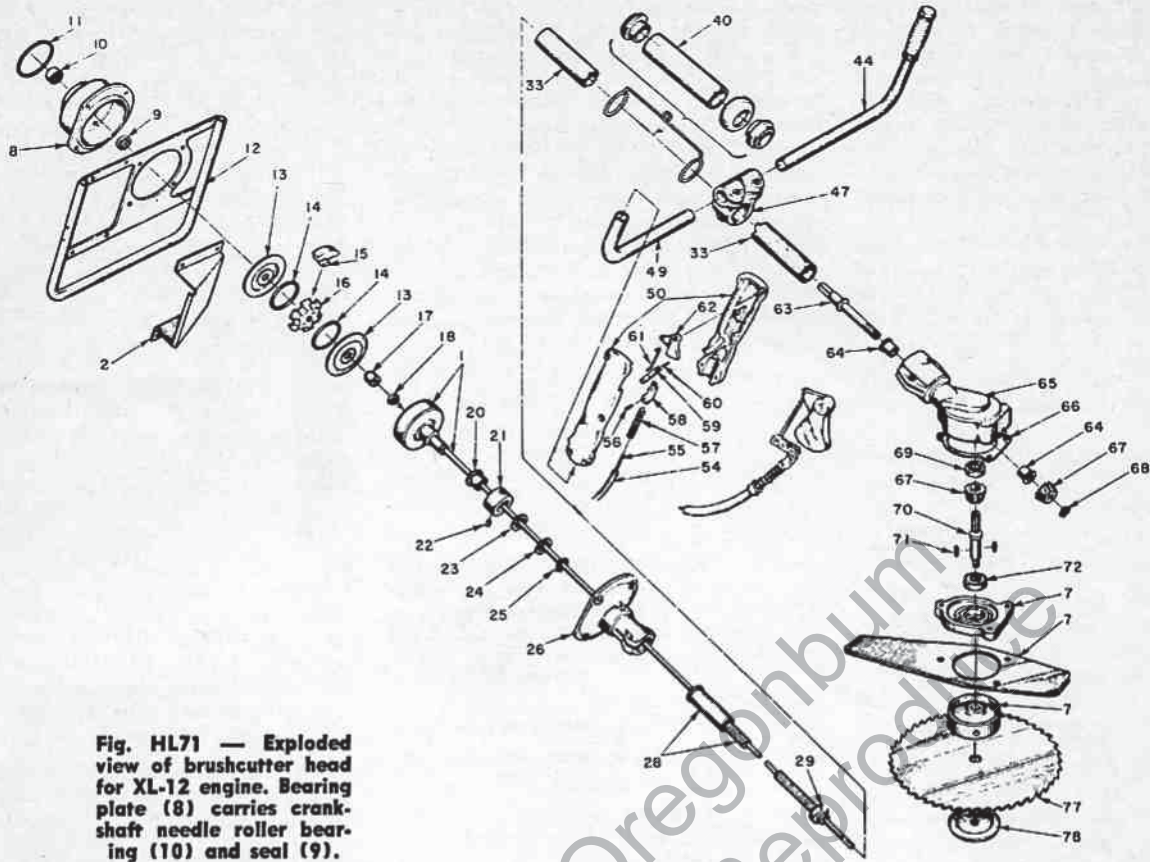

Fig. HL71 — Exploded view of brushcutter head for XL-12 engine. Bearing plate (8) carries crankshaft needle roller bearing (10) and seal (9).

- 2. Exhaust deflector
- 8. Bearing plate
- 9. Crankshaft seal
- 10. Needle roller bearing
- 11. "O" ring
- 12. Frame assembly
- 13. Clutch covers (2)
- 14. Clutch springs (2)
- 15. Clutch shoes (3)
- 16. Clutch spider
- 17. Spacer
- 18. Nut
- 19. Driveshaft & clutch drum
- 20. Flanged bearing
- 21. Collar
- 22. Wick
- 23. Thrust washer
- 24. Spacer
- 25. Snap ring
- 26. Upper head
- 28. Shaft casing
- 29. Split bushing
- 33. Tube
- 40. Hanger tube
- 44. Handle, left
- 49. Handle, right
- 50. Throttle grip
- 54. Throttle cable housing
- 55. Throttle cable
- 56. Set screw
- 57. Return spring
- 58. Cable connector
- 59. Throttle lever
- 60. Pin
- 61. Throttle link
- 62. Throttle trigger
- 63. Gear shaft
- 64. Bearings
- 65. Lower head
- 66. Gasket
- 67. Bevel gear
- 68. Snap ring
- 69. Ball bearing
- 70. Blade shaft
- 71. Keys
- 72. Ball bearing
- 73. Bearing retainer
- 74. Blade guard
- 75. Spindle head
- 77. Saw blade
- 78. Blade shaft nut

HOMELITE
 A **textron** DIVISION
 PORT CHESTER, N.Y. U.S.A.

| MODEL | Bore | Stroke | Displacement |
|-------|--------|--------|--------------|
| XL-88 | 2 1/8" | 1 1/2" | 5.0 |

This section covers service of the model XL-88 Multi-Purpose saw engine and drive components. The saw may be equipped with either an abrasive wheel or saw blade. Caution should be taken that abrasive wheels installed on this unit are rated for spindle speeds of 5000 RPM or higher. When installing saw blade, cutting sides of teeth at bottom of blade are towards engine.

MAINTENANCE

SPARK PLUG. A Champion model CJ-6 spark plug is used. For heavy duty operation, a Champion HO-8A platinum tip or UJ-11-G gold palladium tip spark plug can be used, though it will be necessary to pull the plug wire further out of the retaining clip in air box. Set electrode gap to 0.025 on all models.

CARBURETOR. A Tillotson series HS-46A diaphragm type carburetor with integral fuel pump is used. Refer to Fig. HL75 for exploded view.

For initial adjustment, back idle speed adjustment screw (see Fig. HL76) out until it clears throttle stop, then turn screw in until it contacts stop plus 3/4-turn additional. Open idle mixture adjustment (LO Speed)

needle and main mixture adjustment (HI Speed) needle one full turn each.

Make final adjustments with engine warm and running. Adjust idle mixture needle so that engine idles smoothly; then, adjust idle speed screw so that engine idles at just below clutch engagement speed (2400-2600 RPM). Readjust idle mixture if necessary.

To set main mixture adjustment needle,

open throttle and apply normal load, then adjust main needle for best running and highest speed obtainable; then close needle 1/8-turn from this setting. Note: Governor will limit speed to about 5000 RPM. With main mixture needle so adjusted, check engine acceleration. If engine will not accelerate smoothly, open main mixture needle a small amount at a time until engine will accelerate smoothly.

When servicing carburetor, refer to Figs. HL77 through HL79 as well as to exploded view in Fig. HL75. Slide screen (9—Fig. HL77) from bore to clean or renew. If pass-

ages are choked, plugs (24 and 27—Fig. HL78) may be removed for cleaning purposes. Drill a 1/8-inch hole through large plug (27) and a 1/16-inch hole through small (nozzle) plug, then pry plugs from bores. Note: Carefully drill the holes so as not to damage carburetor body; drill should be controlled so that it will just break through the plug. Install new Welch plugs after cleaning carburetor. Refer to Fig. HL79 and bend diaphragm lever as shown, if necessary, so that lever is flush with floor of diaphragm chamber as shown by dotted line. **MAGNETO.** The model XL-88 is equipped

with a Wico breakerless solid state magneto; refer to exploded view of magneto in Fig. HL81.

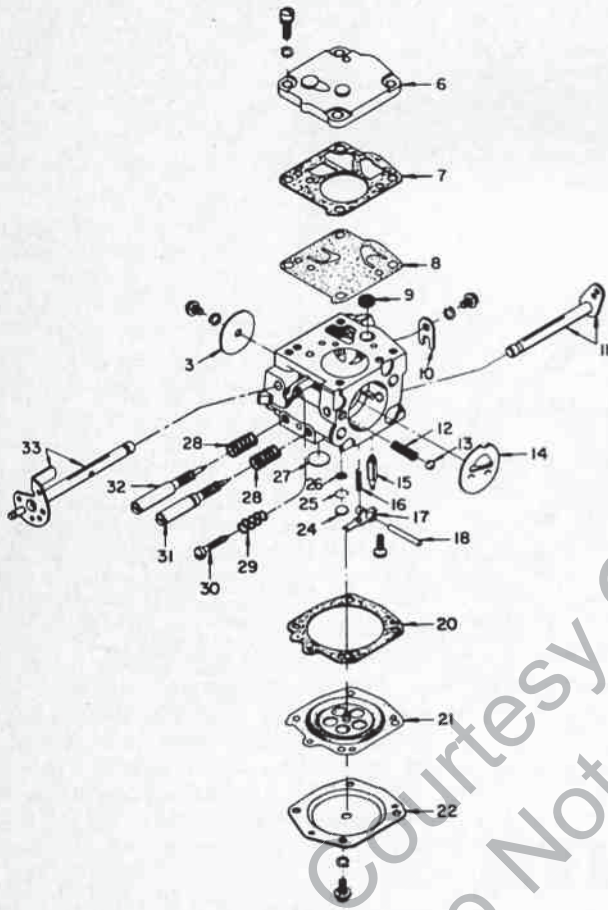

Fig. HL75 — Exploded view of Tillotson series HL carburetor used on model XL-88 saw. Refer also to Figs. HL76 through HL80.

3. Throttle disc
6. Diaphragm cover
7. Gasket
8. Pump diaphragm
9. Filter screen
10. Retainer
11. Choke shaft
12. Detent spring
13. Choke detent ball
14. Choke disc
15. Inlet valve
16. Lever spring
17. Diaphragm lever
18. Pivot pin
19. Pin retaining screw
20. Gasket
21. Metering diaphragm
22. Diaphragm cover
24. Expansion plug
25. Retaining ring
26. Channel screen
27. Expansion plug
28. Main fuel needle
29. Springs
30. Main fuel needle
31. Throttle return spring
32. Throttle shaft

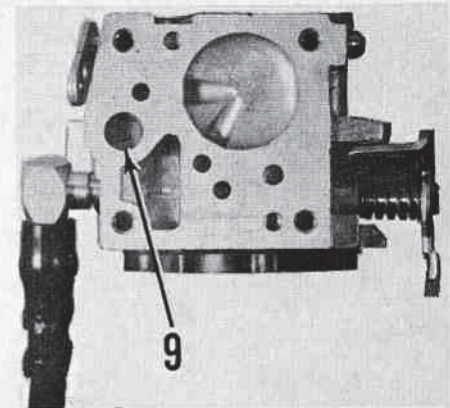

Fig. HL77 — Be sure to clean or renew screen (9) when servicing carburetor.

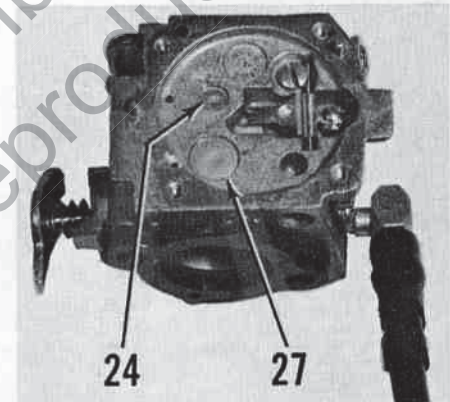

Fig. HL78—View of carburetor showing location of expansion plugs (24 and 27). Channel screen (26—Fig. HL75) is located under plug (24).

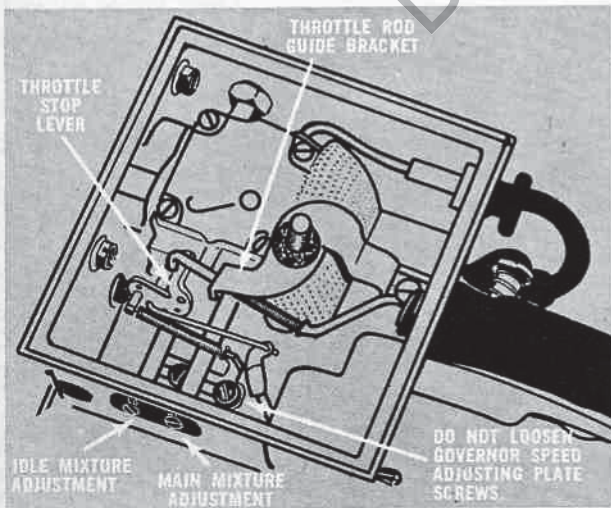
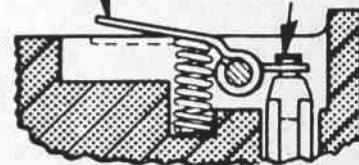

Fig. HL76 — Drawing showing locations of fuel mixture adjustment needles, idle speed needle and throttle stop lever.

DEPRESS HERE THEN PUSH NEEDLE HERE



HIGH



PRY UP HERE

LOW

Fig. HL79—Drawing showing proper adjustment procedure for metering diaphragm lever.

To check the solid state magneto, disconnect spark plug wire, turn ignition switch on and crank engine while holding terminal about 1/4-inch away from ground (engine casting) and check for spark as with conventional magneto. If no spark occurs, refer to the following inspection and test procedure:

Visually inspect rotor (flywheel) for damage. Check for broken or frayed wires.

To test the ignition coil, disconnect the wires at insulating sleeve (39) and test coil according to tester procedure. Specifications for testing with either Graham Model 51 or Merc-O-Tronic tester are as follows:

Graham Model 51:

| | |
|-------------------------|--------|
| Maximum secondary | 10,000 |
| Maximum primary | 1.7 |
| Coil index | 65 |
| Minimum coil test | 20 |
| Maximum gap index | 65 |

Merc-O-Tronic

| | |
|--------------------------|-----|
| Operating amperage | 1.3 |
| Primary resistance: | |
| Minimum | 0.6 |
| Maximum | 0.7 |
| Secondary continuity: | |
| Minimum | 50 |
| Maximum | 60 |

Fig. HL81 — Exploded view of the solid state (breakerless) magneto used on Model XL-88. Trigger switch and condenser (26) are available as assembly only. The trigger coil is moulded into back plate (29).

- 20. Flywheel (rotor)
- 25. Dust cap
- 26. Trigger switch & condenser
- 29. Back plate & trigger coil
- 30. Crankshaft seal
- 31. Roller bearing
- 32. Woodruff key
- 34. Spark plug wire
- 35. Spark plug terminal
- 36. Magneto grounding switch
- 37. "ON-OFF" plate
- 38. Ground lead
- 39. Insulating sleeve
- 42. Coil retaining clip
- 43. Ignition coil

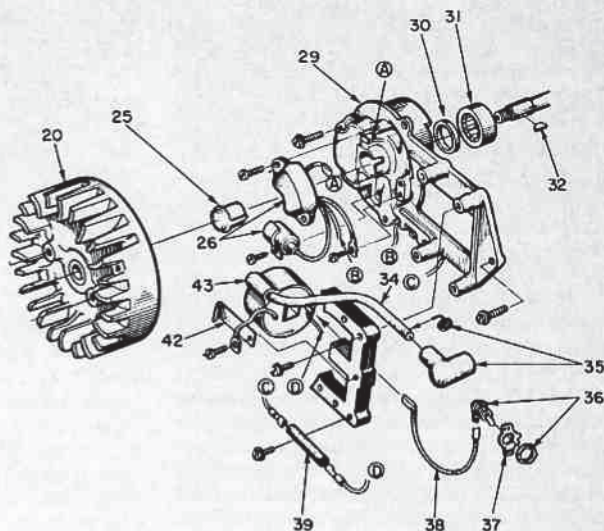

Renew the ignition coil if found faulty and again check for spark. If no spark then occurs or if ignition coil checked OK, proceed as follows:

Remove the flywheel and again check for broken or frayed wires. If no defect is noted, remove the screw attaching condenser to magneto back plate and be sure condenser is not touching back plate or other ground. Push a pin through the condenser lead and using condenser tester, check for short, series resistance and capacity; condenser capacity should be 0.16-0.20 mfd. If condenser is faulty, renew the switch box and condenser assembly (26). If condenser tested OK, proceed as follows:

Disconnect coil primary at insulating sleeve (39) and disconnect switch box ground lead from back plate. Remove the screw attaching condenser to back plate and be sure condenser is insulated from any ground. Be sure the switch box ground lead and ignition coil lead are not touching anything and connect leads of an ohmmeter to the two leads. Meter should read either between 1 megohm and infinity or between 5 and 25 ohms; with ohmmeter leads reversed, reading should be opposite that of preceding test. That is, if first reading obtained was 5-25 ohms, second reading should be 1 megohm to infinity. If ohmmeter readings are not as specified, renew the switch box and condenser assembly. If switch box tested OK, test trigger coil as follows:

Connect one ohmmeter lead to connector between switch box and trigger coil and other ohmmeter lead to back plate (ground). Reading should be either between 0 to 85 ohms or between 85 and 150 ohms. Reverse the leads; second reading on ohmmeter should be opposite first reading. That is, if first reading was in specified range of 0-85 ohms, second reading should be within range of 85-150 ohms. Then, connect the ohmmeter leads to unused terminal of trigger coil and to magneto back plate. Ohmmeter reading should then be 20 to 26 ohms. If trigger coil does not test within specifications, renew the magneto back plate and trigger coil assembly.

When reassembling magneto, check back plate and remove any sharp edges, especially where wires may contact the back plate. Be sure all leads are in place as shown in Fig. HL81. Be sure the back plate

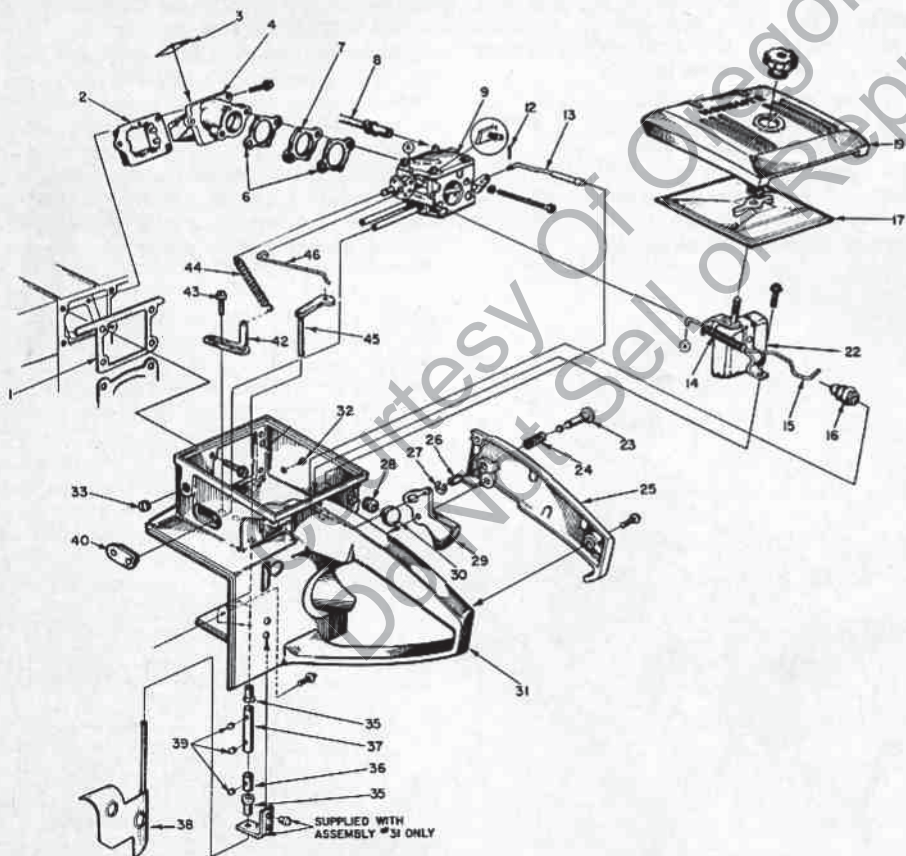

Fig. HL80—Exploded view of Model XL-88 air box and handle assembly. Governed speed is adjusted by loosening screw (43) and moving slotted speed adjusting plate (42). Reed retainer (2) should be installed in engine intake port, then install reed seat (4) with reeds (3).

- 1. Gasket
- 2. Reed retainer
- 3. Valve reeds
- 4. Reed seat
- 6. Gaskets
- 7. Spacer
- 8. Fuel line
- 9. Carburetor
- 12. Cotter pin
- 13. Choke rod
- 14. Return spring
- 15. Throttle rod
- 16. Boot
- 17. Filter element
- 19. Air filter cover
- 22. Air deflector
- 23. Throttle lock pin
- 24. Throttle lock spring
- 25. Handle cover
- 26. Nylon bushing
- 27. Snap ring
- 28. Grommet
- 29. Throttle trigger
- 30. Choke button
- 31. Handle & air box
- 32. Plug
- 33. Bushing
- 35. Bushing
- 36. Collar
- 37. Coupling
- 38. Air vane & shaft
- 39. Set screws
- 40. Grommet
- 42. Speed adjusting plate
- 43. Adjusting plate screw
- 44. Governor spring
- 45. Governor arm & shaft
- 46. Carburetor link

is clean and check all screws for tightness. If there is any doubt about the strength of the rotor (flywheel) magnets, install a new flywheel; be sure to remove "keeper" plates from new flywheel before installing it.

LUBRICATION. Engine is lubricated by oil mixed with fuel. Thoroughly mix oil and gasoline in separate container. Mix ½-pint of Homelite motor oil, or a good grade non-detergent SAE 30 motor oil, in each gallon of regular gasoline.

The clutch drum and sprocket should be removed and the needle roller bearing and inner race be cleaned and greased occasionally.

CARBON. Muffler and cylinder exhaust ports should be cleaned periodically to prevent loss of power due to carbon build up. Remove muffler cover and baffle plate and scrape muffler free of carbon. With muffler cover removed, turn engine so that piston is at top dead center and carefully remove carbon from exhaust ports with wooden scraper. Be careful not to damage the edges of exhaust ports or to scratch piston. Do not attempt to run engine with muffler baffle plate or cover removed.

REPAIRS

CONNECTING ROD. Connecting rod and piston assembly can be removed after removing cylinder from crankcase. Be careful to remove all of the 28 loose needle rollers when detaching rod from crankpin.

Renew connecting rod if bent or twisted, or if crankpin bearing surface is scored, burned or excessively worn. The caged needle roller piston pin bearing can be renewed by pressing old bearing out and pressing new bearing in with Homelite tool

No. 23955. Press on lettered end of bearing cage only.

It is recommended that the crankpin needle rollers be renewed as a set whenever engine is disassembled for service. Stick 14 needle rollers in rod and the remaining 14 needle rollers in rod cap with light grease or beeswax. Assemble rod to cap with match marks aligned and with open end of piston pin towards flywheel side of engine. Wiggle the rod as cap retaining screws are being tightened to align the fractured surfaces.

PISTON, PIN AND RINGS. The piston is fitted with two pinned compression rings. Renew piston if scored, cracked or excessively worn, or if ring side clearance in top ring groove exceeds 0.0035.

Recommended piston ring end gap is 0.070-0.080; maximum allowable ring end gap is 0.085. Desired ring side clearance in groove is 0.002-0.003.

Piston, pin and rings are available in standard size only. Piston and pin are available as a matched set and are not available separately.

Piston pin is retained in piston by a wire type snap ring on exhaust side and by a Truarc snap ring on opposite end. Disassemble piston and rod by removing the Truarc snap ring and pushing pin out with a 1/16-inch diameter pin.

When reassembling piston to connecting rod, be sure closed end of pin is next to wire type snap ring in piston. Install piston pin retaining Truarc snap ring with sharp side out. Rotate snap ring to be sure it is secure in retaining groove, then turn gap toward closed end of piston.

CRANKSHAFT. Flywheel end of crankshaft is supported in a roller bearing in magneto back plate and drive end is supported in a ball bearing located in crankcase. End play is controlled by the ball bearing.

Renew the crankshaft if the flywheel end main bearing or crankpin bearing surface or sealing surfaces are scored, burned or excessively worn. Renew the ball bearing if excessively loose or rough. Also, reject crankshaft if flywheel keyway is beat out or if threads are badly damaged.

CYLINDER. The cylinder bore is chrome plated. Renew cylinder if chrome plating is worn away exposing the softer base metal.

To remove cylinder, first remove the blower (fan) housing, carburetor and air box (handle) assemblies and remove the screw retaining magneto back plate to flywheel side of cylinder. The cylinder can then be unbolted from crankcase and removed from the piston.

CRANKCASE, MAGNETO BACK PLATE AND SEALS. To remove the magneto back plate, first remove the blower (fan) housing and flywheel. Loosen the cylinder retaining stud nuts on flywheel side of engine to reduce clamping effect on back plate boss, then unbolt and remove the back plate assembly from crankcase.

To remove crankshaft from crankcase, first remove the cylinder, connecting rod and piston assembly and the magneto backplate as previously outlined. Remove the drive clutch assembly and the dust shield (26—Fig. HL82). Then, remove the two ball bearing retaining screws (10) from inside of crankcase and remove crankshaft and ball bearing assembly from crankcase. Remove

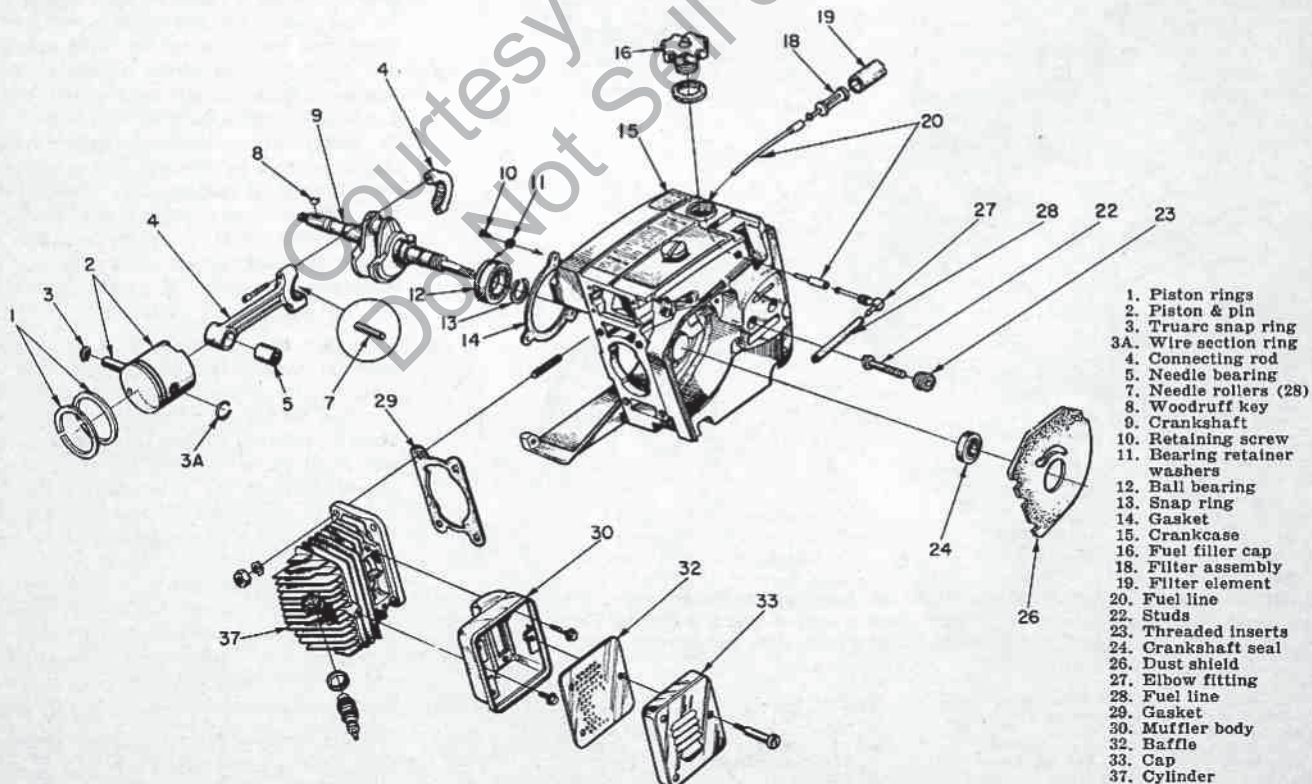

Fig. HL82—Exploded view of Model XL-88 engine assembly. Magneto back plate (29—Fig. HL81) carries magneto end crankshaft main bearing. Saw arm stud retainers (23) must be unscrewed to remove the captive studs (22); do not attempt to unscrew the studs.

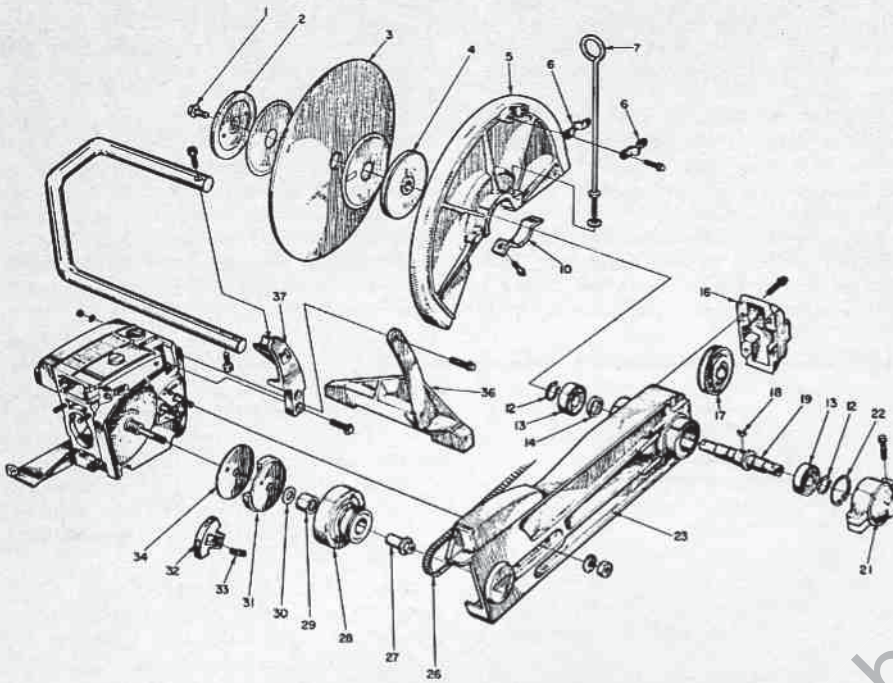

Fig. HL83—Exploded view of drive arm and cutting wheel assembly. Cutting wheel or saw blade can be mounted on either side of arm. Shaft guard (21) is used to cover opposite end of shaft. Belt can be renewed after removing arm from engine and the cap (16) from end of arm.

- | | | | |
|-----------------------|-------------------|--------------------------|------------------------|
| 1. Cap screw | 12. Snap ring | 22. Snap ring | 30. Thrust washer |
| 2. Outer blade washer | 13. Ball bearing | 23. Arm | 31. Spider plate |
| 3. Cutting wheel | 14. Spacer | 24. Drive belt | 32. Clutch shoes |
| 4. Inner washer | 15. Arm cap | 25. Clutch bearing race | 33. Clutch springs |
| 5. Guard | 16. Driven pulley | 26. Clutch drum & pulley | 34. Clutch cover |
| 6. Clamps | 17. Woodruff key | 27. Needle bearing | 35. Saw support |
| 7. Eye or hook bolt | 18. Blade shaft | | 36. Handle bar bracket |
| 10. Guard clamp | 21. Shaft guard | | |

snap ring (13) and press crankshaft from bearing if necessary.

REED VALVES. The pyramid type reed valve seat is made of "Delrin" plastic and reeds are located by pins moulded on seat. The reeds are held in place by a moulded retainer that also serves as a gasket between reed seat and crankcase. Reeds are 0.004 thick.

When installing reed valve assembly, it is important that reed retainer be installed in crankcase first, then install reed seat with reeds in place. Oil can be used to stick reeds to seat. Also, special type shoulder retaining screws must be used.

CLUTCH. To remove the clutch assembly, first remove the blade and arm assembly (see Fig. HL83). The clutch bearing inner

race (27) unscrews counter-clockwise (left-hand threads). Remove inner race with impact wrench, or if impact wrench is not available, use a 3/4-inch socket wrench and strike wrench handle a sharp blow to loosen threads.

Remove clutch drum, pulley and bearing assembly and remove thrust washer (30). Then, unscrew clutch spider plate (31) using a spanner wrench (Homelite tool No. A-23934 or equivalent) in counter-clockwise direction. Remove clutch cover (31).

Inspect clutch drum and pulley for excessive wear or scoring. Inspect all needle bearing rollers for scoring, excessive wear or flat spots, and renew bearing if such defect is noted. Bearing is excessively worn if rollers can be separated more than the width of one roller.

Pry clutch shoes from spider plate with screwdriver. To install new shoes and/or springs, refer to Fig. HL84. Reinstall clutch by reversing removal procedure. Lubricate needle roller bearing in clutch drum with a high temperature grease such as Texaco Unitemp #500 or Humble (Esso) Nebula EP1. Note: The bearing should be cleaned and repacked after each 45 to 50 hours of operation.

BLADE SHAFT, BEARINGS AND PULLEY. Refer to exploded view of unit in Fig. HL83. To renew the shaft (19), bearings (13) or pulley (17), proceed as follows:

Unbolt and remove the arm assembly from engine. Remove shaft guard (21), blade or cutting wheel (3) and blade guard (5). Remove arm cap (16) and drive belt (26). Remove the large internal snap ring (22) from arm and external snap ring (12) from shaft

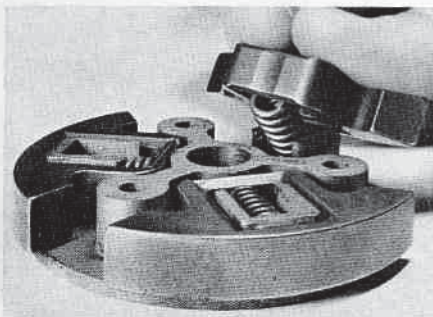

Fig. HL84—Installing shoes and springs on clutch spider plate.

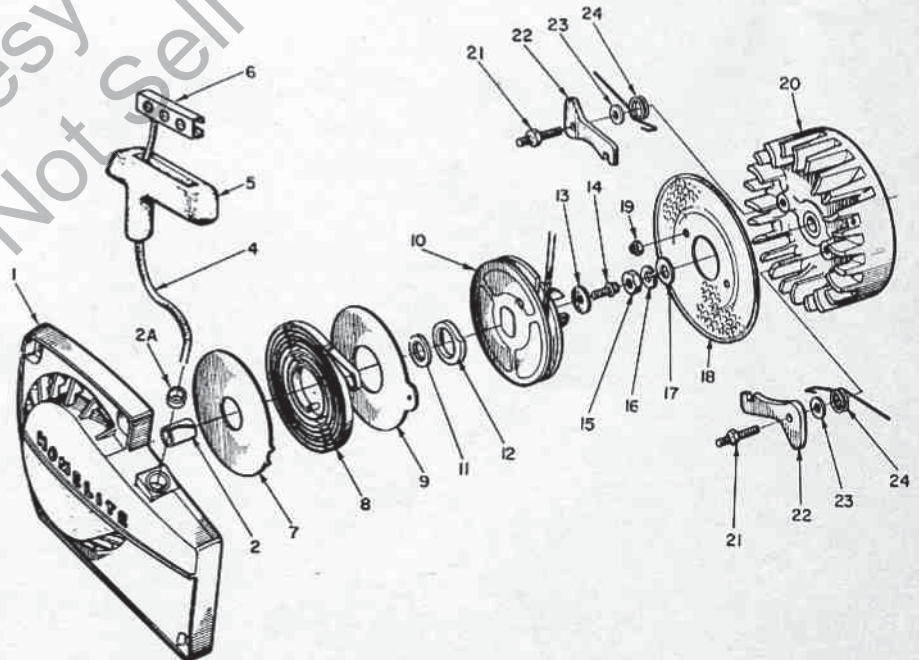

Fig. HL85—Exploded view of the ratchet type rewind starter assembly and engine flywheel.

- | | | | |
|--------------------|-------------------------|---------------------|-----------------------|
| 1. Starter housing | 8. shield | 12. Spring lock | 19. Self-locking nuts |
| 2. Bushing | 9. Rewind spring | 13. Washer | 20. Flywheel |
| 2A. Rope bushing | 10. Outer spring shield | 14. Cap screw | (magneto rotor) |
| 4. Hand grip | 11. Pulley & cup assy. | 15. Flywheel nut | 21. Shoulder studs |
| 5. Insert | | 16. Lock washer | 22. Starter pawls |
| 6. Hand grip | | 17. Flat washer | 23. Washers |
| 7. Inner spring | | 18. Rotating screen | 24. Pawl springs |

at opposite side of arm. Support the arm and press shaft and outer bearing out towards outside of arm. Remove the driven sheave from arm. Press bearing from inner side of arm. Remove snap ring retaining outer bearing to shaft, then press shaft from bearing.

To reassemble, reverse disassembly procedure. Place belt over drive puller on engine, then mount arm to engine crankcase. A wrench with tapered handle (Homelite tool No. A-24085) can be inserted between arm and crankcase to help tension the

drive belt. Be sure belt is tight enough to drive blade or wheel under full cutting load without slippage, then tighten arm retaining nuts.

REWIND STARTER. Refer to Fig. HL85 for exploded view of the ratchet type rewind starter. To disassemble starter after removing housing and starter assembly from engine, proceed as follows:

Pull rope out a short distance, hold rope and pry retainer (6) from hand grip. Untie knot in end of rope, then allow pulley to rewind slowly. Remove hex head screw (14)

and remove rope pulley. **CAUTION:** Be careful not to dislodge spring (8) while removing pulley as the rapidly uncoiling spring could cause injury.

Check all starter parts for wear or other damage and renew as necessary. Rope bushing (2A) in housing should be renewed if rope notch is worn in bushing. When reassembling starter, lubricate starter post lightly and install spring without lubrication. Refer to exploded view in Fig. HL85 for reassembly guide. Pre-wind the spring about 2 to 4 turns.

NOTES

Courtesy Of Oregonbumb
Do Not Sell or Reproduce

NOTES

Courtesy Of Oregonbium
Do Not Sell or Reproduce

HOMELITE AUTHORIZED FACTORY BRANCHES

(Arranged in alphabetical order by states)

When communicating with any of the establishments listed below, insert the name "Homelite" before the listed address, except those in Canada and Europe.

3000 W. Valley Blvd.
Alhambra, California 91803

211 M. Street
Fresno, California 93721

2234 Auburn Blvd.
Sacramento, California 95821

727 Airport Blvd.
So. San Francisco, California 94080

1575 Carr Street
Denver, Colo. 80215

164 E. Service Road
Hartford, Connecticut 06101

6965 Phillips Hwy. (U. S. No. 1 South)
Jacksonville, Florida 32216

4820 South Atlanta Rd.
Smyrna, Georgia 30080

3820 W. North Avenue
Stone Park, Illinois 60161

1818 W. 16th Street
Indianapolis, Indiana 46202

3209 Old Minden Rd.
Bossier City, Louisiana 71010

Park Street
Orono, Maine 04473

144 Western Avenue
Allston, Massachusetts 02134

30425 Stephenson Highway
Madison Heights, Michigan 48071

3781-28th St. S. W.
Grandville, Michigan 49418

814 North Prior Avenue
St. Paul, Minnesota 55104

4115 Pennsylvania
Kansas City, Missouri 64111

5733 Manchester Avenue
St. Louis, Missouri 63110

1433 So. 13th Street
Omaha, Nebraska 68103

1006 St. George Avenue
Avenel, New Jersey 07001

39 River Road
North Arlington, New Jersey 07032

1910 Broadway, N.E.
Albuquerque, New Mexico 87107

1650 William Street
Buffalo, New York 14206

658 New Loudon Road
Latham, New York 12110

Rte. 1, Boston Post Road
Port Chester, New York 10573

2518 Erie Boulevard, East
Syracuse, New York 13224

2640 Freedom Drive
Charlotte, North Carolina 28208

7806 Anthony Wayne Avenue
Cincinnati, Ohio 45216

15728 Industrial Parkway
Cleveland, Ohio 44135

2714 Nebraska Avenue
Toledo, Ohio 43607

1212 S.E. Powell Blvd.
Portland, Oregon 97242

126 Frankstown Ave.
Altoona, Pennsylvania 16602

176 Lincoln Highway
Malvern, Pennsylvania 19355

5025 Longshore Avenue
Philadelphia, Pennsylvania 19135

4260 Ohio River Blvd.
Pittsburgh, Pennsylvania 15202

1324 No. Hollywood
Memphis, Tennessee 38108

1225 No. Industrial Blvd.
Dallas, Texas 75207

113 North Highway 91
North Salt Lake, Utah 84054

4605 Eisenhower St.
Alexandria, Virginia 22304

1911—22nd Avenue, So.
Seattle, Washington 98144

E. 3927 Trent Avenue
Spokane, Washington 99202

5128 MacCorkle Ave., S.E.
Charleston, West Virginia 25304

9010 W. Schlinger Ave.
W. Allis, Wisconsin 53214

556 Main St.
West DePere, Wisconsin 54178

CANADA

Terry Industries,
A Div. of Textron Canada Ltd.
180 Labrosse Avenue
Pointe Claire, Quebec

Terry Industries,
A Div. of Textron Canada Ltd.
37 Densley Avenue
Toronto 15, Ontario

Terry Industries,
A Div. of Textron Canada Ltd.
12—5th Street
P.O. Box 801
Moncton, New Brunswick

Distributors for
Terry Industries are:

Broadway Equipment, Ltd.
98 Broadway
Corner Brook, Newfoundland

H. C. Paul Ltd.
945 King Edward St.
Winnipeg 21, Manitoba

Specialty Equipment
14650—118th Avenue
Edmonton, Alberta

Challenger Equipment Ltd.
14 Powell Street
Vancouver, British Columbia

EUROPE

Homelite, A Div. of Textron Inc.
Biesbosch 79A
Amstelveen, Holland

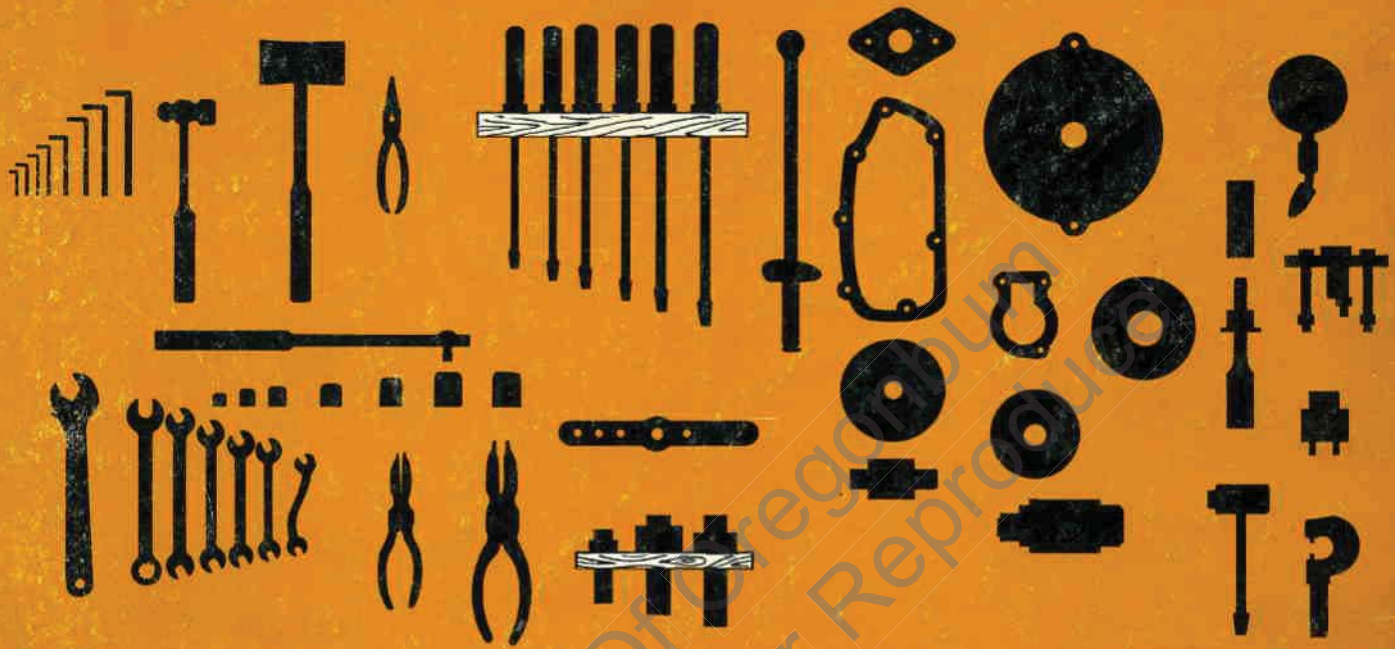

HOMELITE®

A **textron**
DIVISION

PORT CHESTER, N.Y. U.S.A.

IMPORTANT CORRECTIONS

to be made in this copy of the Shop Service Manual

On page 66, column 3: where it says "...adjust as outlined in preceding paragraph for conventional magneto," correct this to read:

Adjust XL 104 breakerless Wico and Phelon CD Ignition system armature-to-flywheel air gap to .008"-.012" using .0125" plastic shim stock, Homelite #24306.

On page 68, column 1 under topic #1 "SPARK PLUG," change the firing gap from .020" to .025".

(For your information only) Why the same thickness plastic shim is used to set the .004" .008" air gap on breaker magneto and .008"-.012" on breakerless ignitions: The core legs of the breaker magneto are small in area, like the high heels of ladies' shoes; the core legs of the breakerless ignition systems are broader, like men's shoe heels, and do not compress the plastic shim stock as much.

Courtesy Of Ores Publications
Do Not Sell or Reproduce