

# Homelite®

## PARTS LIST

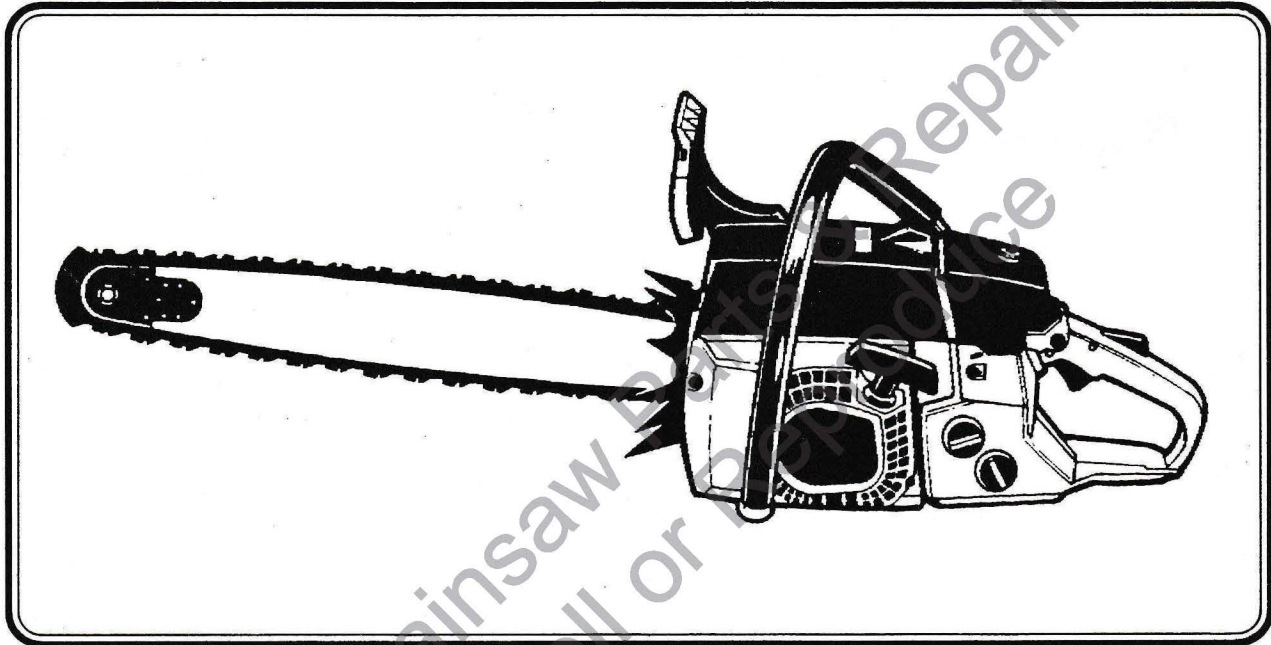

**8800**

**UT10731**

**UT10731 A**

**UT10731 B**

**UT10731 C**

# STARTER - IGNITION - EXHAUST SYSTEM

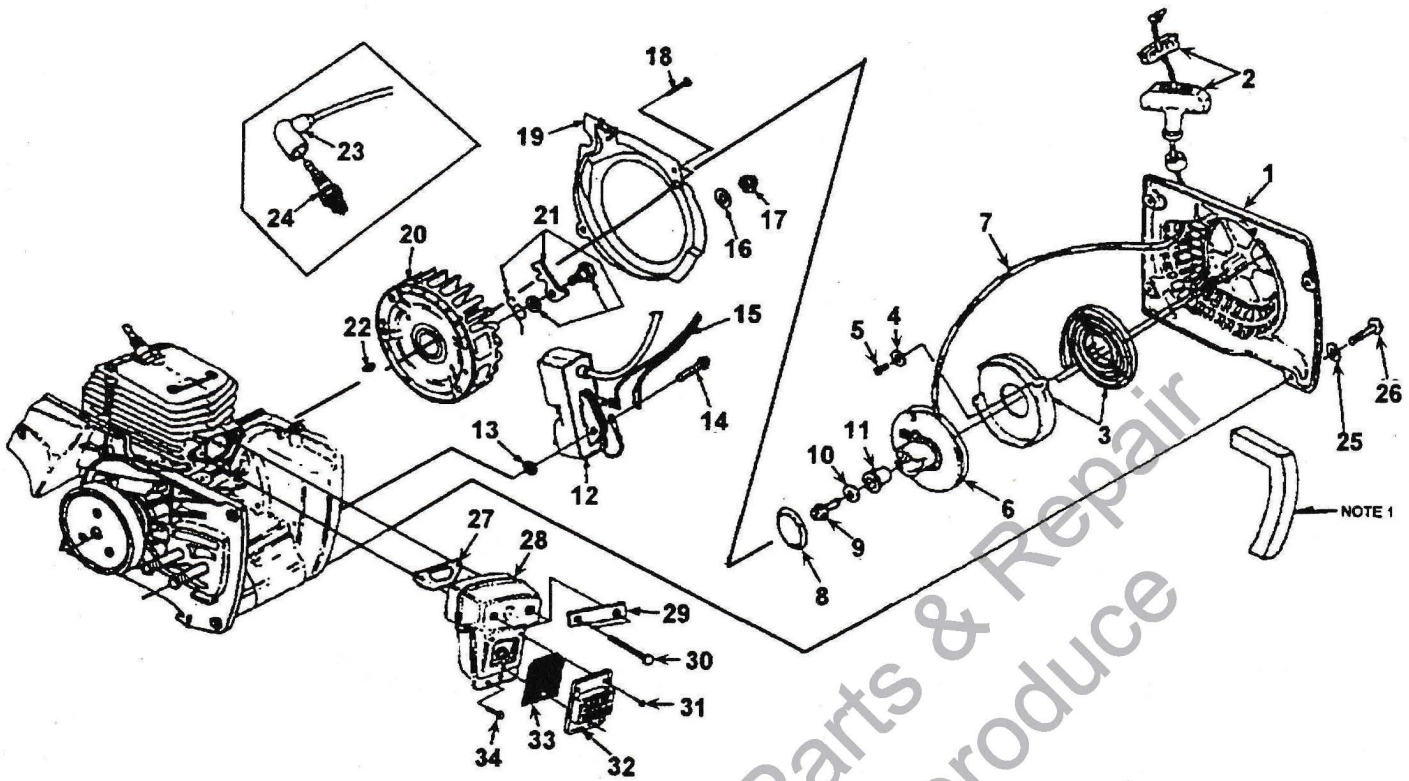

ASSEMBLIES

NO.	PART NO.	DESCRIPTION	QTY.
1	• A 02292 A	STARTER COMPLETE	1
2	A 69962 B	GRIP - W/INSERT	1
3	A 98067 A	SPRING & RETAINER	1
4	84025	WASHER - FLAT (#8)	3
5	82528	SCREW - THREAD FORM (6 X 3/8")	2
6	A 97990 C	PULLEY & ROPE	1
7	A 00518	ROPE	1
8	02505	SPRING - GRIP	1
9	82409	SCREW - (10-14 X 5/8")	1
10	58763	WASHER - RETAINING	1
11	97992 A	BUSHING - STARTER POST	1
12	• A 04890 A	MODULE ASSY	1
13	04617	SPACER	2
14	88052	SCREW - HEX HD (10-24 X 7/8")	2
15	A 98583 1D	LEAD - GROUND W/GROMMET	1
16	95479 A	WASHER - FLAT	1
17	81255	NUT - LOCK HEX (3/8-24)	1
18	80582	SCREW MACH (8-32 X 5/8")	2
19	02133	SCROLL - AIR GUIDE	1
20	• A 02085 B	ROTOR	1
21	A 03610	STARTER PAWL KIT	1
22	75078	KEY - WOODRUFF	1
23	A 33055	TERMINAL - SPARK PLUG	1
24	98217 S	SPARK PLUG (RCJ6Y)	1
25	84003	WASHER - FLAT (#10)	4
26	82562	SCREW - PAN HD (10-24 X 5/8")	4
27	97682 B	GASKET - MUFFLER	1
28	A 04429	MUFFLER	1
29	04431 A	PLATE - RETAINING	1
30	82592	SCREW - HEX CAP (1/4-20 X 3 1/4")	2
31	80560	SCREW - MACH (8-32 X 1/2")	3
32	A 98747	CAP - MUFFLER	1
33	98827	SCREEN - SPARK ARRESTOR	1
34	82555 1	SCREW - TRUSS HD (10-24 X 3/4")	2

Item No	Torque Specs		Required Lockite
	In/Lbs	Nm	
5	8-12	9-1.4	
9	30-40	3.4-4.5	
14	50-60	5.6-6.8	
17	250-300	28.2-33.9	
18	30-40	3.4-4.5	
24	120-180	13.6-20.3	
26	40-50	4.5-5.6	262 Red
30	100-140	11.3-15.8	
31	30-40	3.4-4.5	
34	60-70	6.8-7.9	

NOTE 1: A-03611-A FOAM KIT

# CLUTCH - OIL PUMP

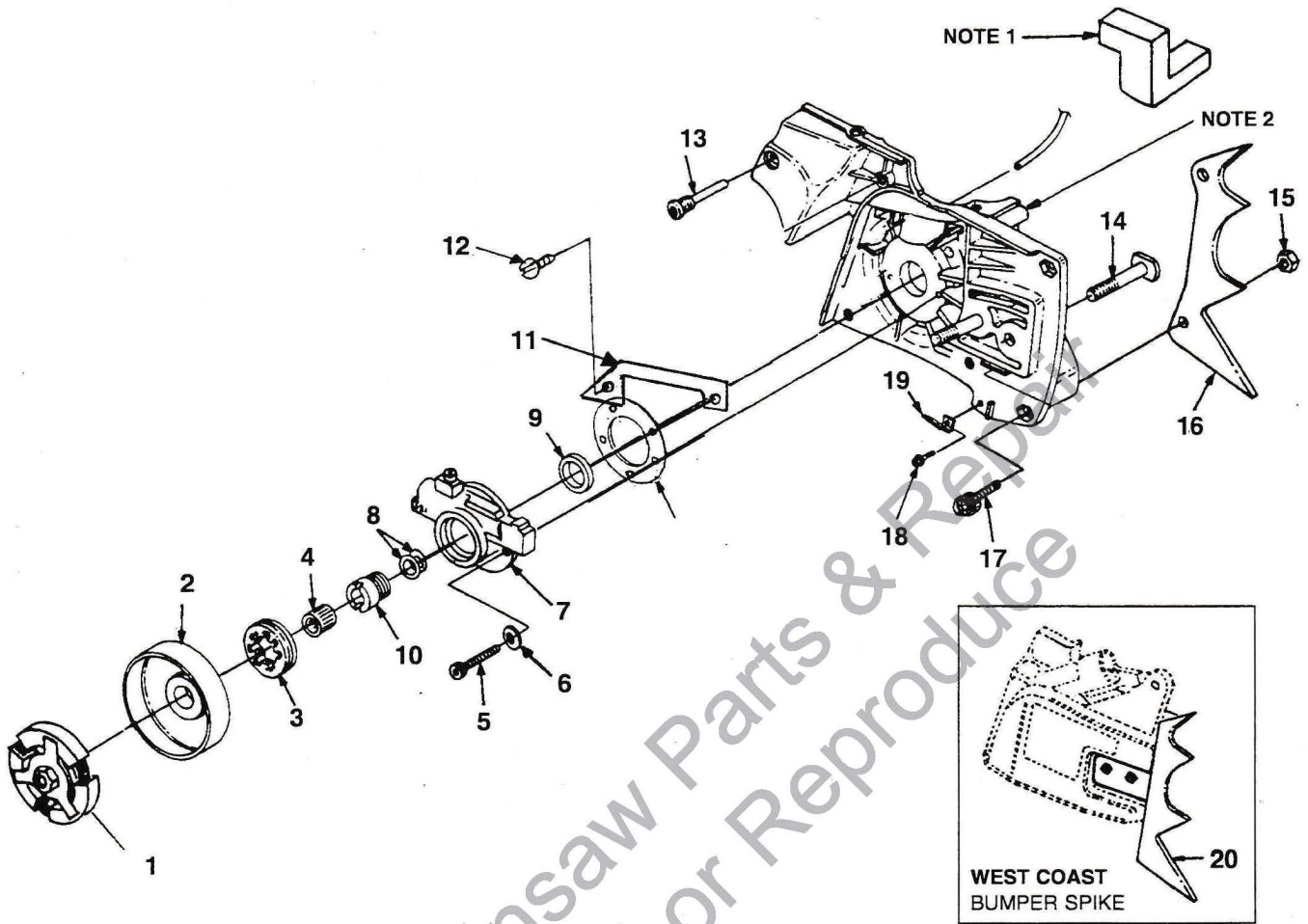

## ASSEMBLIES

NO.	PART NO.	DESCRIPTION	QTY.
1	A 00022 A	CLUTCH	1
2	A 00351 1	DRUM & HUB	1
3	95058 A	SPROCKET (7T X 3/8P)	1
	63285 A	SPROCKET (7T X .404)	1
4	98883	BEARING-Needle	1
5	82562	SCREW-Cap Socket Hd. (10-24 X 7/8")	2
6	84003	WASHER-Flat (#10)	2
7	A 04891	OIL PUMP	1
8	84119	WASHER-Thrust	1
9	58308 B	SEAL-Shaft	1
10	A 00357 A	WORM & BEARING	1
11	04621	SHIELD-Pump	1
12	80575	SCREW-Slotted Hd. (8-32 X 1/4")	2
13	93367	PIN-Isolator	6
14	93918 A	BOLT-Guide Bar (3/8-16 X 2")	2
15	81225	NUT-Hex (#12-24)	2
16	01233	BUMPER SPIKE	1
17	82572	SCREW-SocketCap (12-24 X 5/8")	2
18	96620	SCREW-Torx Hd. (10-24 X 1/2")	1
19	04626	CHAIN-Stop	1
20	A 98969 A	BUMPER SPIKE (West Coast)	1

NOTE 1: A-03611-A FOAM KIT

NOTE 2: See PG. 4, Item #14

Torque Specs			
Item No	In/Lbs	Nm	Required Locktite
5	20-25	2.3-2.8	262 Red
12	30-40	3.4-4.5	242 Blue
13	60-70	6.8-7.9	
17	Hand Tight		
18	50-60	5.6-6.8	

# ENGINE INTERNAL

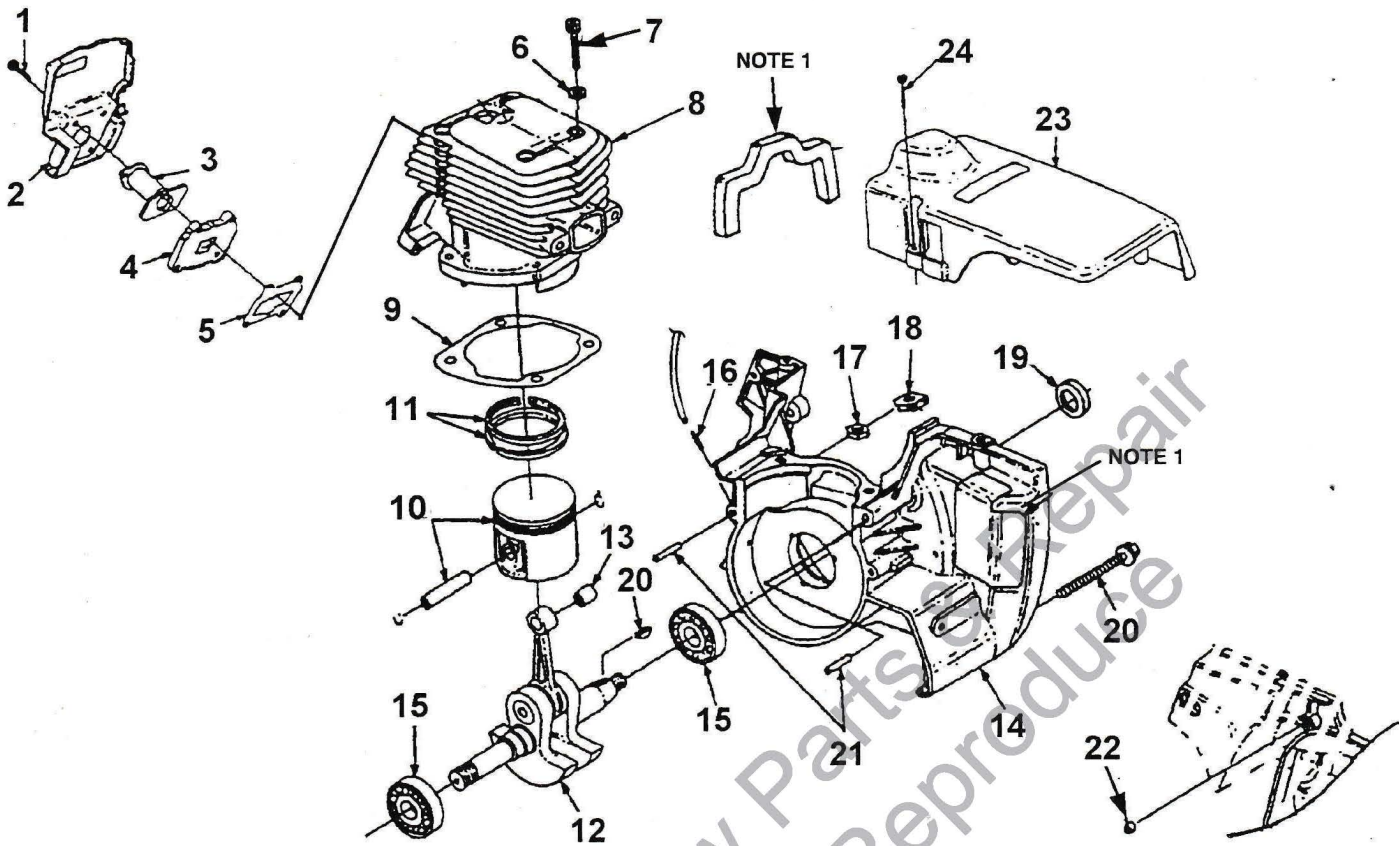

● ASSEMBLIES

NO.	PART NO.	DESCRIPTION	QTY.
1	82248	SCREW - MACH. HEX HD (8-32 X 3/4")	1
2	97338 1A	BAFFLE - CYLINDER	1
3	97263 2	BOOT - INTAKE	1
4	02822	ADAPTER - INTAKE	1
5	04635	GASKET - INTAKE	1
6	12021	WASHER - CONICAL (#10)	4
7	82246	SCREW - CAP SOCKET (10-24 X 1")	4
8	● A 02830 A	CYLINDER & PISTON (MATCHED)	1
9	97316	GASKET - CYLINDER	1
10	● A 02824 1B	PISTON & PIN ASSY.	1
11	02825	PISTON RING	2
12	● A 00792 A	CRANKSHAFT & ROD	1
13	93519	BEARING - NEEDLE	1
14	● A 07082	CRANKCASE ASSY	1
15	94621 A	BEARING - BALL	2
16	69833	FITTING - TUBE	1
17	81208	NUT - LOCK HEX (10-24)	2
18	12689 A	NUT - RETAINER	2
19	58308 B	SEAL - SHAFT	1
20	88057	SCREW - HEX SEMS (10-24 X 2")	5
21	31062	PIN - DOWEL	1
22	97330	BUSHING	1
	93918 A	BOLT - GUIDE BAR (SEE CLUTCH PG)	2
23	● A 02121	COVER - CYLINDER	1
24	93397 A	SCREW - CYLINDER COVER	3

Item No	Torque Specs		Required Locktite
	In/Lbs	Nm	
1	15-25	1.7-2.8	242 Blue
7	80-90	9.0-10.2	262 Red
20	70-80	7.9-9.0	262 Red
24	20-30	2.3-3.4	

NOTE 1: A-03611-A FOAM KIT

# ENGINE HOUSING

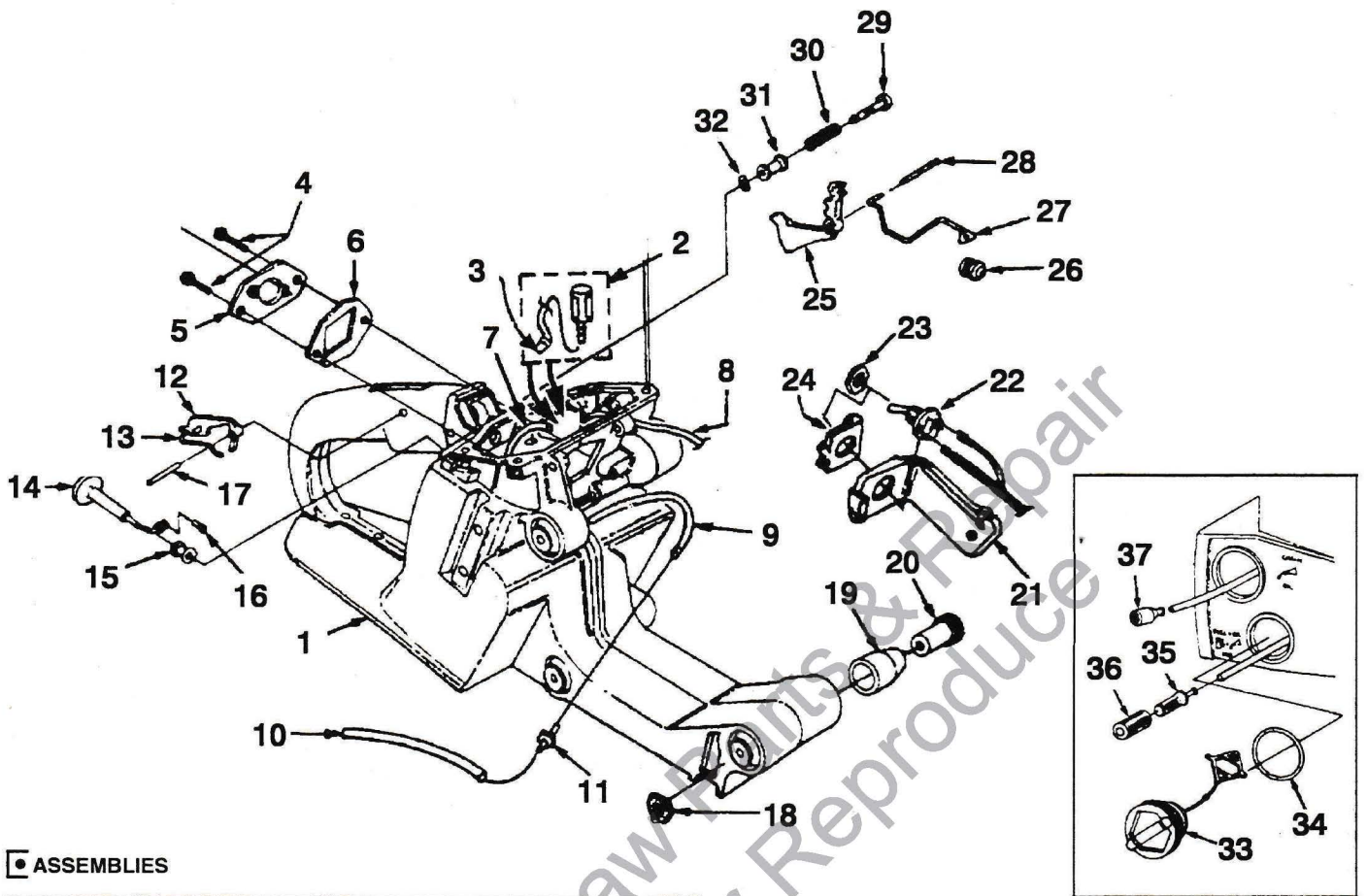

## ASSEMBLIES

NO.	PART NO.	DESCRIPTION	QTY.
1	A 04892 A	HOUSING-Engine	1
2	A 07012	TANK VENT KIT	2
3	96841	VALVE-Duck Bill	1
4	96620	SCREW-Torx Truss (10-24 X 1/2")	2
5	97290 2A	ADAPTOR-Carburetor	1
6	97291	GASKET-Carburetor	1
7	93112 38	TUBING-Rubber (Fuel Line, 9 1/2")	1
8	93157 20	TUBING-Rubber (Oil Line, 5")	1
9	93112 26	TUBING-Rubber (Pulse Line, 6 1/2")	1
10	70454 23	TUBING-Rubber (5 3/4")	1
11	02067	FITTING-Inline Fuel	1
12	93385 A	TRIGGER-Lock	1
13	97265	SPRING-Flat	1
14	97292 1	ROD-Choke	1
15	64862	GROMMET	1
16	86324	PIN-Cotter	1
17	68548	PIN-Trigger	1
18	81206	Nut-Locking Hex (10-32)	3
19	97305 2	ISOLATOR-Vibration	6
20	97262	SLEEVE-Flanged	6
21	97306 A	COVER	1
22	A 57650 A	SWITCH-Toggle	1
23	72084 A1	NUT-Hex	1
24	12893	PLATE-Indicating	1
25	93842	TRIGGER-Throttle	1
26	69889	BOOT-Throttle Rod	1
27	97294 A	ROD-Throttle	1
28	68548	PIN-Trigger	1
29	95671	PIN-Throttle Lock	1
30	95020	SPRING-Compression	1
31	95989	BUSHING-Flanged	1
32	58409	RING-Retaining	1
33	A-03131	CAP-Fuel & Oil	2
34	98805-A	GASKET-Fuel & Oil Cap	1
35	A-97700	FILTER-Fuel	1
36	59253-1A	ELEMENT-Felt Filter	1
37	A-68593	OIL FILTER	1

Torque Specs			
Item No	In/Lbs	Nm	Required Locktite
4	50-60	5.6-6.8	262 Red

NOTE: TORQUE SPECIFICATIONS ON PAGE 7.

# CARBURETOR - AIR CLEANER

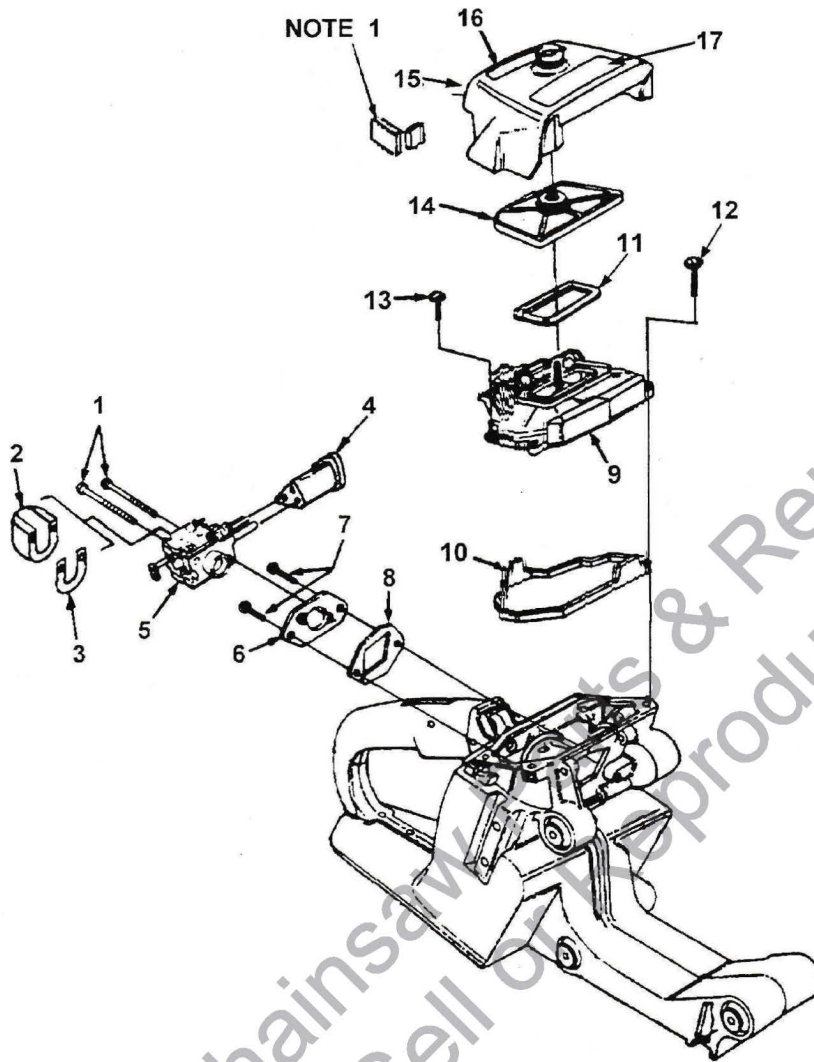

## ASSEMBLIES

NO.	PART NO.	DESCRIPTION	QTY.
1	82527	SCREW-Hex Cap (10-24 X 2")	2
2	49673	SHIELD-Carburetor	1
3	49671	GASKET-Carburetor Shield	1
4	97295	GROMMET	2
5	A 07571	CARBURETOR KIT	1
6	97290 2A	ADAPTER-Carburetor	1
7	96620	SCREW-Torx Truss (10-24 X 1/2")	2
8	97291	GASKET-Carburetor	1
9	A 97296	COVER-Carburetor Chamber	1
10	97298	GASKET-Carburetor Chamber	1
11	04635	GASKET-Air Filter	1
12	80582	SCREW-Pan Hd. (8-32 X 5/8")	2
13	80577	SCREW-Machine Pan Hd. (8-32 x 3/8")	2
14	A 97303 B	ELEMENT-Filter	1
15	A 04636 A	COVER-Air Filter	1
16	00780	DECAL-Warning	1
17	96731 A	DECAL-Warning	1

Torque Specs			
Item No	In/Lbs	Nm	Required Locktite
1	40-50	4.5-5.6	262 Red
7	50-60	5.6-6.8	262 Red
12	15-20	1.7-2.8	242 Blue
13	15-20	1.7-2.8	

NOTE 1: A-03611-A FOAM KIT

# CHAIN BRAKE - HANDLES

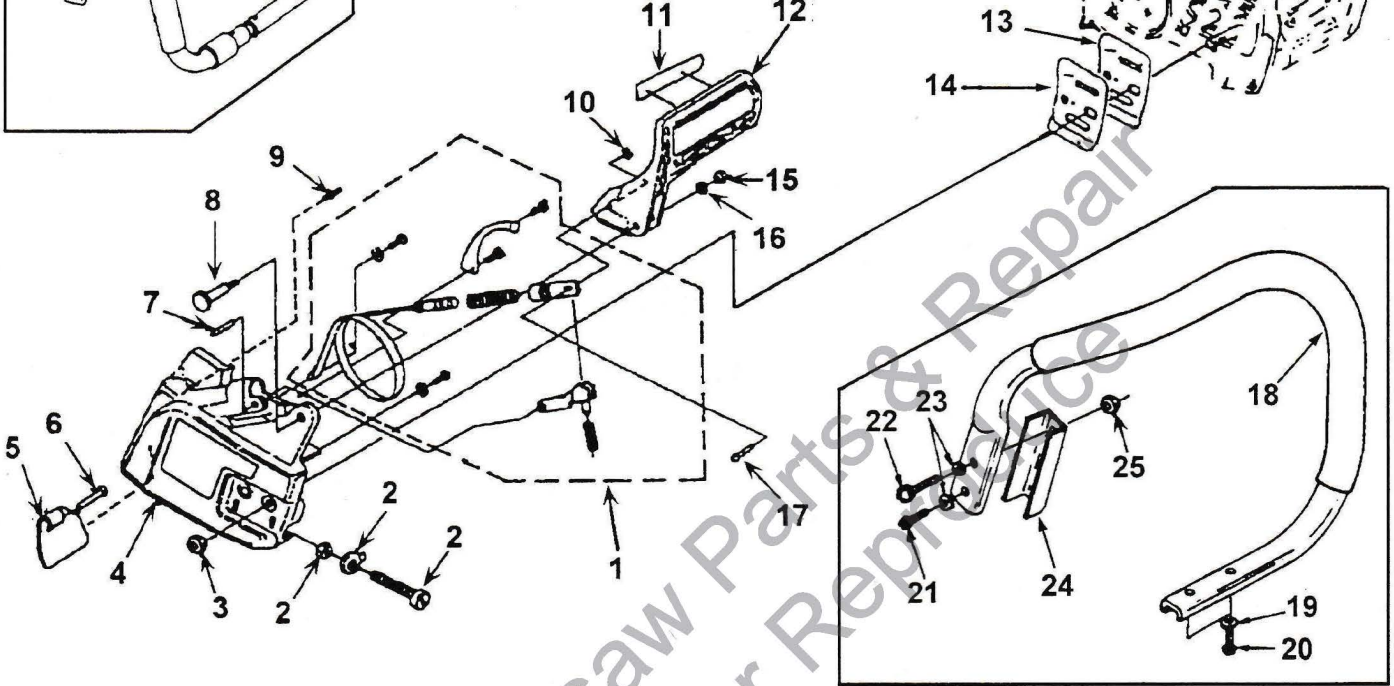
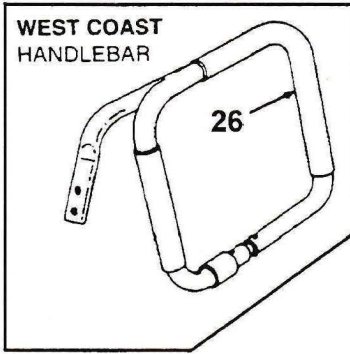

## ASSEMBLIES

NO.	PART NO.	DESCRIPTION	QTY.
1	A 04888	BRAKE BAND ASSY	1
2	A 04889	GUIDE BAR ADJ. KIT	1
3	81089 2	NUT - HEX (10-24)	2
4	A 98727 C	COVER - DRIVE CASE	1
5	04634	SAWDUST SHIELD	1
6	85154	RIVET - PAN HD (.187 X .381)	1
7	98456	PIN (5M X 16MM)	1
8	98461	SCREW - SHOULDER (M5)	1
9	97331	PIN - SHOULDER DOWEL	1
10	01820	RING - SNAP	1
11	02661	DECAL - HANDGUARD	1
12	98740	HANDGUARD	1
13	70399	PLATE - G/BAR (INNER)	1
14	70400	PLATE - G/BAR (OUTER)	1
15	98457	NUT (5MM)	1
16	83203	WASHER - BELLEVILLE (12MM)	1
17	98422 A	PIN - (.156 DIA)	1
18	A 04623	HANDLE BAR (Flush Cut)	1
19	12021	WASHER- Conical (#10)	2
20	80345	SCREW-Socket Cap (10-32 X 5/8")	2
21	82283	SCREW-Socket Cap (10-24 X 3/4")	2
22	82169	SCREW-Socket Cap (10-32 X 7/8")	1
23	12021	WASHER- Conical (#10)	2
24	A 07435	NEST KIT- (Includes 24, 51, 54, 55 & 56)	1
25	81206	NUT-Lock (#10)	1
26	A 04624	HANDLE BAR (West Coast)	1

Item No	Torque Specs		Required Locktite
	In/Lbs	Nm	
3	Hand Tight		
8	40-50	4.5-5.6	
15	40-50	4.5-5.6	
20	70-80	7.9-9.0	262 Red
21	80-90	9.0-10.2	262 Red
22	80-90	9.0-10.2	262 Red

**CUSTOMER ASSISTANCE**

FOR THE LOCATION OF YOUR  
NEAREST HOMELITE SERVICING  
DEALER IN THE UNITED STATES,  
PUERTO RICO, AND  
THE VIRGIN ISLANDS,

**CALL:**

**1-800-242-4672**

**HEADQUARTERS**

Homelite, Inc.  
P.O. BOX 7047  
CHARLOTTE, N.C. 28241

**OVERSEAS OFFICES**

**EUROPE, AFRICA & MIDDLE-EAST**

Homelite Netherlands B.V.  
A Deere & Company Affiliate  
Haverstraat 24  
2153 GB Nieuw Vennepe  
The Netherlands

**FRANCE**

Homelite Atlantic SARL  
Groupe Deere & Co.  
BP 7011  
95050 Cergy Pontoise Cedex  
France

**AUSTRALIA**

Homelite Pacific Ltd.  
A Deere & Company Affiliate  
ACN 008 683 538  
94 Rushdale Street  
P.O. Box 555 MDA  
Australia

**CANADIAN OFFICES**

Homelite Canada Limited  
Homelite Canada Limitée

A Deere & Company Affiliate/  
Une Filiale de Deere & Company  
1850-55e/th Avenue  
Lachine, Québec, Canada H8T 3J5  
1-800-363-5715

UNIT 212-214, 590 Ebury Place  
New Westminster, B.C. V3M 6K7  
1-800-667-3128

20-D Voyager Court South  
Etobicoke, Ontario M9W 5M7  
1-800-465-2249

**Homelite**.inc.  
A Subsidiary of Deere & Company