

parts list

650

automatic chain saws

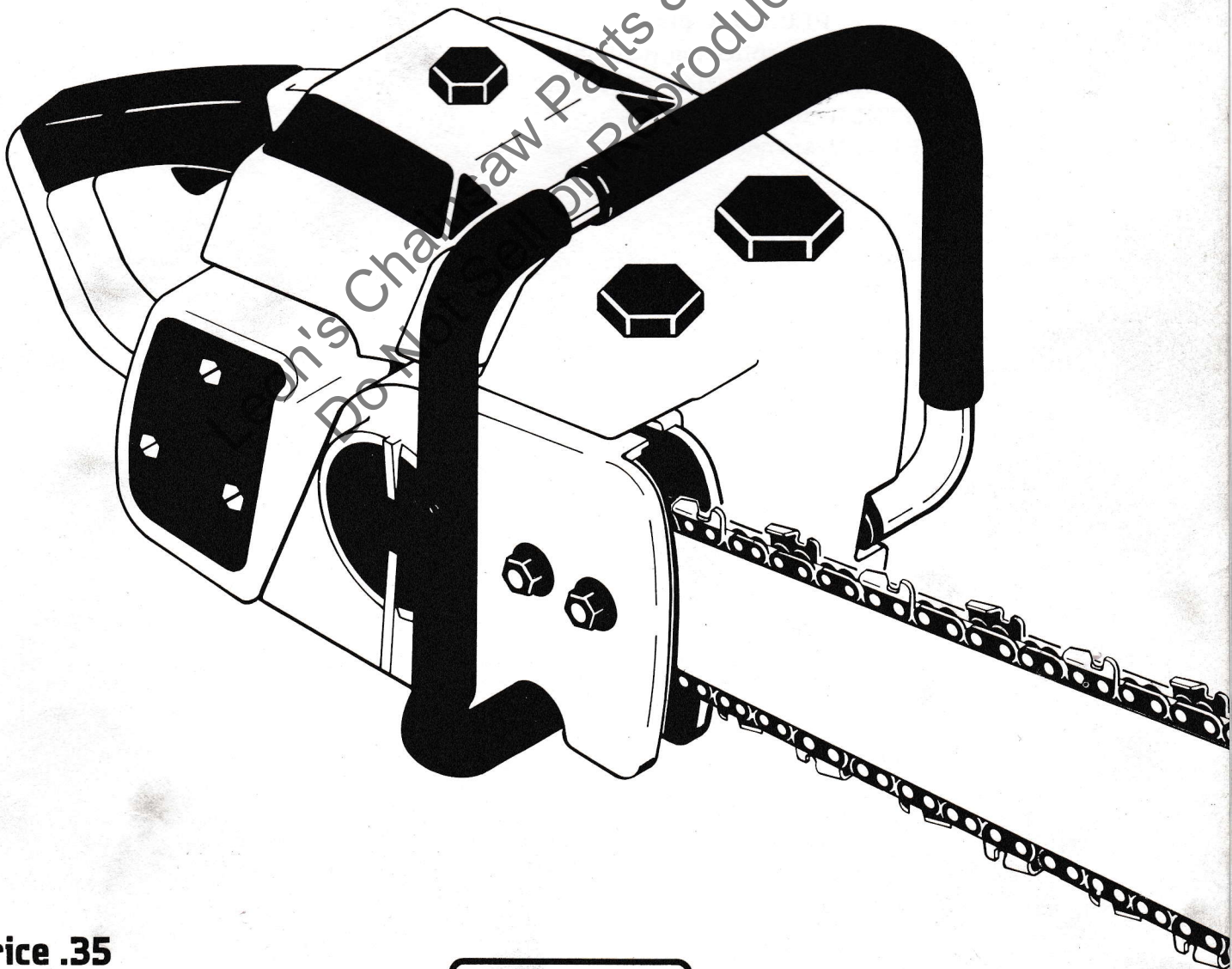

price .35

part no. 24836

HOMELITE®

TOOLS

ANVIL-bearing removal (crankcase)	23846-1
ANVIL-bearing removal (crankcase & backplate)	23846-2
*COLLAR & PLUNGER	A-24876
KEY-hex socket	22126
PLIERS-retaining ring	22828
*PLUG-bearing & seal installation & removal	24827-A
*PLUG-seal installation	24826-A
*PULLER-rotor removal	A-24851
*REAMER-valve seat	A-24884
SHIM-black plastic .0125	24306
SLEEVE-seal assembly (crankcase & backplate)	23759
SLEEVE-seal removal (crankcase)	23136-6
TOOL & PLUNGER-piston pin	A-24871
WRENCH-combination (650)only	A-24284
WRENCH-combination (650E)only	A-23937-B
WRENCH-socket (650)only	68651
WRENCH-spanner	A-23696-A

PAINT

SPRAY CAN-black	22772
SPRAY CAN-red	23475

Refer to tool sheet #24908 for complete tool information

* Denotes new parts

650 - 650E automatic saws

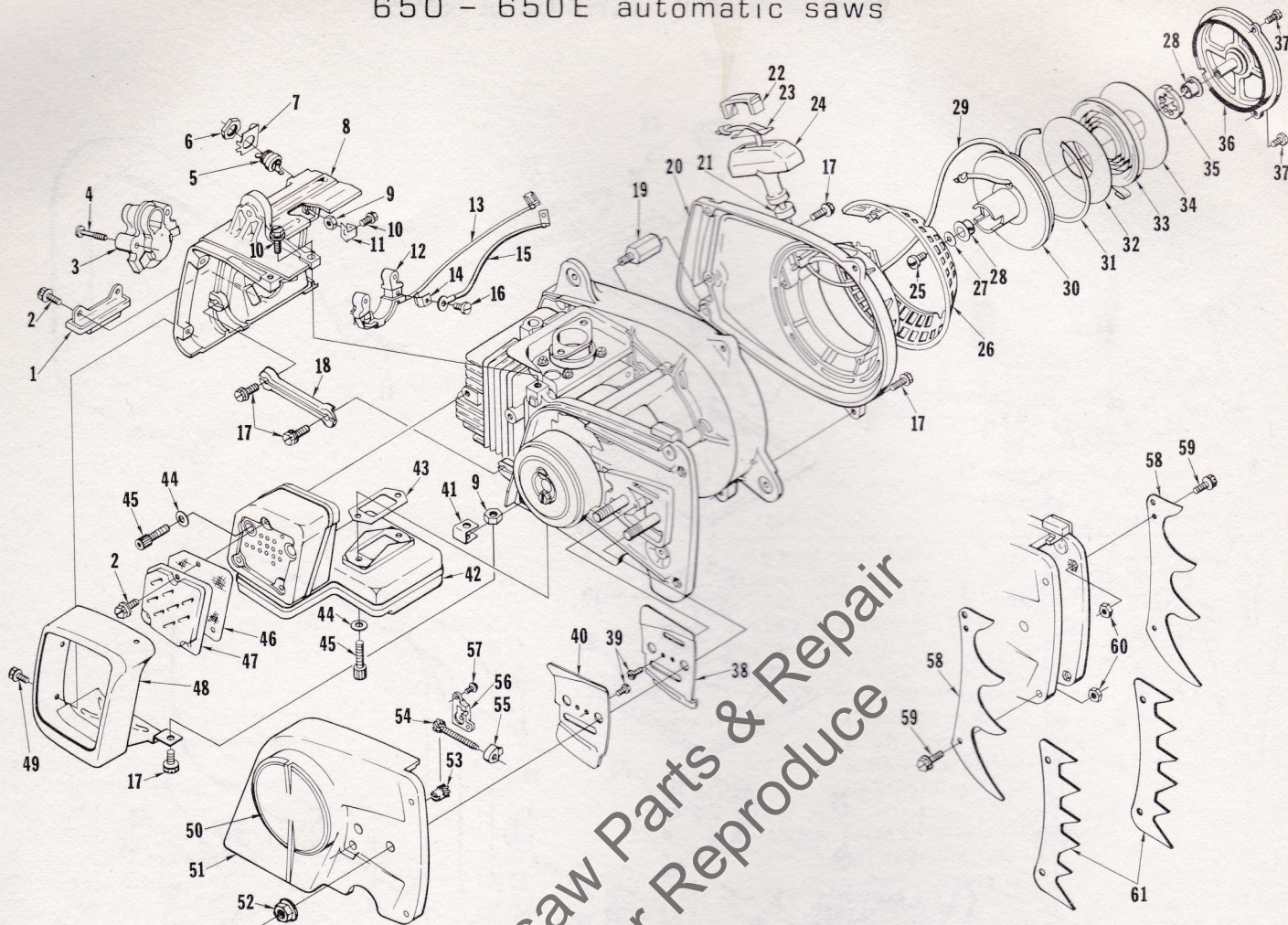

FIGURE 1

No.	Description	Part No.	Qty.	No.	Description	Part No.	Qty.
* 1	SNUBBER-rear	12803	1	*33	SPRING-rewind	12634	1
2	SCREW-hex Sems, 8-32 x 3/8	88026	5	*34	SHIELD-rewind spring (inner)	12635	1
3	TRANSFORMER	12299	2	*35	LOCK-rewind spring	12957	1
4	Includes: SCREW-Plastite GROMMET--shown on Fig. 3	12791-A 12191	2 1	*36	COVER-starter	A-12614-2	1
5	SWITCH-grounding	A-57716	1	*37	SCREW-pan hd., 8-32 x 1/2	82254	3
6	Includes: NUT-hex	72084-A1	1	38	PLATE-guide bar (inner)	67160-A	1
7	PLATE-indicating (ON-OFF)	12793-A	1	39	SCREW-truss hd. 6-32 x 3/8	80548	2
* 8	SHIELD-cylinder	12606-2	1	*40	PLATE-guide bar (outer)	67161-A	1
9	NUT-hex, 10-24	81208	3	*41	RETAINER-nut	12689	1
10	SCREW-hex Sems, 10-24 x 3/4	88022	3	*42	MUFFLER	A-12815	1
*11	RETAINER-nut	12672	2	*43	Includes: GASKET	12826	1
12	RECEPTACLE-transformer	12629	1	*44	WASHER	12940	4
*13	LEAD-module	A-12719	1	*45	SCREW-soc. hd., 10-24 x 3/4	82283	4
14	CONTACT-transformer	12788	2	*46	ARRESTOR-spark	12825	1
*15	LEAD-ground	A-12718	1	*47	CAP-muffler exhaust	12824-1	1
16	SCREW-pan hd. Plastite, # 6 x 3/8	82215	2	*48	SHIELD-muffler	12941-2	1
17	SCREW-hex Sems, 10-24 x 5/8	88020	8	49	SCREW-hex Sems, 10-24 x 1/2	88024	3
*18	BRACE-cylinder shield	12773	1	*50	DECAL-650	12827	2
*19	SPACER	A-12935	1	*51	COVER-drivecase	12612-2	1
*20	HOUSING-rewind starter	A-12812	1	*52	NUT-hex, 3/8-16	12860	2
21	Includes: BUSHING-starter rope	67177	1	*53	ADJUSTER-guide bar	A-12716	1
22	CAP-rope grip	12782	1	*54	SCREW-guide bar adjustment	A-12746	1
23	INSERT-rope retaining	12649	1	55	PIN-guide bar adjustment	67586-1A	1
24	GRIP-starter rope	12624	1	56	COVER-gear	12134	1
25	SCREW-pan hd., 10-24 x 1/2	82216	1	57	SCREW-pan hd., 6-32 x 3/8	82251	2
26	SCREEN-starter housing	12625	1	58	PLATE-bumper (650 only)	69275	2
*27	WASHER-retaining	12789	1	59	SCREW-hex Sems, 10-24 x 1/2	88024	4
*28	BUSHING-starter post	12639	2	60	NUT-hex, 10-24	81208	4
*29	ROPE-starter, 38"	12946	1	*61	PLATE-bumper (650E only)	A-24889	2
*30	PULLEY-starter	A-12615-1	1		Includes: SCREW-hex Sems, 10-24 x 1/2 NUT-hex, 10-24	88024 81208	4 4
*31	RING-retaining	12637	1				
*32	SHIELD-rewind spring (outer)	12636	1				

* Denotes new parts

650 - 650E automatic saws

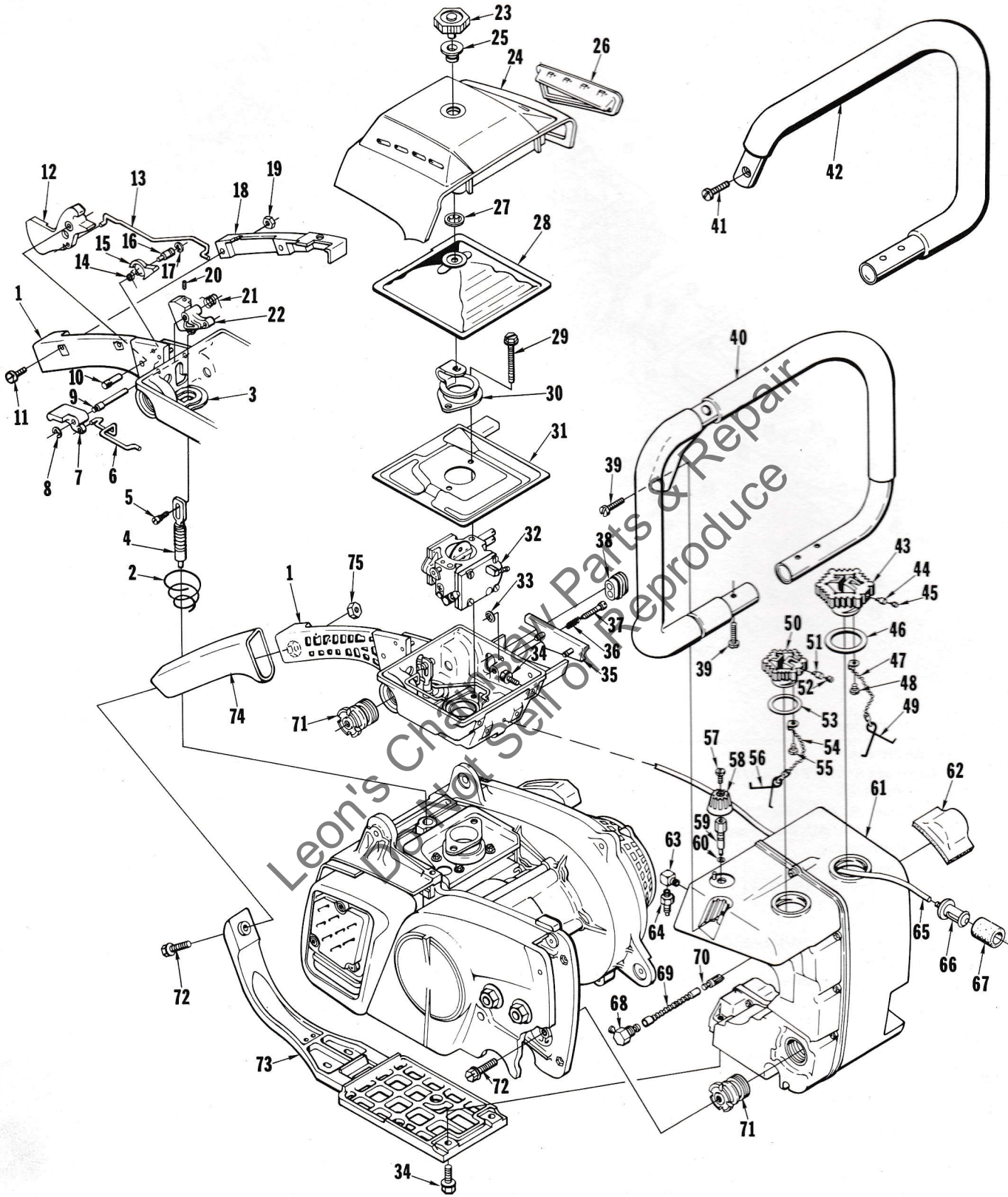

FIGURE 2

650 - 650E automatic saws

No.	Description	Part No.	Qty.	No.	Description	Part No.	Qty.
* 1	HANDLE-throttle	A-12813	1	*39	SCREW-fil. hd., 10-24 x 7/8 (650)	82257	4
* 2	Includes: SPRING-compression	12867	1	*40	HANDLE BAR-wrap around (650)	A-12714	1
* 3	BOOT-sealing	12799	1	*41	SCREW-fil. hd., 10-24 x 7/8 (650E)	82257	3
* 4	VALVE-compression release	A-12712	1	*42	HANDLE BAR-flush cut (650E)	A-12898	1
* 5	SCREW-shoulder	12861	1	43	CAP-fuel filter	A-69500	1
* 6	ROD-choke	12643	1	44	Includes: VALVE-check (oval duckbill)	69451	1
* 7	LEVER-choke	12620	1	45	FILTER-filler cap	69454	1
* 8	RING-retainer	69071	1	46	GASKET-fuel cap	69501	1
* 9	PIN-pivot (compression arm)	12682	1	47	CHAIN-bead	69502	1
10	PIN-trigger	68548	1	48	SCREW-pan Plastite #6 x 1/4	82256	1
*11	SCREW-pan hd., 8-32 x 3/8	82253	2	49	RETAINER	69503	1
*12	TRIGGER-throttle	12618	1	50	CAP-oil filler	A-12222	1
*13	ROD-throttle	12642	1	51	Includes: VALVE-check (oval duckbill)	69451	1
*14	SPRING-torsion (compression cam)	12681	1	52	FILTER-filler cap	69454	1
*15	CAM-compression release	12621	1	53	GASKET-oil cap	12126	1
*16	PIN-pivot (compression cam)	12680	1	54	CHAIN-bead	69502	1
*17	RING-retaining	12683	1	55	SCREW-pan Plastite #6 x 1/4	82256	1
*18	COVER-throttle handle	12616-2	1	56	RETAINER	69503	1
19	NUT-hex, 8-32	81223	2	*57	SCREW-pan hd., 8-32 x 3/8	82253	1
*20	SCREW-set, 10-32 x 3/8	12864	1	*58	KNOB-oil regulation	12771	1
*21	SPRING-torsion	12656	1	*59	VALVE-oil regulation	A-12726	1
*22	ARM-compression release valve	12644-1	1	60	Includes: "O" RING	59074	1
*23	NUT-filter cover mounting	A-12712-1	1	*61	TANK-fuel	A-12814	1
*24	COVER-air filter	A-12816	1	*62	Includes: BUMPER-fuel tank	12863	1
25	Includes: BUSHING	12110	1	63	CONNECTOR-elbow, 90°	31734	1
*26	INTAKE-air (air filter cover)	12893	1	64	FITTING-straight	68393	1
27	NUT-push-on spring	12140	1	*65	LINE-fuel	A-68053-A	1
*28	FILTER ELEMENT-air	A-12742-A	1	66	PICK-UP-fuel	A-59251	1
*29	SCREW-hex Sems, 10-24 x 2	88028	2	67	Includes: FILTER-felt	59253-1	1
*30	TUBE-air intake	A-12704	1	*68	ELBOW-90° oil line	12661	1
*31	SHIELD-carburetor chamber	12889	1	69	LINE-oil	63605	1
*32	CARBURETOR	A-12717	1	70	FINDER-oil	A-65172	1
*33	NUT-push-on	12903	2	*71	ISOLATOR-vibration	A-12708-B	4
34	SCREW-hex Sems, 10-24 x 5/8	88020	6	72	SCREW-hex Sems, 10-24 x 3/4	88022	5
*35	DEFLECTOR-air	12894	1	*73	BRACE-throttle handle	12610-2A	1
*36	SPRING-idle adjustment	12784	1	*74	GRIP-throttle handle	12675	1
*37	SCREW-idler adjustment	12783	1	75	NUT-hex, 10-24	81208	1
*38	GROMMET-carburetor needle	12891	1				

* Denotes new parts

650 - 650E automatic saws

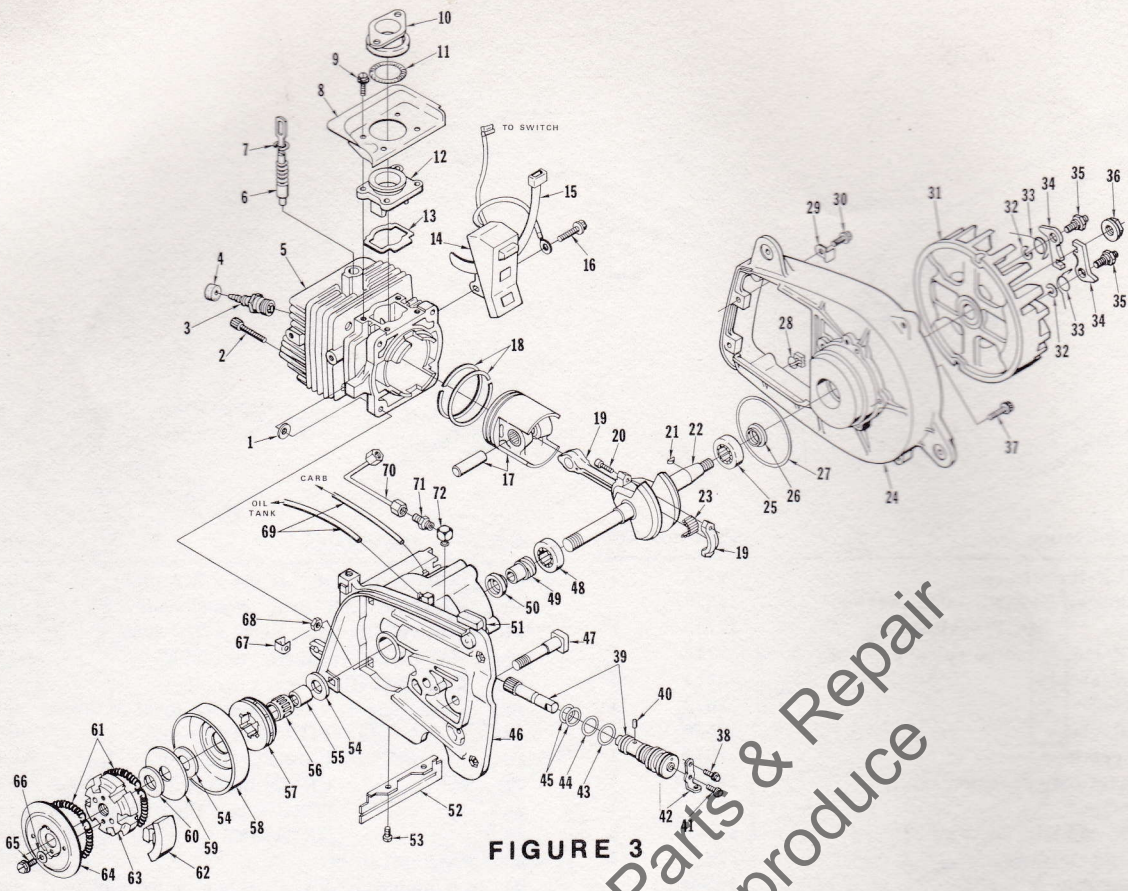

FIGURE 3

No.	Description	Part No.	Qty.	No.	Description	Part No.	Qty.
* 1	WASHER-conical	12631	4	*39	PUMP-automatic oil	A-12723	1
* 2	SCREW-socket hd., 10-24 x 1	82246	4	*40	Includes: PIN-cam guide	12108	1
* 3	SPARK PLUG-(UCJ-4G)	68713-S	1	*41	SCREW-hex Sems, 8-32 x 3/8	88026	1
	SPARK PLUG-"J" gap type (accessory)	69027-S	1	*42	BRACKET-oil pump retainer	12076	1
4	GROMMET-spark plug	12191	1	*43	"O" RING	12854	1
* 5	CYLINDER	A-12728	1	*44	"O" RING	12095	1
* 6	Includes: VALVE-compression release	A-12712	1	*45	"O" RING	12853	2
7	RING-retaining	75130	1	*46	CRANKCASE	A-12721	1
* 8	DEFLECTOR-air	12794	1	47	Includes: STUD-guide bar	58334	2
* 9	SCREW-hex Sems, 8-32 x 5/8	88026	4	48	BEARING-roller	63195	1
*10	CONNECTOR-carburetor	12623	1	49	GEAR-worm	12071	1
*11	SPRING-garter	12856	1	50	SEAL	12282	1
*12	MANIFOLD-intake	12622	1	*51	BUMPER-crankcase	12755	1
*13	GASKET-intake manifold	12648	1	*52	SHIELD-heat	12777	1
14	MODULE & CORE	12669	1	53	SCREW-pan hd., 8-32 x 3/8	82253	2
15	TIE-cable (module leads)	12298	1	*54	WASHER-thrust	12668	2
16	SCREW-hex Sems, 8-32 x 1-1/4	82194	2	*55	RACE-inner (650)	12882	1
*17	PISTON & PIN	A-12811	1	56	BEARING-needle (unit cage) 650	64124	1
*18	Includes: PISTON RING	12659	2	57	SPROCKET-rim (7 tooth .404 pitch) 650	63285	1
*19	ROD-connecting	A-12700-A	1	58	HUB & DRUM- 7 spline (650)	A-68727	1
20	Includes: SCREW-socket, 10-32 x 5/8	80345	2				
21	KEY-woodruff	75078	1	*55	RACE-inner (650E)	12666	1
*22	CRANKSHAFT	12605-1	1	56	BEARING-needle (unit cage) 650E	65393	1
*23	ROLLERS-needle (set of 24)	A-12702	1	57	SPROCKET-rim (8 tooth .404 pitch) 650E	65960	1
*24	PLATE-back	A-12728	1	58	HUB & DRUM-6 spline (650E)	A-65991	1
25	Includes: BEARING-roller	63195	1	* 58	† SPROCKET & DRUM-spur (8T, 3/8 pitch) A-12819	12819	1
26	SEAL	12282	1	*59	WASHER-thrust	12907	1
27	"O" RING	67559	1	*60	WASHER-thrust	12667	1
*28	RETAINER-lead	12859	1	61	SPRING-clutch	67441	2
*29	CLIP-wire (switch lead retainer)	12896	1	*62	SHOE-clutch	69817-1	6
30	SCREW-hex Sems, 10-24 x 3/4	88022	1	*63	SPIDER-clutch	65723-3	1
*31	ROTOR-magneto	12640	1	*64	COVER-clutch	12772	1
32	WASHER-lock	83056	2	65	SCREW-hex hd., 10-24 x 1/2	80361-1	2
33	SPRING-starter pawl	65375	2	*66	WASHER	12940	2
34	PAWL-starter	58756	2	*67	RETAINER-nut	12689	4
35	STUD-starter pawl	63877-B	2	68	NUT-hex, 10-24	81208	4
*36	NUT-hex flange	81236	1	*69	LINE-flexible	12693	2
37	SCREW-hex Sems, 10-24 x 5/8	88020	5	*70	LINE-oil	A-12817	1
38	SCREW-hex Sems, 8-32 x 3/8	88026	1	71	VALVE-check	A-65077	1
				72	CONNECTOR-elbow 90°	31734	1

* Denotes new parts † Denotes accessory

ALWAYS FURNISH MODEL AND SERIAL NUMBER WHEN ORDERING PARTS.

650 - 650E automatic saws

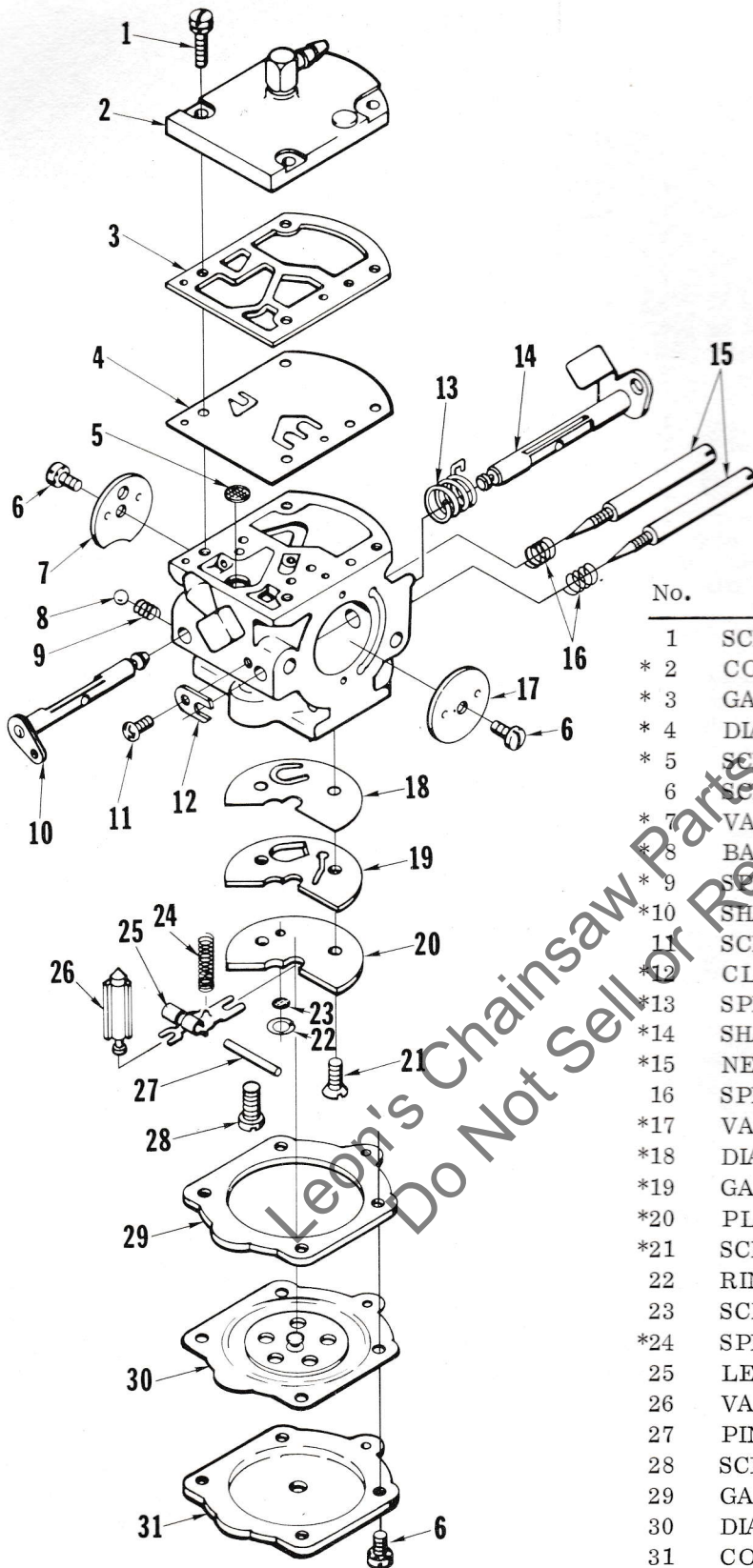

A-12717 WB-2

No.	Description	Part No.	Qty.
1	SCREW-pump cover	64694	4
* 2	COVER-fuel pump	12829	1
* 3	GASKET-pump	‡12836	1
* 4	DIAPHRAGM-pump	†12839	1
* 5	SCREEN-inlet	†12844	1
6	SCREW	64689	6
* 7	VALVE-choke	12833	1
* 8	BALL-choke friction	†12834	1
* 9	SPRING-choke friction	†12841	1
* 10	SHAFT-choke	12832	1
11	SCREW-clip	†64693	1
* 12	CLIP-throttle shaft	†12880	1
* 13	SPRING-throttle return	†12842	1
* 14	SHAFT-throttle	12830	1
* 15	NEEDLE-adjustment	†12843	2
16	SPRING-needle adjustment	†64236	2
* 17	VALVE-throttle	12831	1
* 18	DIAPHRAGM-circuit check valve	12838	1
* 19	GASKET-circuit	‡12835	1
* 20	PLATE-circuit	12845	1
* 21	SCREW-circuit plate	12840	2
22	RING-screw retaining	67360	1
23	SCREEN-check valve	67381	1
* 24	SPRING-metering lever	†12879	1
25	LEVER-metering	†64245	1
26	VALVE-inlet needle	†64229	1
27	PIN-metering lever	†64244	1
28	SCREW-metering lever pin	†64688	1
29	GASKET-metering diaphragm	‡64231	1
30	DIAPHRAGM-metering	†64235	1
31	COVER-metering diaphragm	64224	1
* 32	GASKET-set	†12837	1
* 33	REPAIR KIT	12846	1

* Denotes new parts

† Indicates contents of Repair Kit 12846

‡ Indicates contents of Gasket Set 12837

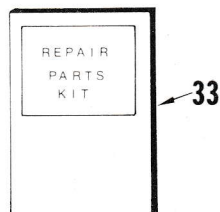
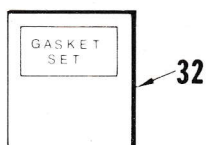

650 - 650E automatic saws

Part No.	Description	Qty.	Part No.	Description	Qty.	Part No.	Description	Qty.	Part No.	Description	Qty.
12071	Gear-worm	1	*A-12704	Tube-air intake	1	*12854	"O" Ring	1	64689	Screw	6
*12076	Bracket-oil pump	1	*A-12708-B	Isolator-vibration	4	*12858	Spring-garter	1	64693	Screw-clip	1
12095	"O" Ring	1	*12712	Valve	1	*12859	Retainer-lead	1	64694	Screw-pump	4
*12108	Pin-cam guide	1	*A-12714	Handle Bar	1	*12861	Screw-shoulder	1	A-65077	Valve-check	1
12110	Bushing	1	*A-12716	Adjuster-guide	1	*12863	Bumper-fuel	1	A-65172	Finder-oil	1
*A-12112-1	Nut-filter	1	*A-12717	Carburetor	1	*12867	Spring	1	65375	Spring-starter	2
12126	Gasket-oil cap	1	*A-12718	Lead-ground	1	*12876	Spring-helical	1	65393	Bearing-needle	1
12134	Cover-gear	1	*A-12719	Lead-module	1	*12879	Spring-lever	1	*65723-3	Spider-clutch	1
12140	Nut-push-on spring	1	*A-12721	Crankcase	1	*12880	Clip-throttle	1	65960	Sprocket-rim	1
12191	Grommet	2	*A-12723	Pump-automatic	1	*12882	Race-inner	1	A-65991	Hub & Drum	1
A-12222	Cap-oil filler	1	*A-12726	Valve-oil	1	*12889	Shield-carburetor	1	67160-A	Plate-guide bar	1
12282	Seal	2	*A-12728	Back-plate	1	*12891	Grommet	1	67177	Bushing-ropo	1
12298	Tie-cable	1	*A-12729	Cylinder	1	*12893	Intake-air	1	67360	Ring-screen	1
A-12299	Transformer	1	*A-12742-A	Filter Element	1	*12894	Deflector-air	1	67381	Screen-check	1
*12605-1	Crankshaft	1	*A-12746	Screw-guide bar	1	*12896	Clip-wire	1	67441	Spring-clutch	2
*12606-2	Shield-cylinder	1	*12755	Bumper	1	*A-12898	Handle Bar	1	67559	"O" Ring	1
*12610-2A	Brace-throttle	1	*12771	Knob-oil	1	*12903	Nut-push on	2	67586-1A	Pin-guide bar	1
*12612-2	Cover-drivecase	1	*12772	Cover-clutch	1	*12907	Washer-thrust	1	*A-68053-A	Line-fuel	1
*A-12614-2	Cover-starter	1	*12773	Brace-cylinder	1	*A-12935	Spacer	1	*68173-S	Spark Plug	1
*A-12615-1	Pulley-starter	1	*12777	Shield-heat	1	*12940	Washer	6	68393	Fitting-straight	1
*12616-2	Cover-throttle	1	12782	Cap-rope grip	1	*12941-2	Shield	1	68548	Pin-trigger	1
*12618	Trigger-throttle	1	*12783	Screw-idle	1	*12946	Rope-starter	1	68651	Wrench-socket	1
*12620	Lever-choke	1	*12784	Spring-idle	1	22126	Key-hex socket	1	A-68727	Hub & Drum	1
*12621	Cam-compression	1	12788	Contact	2	22772	Paint-blade	1	69027-S	Spark Plug	1
*12622	Manifold-intake	1	*12789	Washer-retaining	1	22828	Pliers-retaining	1	*69071	Ring-retainer	1
*12623	Connector	1	12791-A	Screw-Plastite	2	23136-6	Sleeve-seal	2	69275	Plate-bumper	2
12624	Grip-starter rope	1	12793-A	Plate-indicating	1	23475	Paint-red	1	69451	Valve-check	2
12625	Screen-starter	1	*12794	Deflector-air	1	A-23696-A	Wrench-spanner	1	69454	Filter-filler cap	2
12629	Receptacle	1	*12799	Boot-sealing	1	23759	Sleeve-seal	1	A-69500	Cap-fuel filler	1
*12631	Washer-conical	4	*A-12803	Snubber-rear	1	23846-1	Anvil-bearing	1	69501	Gasket-fuel cap	1
*12634	Spring-rewind	1	*A-12811	Piston & Pin	1	23846-2	Anvil-bearing	1	69502	Chain-bead	2
*12635	Shield-rewind	1	*A-12812	Housing-rewind	1	A-23937-B	Wrench	1	69503	Retainer	2
*12636	Shield-rewind	1	*A-12813	Handle-throttle	1	A-24284	Wrench	1	*69817-1	Shoe-clutch	6
*12637	Ring-retaining	1	*A-12814	Tank-fuel	1	24300	Shim-black	1	72084-A1	Nut-hex	1
*12639	Bushing-starter	2	*A-12815	Muffler	1	*24826-A	Plug-seal	1	75078	Key-Woodruff	1
*12640	Rotor-magneto	1	*A-12816	Cover-air filter	1	*24827-A	Plug-bearing	1	75120	Ring-retaining	1
*12642	Rod-throttle	1	*A-12817	Line-oil	1	*A-24851	Puller-rotor	1	FASTENING PARTS		
*12643	Rod-choke	1	*A-12819	Sprocket & Drum	1	A-24871	Tool & Plunger	1	*12860	Nut-3/8-16	2
*12644-1	Arm-compression	1	*12824-1	Cap-muffler	1	*A-24876	Collar & Plunger	1	*12864	10-32 x 3/8	1
*12648	Gasket-intake	1	*12825	Arrestor-spark	1	*A-24884	Reamer-valve	1	80345	10-32 x 5/8	2
12649	Insert-rope	1	*12826	Gasket	1	*A-24889	Plate-bumper	2	80361-1	10-32 x 1/2	2
*12656	Spring-torsion	1	*12827	Decal-650	2	31734	Connector	2	80548	6-32 x 3/8	2
*12659	Piston Ring	2	*12829	Cover-fuel	1	A-57716	Switch-grounding	1	81208	Nut-10-24	15
*12661	Elbow-oil line	1	*12830	Shaft-throttle	1	58334	Stud-guide bar	2	81223	Nut-8-32	2
*12666	Race-inner	1	*12831	Valve-throttle	1	58756	Pawl-starter	2	*81236	Nut	1
*12667	Washer-thrust	1	*12832	Shaft-choke	1	59074	"O" Ring	1	82194	8-32 x 1-1/4	2
*12668	Washer-thrust	2	*12833	Valve-choke	1	A-59251	Pick-up-fuel	1	82215	6 x 3/8	2
12669	Module & Core	1	*12834	Ball-choke	1	59253-1	Filter-felt	1	82216	10-24 x 1/2	1
*12672	Retainer-nut	2	*12835	Gasket-circuit	1	63195	Bearing-roller	2	*82246	10-24 x 1	4
*12675	Grip-throttle	1	*12836	Gasket-pump	1	63285	Sprocket-rim	1	82251	6-32 x 3/8	2
*12957	Lock-rewind	1	*12837	Gasket-set	1	63605	Line-oil	1	*82253	8-32 x 3/8	5
*12680	Pin-pivot	1	*12838	Diaphragm	1	63877-B	Stud-starter	2	*82254	8-32 x 1/2	3
*12681	Spring-torsion	1	*12839	Diaphragm	1	64124	Bearing-needle	1	82256	6 x 1/4	2
*12682	Pin-pivot	1	*12840	Screw-circuit	2	64224	Cover-metering	1	*82257	10-24 x 7/8	7
*12683	Ring-retaining	1	*12841	Spring-choke	1	64229	Valve-inlet	1	*82283	10-24 x 3/4	4
*67161-A	Plate-guide bar	1	*12842	Spring-throttle	1	64231	Gasket-metering	1	83056	Washer-lock	2
*12689	Retainer-nut	5	*12843	Needle	2	64235	Diaphragm	1	88020	10-24 x 5/8	19
*12693	Line-flexible	2	*12844	Screen-inlet	1	64236	Spring-needle	2	88022	10-24 x 3/4	9
*A-12700-A	Rod-connecting	1	*12845	Plate-circuit	1	64244	Pin-metering	1	88024	10-24 x 1/2	11
*A-12702	Rollers-needle	1	*12846	Repair Kit	1	64245	Lever-metering	1	88026	8-32 x 3/8	7
			*12853	"O" Ring	2	64688	Screw-metering	1	*88028	10-24 x 2	2
									*88029	8-32 x 5/8	4

* Denotes new parts



A lextron DIVISION

PORT CHESTER, NEW YORK, U.S.A. 10573

PRINTED IN U.S.A.

E1547CJZ