

# OPERATOR'S MANUAL

PERFORMANCE · DEPENDABILITY  
SERVICE

## HOMELITE

### MODEL 5-20 CHAIN SAW



#### AUTHORIZED SALES AND SERVICE

Homelite has 2500 chain saw dealers and 65 factory branches in the United States and Canada ready to serve you with parts and factory trained mechanics. For prompt service see your local Homelite Chain Saw dealer or wire factory for nearest service location.

Bulletin L-353

Thank you for the confidence you have shown in us by your purchase of a Homelite Chain Saw. Your selection of a truly fine chain saw that combines advanced design, construction and performance is a reflection of your sound judgment. It is our earnest hope that the satisfaction you derive from operating your new chain saw will make you more than glad you chose Homelite.

Experience over the years clearly shows that a little care in maintaining a chain saw goes a long way. To help you get the most from your Homelite Chain Saw, we have prepared this manual for satisfied service.

Read this manual carefully before starting operation. Your time will be well repaid in trouble-free service, reduced operating expense and longer chain saw life. When your Homelite does need maintenance attention, see your Homelite dealer.

# HOMELITE CHAIN SAW

## MODEL 5-20

### OPERATOR'S MANUAL

#### TABLE OF CONTENTS

	<i>Page</i>
<b>OPERATION</b> . . . . .	3
1. PREPARING SAW FOR USE . . . . .	3
a. Unpacking . . . . .	3
b. Assembling Straight Blade . . . . .	3
c. Adjusting Straight Blade Chain Tension . . . . .	4
d. Assembling Bow Saw and Chain . . . . .	4
e. Adjusting Bow Saw Chain Tension . . . . .	4
f. Filling Chain Oil Reservoir . . . . .	5
g. Filling Gear Case . . . . .	5
h. Mixing Fuel . . . . .	5
2. STARTING AND STOPPING . . . . .	5
a. Starting . . . . .	5
b. Stopping . . . . .	6
3. OPERATING SAW . . . . .	6
a. Safety Precautions . . . . .	6
b. General . . . . .	7
c. Straight Blade . . . . .	8
d. Plunge Cut Bow Saw . . . . .	10
e. Clearing Attachment . . . . .	11
f. Brush Cutter Attachment . . . . .	12
<b>MAINTENANCE</b> . . . . .	13
4. MAINTENANCE AND ADJUSTMENT . . . . .	13
a. General Maintenance of Chain and Guide Bar . . . . .	13
b. Sprocket . . . . .	13
c. Chain . . . . .	13
d. Guide Bar . . . . .	14
e. Air Filter . . . . .	15
f. Spark Plug . . . . .	15
g. Carburetor . . . . .	16
h. Trouble Shooting List . . . . .	17

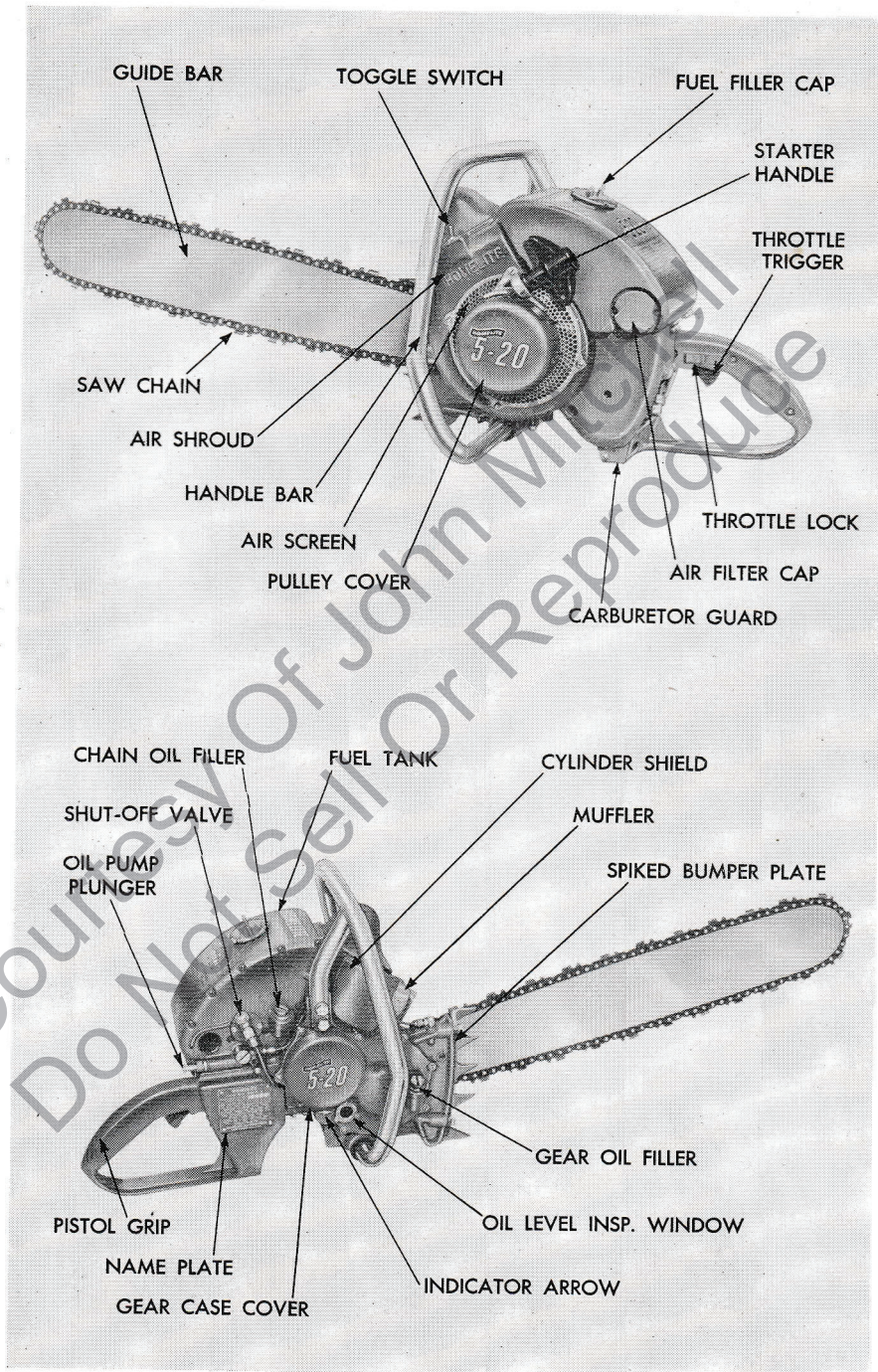

Figure 1—Homelite Model 5-20 Chain Saw

## Section I OPERATION

### 1. PREPARING SAW FOR USE

#### a. Unpacking

(1) The engine gear case has been drained for shipment. The engine carton contains a can of gear oil for filling the gear case, and a combination assembly tool. The chain and guide bar have been packaged separately.

(2) When you mail in your guarantee card, HOMELITE registers the serial number of the saw in your name and the guarantee goes into effect. The serial number is stamped on the name plate (See figure 1, *bottom*) of your unit. When ordering parts, always give both model and serial number of the saw, so there will be no delay in filling your order.

#### b. Assembling Straight Blade (see figure 2)

(1) Remove the two  $\frac{3}{8}$ -16 hex nuts and lockwashers and lift the chain tension device from the mounting studs. Leave the guide bar shim on the studs. Place the guide bar and then the chain tension device on the studs. Slide the guide bar until the tension device pin drops into the hole in the guide bar. Put the lockwashers and nuts back on the studs. Tighten the nuts just enough to hold tension device and guide bar in place.

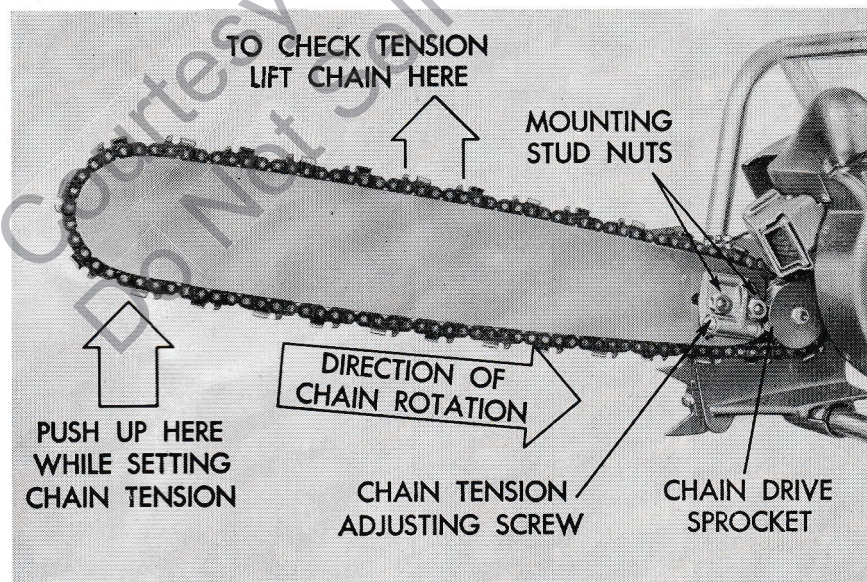

Figure 2—Assembling Guide Bar and Chain

(2) Turn the chain tension adjusting screw counterclockwise as far as it will go without forcing. This will give clearance to assemble chain on the guide bar.

(3) The chain must be assembled on the guide bar so that the cutting edges of the chain teeth will face in the direction of rotation. (See figure 2.) After slipping chain over the drive sprocket, feed chain into the guide bar groove.

#### **c. Adjusting Straight Blade Chain Tension**

(1) Hold up the tip of the guide bar to take up the play between the studs and the mounting slot. The guide bar must be held in this position while the chain tension is adjusted (otherwise the guide bar will shift on the first cut, changing the tension). Improper chain tension causes excessive wear.

(2) Turn the chain tension adjusting screw clockwise to take up most of the chain slack. The tension is correct when the chain can be easily lifted  $\frac{1}{4}$ " from the guide bar groove near the middle of the top edge.

(3) Still holding up the tip of the guide bar, tighten the two hex nuts to lock tension device at proper setting.

(4) New chains always stretch slightly. Check the tension again after making a few cuts with a new chain. Adjust the tension if necessary.

#### **d. Assembling Bow Saw and Chain**

(1) If the unit is being converted from straight blade to bow saw, remove the chain tension device, guide bar and chain from unit. Leave the guide bar shim in place on the gear case studs.

(2) Position chain on bow guide. Be sure chain is installed with the cutting edges rotating toward the bottom of the sprocket. (See figure 2.)

(3) Hold bow attachment and place chain in position on sprocket. Angle bow to clear muffler, and place on mounting studs. Locate adjusting plate on studs and lightly hold in place with two  $\frac{3}{8}$ -16 hex nuts and lockwashers.

#### **e. Adjusting Bow Saw Chain Tension**

(1) Be sure the two hex nuts holding bow attachment are loose, permitting bow to move when adjusting screw is turned.

(2) Hold up the tip of the guide to take up the play between the studs and the bow mounting slot. The bow attachment must be held in this position while the chain is adjusted, or it will shift on the first cut, changing the tension. Improper tension causes excessive wear.

(3) Turn chain tension adjusting screw counterclockwise until the chain can no longer be rotated by hand. Then turn adjusting screw clockwise until chain can be freely rotated by hand.

(4) Still holding up the front of the guide, tighten the two hex nuts to lock the bow in position.

(5) New chains will stretch slightly. Check the tension again after making a few cuts with the saw. Readjust the chain tension if necessary.

#### f. Filling Chain Oil Reservoir

Fill chain oil reservoir, located on the right side of the fuel tank, with SAE-30 engine oil in the summer, and SAE-10 oil in the winter. In temperatures below 0°F, fill the reservoir with a mixture of four parts SAE-10 engine oil to one part of kerosene. Operation of the oil pump plunger forces oil from the reservoir into guide bar groove. When cutting, operate the oil pump at regular intervals.

#### g. Filling Gear Case

THE GEAR CASE HAS BEEN DRAINED FOR SHIPMENT. Fill gear case. Unscrew the oil filler plug located on the gear case cover. With saw standing level, fill gear case with Homelite SAE-90 (Part No. 55291-A) gear oil up to arrow level. DO NOT FILL BEYOND ARROW LEVEL. Too much oil causes the clutch to slip at improper speed. When oil level falls below bottom of window, refill gear case to arrow level only. Replace filler plug.

#### h. Mixing Fuel

##### CAUTION

*Always mix oil and gasoline thoroughly before pouring the fuel into the fuel tank.*

(1) Mix thoroughly  $\frac{3}{4}$  pint of a good grade SAE-30 engine oil with each gallon of gasoline.

(2) A Homelite Safety Can (Part No. AA-71472) provides a convenient way to mix and carry fuel. The safety can has  $2\frac{1}{2}$  gallons capacity. The filler cap serves as an oil measuring cup.

(3) Remove the filler cap and pour one gallon of gasoline into the safety can. Add  $1\frac{1}{2}$  pints of a good grade SAE-30 engine oil. Add one more gallon of gasoline. Replace cap. Shake can well to mix gas and oil thoroughly.

## 2. STARTING AND STOPPING

### a. Starting (see figure 1)

- (1) Push toggle switch to "ON" position.
- (2) Open the fuel shut-off valve all the way (counterclockwise).
- (3) Pull the choke lever, located on the left side of the carburetor, back as far as it will go.
- (4) Depress the throttle trigger in pistol grip. (See figure 1.) Lock throttle open by pulling back throttle lock located on the left side of the pistol grip. Operate oil pump plunger three times to lubricate chain.
- (5) Be sure the chain is clear of all obstructions before pulling the starter,

because the chain will rotate with the wide open throttle; chain will not rotate when throttle is released.

(6) Pull starter cord SLOWLY, a short distance, until you feel the drive balls engage. Then let the cord rewind on the pulley. Keep a slight tension while rewinding the cord so that the starter will remain engaged, NOW pull cord rapidly to crank the engine.

#### NOTE

*Do not let the starter cord snap back after cranking.*

(7) When engine fires (after 3 to 5 spins depending on temperature) return choke to  $\frac{1}{2}$  open position. Leave choke  $\frac{1}{2}$  open until engine starts. As engine warms up, slowly return choke to full open position (away from operator).

(8) To start a hot engine it is not necessary to lock the throttle open. Moreover, a hot engine usually starts without choking.

(9) Depress the throttle trigger to release throttle lock. The pneumatic governor keeps the engine from overspeeding. When the engine idles, the automatic clutch disengages the chain drive. Idle speed control is set to prevent the chain from rotating. This setting has been made at the factory and assures steady idling of the engine.

#### b. Stopping

(1) Push toggle switch on air shroud to "OFF" position; after engine stops, turn switch back on.

#### NOTE

*At the end of each day's operation close the fuel shut-off valve.*

(2) If you are not going to use the saw for a month or more, remove fuel cap, turn saw upside down and drain fuel tank as much as possible. Open shut-off valve and start engine. Let engine run until it stops. This uses up all the fuel remaining in the tank, carburetor and fuel line. This will prevent the fuel tank and carburetor from plugging up with gum and varnish.

### 3. OPERATING SAW

#### a. Safety Precautions

(1) Your chances of staying alive in the woods will be improved if you take adequate precautions whenever a chain saw is used.

(2) Wear protective clothing. When felling, always wear a safety helmet (hard hat) to protect your head from falling branches (widow makers). Always wear heavy, protective, non-slip footwear. Never wear loose-fitting gloves, ties or shirts when operating a chain saw.

(3) Before making a cut, clear the cutting area of limbs and debris which might interfere with your control of the saw. The saw will kick back if either top or



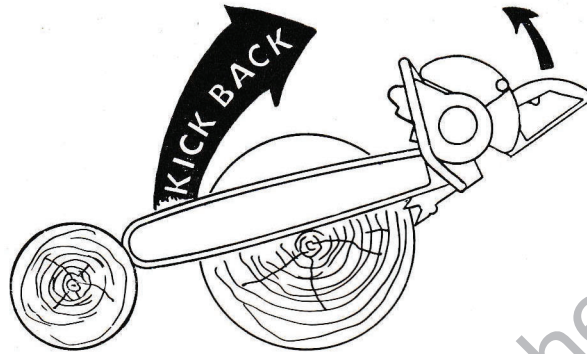

Figure 3—Avoid Hitting Other Branches With Blade

end of the saw blade is allowed to contact other branches. (See figure 3.)

(4) Select a safe position to which you can retreat when the tree is falling. Clear all brush and obstructions from this path of retreat. Observers should remain a safe distance from all sawing operations.

(5) Be sure of your balance at all times. When starting a cut, always place the spikes against the wood before engaging the chain. Otherwise, you may lose your balance as the chain jerks the saw toward the log.

(6) Always stand on the uphill side when bucking a log.

(7) Never carry a running saw — stop the engine — play safe.

(8) When working with the plunge cut bow saw, keep the chain guard on at all times. When cutting on the forward (plunge cutting) section of the bow, stand well away from the bottom section of the bow. This precaution also applies when using the Clearing Attachment.

(9) When limbing or pruning high branches, do not stand under the branch.

(10) When cutting, always keep one hand on the pistol grip and the other hand on the handle bar. The balance point of the saw is at the handle bar. When using the bow attachment, it is permissible to shift one hand from the handle bar to the side handle on the bow attachment.

#### b. General

The availability of various cutting attachments for the Homelite Model 5-20 Saw enables the operator to adapt his unit for capacity cutting of any kind. In a matter of minutes, one attachment may be removed and replaced with another. In addition to operation, these instructions cover the special advantages of each type of attachment. If you have never used a chain saw before, practice cutting on a small log before attempting more difficult bucking or felling cuts. Remember to operate the oil pump at frequent intervals during cutting. Proper lubrication reduces friction between the chain and the guide groove and increases the service life of these parts.

PLACE THE SPIKES OF THE SAW AGAINST THE WOOD. OPEN ENGINE THROTTLE. WHEN CHAIN REACHES FULL SPEED PIVOT SAW ON ITS SPIKES BY PULLING ON PISTOL GRIP UNTIL THE CHAIN ENGAGES WOOD.

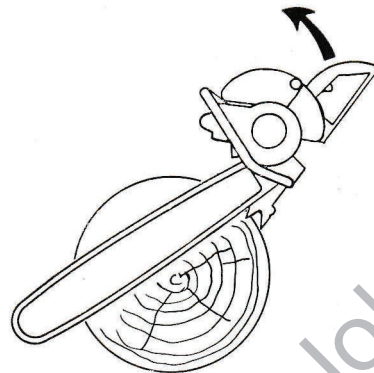
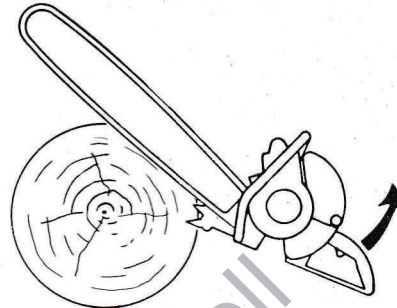

KEEP PULLING ON PISTOL GRIP TO PIVOT BLADE THROUGH THE WOOD. IF SAW JAMS IN CUT, RELEASE THROTTLE, PULL SAW FREE, AND REENGAGE IN CUT.

STOP PIVOTING BEFORE TIP OF BLADE HITS GROUND—OR WHEN YOU CAN NO LONGER PULL ON GRIP AND CUT WOOD. KEEP CHAIN RUNNING IN CUT, BUT PULL SPIKES FROM WOOD. PUSH DOWN ENGINE END TO REACH NEW PIVOT POINT. REENGAGE SPIKES AND CONTINUE TO CUT USING PIVOT ACTION.

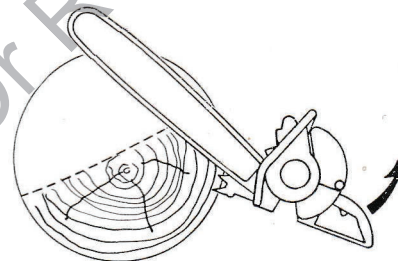

Figure 4—Pivot Action With Straight Blade

### c. Straight Blade

The cutting movement with a straight blade, called "pivot action", is fully explained in figure 4.

#### (1) FELLING OPERATION:

(a) Analyze the cutting factors—the direction in which the tree leans, the wind direction, and the desired direction of fall. Then notch the tree on the side toward which it should fall. This notch should be about  $\frac{1}{4}$  to  $\frac{1}{3}$  through the tree. (See figure 5.)

(b) After completing the notch, start the felling cut on the opposite side of the tree 2" or more above the horizontal cut of the notch, depending on the size of the tree. Engage the spiked bumper near one corner of the notch so that pivoting the saw will make the blade come parallel to the notch—**DO NOT CUT THROUGH** to the notch. Always leave a section of wood parallel to the notch to

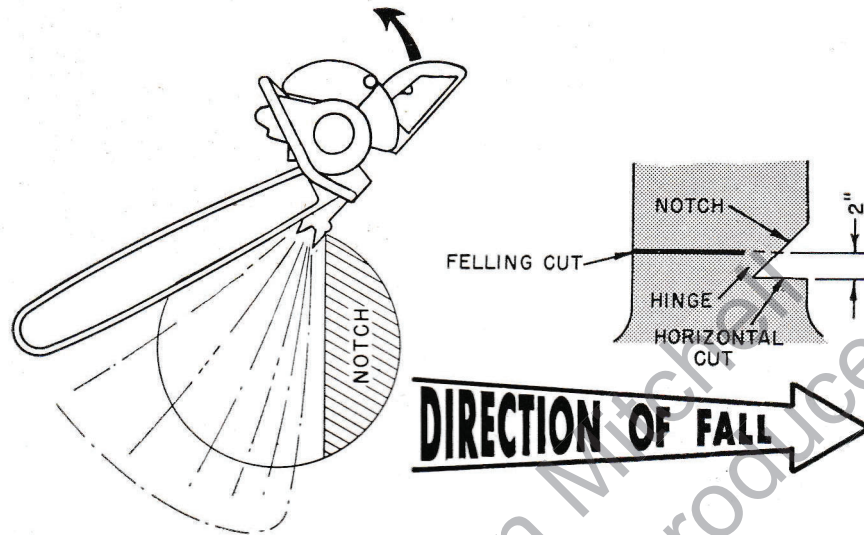

Figure 5—Notching For Directional Felling

act as a hinge. As you make the felling cut, keep glancing at the top of the tree for signs of movement. As the tree goes over, pull saw from cut and retreat to a safe position.

(c) In felling trees larger than the guide bar (figures 6 and 7) notch tree for directional felling. After notching, felling is accomplished by a series of cuts. It is very important to make the first cut in the correct position relative to the notch. The final cut must be made with the guide bar moving toward the notch to assure proper direction of fall. Use a wedge to keep the felling cut open.

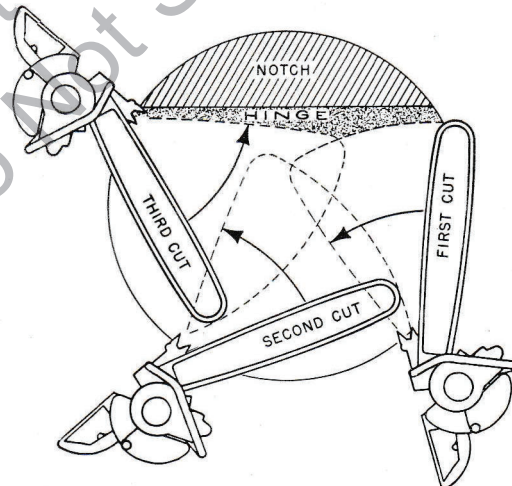

Figure 6—Felling Trees Larger Than Blade Length

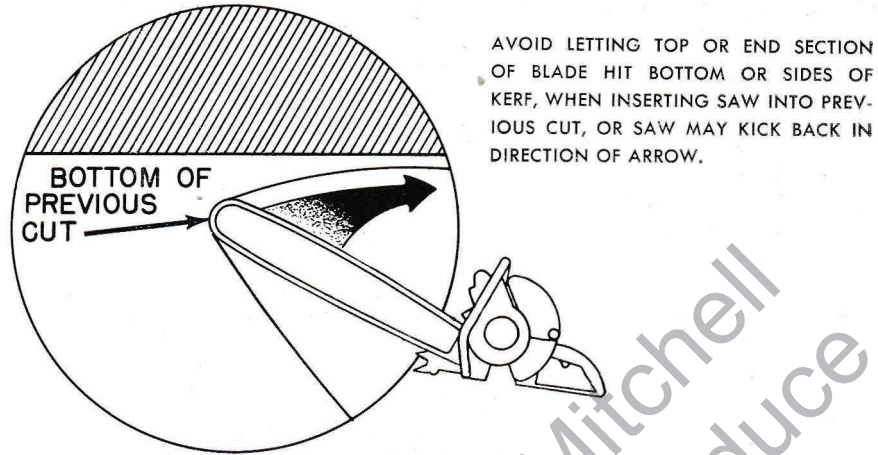

Figure 7—Safe Cutting Instruction

**(2) BUCKING AND LIMBING OPERATION:**

The position of the felled tree should determine just how to cut to avoid splitting the log or pinching the blade. If a cut is likely to close up as it is deepened, insert soft wedges to keep it open.

**d. Plunge Cut Bow Saw**

The Plunge Cut Bow Saw is designed for pinchless cutting of pulpwood and cordwood where the logs must be bucked into short lengths. Felling and bucking can be accomplished using either the bottom edge or the forward (plunge cutting) edge of the bow.

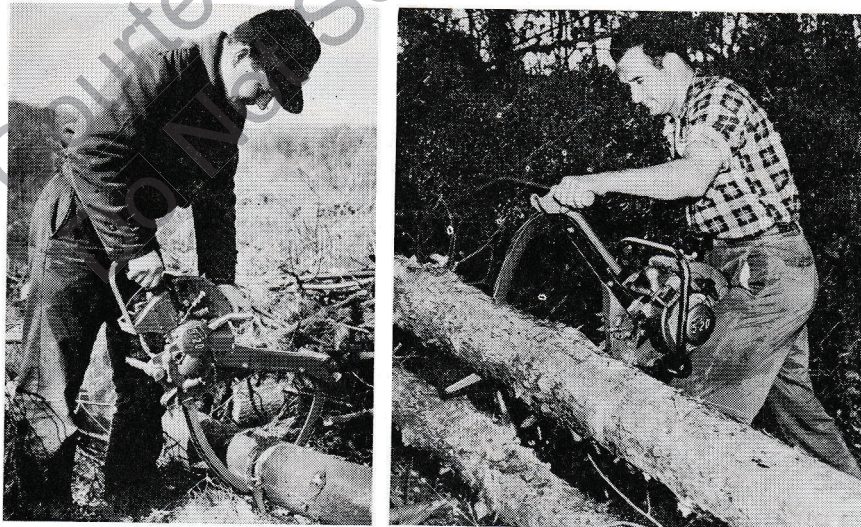

Figure 8—Plunge Cutting With Bow Attachment

(1) Pivot action (the same as with a straight blade) is used when cutting with the bottom edge. Hold the saw spikes against the wood at the start, then pivot the bow into the wood.

(2) Plunge cutting action is used with the forward section of the bow. (See figure 8.) Place the plunging spur against the side of the tree or log. Push the saw straight into the wood or use a slight pivoting action. When logs are lying on the ground, push the spur into the dirt, then pivot the chain into the log. This will keep the log from rolling with the chain. The slight curve of the bow permits cutting right down to the ground. Be careful, however, not to let the chain run into the ground.

#### e. Clearing Attachment

(1) The Clearing Attachment (Part No. A-55379) takes the stoop and squat entirely out of clearing jobs. It is designed to cut anything from twigs to eight inch diameter trees. However, the attachment can also be used to cut larger diameter wood and serves well as a general purpose tool.

(2) Use the plunge-cut method on all felling, bucking, limbing, and pruning cuts eight inches or less in diameter. Place the plunging spur (See figure 9.) against the work and depress engine throttle. Push the curved front edge of the blade straight through the wood. If desired, use a slight pivot action.

(3) When wood is too large to be cut with the front section of the attachment,



Figure 9—Bucking and Felling With Clearing Attachment

satisfactory cutting can be accomplished using the bottom section. Engage the saw spikes in the wood (same as straight blade sawing) and use pivot action to feed the chain into the wood. (See figure 4.) If the plunging spur is in the way, remove it by taking out the two screws holding the spur to the chain guide.

**f. Brush Cutter Attachment**

(1) The Model BC Brush Cutter Attachment quickly clears small saplings, brush and grass from fields and pastures, fence lines, roadsides and power line rights of way. Easily attached to the chain saw engine, this brush cutter clears up to a ten foot strip in one swath. (See figure 10.) The five foot arm makes it easy to get under overhanging branches—keeps saw out of operator's way. A special harness evenly distributes the weight of the entire unit on both shoulders.

(2) With each Brush Cutter Attachment, a Brush Cutter Instruction Book and Parts List (Part No. 22256) is furnished. This book tells you how to attach, maintain and operate the Brush Cutter and includes a complete list of replacement parts.



Figure 10—Brush Cutter In Action

## Section II MAINTENANCE

### 4. MAINTENANCE AND ADJUSTMENT

#### a. General Maintenance of Chain and Guide Bar

- (1) Clean the saw chain, guide bar and guide bar groove to remove sawdust and pitch. When wood has a high pitch content, a mixture of pitch and sawdust may clog the guide bar groove. Clean groove with gasoline or kerosene. If the chain is to be stored for any length of time, oil it thoroughly after cleaning. A dry chain rusts.
- (2) Inspect chain for damaged teeth or tight rivets; repair if necessary.
- (3) Check the chain for sharpness. Sharpen if necessary. (See paragraph 4 b.)
- (4) Fill chain oil reservoir according to instructions in paragraph 1 f.
- (5) When transporting or storing the saw, slip a sheath over the chain and guide bar as a safety precaution and to protect the chain.

#### b. Sprocket

The chain drive sprocket (see figure 2) should be inspected from time to time. If it is badly worn it must be replaced. Whenever a *new chain* is installed it is especially important that the chain drive sprocket be in good condition or the new chain might be damaged.

#### c. Chain

The cutting chain contains the pieces shown in figure 11. With each chain you receive a repair kit with a quantity of these parts. For capacity cutting with the Model 5-20 Saw, the chain must be sharpened and the depth gauges set as recommended in this section.

- (1) SHARPENING CHAIN: The best results are obtained by using a file holder. Homelite file holder (Part Number 22670) comes complete with a  $\frac{1}{4}$ "

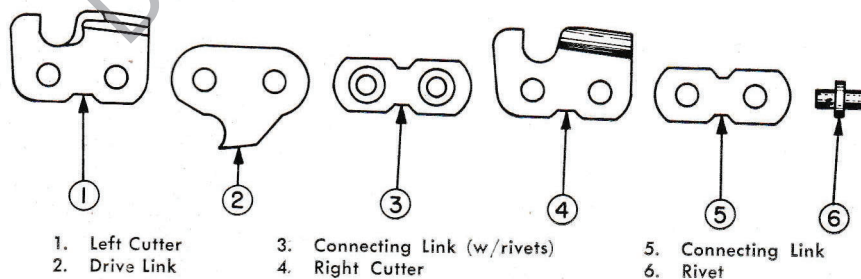

Figure 11— Chain Repair Kit Parts

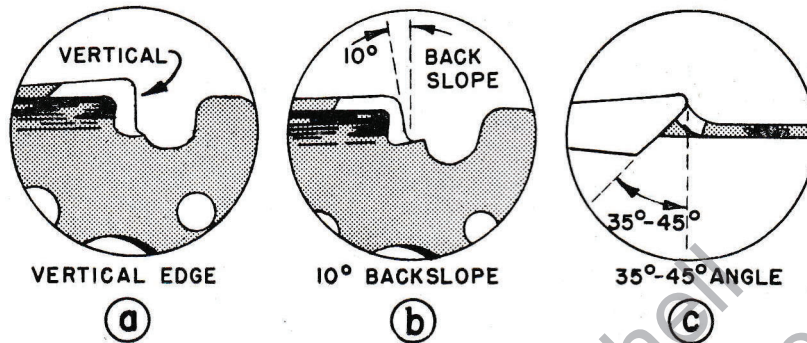

Figure 12—Filing No. 10 Chain

round file. The lines on the file holder enable you to file equal angles on both left and right cutters.

(a) Keep side of cutting edge vertical. (See figure 12a.) This permits easy feeding into the cut. It also makes the chain stay sharp longer.

(b) For hardwood or frozen timber better results are obtained by sloping the side edge about  $10^\circ$  backward (See figure 12b.) instead of keeping it vertical. This slight slope will provide a smoother cut, but requires more feeding pressure by the operator.

(c) Maintain the same top plate angle on both the left and the right cutters. (See figure 12c.) According to the type of wood to be cut, top plate angles between  $35^\circ$  and  $45^\circ$  are commonly used. Unequal angles cause the chain to run to one side and that side of the guide bar wears down faster. FOLLOW THE GUIDE LINES ON THE FILE HOLDER.

#### (2) FILING DEPTH GAUGES:

(a) The depth gauges (also called "rakers" or "stops") control the size chip the chain teeth can cut. If the gauges are too high, the chain cannot get enough bite for capacity cutting. If the gauges are filed too low, the chain will grab and jerk. New chains have the gauges filed to .038" clearance. The proper depth gauge clearances for Model 5-20 saw chain are as follows:

Hardwood	.038—.045
Hardwood-Softwood	.045
Softwood	.045—.050

(b) After filing down depth gauges be sure to round off front corners of the gauges again so they will glide over the wood instead of thumping into it.

#### d. Guide Bar

(1) The guide bar wears faster along the side which receives pressure when cutting. Therefore, if the groove in the guide bar is worn wider than approximately .082" on the bottom or cutting side, the life of the guide bar may be prolonged by reversing it top for bottom.



(2) Check the guide bar rails for uneven wear. If one rail is higher than the other, restore the rails to an even height by grinding. However, if both rails are worn so low that the chain bottoms (drags) in the groove, either replace the guide bar with a new one, or repair the worn bar by deepening (grinding) the groove. After grinding, remove all burrs from the guide bar, and clean it thoroughly. Do not ruin your chain on a worn out guide bar.

(3) If the guide bar groove is pinched so that the chain drags, open the groove.

#### e. Air Filter

(1) The air filter must be cleaned whenever the engine loses power. Under severe dusty conditions, clean the air filter daily. A dirty air filter causes the saw to run too rich (with normal carburetor adjustment), causes excessive carbonization in the engine, destroys the efficiency of the unit and may keep the engine from accelerating properly.

(2) To clean the air filter, remove two 6-32 x  $\frac{3}{8}$  screws holding air filter cap to fuel tank. (Do not lose gaskets.) Remove the filter element from the saw and immerse it in gasoline (not fuel mix). The filter must be thoroughly dry before installing it in the saw. It is a good idea to keep a clean spare filter that can be installed when necessary.

#### f. Spark Plug

(1) Spark plugs are made in wide ranges to suit different engines. The Champion HO-8A (Homelite Part No. 71530) is the proper spark plug for this engine.

(2) To remove the spark plug, remove the cylinder shield by taking out the three 8-32 spin-lock screws, twist the spark plug cover counterclockwise and pull it off the spark plug terminal nut. Remove the spark plug and gasket from the cylinder.

(3) Clean both the porcelain and the points and adjust the point gap to .025". If the points are badly burned, or if the porcelain is cracked, replace with a new Champion HO-8A spark plug with gasket. If the spark plug is wet, it indicates excess fuel in the cylinder. If the spark plug is oily there is either too much oil in the fuel mix or the engine is running rich.

(4) While the spark plug is removed from the cylinder it is easy to test ignition spark. Be sure the toggle switch is in "ON" position. Push a piece of bare wire into the spark plug cover to contact the metal spring connector on the end of the high-tension lead. Hold the spark plug cover between your thumb and forefinger. Keep your fingers away from the bare wire or you will get a shock. Hold the end of the wire  $\frac{1}{4}$ " from the cylinder. Crank the engine rapidly. If a strong spark jumps between the end of the wire and the cylinder, the magneto is working properly. If it does not, your Homelite Service Station is equipped to check the complete ignition system.

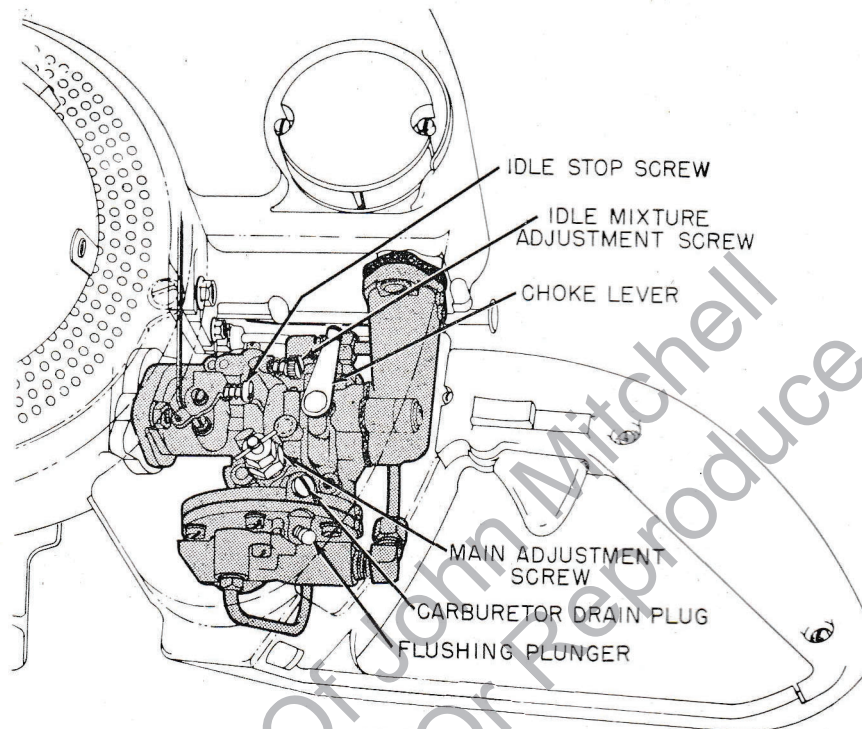

Figure 13—Carburetor Controls

(5) Reinstall spark plug with gasket in place, tighten spark plug securely in cylinder. Make certain the spark plug terminal nut is tight. Push high-tension lead onto spark plug. Twist cover clockwise.

#### g. Carburetor

There are only three adjustments on this carburetor.

Idle Mixture Adjustment

Idle Speed Adjustment

Main (or high) Speed Adjustment

- (1) Idle Mixture Adjustment is controlled by the idle mixture adjustment screw. (See figure 13.) Normal setting is approximately  $\frac{1}{2}$  to  $\frac{3}{4}$  of a turn (counterclockwise) open from the closed position.
- (2) Idle Speed Adjustment is controlled by the idle speed adjustment screw. (See figure 13.) Normal setting approximately  $\frac{3}{4}$  turn (clockwise) after screw hits stop pin.
- (3) Main (or high) Speed Adjustment is controlled by the main adjustment screw (see figure 13) with a T-handle. Normal setting is  $\frac{1}{2}$  to  $\frac{3}{4}$  turn (counterclockwise) open from the closed position.

(4) To set the carburetor adjustments use the following procedure: Set all adjustments to agree with the above positions. Start engine and let it warm up. Release throttle lock so that engine is idling and then set the idle mixture adjustment screw so engine idles smoothly. Set the idle speed adjustment screw so the chain does not rotate. Try to accelerate. If the engine falters, open (turn counterclockwise) idle mixture adjustment screw slightly until the engine accelerates properly. To set the main adjustment screw, start saw in a cut. Pull on pistol grip sufficiently to stall or jam the chain in the cut (the automatic clutch is now slipping). With the chain stalled and the trigger fully depressed (throttle wide open) adjust the T-handled main adjustment screw so the engine neither slows down nor smokes excessively but runs at the highest speed obtainable. Stall chain only long enough to get the carburetor adjusted properly.

(5) After the engine has given good performance for some time the saw may begin to run *lean*. This indicates that the felt filter in the fuel tank may be plugged with dirt. With clean fuel, a filter can be expected to last indefinitely but, with exceptionally dirty fuel, it may require changing every 3 or 4 weeks. Replace the dirty filter with a clean one as shown in figure 14. NEVER OPERATE A SAW WITHOUT A FUEL FILTER.

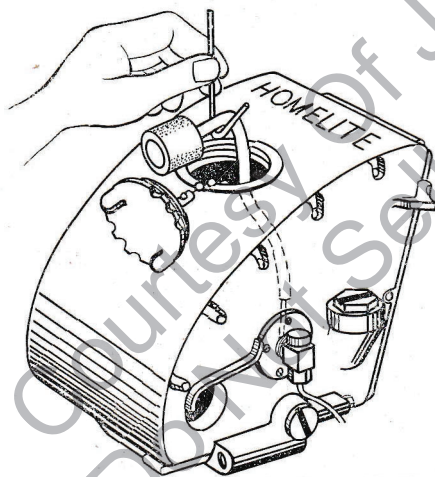

1. USE A WIRE HOOK TO LIFT FUEL STRAINER OUT THROUGH FUEL FILLER HOLE.
2. PULL DIRTY FILTER PLUG OUT OF STRAINER AND DISCARD.
3. PUSH NEW FILTER PLUG INTO END OF STRAINER. ALLOW FILTER TO PROJECT 1/16" FROM END OF STRAINER.
4. DROP STRAINER BACK INTO TANK.

Figure 14—Changing Fuel Filter

(6) Flooding of the carburetor is often caused by dirt which prevents the inlet needle from seating properly. To clean carburetor, proceed as follows. Remove spark plug [see paragraph 4f (2)] to relieve engine compression. With fuel shut-off valve open and toggle switch "OFF", remove drain plug on left side of carburetor. Depress the flushing plunger (see figure 13) and crank engine. Fuel should flow from the carburetor drain hole when flushing plunger is depressed, and stop flowing when plunger is released. If fuel does not stop flowing, repeat operation. When fuel stops flowing after plunger button is

released, lock throttle open and crank unit ten times rapidly to expell excess fuel in the cylinder. Reinstall drain plug in drain hole, and replace and tighten spark plug. Connect high-tension lead. [See paragraph 4 f (5).] Put cylinder shield back on engine and fasten with three 8-32 pan head screws.

#### h. Trouble Shooting List

<i>Trouble</i>	<i>Probable Cause</i>	<i>Remedy</i>
Will not start	Toggle switch "OFF"	Turn "ON".
	Fuel tank empty	Fill.
	Faulty spark plug	Replace.
	No spark	Test, see paragraph 4 f (4).
Does not run well	Air filter clogged	Clean, see paragraph 4 e (2).
	Fuel filter clogged	Change. See figure 14.
	Improperly mixed fuel	Drain tank and carburetor and clean.
	Faulty spark plug	Replace.
	Water or dirt in fuel	Drain tank and carburetor and clean.
	Carburetor dirty	Flush out, see paragraph 4 g (5).
Does not cut well	Carburetor out of adjustment	Readjust, see paragraph 4 g.
	Dull chain	Sharpen.
	Tight chain	Adjust tension.
	Pinched bar	Remove chain, open pinch.
	Chain reversed	Install properly, see figure 2.

Courtesy Of John Mitchell  
Do Not Sell Or Reproduce

Courtesy Of John Mitchell  
Do Not Sell Or Reproduce

**HOMELITE GUARANTEE**

We warrant each New Chain Saw manufactured by us to be free from defects in material or workmanship. This guarantee shall be effective only providing guarantee reply card is properly filled out and returned to Homelite at the time of purchase.

**HOMELITE**

a division of Textron American, Inc.

Port Chester, N. Y., U. S. A.

# HOMELITE *Carryable* PRODUCTS

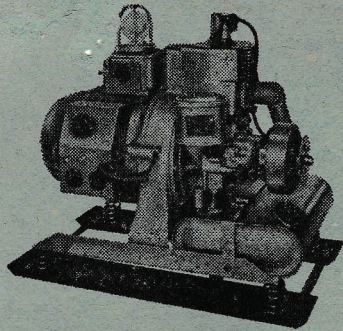

## GENERATORS

Alternating or Direct Current  
Gasoline-Engine-Driven  
Sizes: 1000 to 5000 watts  
Voltages: 6 to 220 volts  
Frequencies: 50 to 400 cycles

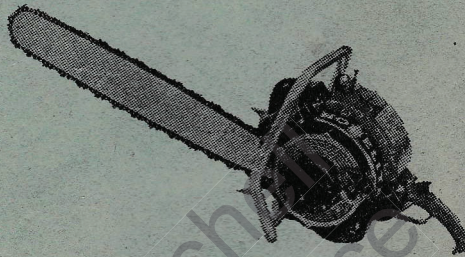

## CHAIN SAWS

Gasoline-Engine-Driven  
3½ HP to 5½ HP  
Straight Blade and Bows  
Brushcutters  
Clearing Attachments

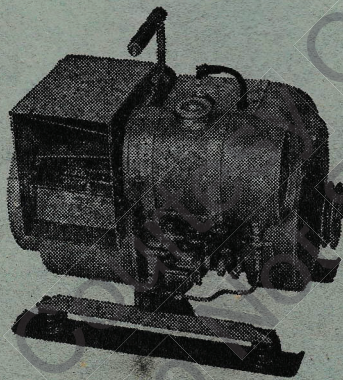

## BLOWERS

Gasoline-Engine-Driven  
Capacity: 1500 CFM

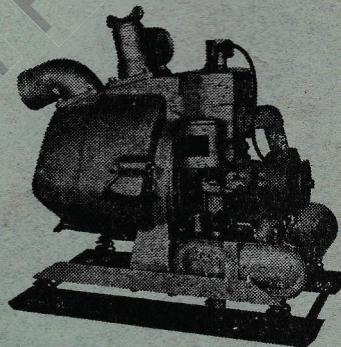

## PUMPS

Self-Priming Centrifugal  
Gasoline-Engine-Driven  
Sizes: 1½", 2", 3"  
Capacities: 5,500 to 15,000 gph

# HOMELITE

a division of Textron American, Inc.  
PORT CHESTER, N. Y., U. S. A.