

HOMELITE®

PART NO. 17080 REV. 3

Printed in U.S.A.

Price \$1.00

PARTS LIST

360

automatic
CHAIN SAW



Models:
360, 360HG,
360SL, 360W

HOMELITE TEXTRON

Homelite Division of Textron Inc.

360 Automatic Saws

FIGURE 1

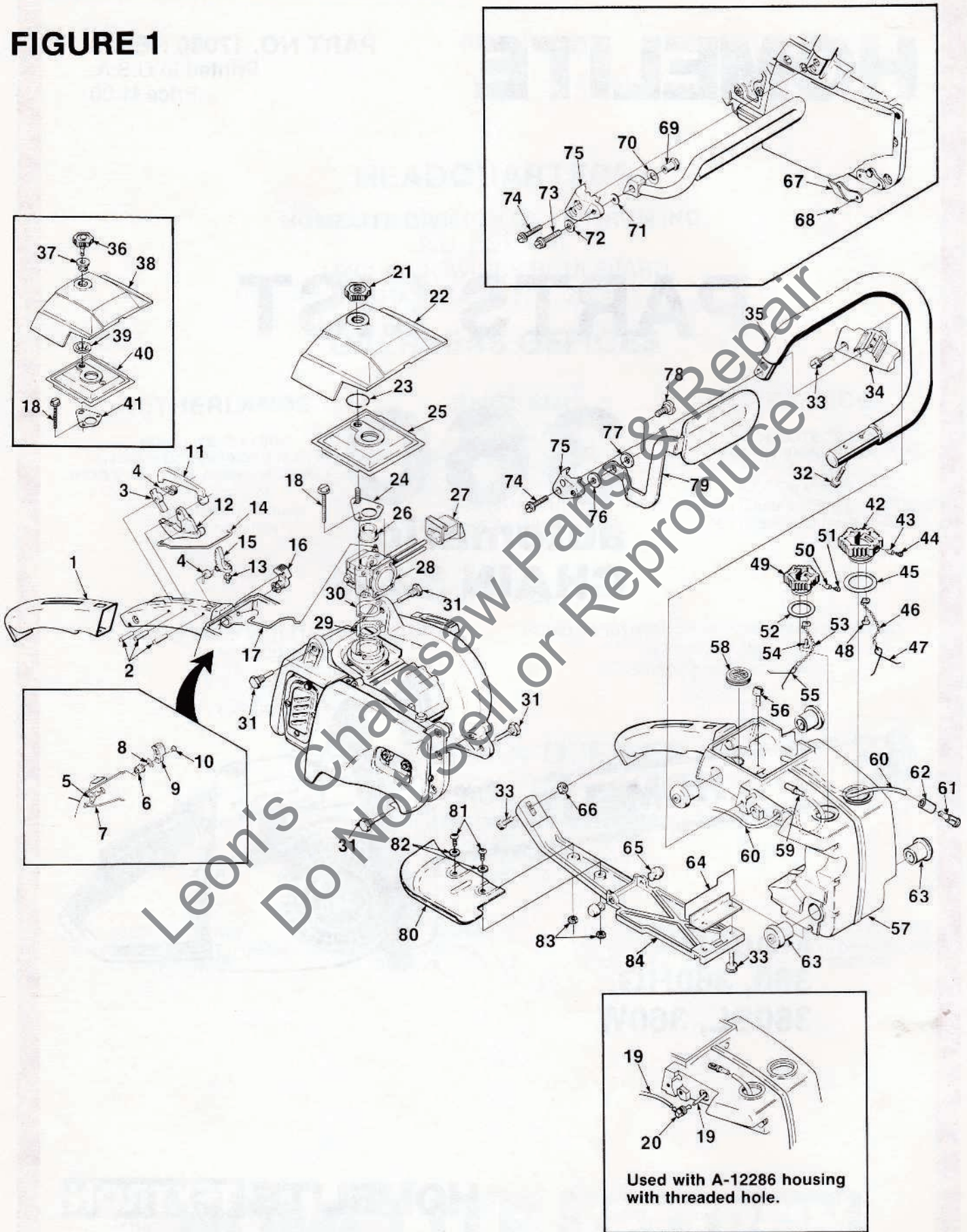

NO.	DESCRIPTION	PART NO.	QTY.	NO.	DESCRIPTION	PART NO.	QTY.
1	GRIP- Throttle handle	12049	1	44	FILTER- Filler cap	69454	1
2	PIN- Dowel	70253	3	45	GASKET- Fuel cap	69501	1
3	LEVER- Trigger lock	12092	1	46	CHAIN- Bead	69502	1
4	SPRING- Torsion	12051	2	47	RETAINER	96535	1
5	SHAFT- Choke (prior to lot # 1054)	A-12227	1	48	SCREW- Pan hd. plastite 6 x 1/4	82256-A	1
6	BUSHING (prior to lot #1054)	12147	1	49	CAP- Oil filler	A-12222	1
7	ROD- Choke (prior to lot #1054)	12149-A	1		Includes:		
8	WASHER- Wave (prior to lot #1054)	12150	1	50	VALVE- Check (oval duckbill)	69451	1
9	KNOB- Choke (prior to lot #1054)	12145	1	51	FILTER- Filler cap	69454	1
10	SCREW- 8-32 x 1/2 (prior to lot #1054)	88042	1	52	GASKET- Oil cap	12126	1
11	LOCK- Trigger	12093	1	53	CHAIN- Bead	69502	1
12	KIT- Trigger & Screw	A-12966	1	54	SCREW- Pan hd. plastite 6 x 1/4	82256-A	1
	Includes:			55	RETAINER- Cap	96535	1
13	SCREW- Trigger latch	12094-1A	1	56	SCREW- Hex sems 10-24 x 5/16	88050	2
14	ROD- Throttle	12078-1A	1	57	HOUSING- Engine	A-12286-B	1
15	LATCH- Trigger	12091-1A	1		Includes:		
16	KNOB- Choke (After lot #1054)	94765	1	58	SCREEN- Air inlet	12269	1
17	ROD- Choke (After lot #1054)	94977	1	59	FINDER- Oil	A-59009-A	1
18	SCREW- Hex sems 10-24 x 1.75	93460	2	60	TUBING- Rubber (Fuel) 10 1/2"	93112-42	2
19	TUBING- Rubber (oil) 4 3/4"	93112-19	2	61	PICK-UP- Fuel	A-69923	1
20	FITTING- Oil line	12135	1		Includes:		
	KIT- Air filter cover	A-94055-A	1	62	FILTER- Felt	64083	1
	Includes:			63	SET- Isolator- soft (set of four)	A-70623	1
21	NUT- Filter cover mtg.	A-67639-2	1		SET- Isolator- hard (set of four)	A-70622	1
22	COVER- Filter	12038-2A	1		(Alternate)		
23	RING- Retaining	58319-A	1	64	DEFLECTOR- Air (exhaust)	A-12153	1
24	BRACKET- Mounting cover	A-93240	1	65	BUMPER	12096	2
25	FILTER- Air	A-12225-1	1	66	NUT- Hex 10-24	70810	1
26	BUSHING- Flange	12109-1	1		KIT- Hand guard	A-93967-A	1
27	GROMMET- HI-LOW	12054	1		Includes:		
28	CARBURETOR- (HDC-39-A)	A-97801	1	67	STOP- Chain	70705	1
29	BUSHING	A-70923-A	1	68	SCREW- Hex sems 8-32	88042	2
	Includes:			69	SPACER- Nut (prior to lot #9240)	12240	1
30	GASKET	70743-A	1	70	WASHER- Cupped spring		
	SET- Isolator pin	A-70624-A	1		(prior to lot #9240)	12239	1
	Includes:			71	WASHER (prior to lot #9240)	83056	1
31	PIN- Isolator	12100-B	4	72	WASHER (prior to lot #9240)	12296	1
32	SCREW- Soc. hd. 10-24 x 7/8	82262	4	73	SCREW- Hex sems 10-24 x 1 1/4		
33	SCREW- Hex sems 10-24 x 3/4	88051	3		(prior to lot #9240)	88054	1
34	BRACKET- Handle bar	12059-2A	1	74	SCREW- Hex sems 10-24 x 1 3/8	88055	2
35	HANDLE BAR	A-12107-A	1	75	BRACKET- Hand guard	12238-3	1
36	NUT- Filter cover mounting (Note 1)	A-12112	1	76	WASHER	94867	1
37	BUSHING- Nylon (Note 1)	12110	1	77	WASHER- Belleville	70788	1
38	COVER- Air filter (Note 1)	A-94055-A	1	78	SCREW- Shoulder	93914	1
39	NUT- Push on spring (Note 1)	12140	1	79	GUARD- Hand	A-93968-A	1
40	FILTER- Element air (Note 1)	A-12225	1	80	KIT- Right hand guard	A-12267-B	1
41	PLATE- Spring (Note 1)	12117-1	1		Includes:		
42	CAP- Fuel filler	A-69500-A	1	81	SCREW- Hex hd. cap	82275	2
	Includes:			82	WASHER	84003	2
43	VALVE- Check (oval duckbill)	69451	1	83	NUT- Center lock #10-24	81208	2
				84	BRACE- Handle	12042-2	1

NOTE 1: Used with units prior to lot #8138.

360 Automatic Saws

FIGURE 2

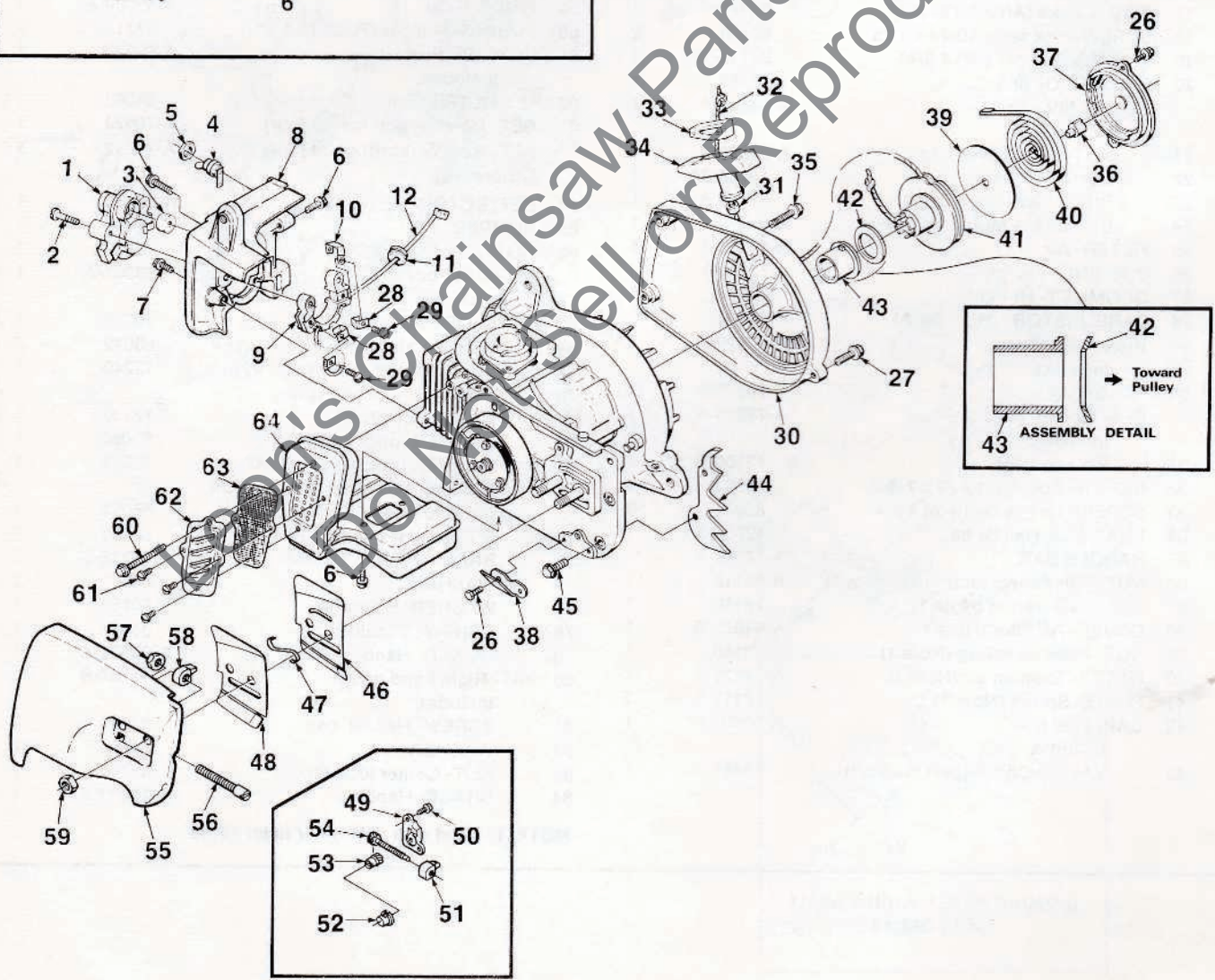
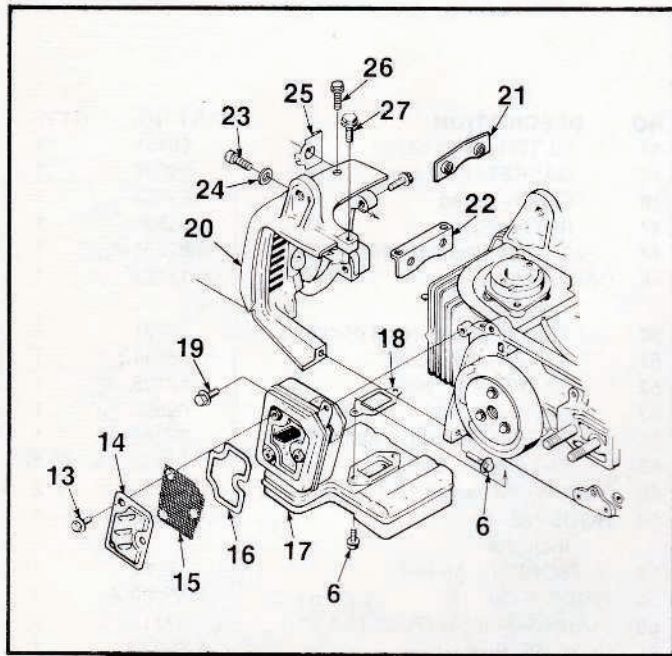

NO.	DESCRIPTION	PART NO.	QTY.	NO.	DESCRIPTION	PART NO.	QTY.
1	TRANSFORMER Includes:	A-12299-AS	1	32	ROPE- Starter (38" #4)	94564	1
2	SCREW	95270	2	33	INSERT- Rope retaining	70018-A	1
3	GROMMET	12191	1	34	GRIP- Starter rop	A-69962-B	1
4	SWITCH- Grounding Includes:	A-57650-3A	1	35	SCREW- Hex sems 10-24 x 1 3/8	88055	1
5	NUT	72084-1A	1	36	LOCK- Spring	65102	1
6	SCREW- Hex sems 10-24 x 3/4	88051	4	37	COVER- Starter	12523	1
7	SCREW- 10-24 x 1 1/4 (after lot #C-320)	88054	3	38	STOP- Chain	70705	1
8	SHIELD- Cylinder (after lot #C-320)	94779-2	1	39	SPRING- Shield	12052	1
9	RECEPTACLE- Transformer	A-70088	1	40	SPRING- Rewind	65107	1
10	CONTACT- Ground	70720	1	41	PULLEY & CUP	A-12214-A	1
11	GROMMET	68279	1	42	WASHER- Spring	70842	1
12	LEAD- Low tension	A-12719-B	1	43	BUSHING- Starter	12053	1
13	SCREW- Hex sems 8-32 x 3/8 (Prior to lot #C-320)	88041	3	44	BUMPER- Spiked (accessory) Includes:	A-12272-C	1
14	PLATE- Exhaust (W) (prior to lot #C-320)	12176-1	1	45	SCREW- Hex hd. 10-24 x 3/8	88048	2
15	SPARK ARRESTOR (Accessory) (prior to lot #C-320)	D-12270-B	1	46	PLATE- Guide bar (Inner)	70397	1
16	GASKET- Exhaust plate (prior to lot #C-320)	12173	1	47	SPRING- Guide bar	69966	1
17	MUFFLER- 360 AO (prior to lot #C-320) Includes:	A-70784	1	48	PLATE- Guide bar (Outer)	70398	1
18	GASKET- Muffler	12080-A	1	49	COVER- Gear (Note 1)	12134	1
19	SCREW- Hex sems 10-24 x 1/2 (prior to lot #C-320)	88049	1	50	SCREW- Pan hd. mach 6-32 x 3/8 (Note 1)	82251	2
20	SHIELD- Cylinder (prior to lot #C-320) Includes:	A-93128-A	1	51	PIN- Guide bar adjusting (Note 1)	65112-1	1
21	PLATE- Nut (prior to lot #C-320)	93075	1	52	BUSHING (Note 1)	70693	1
22	BRACKET- Cylinder (prior to lot #C-320)	93063	1	53	ADJUSTER- Guide bar (Note 1)	A-70694	1
23	SCREW (prior to lot #C-320)	69919	2	54	SCREW- Guide bar adjusting (Note 1)	A-12132	1
24	WASHER (prior to lot #C-320)	12071	2	55	COVER- Drivecase Includes:	A-93930-2	1
25	PLATE- (Run - Stop) (prior to lot #C-320)	12793-A	1	56	SCREW- Guide bar adjusting	93962	1
26	SCREW- Hex hd. w/washer 8-32 x 1/2	88042	2	57	NUT- Centerlock (10-32)	81206	1
27	SCREW- 10-24 x 1" hex sems	88053	2	58	PIN- Guide bar adjusting	65112-1	1
28	CONTACT- Transformer	12788	2	59	NUT- Hex 5/16-18	81196	2
29	SCREW- Plastite pan 6 x 3/8	82215	2	60	SCREW (After lot #C-320)	93460	1
30	HOUSING- Rewind starter Includes:	A-12114-A	1	61	SCREW- (After lot #C-320)	82370	3
31	BUSHING- Rope	65185	1	62	PLATE- Exhaust (After lot #C-320)	94796-1	1
				63	SPARK ARRESTOR SCREEN (Opt.) (Note 2) (After lot #C-320)	94797	1
				64	MUFFLER (After lot #C-320)	A-94785-1	1

NOTE 1: Use prior to Lot #8044.

NOTE 2: Spark arrestor screen 94797 will come with muffler 94796-1 for the 360 W units.

360 Automatic Saws

FIGURE 3

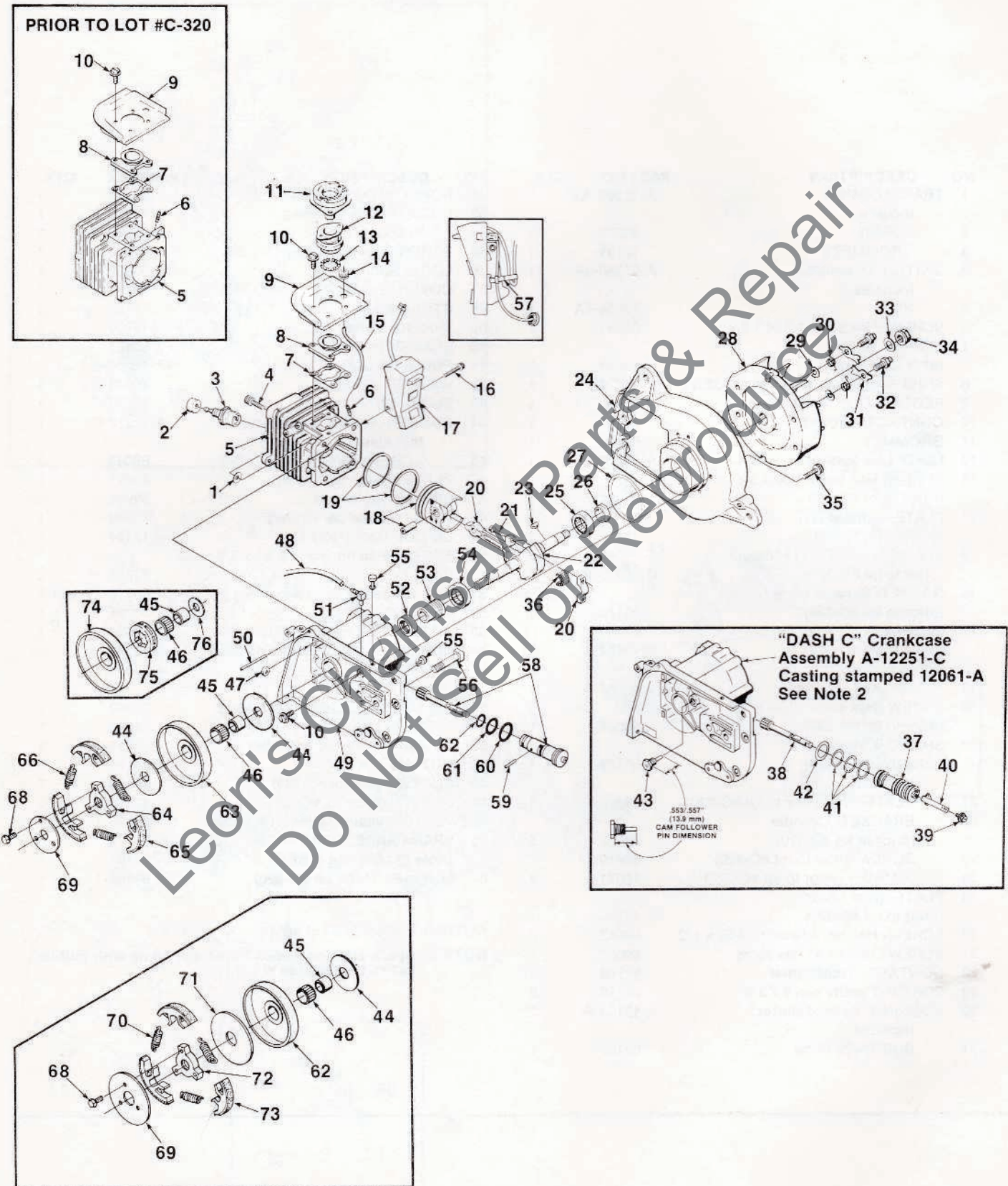

NO.	DESCRIPTION	PART NO.	QTY.	NO.	DESCRIPTION	PART NO.	QTY.
1	WASHER	12021	4	49	CRANKCASE (Note 1)	A-12251-E	1
2	GROMMET- Spark plug	12191	1		Includes:		
3	SPARK PLUG (Champ CJ6)	63547-S	1	50	PIN- Dowel (.125 x 1.375)		
4	SCREW- Soc. hd. cap #10-24 x 7/8	82262	4		Install in crankcase	See Note *	1
5	CYLINDER (Prior to lot #C-320)	A-70716-A	1		for chain brake only		
	(Includes index Nos. 6 thru 10)			51	FITTING- Oil line	50558	1
	CYLINDER (After lot #C-320)	A-94781	1	52	SEAL- (Double lips)	70729	1
	Includes:			53	WORM- Gear	12071	1
6	FITTING	69833	1	54	BEARING- Roller	63867	1
7	GASKET- Intake adapter	70714	1	55	BUMPER	12096	2
8	MANIFOLD- Intake	70715	1	56	BOLT- Guide bar 5/16"	58753	2
9	DEFLECTOR- Air (Intake)	12161-1B	1	57	CABLE TIE- Module lead	12298	1
10	SCREW- Hex hd. w/washer 8-32 x 1/2	88042	5	58	PUMP- Automatic Oil (Note 1)	A-70962	1
11	FLANGE- Carburetor connector	A-70246-B	1		Includes:		
12	CONNECTOR- Carburetor	12048-C	1	59	PIN- Pump	70920	1
13	SPRING- Garter	12291	1	60	"O" RING	70921	1
14	GROMMET	62740	1	61	"O" RING	12853	1
15	LINE- Pulse 5 1/2"	93112-22	1	62	"O" RING	12095	1
16	SCREW- Hex sems 8-32 x 1 1/4	88045	2	63	SPROCKET & DRUM		
17	MODULE & CORE	12669-A	1		7T, 3/8 P (Note 2)	A-95465	1
18	PISTON & PIN	A-12257-A	1		KIT- Clutch conversion	A-93867-A	1
	Includes:				Includes:		
19	PISTON RING	12040	2	64	SPIDER- Clutch (After lot #C-320)	96448	1
20	ROD- Connecting	A-12068-1	1	65	SHOE- Clutch (After lot #C-320)	A-96447-A	3
	Includes:			66	SPRING- Extension		
21	SCREW- Soc. hd. 80-32 x 9/16	69919	2		(After lot #C-320)	96451	3
22	CRANKSHAFT	12037-1	1	67	COVER- Clutch (After lot #C-320)	96449	1
23	KEY- Woodruff	75078	1	68	SCREW- Hex sems 8-32 x .375	88041	1
24	PLATE- Back	A-12204-A	1	69	COVER- Clutch (Prior to lot #C-320)	93628	1
	Includes:			70	SPRING- Clutch (Prior to lot #C-320)	93638-A	3
25	BEARING- Roller	63867	1	71	WASHER- Thrust (Prior to lot #C-320)	93643	1
26	SEAL	12282-A	1	72	SPIDER- Clutch (Prior to lot #C-320)	93636	1
27	"O" RING	58785	1	73	SHOE- Clutch (Prior to Lot #C-320)	A-93632-B	3
28	ROTOR	12101-A	1	74	DRUM & HUB (Note 2)	A-94302	1
29	WASHER- Lock #10	83046	2	75	SPROCKET & RIM 7T 3/8 P		
30	SPRING- Starter pawl	12056	2		(Primary source)	95058-A	1
31	PAWL- Starter	12056	2	76	WASHER- Thrust (Inner)		
32	STUD- Starter pawl	65109	2		(Prior to Lot #C-320)	58833-1	1
33	WASHER- 3/8"	95479-A	1				
34	NUT- 3/8 - 24	81255	1				
35	SCREW- Hex sems 10-24 x 3/4	88051	5				
36	ROLLERS- Needle (Set of 25)	A-12913	1				
37	PUMP- Automatic Oil (Note 1)	A-12201-A	1				
	Includes:						
38	PLUNGER- Oil pump	A-12202	1				
39	SCREW- Hex sems 8-32 x 3/8	88041	1				
40	LEVER- Oil Adjustment	12141	1				
41	"O" RING	12095	3				
42	"O" RING	12155	1				
43	PIN & PLUG (Note 1)	A-12144	1				
44	WASHER- Thrust	63860	2				
45	RACE- Inner	65985-B	1				
46	BEARING- Needle	64124	1				
47	NUT- Centerlock #10-24	81208	4				
48	TUBING- Rubber (Oil) 4 3/4"	93112-19	1				

*See note, Page 9, Figure 4.

NOTE 1: Factory - built units up to lot #8249 used crankcase A-12251-C plus the adjustable type oil pump and related parts called out in the inset drawing. For all saws after Lot No. 8248, or whenever a replacement crankcase is required and only the dash -D (assembly A-12251-D, casting 12061-C) is available, install only those parts called out in the main drawing (particularly index numbers 10, 49, and 58 thru 62.)

NOTE 2: Can be used only with 3- shoe clutch.

360 Automatic Saws

FIGURE 4

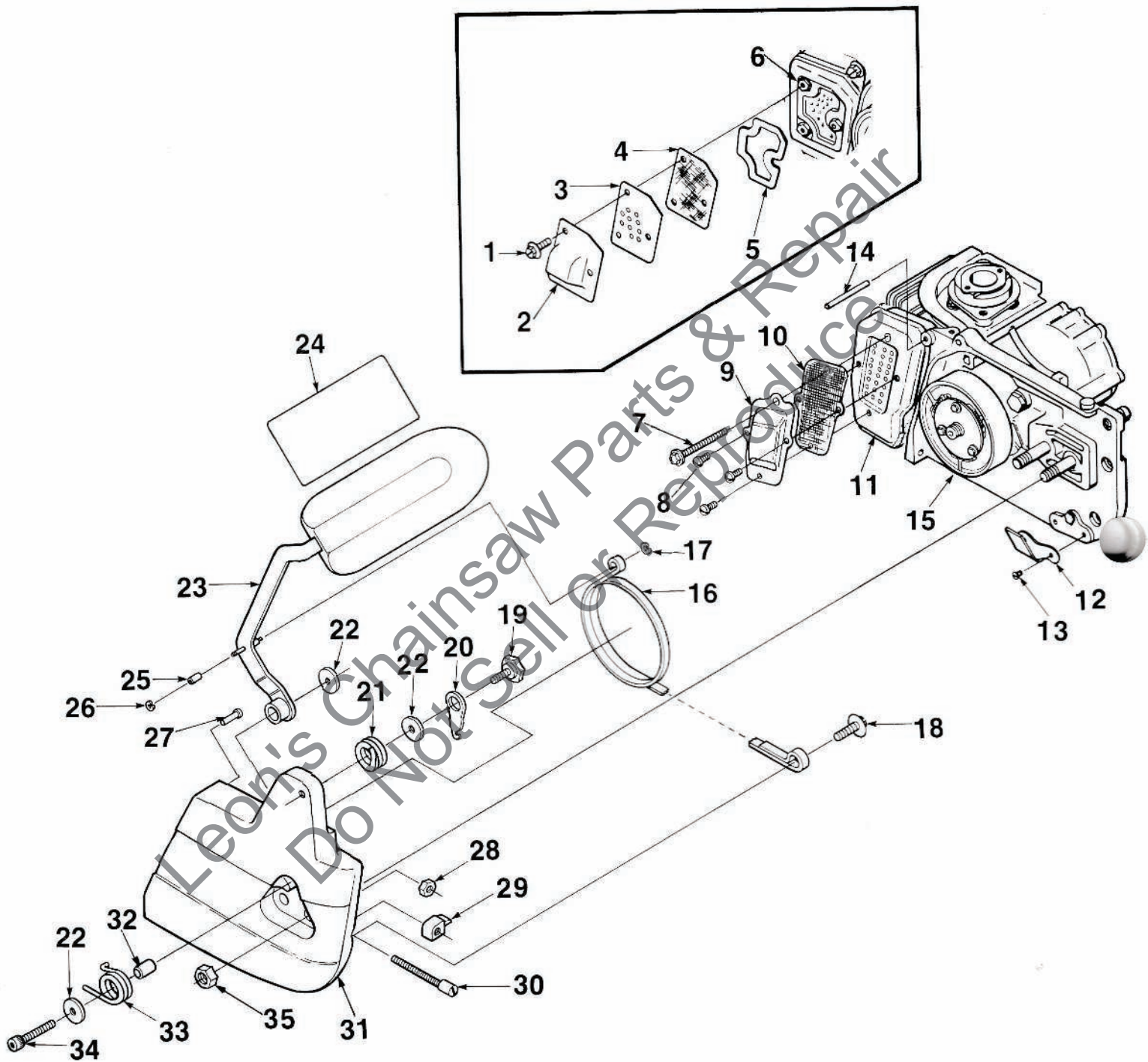

360 Automatic Saws

FIGURE 4

NO.	DESCRIPTION	PART NO.	QTY.	NO.	DESCRIPTION	PART NO.	QTY.
1	SCREW- Hex sems, 8-32 x 3/8 (prior to lot #C-320)	88041	3	18	SCREW- Pan hd. 1/4-20 x 5/8	82258	1
2	PLATE- Muffler exhaust (prior to lot #C-320)	12195-1	1	19	SCREW- Shoulder	93773	1
3	BAFFLE (prior to lot #C-320)	12119	1	20	LEVER- Locking	93602-A	1
4	ARRESTOR- Spark (accessory) (prior to lot #C-320)	D-12270-B	1	21	SPRING- Locking lever	93600-B	1
5	GASKET- Exhaust plate (prior to lot #C-320)	12173	1	22	WASHER	93282	3
6	MUFFLER (prior to lot #C-320) Includes: GASKET- Muffler (shown on Fig. 2) (prior to lot #C-320)	A-12265	1	23	LEVER- Brake w/guard Includes: DECAL	A-97221	1
7	SCREW (After lot #C-320)	12080-A	1	24	BEARING- Roller	96990-A	1
8	SCREW (After lot #C-320)	93460	1	25	"E" RING	93625	1
9	PLATE- Exhaust (After lot #C-320)	82370	3	26	SLEEVE- Headed	70925	1
10	SCREEN- Spark arrestor (Opt.) (After lot #C-320)	94795-1	1	27	NUT- Centerlock	70313	1
11	MUFFLER (After lot #C-320)	94797	1	28	PIN- Guide bar adjusting	81206	1
12	STOP- Chain	94785-1	1	29	SCREW- Guide bar adjusting	65112-1	1
13	SCREW- Hex hd. sems 8-32 x 1/2 KIT- Chain brake Includes:	83042	1	30	COVER- Drivecase	93962	1
14	PIN- Dowel (.125 x 1 3/8) (Note 1)	A-93693-A	1	31	SLEEVE- Lever	93648-1	1
15	DRUM & HUB	64870	1	32	SPRING- Brake lever	93296	1
16	BRAKEBAND Includes:	A-93630-2	1	33	SCREW- Soc cap hd.	93603	1
17	"E" RING	A-94561	1	34	NUT- Hex 5/16-18	80428-1	1
		69599	1	35		81196	2

NOTE 1: Pin #14 supplied loose in SL chain brake kit and 360 service crankcase assy, not available separately. For chain brake mounting only, press pin into hole provided in crankcase boss until there is .375 (.095 MM) remaining for engagement of pin in chainbrake drivecase cover, pin is required only for chainbrake.

360 Automatic Saws

FIGURE 5

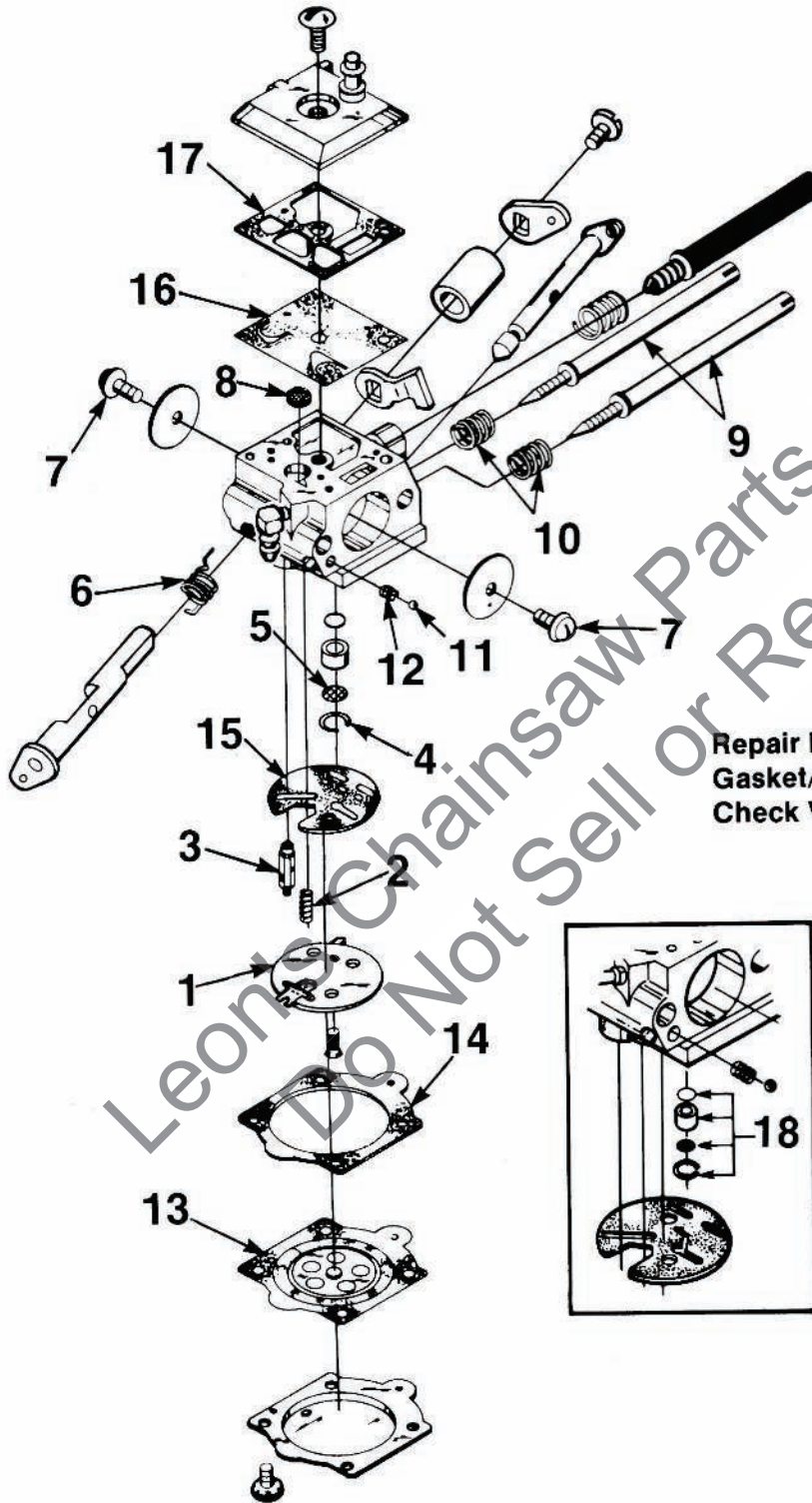

CARBURETOR
HDC-39A
A-97801

- | | |
|------------------------------------|---------|
| Repair Kit (Incl. 1-17) | 93205-A |
| Gasket/Diaphragm Kit (Incl. 13-17) | 93754 |
| Check Valve Repair Kit (Incl. 18) | 93910-A |

Leon's Chainsaw Parts & Repair
Do Not Sell Or Reproduce

TOOLS

ANVIL- Bearing removal (crankcase)	23846-1
ANVIL- Bearing removal (Crankcase & Backplate)	23846-2
KEY- Hex 5/32 (Cyl. & Handle bar)	22126
KEY- Hex 9/64 (HG-SL)	23528
PULLER- Rotor	A-24290
Includes:	
SCREW- Rotor removal	24301
RING- Retaining	67912
SHIM- Yellow plastic (.020) (air gap)	24853
SLEEVE- Seal assembly (Crankcase & Backplate)	23759
SLEEVE- Seal removal (Crankcase)	23136-6
TOOL & PLUNGER- Piston pin	A-24871
Wrench- Socket	68651
WRENCH- Spanner ("S" Clutch)	A-93791
Includes:	
PIN	23717-A
SCREW DRIVER	24541
CLUTCH TOOL- (3 shoe-clutch)	A-17146
GREASE- Multi use	17193

ACCESSORIES

ADHESIVE- Zip grip	70627
BUMPER- Spiked	DA-12272-E
EXCHANGER- Heat	A-94284-B
KIT- Chain brake	A-93693-A
KIT- Hand guard	A-93967-A
SAFE•T•TIP (STD)	A-70790-B
KIT- Guide bar insert	A-96612
KIT- Sprocket repair	A-69496-B
RUBBER- Tubing 10'	93112-99
ROPE- Starter #4 250 FT. reel	68848
SET- Isolator- hard (set of four)	A-70622
SPRAY CAN- Red	23475

NOTE: Alignment plug required for A-12201-A oil pump only.

BAR & CHAIN COMBINATIONS

BAR LENGTH & TYPE	BAR NUMBER	CHAIN DESCRIPTION	CHAIN NO. (BLISTER PACK)	CHAIN NO. (BOXED)
16" PT GW SP	PT-16381-G5	38-ME50-59	D-92428-A	J1-92059-LB
	GW-16001-G5	38-ME50-59		
	SP-16381-H5	38-ME50-59		
20" PT GW SP	PT-20381-G5	38-ME50-70	D-92431-A	J1-92070-LB
	GW-20001-G5	38-ME50-70		
	SP-20381-H5	38-ME50-70		
24" PT GW SP	PT-24381-G5	38-ME50-81	D-92432-A	J1-92081-LB
	GW-24001-G5	38-ME50-81		
	SP-24381-H5	38-ME50-81		

HEADQUARTERS

HOMELITE DIVISION OF TEXTRON INC.

P.O. BOX 7047

14401 CAROWINDS BOULEVARD

CHARLOTTE, N.C. 28241

OVERSEAS OFFICES

NETHERLANDS

HOMELITE TEXTRON
DIVISION OF TEXTRON ATLANTIC
(HDQS. — Europe, Africa and Middle East)
Haverstraat 24
2153 GB Nieuw Vennepe
The Netherlands

ENGLAND

HOMELITE
DIVISION OF TEXTRON LIMITED
UNIT 22
Hither Green Industrial Estate
Clevedon, NR, Bristol
Avon, BS 21 6XU England

FRANCE

HOMELITE TEXTRON
UNE DIVISION DE TEXTRON
S.A.R.L.
Z.I. Du Vert-Galant
Rue Du Chateau/Rue De La Garenne
95310 Saint-Quen-L'Aumone
France

AUSTRALIA

HOMELITE DIVISION OF TEXTRON PACIFIC LIMITED
HEADQUARTERS
22 Tera - Cotta Drive
Blackburn, 3130
Victoria, Australia

HOMELITE DIVISION OF TEXTRON PACIFIC LIMITED
45 Robinson Road
Geebung, Queensland, 4034
Australia

CANADIAN OFFICES

HOMELITE
DIVISION OF TEXTRON CANADA LIMITED
1850 55th Avenue
Lachine, Quebec, Canada
H8T 3J5

3260 Viking Way
Richmond, British Columbia
V6V 1N6

16520, 111th Avenue
Edmonton, Alberta
T5M 3V8

37 Densley Avenue
Toronto, Ontario
M6M 2P5

45 Brandon Street
Moncton, New Brunswick
E1C 7E7

HOMELITE **TEXTRON**

Homelite Division of Textron Inc.