

parts list

# 350

# automatic

# chain saws

# HG

# SL

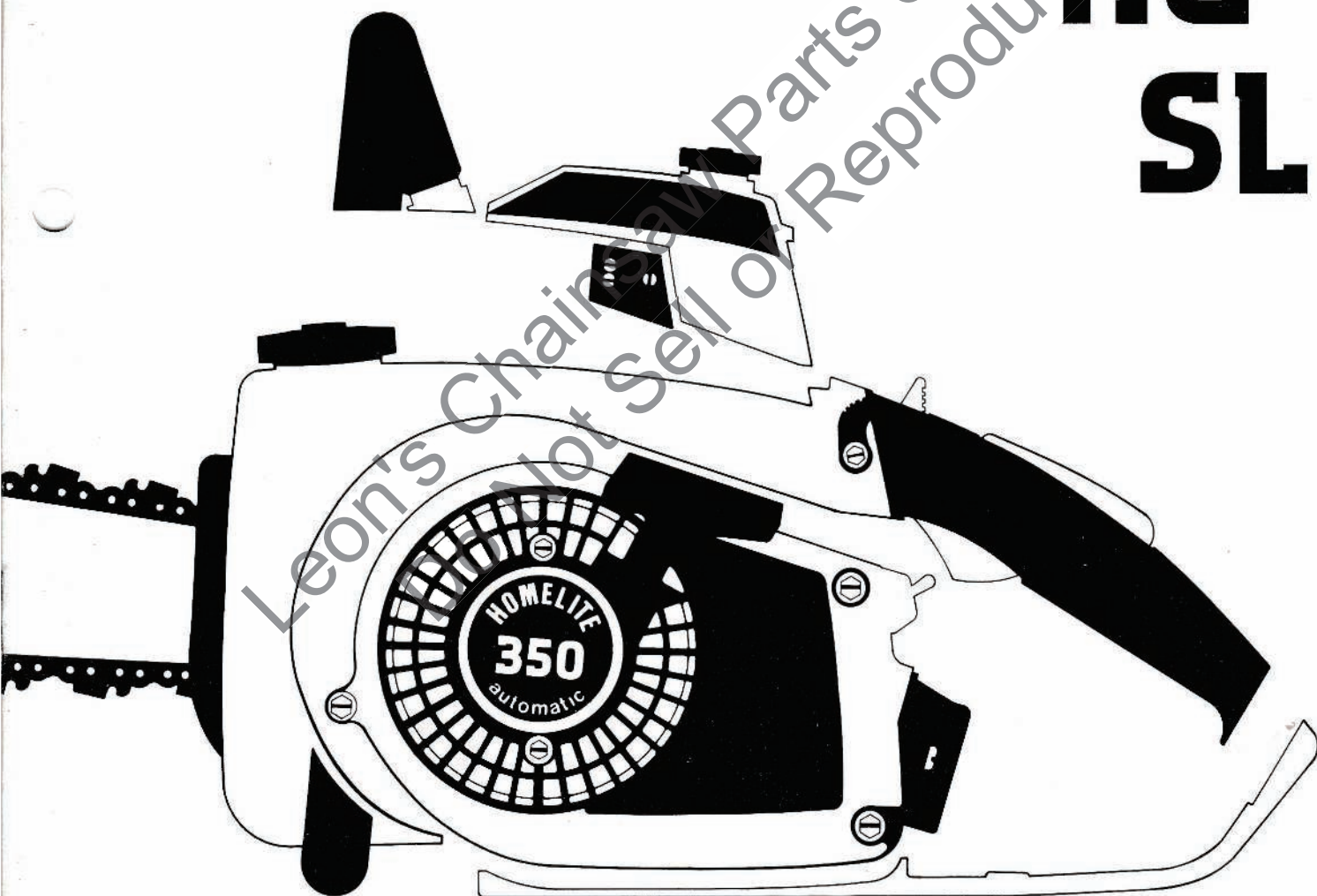

printed in U.S.A.



price .35

part no. 24820 rev. 1

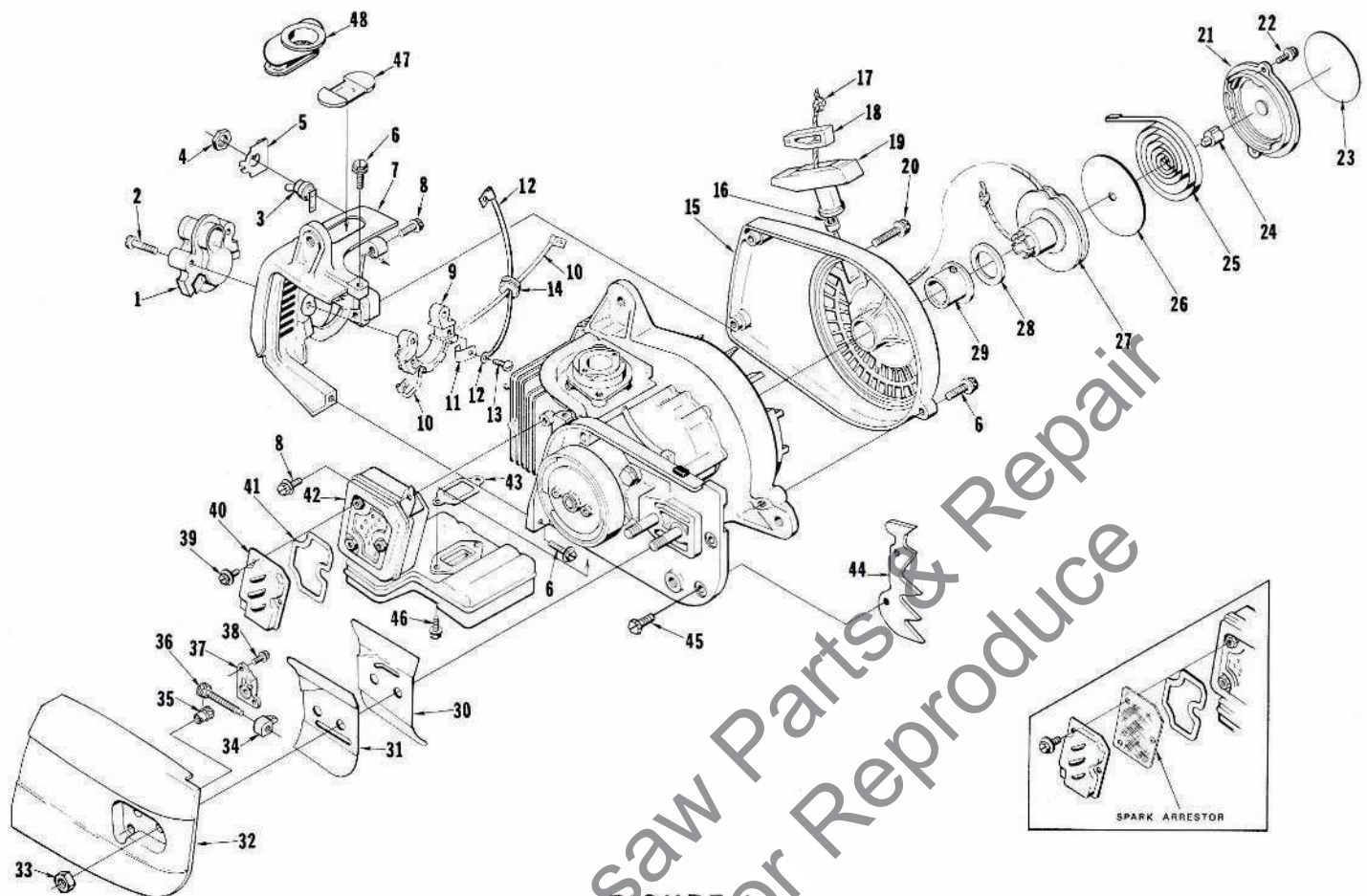

FIGURE 1

No.	Description	Part No.	Qty.	No.	Description	Part No.	Qty.
1	TRANSFORMER	A-12299	1	25	SPRING - rewind	65107	1
2	Includes: SCREW - Plastite	12791-A	2	26	SHIELD - spring	12052	1
	GROMMET - not shown	12191	1	27	PULLEY & CUP	A-12214	1
3	SWITCH - grounding	A-57850-3	1	28	SHIELD - pulley	12089	1
4	Includes: NUT	72084-A1	1	29	BUSHING - starter cup	12053	1
* 5	"ON-OFF" PLATE	12793-A	1	30	PLATE - guide bar (inner)	12162	1
6	SCREW - hex hd. w/washer 10-24 x 3/4	88022	4	31	PLATE - guide bar (outer)	12163	1
7	SHIELD - cylinder	12074-2	1	32	COVER - drivecase	A-12295-1	1
8	SCREW - hex hd. w/washer 10-24 x 1/2	88024	2	33	NUT - hex 5/16-18	81196	2
9	RECEPTACLE - transformer	12629	1	34	PIN - guide bar adjusting	12133-1	1
10	LEAD - low tension	A-12719	1	35	ADJUSTER - guide bar	A-12137	1
11	CONTACT - transformer	12788	2	36	SCREW - guide bar adjusting	A-12132	1
12	LEAD - ground	A-12718	1	37	COVER - gear	12134	1
13	SCREW - Plastite pan hd. 6 x 3/8	82215	2	38	SCREW - pan washer hd. 6-32 x 3/8	82251	2
14	GROMMET	68279	1	39	SCREW - 8-32 x 3/8	88026	3
15	HOUSING - rewind starter	A-12114-1	1	40	PLATE - exhaust	12176-1	1
16	Includes: BUSHING - rope	65185	1	41	GASKET - exhaust plate	12173	1
* 17	ROPE - starter (40" #4)	12972	1	42	MUFFLER	A-12265	1
18	INSERT - rope retaining	68837	1	* 43	Includes: GASKET - muffler	12080-A	1
19	GRIP - starting rope	64155-A	1	* 44	BUMPER - spiked (accessory)	A-12272-A	1
20	SCREW - hex hd. w/washer 10-24 x 1-1/4	88023	1	45	Includes: SCREW - hex hd. 10-24 x 3/8	88031	2
21	COVER - starter	12523	1	46	SCREW - hex hd w/washer 10-24 x 5/8	88020	2
22	SCREW - hex hd. w/washer 8-32 x 1/2	88027	2	47	PLUG - cylinder shield	12283	1
23	DECAL - starter cover	12192	1	48	HEAT EXCHANGER (see note)	12253	1
24	LOCK - spring	65102	1		SPARK ARRESTOR (accessory)	12270	1

Note: When using Heat Exchanger, index #48, the Cylinder Shield Plug, index #47, and the Air Inlet Screen, index #51 shown on Fig. 2, must be removed.

\* Denotes new parts

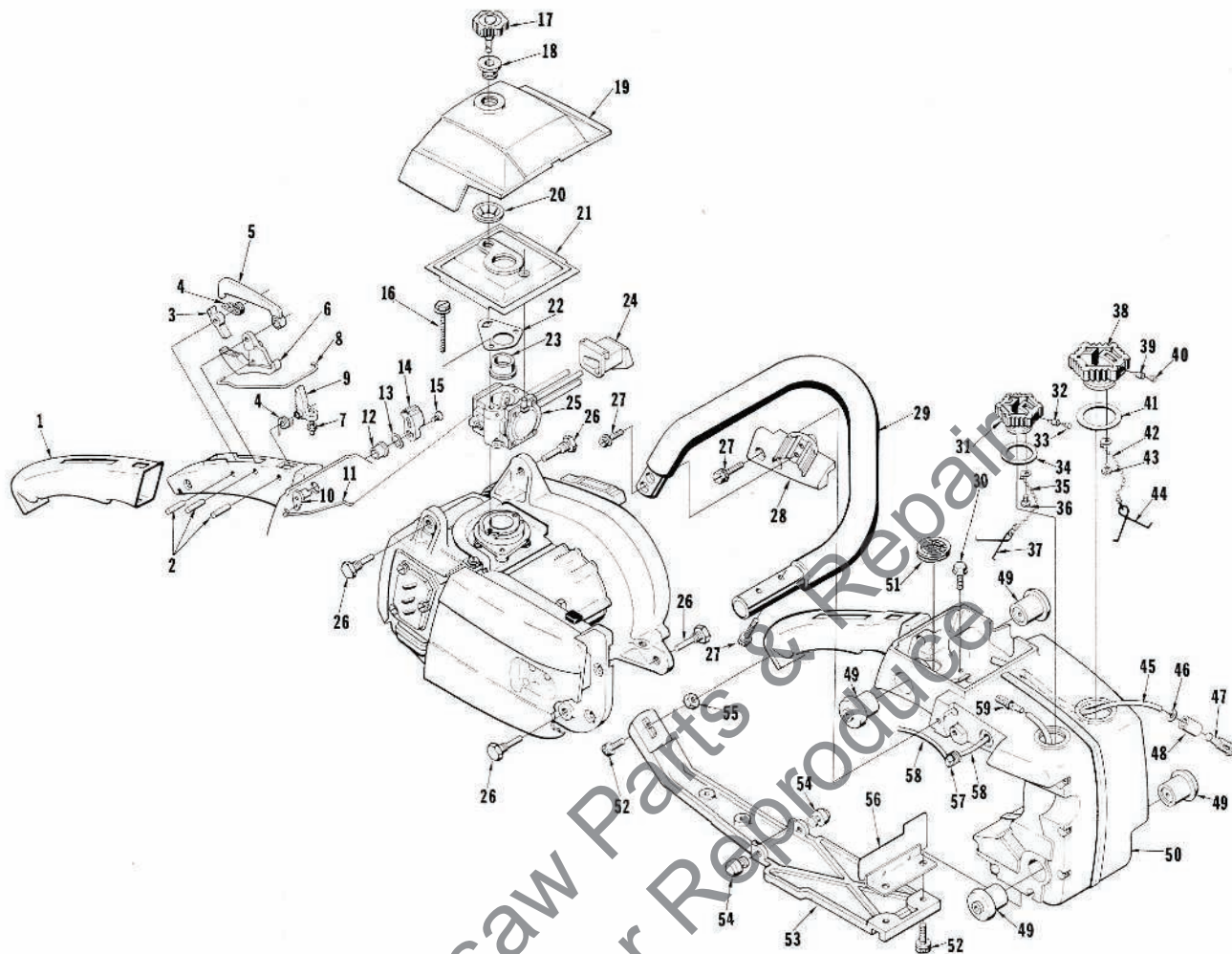

FIGURE 2

No.	Description	Part No.	Qty.	No.	Description	Part No.	Qty.
1	GRIP - throttle handle	12049	1	31	CAP - oil filler	A-12222	1
2	PIN - dowel	71173	3		Includes:		
3	LEVER - trigger lock	12092	1	32	VALVE - check (oval duckbill)	69451	1
4	SPRING - torsion	12051	2	33	FILTER - filler cap	69454	1
5	LOCK - trigger	12093	1	34	GASKET - oil cap	12126	1
* 6	KIT - trigger and screw	A-12966	1	35	CHAIN - bead	69502	1
* 7	Includes: SCREW - trigger latch	12094-1A	1	36	SCREW - pan hd Plastite 6 x 1/4	82256	1
8	ROD - throttle	12078-1	1	37	RETAINER	69503	1
* 9	LATCH - trigger	12091-1A	1	38	CAP - fuel filler	A-69500	1
10	SHAFT - choke	A-12227	1		Includes:		
* 11	ROD - choke	12149-A	1	39	VALVE - check (oval duckbill)	69451	1
12	BUSHING	12147	1	40	FILTER - filler cap	69454	1
13	WASHER - wave	12150	1	41	GASKET - fuel cap	69501	1
14	KNOB - choke	12145	1	42	CHAIN - bead	69502	1
15	SCREW - 8-32 x 3/8	88026	1	43	SCREW - pan hd Plastite 6 x 1/4	82256	1
16	SCREW - hex hd w/washer 10-24 x 1 3/4	88025	2	44	RETAINER	69503	1
17	NUT - filter cover mounting	A-12112	1	* 45	LINE - fuel	12973	1
18	BUSHING - nylon	12110	1	46	WASHER	64182	1
19	COVER - air filter	12033-3	1	47	PICK - UP - fuel	A-63920	1
20	NUT - push-on spring	12140	1	48	Includes: FILTER - felt	64083-1	1
21	FILTER ELEMENT - air	A-12225	1	49	ISOLATOR - vibration	12285	4
22	PLATE - spring	12117-1	1	50	HOUSING - engine	A-12286	1
23	BUSHING - flange	12109-1	1	51	Includes: SCREEN - air inlet (see note)	12269	1
24	GROMMET - "III - LOW"	12054	1	52	SCREW - hex hd w/washer 10-24 x 3/4	88022	3
* 25	CARBURETOR - HDC21 (350)	A-12977	1	53	BRACE - handle	12042-2	1
	CARBURETOR - HDC16 (350 HG, 350 SL)	A-12160	1	54	BUMPER	12096	2
26	PIN - isolator	12100	4	55	NUT - hex 10-24	81208	1
27	SCREW - hex hd w/washer 10-24 x 3/4	88022	6	56	DEFLECTOR - air (exhaust)	A-12153	1
28	BRACKET - handle bar	12059-2	1	57	FITTING - oil line	12135	1
29	HANDLE BAR	A-12107	1	* 58	LINE - oil	12165-A	2
30	SCREW - hex hd w/washer 10-24 x 5/16	88020	2	59	FINDER - oil	A-65172	1

\* Denotes new parts

Note: Remove Screen, index #51 when using Heat Exchanger.

# 350 · 350HG · 350 SL automatic saws

MUST BE TOWARD CRANKCASE

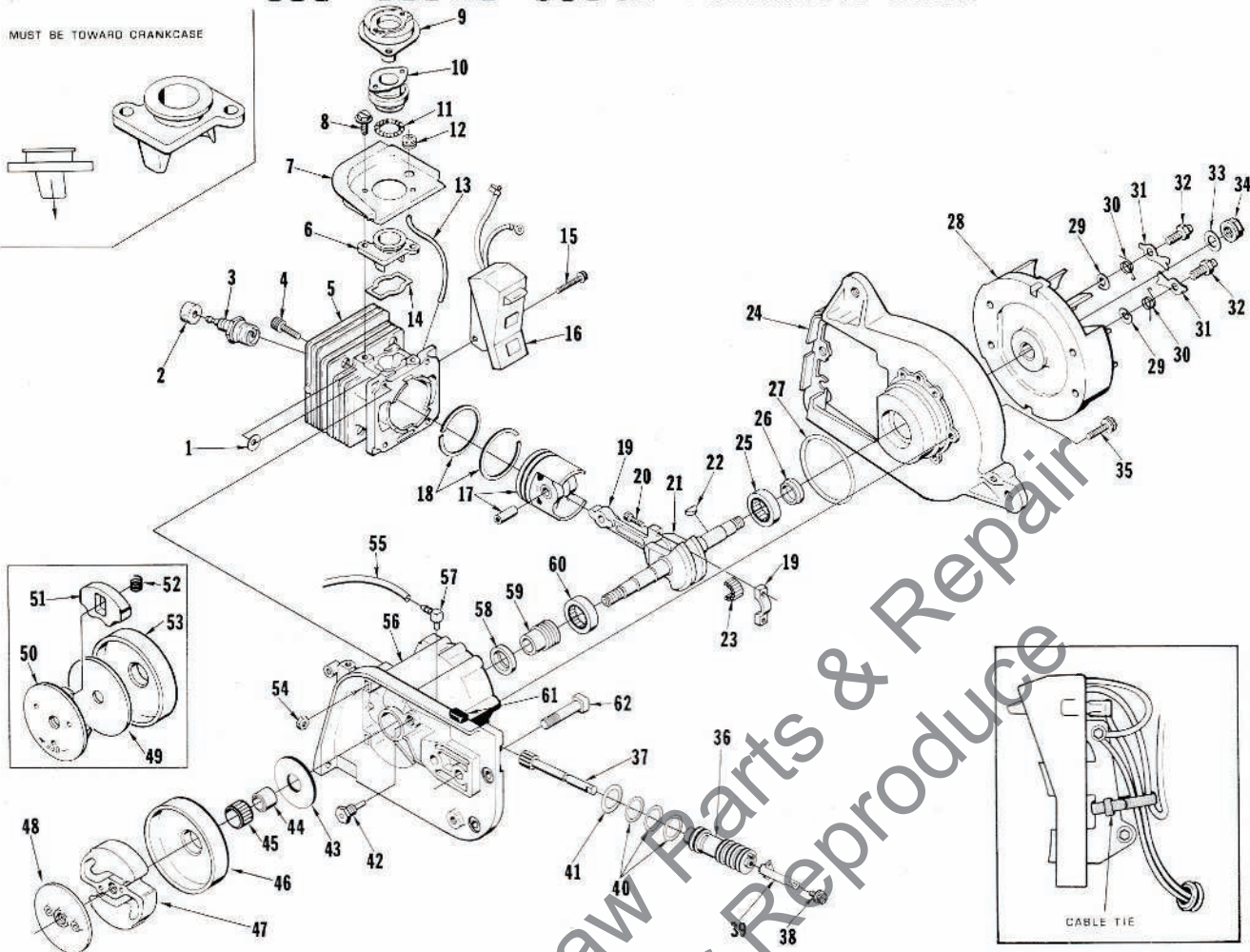
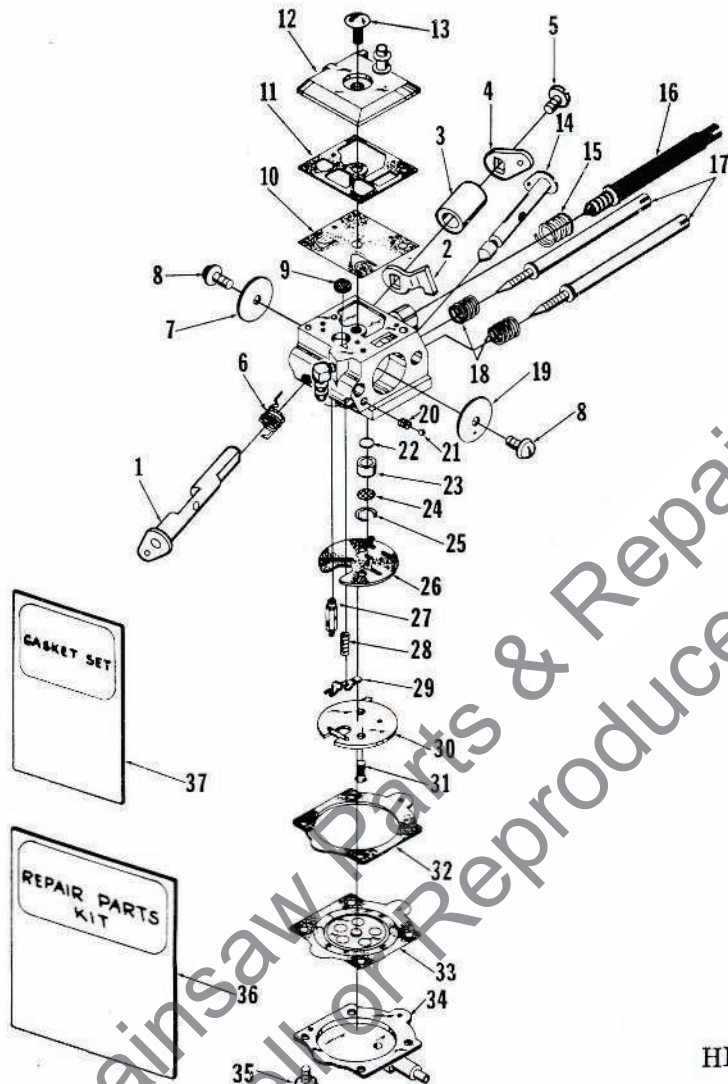

FIGURE 3

No.	Description	Part No.	Qty.	No.	Description	Part No.	Qty.
1	WASHER	12021	4	33	WASHER - 3/8	84099	1
2	GROMMET - spark plug	12191	1	34	NUT - 3/8 -24	81233	1
3	SPARK PLUG	65130-S	1	35	SCREW - hex hd w/washer 10-24 x 3/4	88022	5
4	SCREW - soc. hd, cap 10-24 x 7/8	82262	4	36	PUMP - automatic oiler	A-12201	1
5	CYLINDER	A-12245	1		Includes:		
	Includes: FITTING - not shown	69833	1	37	PLUNGER - oil pump	A-12202	1
6	MANIFOLD - intake	12046	1	38	SCREW - hex hd w/washer 8-32 x 3/8	88026	1
* 7	DEFLECTOR - air (intake)	12181-1A	1	39	LEVER - oil adjustment	12141	1
8	SCREW - hex hd w/washer 10-24 x 1/2	88024	2	40	"O" RING	12095	3
9	FLANGE - carburetor connector	12062-1	1	41	"O" RING	12155	1
* 10	CONNECTOR - carburetor	12048-A	1	42	PIN & PLUG	A-12144	1
11	SPRING - garter	12291	1	43	WASHER - thrust	63360	1
12	GROMMET	62740	1	44	RACE - inner	65985-A	1
* 13	LINE - pulse	12254-A	1	45	BEARING - needle	64124	1
14	GASKET - intake adapter	12047	1	46	SPROCKET & DRUM - 3/8", 7T (see note)	A-12294-1	1
15	SCREW - hex hd w/washer 8-32 x 1-1/4	82194	2	* 47	CLUTCH - "S"	(see note) 63362-4	1
16	MODULE & CORE	12669	1	48	PLATE - clutch	(see note) 12154	1
17	PISTON & PIN	A-12257-A	1	49	COVER - clutch	(see note) 63671	1
18	Includes: PISTON RING	12040	2		CLUTCH ASSEMBLY	(see note) A-69459	1
19	ROD - connecting	A-12068-1	1	50	Includes: PLATE - clutch	(see note) 65760-2	1
20	Includes: SCREW - soc. hd, 8-32 x 9/16	80805	2	51	SHOE - clutch	(see note) 69458	3
21	CRANKSHAFT	12037-1	1	52	SPRING - clutch	(see note) 63977	3
22	KEY - woodruff	75078	1	53	SPROCKET & DRUM - 3/8", 7T (see note)	A-69465	1
* 23	ROLLERS - needle (set of 25)	A-12913	1	54	NUT - centerlock #10-24	81208	4
24	PLATE - back	A-12204	1	* 55	LINE - oil	12165-A	1
25	Includes: BEARING - roller	63867	1	56	CRANKCASE	A-12251	1
* 26	SEAL	12282-A	1	57	Includes: FITTING - oil line	50558	1
27	"O" RING	58785	1	* 58	SEAL	12282-A	1
28	ROTOR	12101	1	59	WORM - gear	12071	1
29	WASHER - lock #10	83046	2	60	BEARING - roller	63867	1
30	SPRING - starter pawl	12055	2	* 61	BUMPER	12292	1
31	PAWL - starter	12056	2	62	BOLT - guide bar	58753	2
32	STUD - starter pawl	65109	2		CABLE TIE - module leads	12298	1

\* Denotes new parts

Note: Units with Shoe Clutch use index numbers 49 thru 53 and units with "S" Clutch Use Index Numbers 46, 47, and 48.



\*A-12977  
HDC 21 (350)

A-12160  
HDC 16 (350 HG, 350SL)

No.	Description	Part No.	Qty.	No.	Description	Part No.	Qty.
*	KIT - throttle shaft	A-12961	1	* 26	GASKET - circuit	‡ 67367-A	1
	Includes:			27	NEEDLE - inlet	† 64229	1
* 1	SHAFT - throttle	12945	1	28	SPRING - metering lever	† 12249	1
* 2	STOP - throttle	12943	1	29	LEVER - metering	† 67383	1
* 3	SPACER - throttle	12944	1	30	PLATE - circuit (HDC-16)	12277	1
* 4	LEVER - throttle	12942	1	*	PLATE - circuit (HDC-21)	12976	1
5	SCREW - valve	67372	1	31	SCREW - circuit plate	67375	2
6	SPRING - throttle return	† 67376	1	32	GASKET -metering diaphragm	‡ 64231	1
7	VALVE - throttle	12289	1	33	DIA PHRAGM - metering	† 67371	1
8	SCREW - valve	† 67372	2	34	COVER - metering diaphragm	12250	1
9	SCREEN - fuel inlet	† 64243	1	35	SCREW - metering cover	64689	4
10	DIA PHRAGM - fuel pump	† 67370	1	* 36	REPAIR KIT	12279-A	1
11	GASKET - fuel pump	‡ 67368	1	* 37	GASKET SET	† 67369-A	1
12	COVER - fuel pump	12196	1	*	KIT - high altitude (accessory)	A-12958	1
13	SCREW - pump cover	67374	1		Includes: PLATE - circuit	67382	1
14	SHAFT - choke	68632	1	*	GASKET - circuit	67367-A	1
15	SPRING - idle adjustment	12199	1	*	LABEL	12959	1
16	SCREW - idle adjustment	12197	1				
17	NEEDLE - idle adjustment	† 12198	2				
18	SPRING - needle adjustment	† 67377	2				
19	VALVE - choke	67365	1				
20	SPRING - choke friction	† 64238	1				
21	BALL - choke friction	† 60051	1				
	REPAIR KIT - check valve (accessory)	65386	1				
22	Includes: VALVE - check	_____	1				
23	SEAT - valve	_____	1				
24	SCREEN - check valve	67381	1				
25	RING - screen retaining	67360	1				

† Indicates contents of Repair Kit 12279-A

‡ Indicates contents of Gasket Set

\* Denotes new parts

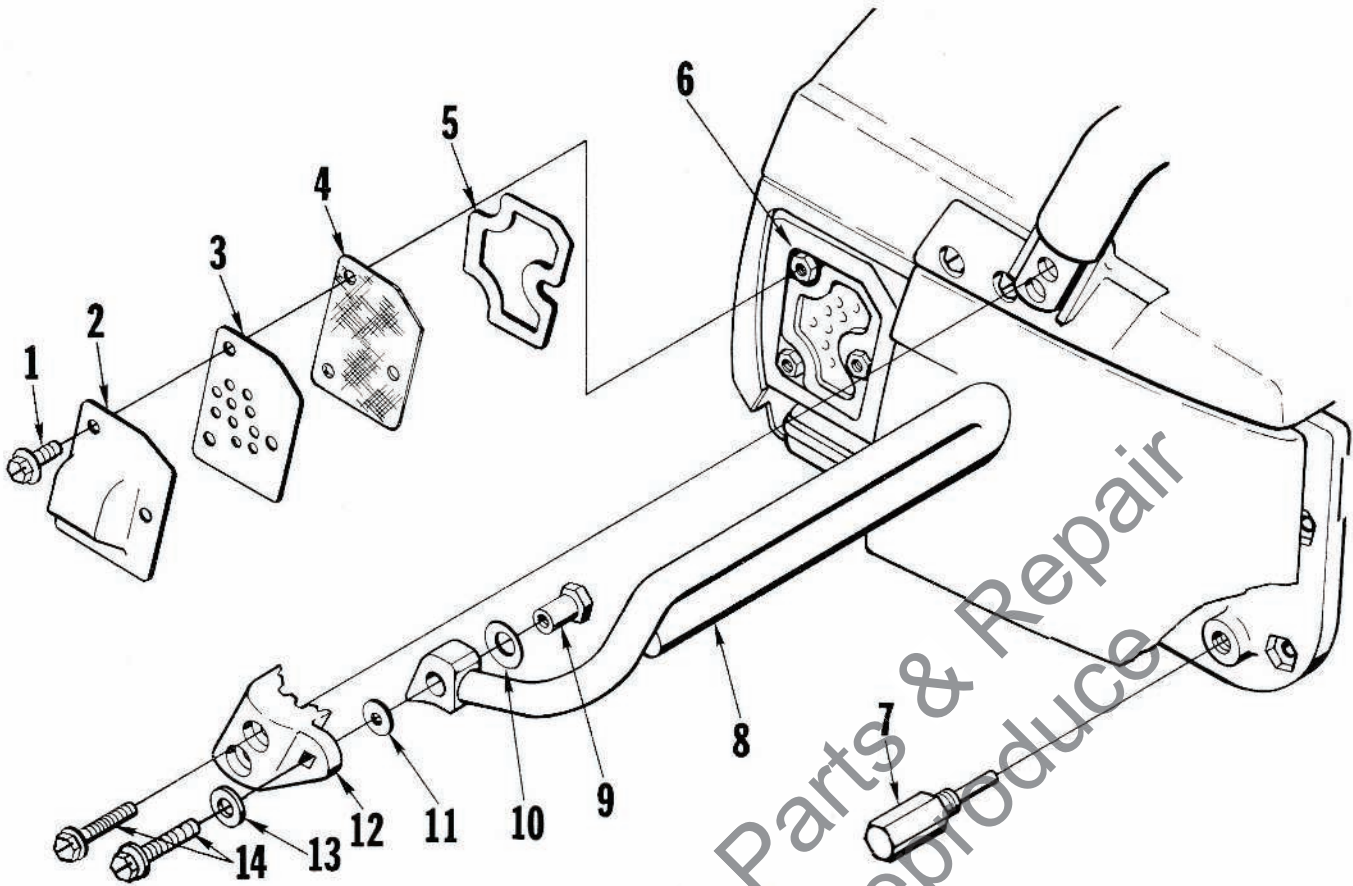

FIGURE 4

No.	Description	Part No.	Qty.	No.	Description	Part No.	Qty.
1	SCREW-8-32 x 3/8	88026	3	8	KIT-hand guard	A-12258	1
2	PLATE-muffler exhaust	12795-1	1	8	Includes: GUARD- hand	A-12243-1	1
3	BAFFLE	12719	1	9	SPACER-nut	12240	1
4	ARRESTOR-spark (accessory)	12270	1	10	WASHER-cupped spring	12239	1
5	GASKET-exhaust plate	12173	1	11	WASHER	58851-2	1
6	MUFFLER	A-12265	1	12	BRACKET-hand guard	12238-1	1
	Includes:			13	WASHER	12296	1
	GASKET-muffler (shown on Fig. 1)	12080	1	14	SCREW-hex hd. w/washer		
7	PIN-isolator (crankcase to fuel tank)	12268	1			10-24 x 1-1/4	88023
							3

FOR ALL UNITS

ACCESSORIES

ARRESTOR-spark	12270
*BUMPER-spiked	A-12272-A
*FILTER ELEMENT-air	A-69824
KIT-Chain Brake	A-12237
KIT-Hand Guard	A-12258
*LINE-fuel and oil (10 feet)	12974
ROPE-starting #4, 250 ft. reel	68848

PAINT

SPRAY CAN-black	22772
SPRAY CAN-red	23475

\* Denotes new parts

TOOLS

ANVIL-bearing removal (crankcase)	23846-1
ANVIL-bearing removal (crankcase & backplate)	23846-2
KEY-hex	22126
KEY-hex (HG-SL)	23528
PLUG-bearing & seal installation & removal	24827-A
PLUG-seal installation	24826-A
PULLER-rotor	A-24290
*SHIM-yellow plastic (.020)	24853
SLEEVE-seal assembly (crankcase & backplate)	23759
SLEEVE-seal removal (crankcase)	23136-6
TOOL & PLUNGER-piston pin	A-24871
WRENCH-combination	A-24824
WRENCH-spanner ("S" clutch)	A-23696-A
WRENCH-spanner (spider clutch)	A-23934

Refer to tool sheet #24873 for complete tool information.

350 SL automatic saws only

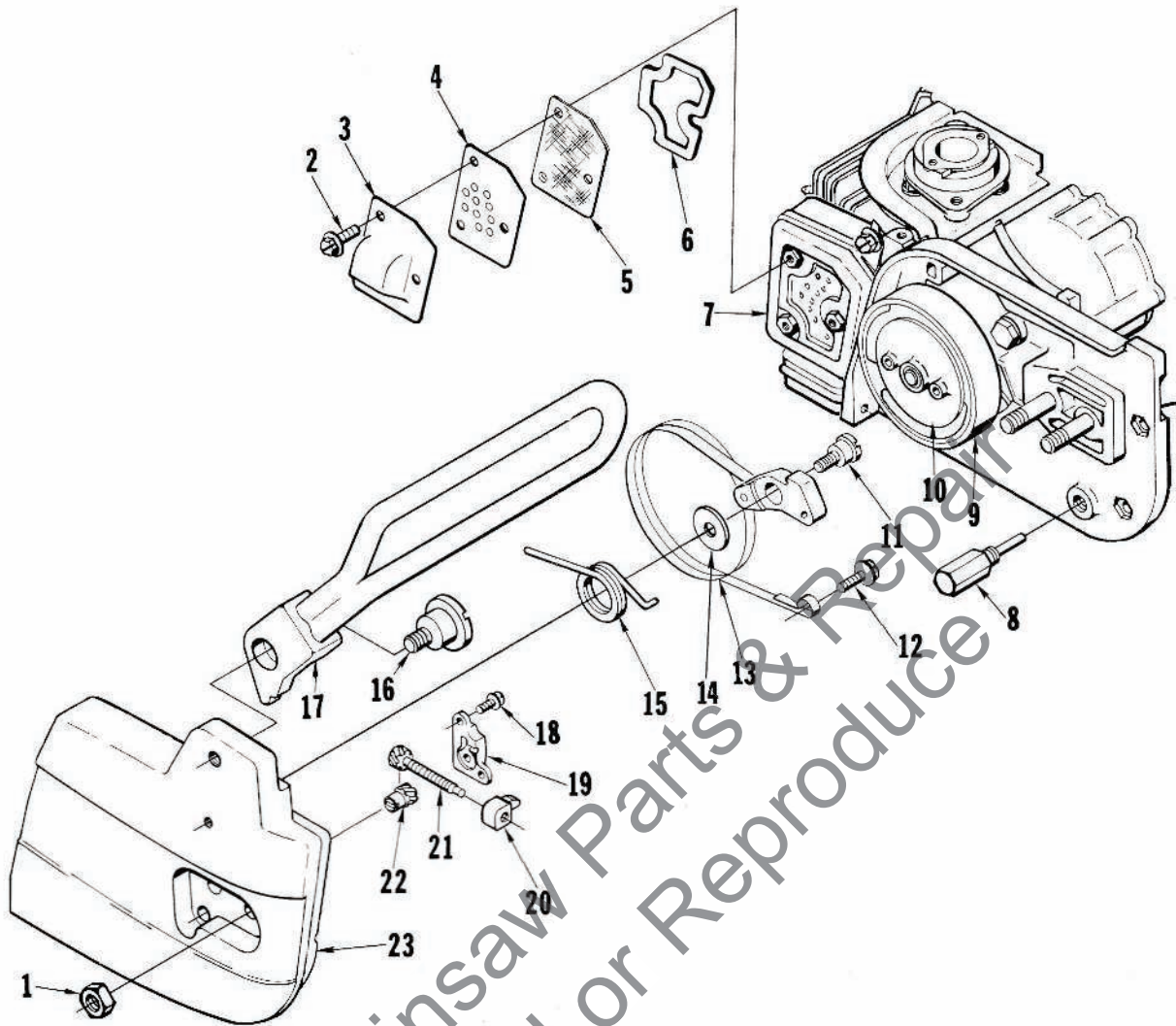

FIGURE 5

No.	Description	Part No.	Qty.
1	NUT-hex. 5/16-18	81196	2
2	SCREW-hex. hd. w/washer, 8-32 x 3/8	88026	3
3	PLATE-muffler exhaust	12195-1	1
4	BATFLE	12119	1
5	ARRESTOR-spark (accessory)	12270	1
6	GASKET-exhaust plate	12173	1
7	MUFFLER	A-12265	1
	Includes:		
	GASKET-muffler (shown on fig. 1)	12080	1
8	PIN-isolator (crankcase to fuel tank)	12268	1
	KIT-Chain Brake	A-12237	1
	Includes:		
9	SPROCKET & DRUM- 3/8", 7T	A-12294-1	1
*	CLUTCH- "S" (not shown)	68362-4	1
10	PLATE-clutch	12154	1
11	SCREW-shoulder	12371-1	1
12	SCREW-pan hd., 1/4-20 x 5/8	82258	1
13	BRAKE BAND & LEVER	A-12157	1
14	WASHER-spring retaining	12290	1
15	SPRING-torsion	69553	1
16	SCREW-shoulder (brake lever)	12379-1	1
17	LEVER-brake w/guard	A-12156	1
18	SCREW-pan washer hd., 6-32 x 3/8	82251	2
19	COVER-gear	12134	1
20	PIN-guide bar adjusting	12133-1	1
21	SCREW-guide bar adjusting	A-12132	1
22	ADJUSTER-guide bar	A-12137	1
23	COVER-drivccase	A-12297-1	1

\* Denotes new parts

Part No.	Description	Qty.	Part No.	Description	Qty.	Part No.	Description	Qty.	Part No.	Description	Qty.
12021	Washer	4	*12165-A	Line-oil	2	12791-A	Screw-Plastite	2	65985-A	Race-inner	1
12033-3	Cover-air filter	1	12173	Gasket-exhaust	1	12793-A	On-Off Plate	1	67360	Ring-screen	2
12037-1	Crankshaft	1	12176-1	Plate-exhaust	1	*A-12913	Rollers-needle	1	67365	Valve-choke	1
12040	Piston Ring	2	12191	Grommet	1	*12942	Lever-throttle	1	*67367-A	Gasket-circuit	1
12042-2	Brace-handle	1	12192	Decal-starter	1	*12943	Stop-throttle	1	67368	Gasket-fuel	1
12046	Manifold-intake	1	12195-1	Plate-muffler	1	*12944	Spacer-throttle	1	*67369-A	Gasket Set	1
12047	Gasket-intake	1	12196	Cover-fuel	1	*12945	Shaft-throttle	1	67370	Diaphragm-fuel	1
*12048-1	Connector	1	12197	Screw-idle	1	*A-12958	Kit-high altitude	1	67361	Diaphragm	1
12049	Grip-throttle	1	12198	Needle-idle	2	*12959	Label	1	67372	Screw-valve	2
12051	Spring-torsion	2	12199	Spring-needle	2	*A-12961	Kit-throttle shaft	1	67374	Screen-fuel	1
12052	Shield-spring	1	A-12201	Pump-auto.	1	*A-12966	Kit-trigger & screw	1	67375	Screw-circuit	2
12053	Bushing-starter	1	A-12202	Plunger	1	*12972	Rope-starter	1	67376	Spring-throttle	1
12054	Grommet	1	A-12204	Plate-back	1	*12973	Line-fuel	1	67377	Spring-idle	1
12055	Spring-starter	2	A-12214	Pulley & Cup	1	*12974	Line-fuel & oil	1	67381	Screen-check	2
12056	Pawl-starter	2	A-12222	Cap-oil filler	1	*12976	Plate-circuit	1	67382	Plate-circuit	1
12059-2	Bracket-handle	1	A-12225	Filter element	1	*A-12977	Carburetor	1	67383	Lever-metering	1
12062-1	Flange-carburetor	1	A-12227	Shaft-choke	1	22126	Key-hex	1	68279	Grommet	1
A-12068-1	Connecting Rod	1	A-12237	Kit-chain brake	2	22772	Paint-black	1	*68362-4	Clutch-S	1
12071	Worm	1	12238-1	Bracket-hand	1	23136-6	Sleeve-seal	1	A-68465	Drum & Sprocket	1
12074-2	Shield-cylinder	1	12239	Washer-cupped	1	23475	Paint-red	1	68632	Shaft-choke	1
12078-1	Rod-throttle	1	12240	Spacer-nut	1	23528	Key-hex	1	68837	Insert-ropo	1
*12080-A	Gasket-muffler	1	A-12243-1	Guard-kickback	1	A-23696-A	Wrench-spanner	1	68848	Rope-starting	1
12089	Shield-pulley	1	A-12248	Cylinder	1	23759	Sleeve	1	69451	Valve-check	2
*12091-1A	Latch-trigger	1	12249	Spring-metering	1	23846-1	Anvil	1	69454	Filter-filler	2
12092	Lever-trigger	1	12250	Cover-metering	1	23846-2	Anvil	1	69458	Shoe-clutch	3
12093	Lock-trigger	1	A-12251	Crankcase	1	A-23934	Wrench-spanner	1	A-69459	Clutch-"S"	1
12095	"O" Ring	3	12253	Exchanger-heat	1	A-24290	Puller-rotor	1	A-69500	Cap-fuel filler	1
*12094-1A	Screw-trigger	1	*12254-A	Line-pulse	1	A-24824	Wrench	1	69501	Gasket-fuel cap	1
12096	Bumper	2	A-12257-A	Piston & Pin	1	24826-A	Plug-seal	1	69502	Chain-bead	2
12100	Pin-isolator	4	A-12258	Kit-Hand Guard	1	24827-A	Plug-bearing	1	69503	Retainer	2
12101	Rotor	1	A-12265	Muffler	1	*24853	Shim-yellow	1	69553	Spring-torsion	1
A-12107	Handle Bar	1	12268	Pin-isolator	2	*A-24871	Tool & plunger	1	69656	Line-fuel & oil	1
12109-1	Bushing-flange	1	12269	Screen-air inlet	1	50558	Fitting-oil line	1	*A-69824	Filter-element	1
12110	Bushing-nylon	1	12270	Arrestor-spark	1	A-57650-3	Switch-grounding	1	69833	Fitting	1
A-12112	Nut-filter cover	1	*A-12272-A	Bumper-spiked	1	58753	Bolt-guide bar	2	71478	Nut-dowel	3
12117	Plate-spring	1	12277	Plate-circuit	1	58785	"O" Ring	1	72084-A1	Pin	1
12119	Baffle	1	*12279-A	Repair Kit	1	58857-2	Washer	1	75078	Key-Woodruff	1
12126	Gasket-oil cap	1	*12282-A	Seal	2	60051	Ball-choke	1	FASTENING PARTS		
A-12132	Screw-guide bar	3	12283	Plug-cylinder	1	62740	Grommet	1	80805	8-32 x 9/16	2
12133-1	Pin-guide bar	2	12285	Isolator	1	63671	Cover-clutch	1	81196	Nut-5/16-18	4
12134	Cover-gear	1	A-12286	Housing-engine	1	63860	Washer-thrust	1	81208	Nut-10-24	5
12135	Fitting-oil line	1	12289	Valve-throttle	1	63867	Bearing-roller	2	81233	Nut-3/8-24	1
A-12137	Adjuster-guide bar	2	12290	Washer-retainer	1	A-63920	Pick-up fuel	1	82194	8-32 x 1-1/4	2
12140	Nut-push on spring	1	12291	Spring-garter	1	63977	Spring-clutch	3	82215	6 x 3/8	2
12141	Lever-oil	1	*12292	Bumper	1	64083-1	Filter-felt	1	82251	6-32 x 3/8	4
A-12144	Pin & Plug	1	A-12294-1	Sprocket & Drum	1	64124	Bearing-needle	1	82256	6 x 1/4	2
12145	Knob-choke	1	A-12295-1	Cover-drivecase	1	64155-A	Grip-starting rope	1	*82258	1/4-20 x 5/8	1
12147	Bushing	1	12296	Washer	1	64182	Washer	1	82262	10-24 x 7/8	4
*12149-A	Rod-choke	1	A-12297-1	Cover-drivecase	1	64229	Needle-inlet	1	83046	Washer-#10	2
12150	Washer-wave	1	12298	Cable-tie	1	64231	Gasket-metering	1	84099	Washer-3/8	1
A-12153	Deflector-air	1	A-12299	Transformer	1	64238	Spring-choke	1	88020	10-24 x 5/16	4
12154	Plate-clutch	1	12371-1	Screw-shoulder	1	64243	Screen-fuel inlet	1	88022	10-24 x 3/4	18
12155	"O" Ring	1	12379-1	Screw-shoulder	1	64689	Screw-metering	4	88023	10-24 x 1-1/4	4
A-12156	Lever-brake	1	12523	Cover-starter	1	65102	Lock-spring	1	88024	10-24 x 1/2	4
A-12157	Brake Band & Lever	1	12629	Receptacle	1	65107	Spring-rewind	1	88025	10-24 x 1-3/4	2
A-12160	Carburetor	1	12669	Module & Core	1	65109	Stud-starter	2	88026	8-32 x 3/8	11
*12161-1A	Deflector-air	1	A-12718	Lead-ground	1	65130-S	Spark Plug	1	88027	8-32 x 1/2	2
12162	Plate-guide bar	1	A-12719	Lead-module	1	A-65172	Finder-oil	1	88031	10-24 x 3/8	2
12163	Plate-guide bar	1	12788	Contact	2	65185	Bushing-ropo	1			
						65386	Repair Kit	1			
						65760-2	Plate-clutch	1			

\* Denotes new parts

**HOMELITE®**

A Textron  
DIVISION

PORT CHESTER, NEW YORK, U.S.A. 10573

E2647 DBZ