

PART NO. 17505 REV. 3

Printed in U.S.A.

Price 35¢

HOMELITE®

330 CHAIN SAWS

PARTS LIST

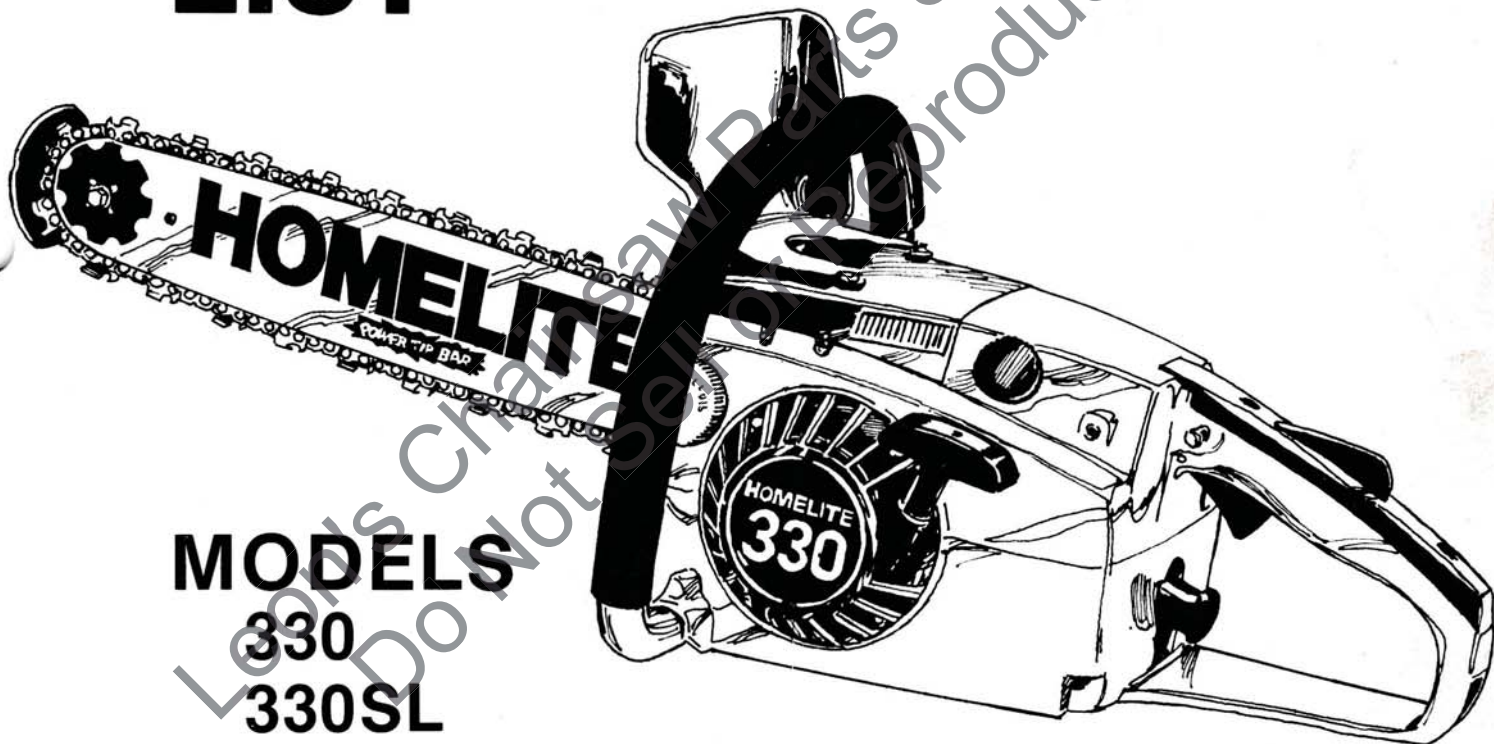

MODELS

330

330SL

330W

330 WINTER UNIT

HOMELITE **TEXTRON**

Homelite Division of Textron Inc.

330 CHAIN SAW

FIGURE 1

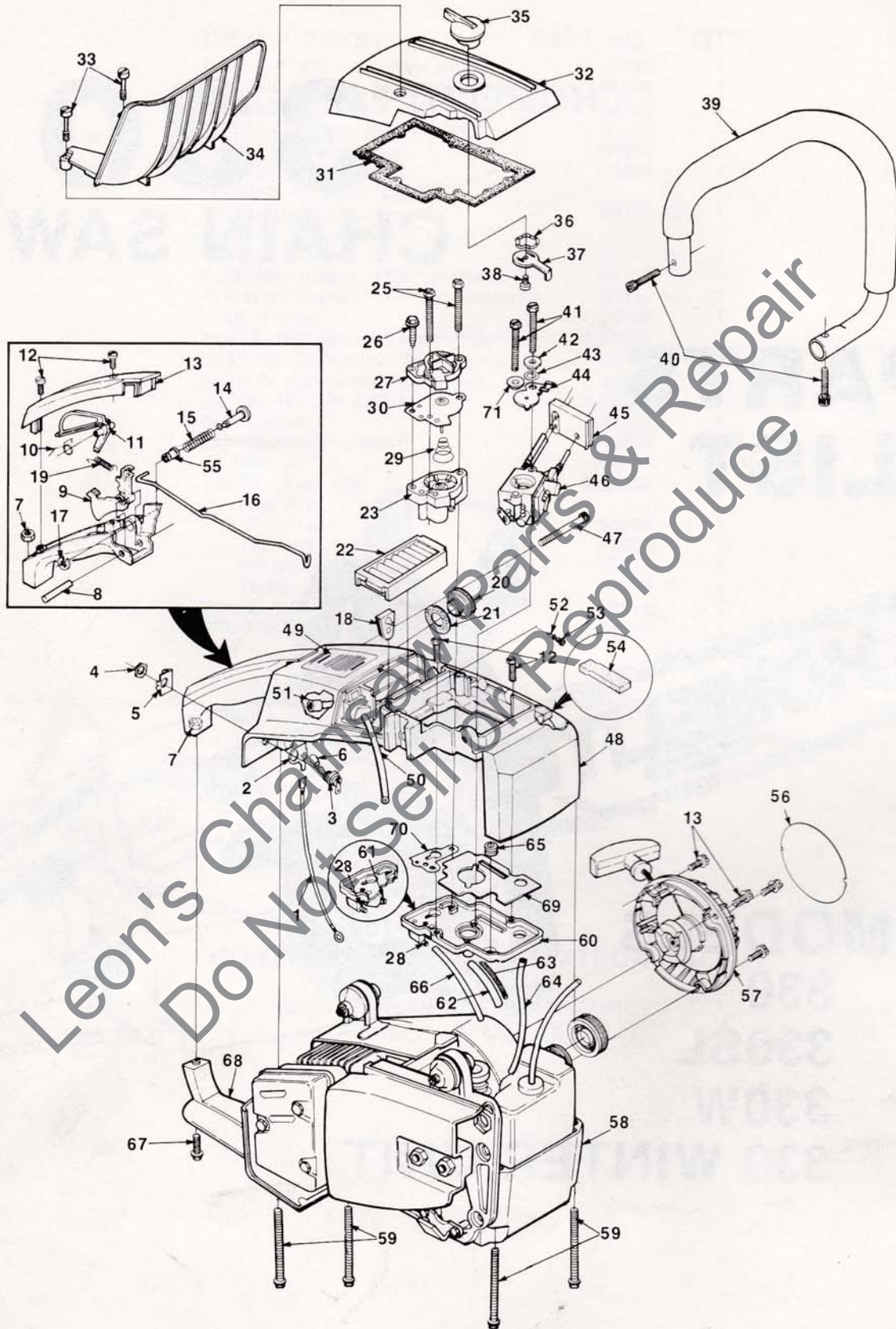

330 CHAIN SAW

FIGURE 1

NO.	DESCRIPTION	PART NO.	QTY.	NO.	DESCRIPTION	PART NO.	QTY.
1	LEAD- Electrical	A-95933-A	1	41	SCREW- Mach. hex. hd. (10-32 x 1 7/8)	82179	2
2	CONTACT- Ground	95874	1	42	SPACER- Choke	94504	1
3	SWITCH- Grounding Includes:	A-57650-3A	1	43	WASHER- Wave	94382	1
4	NUT- Switch	72084-A1	1	44	PLATE- Choke	94503-A	1
5	PLATE- Ignition (Run-Stop)	12793-A	1	45	GROMMET	94381	1
6	SLEEVE- Grounding switch	69092	1	46	CARBURETOR (Walbro WT-4) (Alternate source)	A-94380-A	1
7	NUT- Locking hex (10-24)	81208	1		CARBURETOR (Zama C-15-H3) (Primary source)	A-96421	1
8	PIN- Groove	93517	1	47	SCREW- Cap socket hd. (10-24 x 1 3/4)	82377	1
9	TRIGGER- Throttle	93842	1	48	HOUSING- Engine Includes:	A-96419-A	1
10	SPRING- Torsional	94379	1	49	DECAL	95633	1
11	THROTTLE- Interlock	93843	1	50	TUBING (after Lot #C309)	70309-26	1
12	SCREW- Hex hd. (8-32 x 1/2)	80983	8	51	FINDER- Oil	A-68593	1
13	HANDLE- Cover	93822	1	52	VALVE- Duck bill	96841	1
14	PIN- Throttle lock (prior to lot #C309)	94378	1	53	FILTER	69454	1
15	SPRING- Compression	95020	1	54	FILTER- Fuel tank valve	69443	1
16	ROD- Throttle	94377-A	1		PIN- Throttle lock (after Lot #C309)	95671	1
17	RING- Retaining	58409	1	55	SPRING- Compression	95020	1
18	GROMMET	94376	1		BUSHING- Flanged	95989	1
19	SPRING- Extension	95976-A	1		RING- Retaining	58409	1
20	CAP- Oil Includes:	A-95207	1	56	DECAL- Starter housing	94386	1
21	GASKET	94390	1	57	HOUSING- Starter	A-94736	1
22	FILTER ELEMENT- Air	94387-B	1	58	HOUSING- Engine (bottom)	93830-2	1
23	PUMP- Oil Includes:	A-95049	1	59	SCREW- Hex hd. (10-24 x 2.5000)	88060	4
25	SCREW- Hex hd. (8-32 x 2)	82224	2	60	PLATE- Carburetor chamber Includes:	A-94673	1
26	SCREW- Thd. forming (8-16 x 5/8)	82380	1		FITTING- Tube (L)	94392	1
27	COVER- Oil pump	94395	1	61	TUBING- 2" (pulse line)	95201-08	1
28	FITTING- Tube	94619	1	62	SPRING- Pulse line (inside)	95216	1
29	SPRING- Helicoil	94634	1	63	TUBING- 5 1/4" (pulse line)	93157-21	1
30	DIAPHRAGM & PLUNGER	A-94675	1	64	GROMMET	64862	1
31	GASKET- Air filter cover	95921	1	65	TUBING- 3" (Oil Deliver)	93112-12	1
32	COVER- Air filter	95828	1		FITTING- Tube (see index #28)	94619	1
33	SCREW- Self retaining (330 only)	93678	2	67	SCREW- Sems hex hd. (10-24 x 3/4)	88051	1
	SCREW- Rd. hd. (10-24) (330SL only)	95792	2	68	BRACE- handle	94763	1
34	GUARD- Hand (330 only)	95027	1	69	GASKET- Carburetor	95342	1
35	BUTTON- Choke	94389	1	70	GASKET- Oil pump	94391	1
36	WASHER- Wave	94388	1		TUBING- 6 1/2" (Oil) (prior to Lot #C309)	93112-26	1
37	LEVER- Choke	94502	1	71	SPACER- Flanged	96894	1
38	SCREW- Pan taplrite (8-32 x 5/16)	95922	1				
39	HANDLE BAR- Flush cut (prior to Lot #C309)	A-93853	1				
	HANDLE BAR- Flush cut (After Lot #C309)	A-93853-1	1				
40	SCREW- Cap socket hd. (10-24 x 1)	82246	2				

330 CHAIN SAW

FIGURE 2

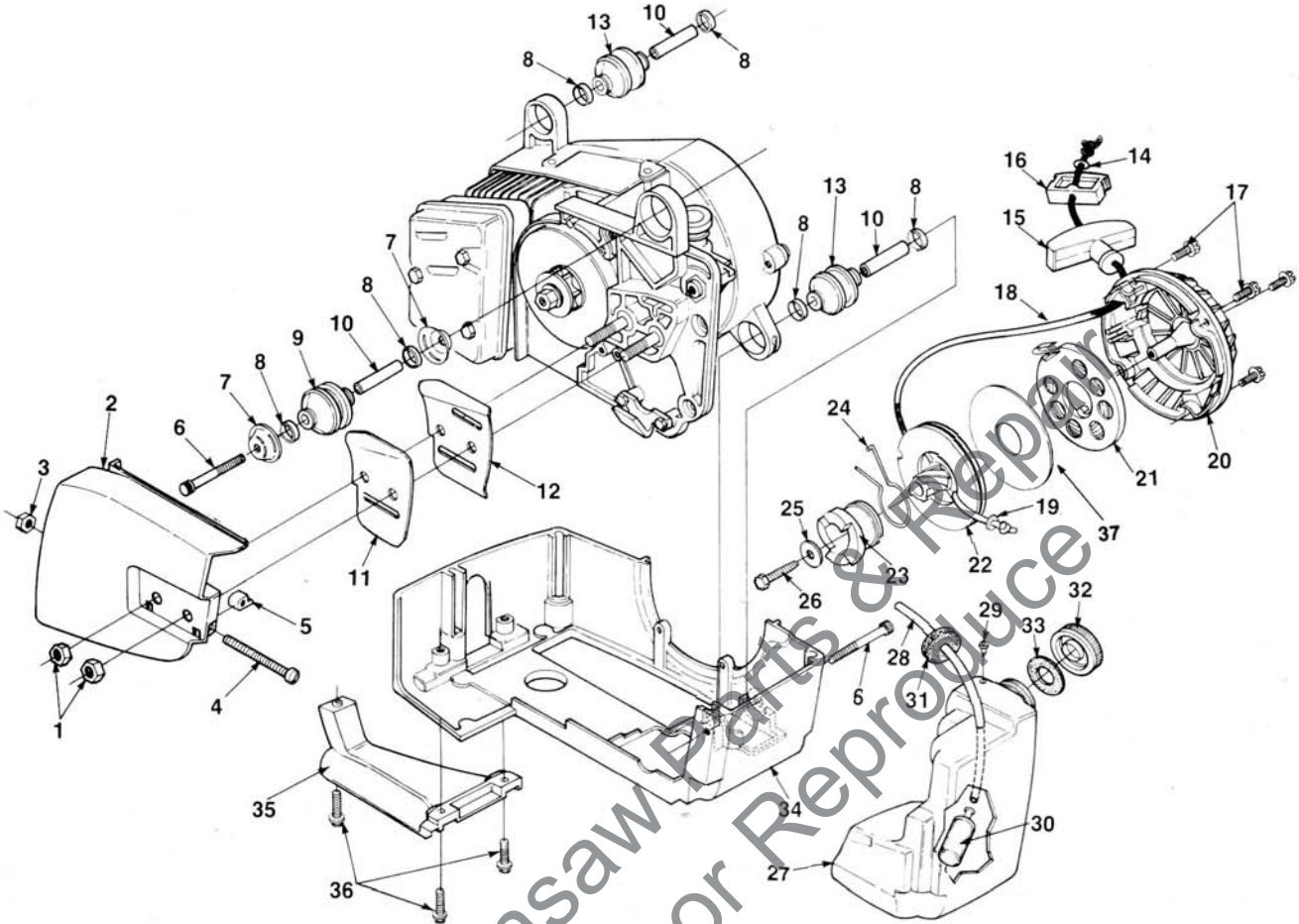

NO.	DESCRIPTION	PART NO.	QTY.	NO.	DESCRIPTION	PART NO.	QTY.
1	NUT- Hex (5/16-18)	81196	2	20	HOUSING- Starter	A-94736	1
2	COVER- Drivecase	A-94685-1	1	21	SPRING- Rewind w/retainer	A-94918-A	1
	Includes:			22	PULLEY- Starter	94383-A	1
3	NUT- Hex (10-32)	81206	1	23	RATCHET- Starter	94384	1
4	SCREW- Guide bar adjusting	65175-A	1	24	LEVER- Ratchet	94505-A	1
5	PIN- Guide bar adjusting	65112-1	1	25	WASHER	95208	1
6	SCREW- Cap socket hd. (10-24 x 1 3/4)	82377	2	26	SCREW- Thd. forming (#10 x 1 1/4)	82392	1
7	WASHER- Vibration isolator	70440-A	2	27	TANK- Fuel	A-94678-A	1
8	RING- Vibration isolator	70432-A	6		Includes:		
9	ISOLATOR- Vibration	95868	1	28	TUBING- 7 1/2" (fuel)	93112-30	1
10	SPACER	70433	3	29	VALVE- Check	96841	1
11	PLATE- Guide bar (outer)	95453	1	30	FILTER- Fuel	96639	1
12	PLATE- Guide bar (inner)	95452	1	31	SEAL- Foam	95206	1
13	ISOLATOR- Vibration	95915	2	32	CAP- Fuel	A-94671	1
14	WASHER- Flat (#8)	84025	1		Includes:		
15	GRIP- Starter	A-69962-B	1	33	GASKET- Filler cap	94390	1
	Includes:			34	HOUSING- Engine (bottom)	93830-2	1
16	INSERT- Rope	70018-A	1	35	BRACE- Handle	94763	1
17	SCREW- (8-32 x 1/2)	80983	4	36	SCREW- Sems hex hd. (10-24 x 3/4)	88051	3
18	ROPE- Starter	A-93876	1				
	Includes:			37	SHIELD	12320-A	1
19	WASHER- Nylon	93862	1				

330 CHAIN SAW

FIGURE 3

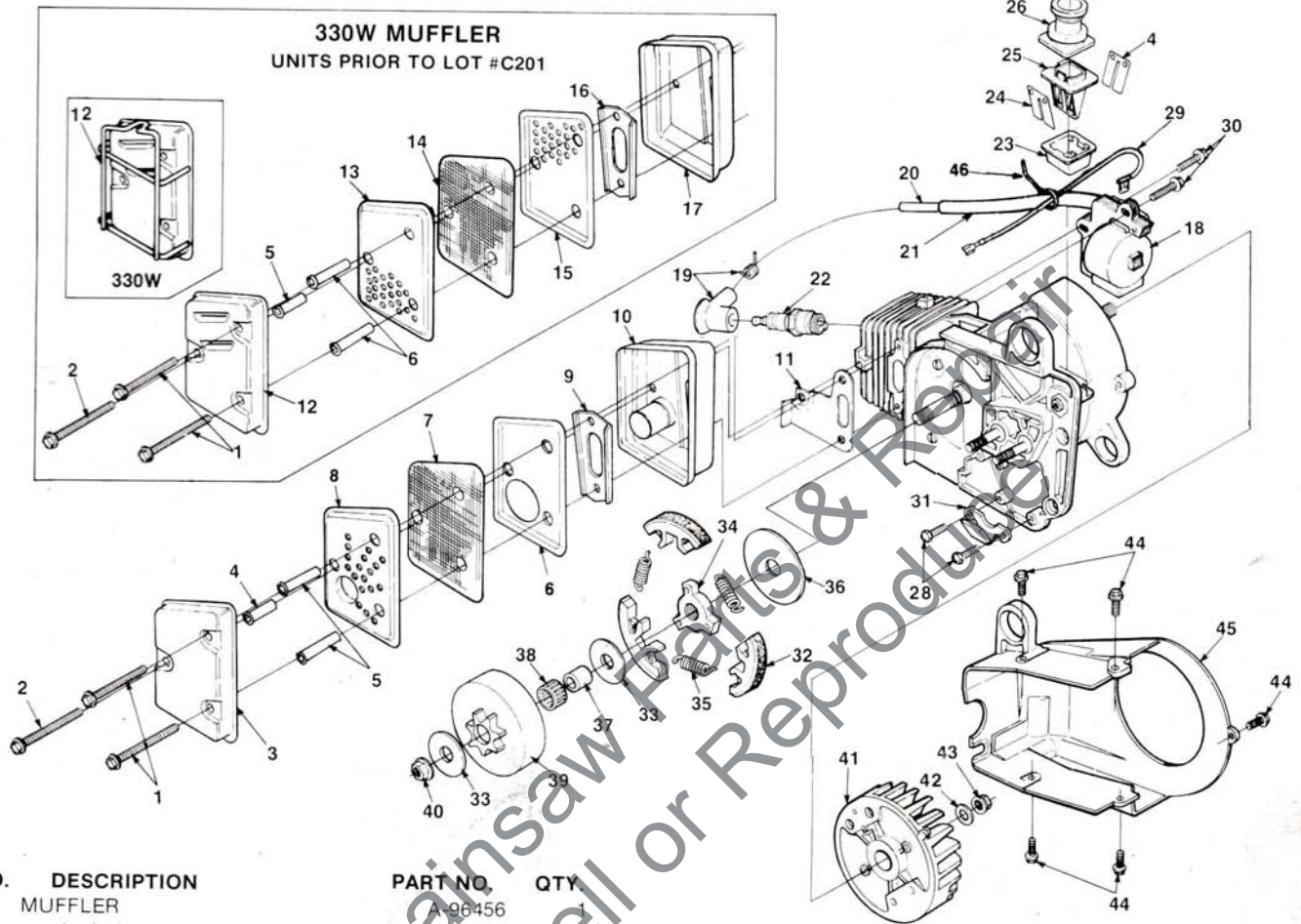

NO. DESCRIPTION
MUFFLER

PART NO. QTY.
A-96456 1

Includes:

NO.	DESCRIPTION	PART NO.	QTY.
1	SCREW- Hex hd (10-24 x 2 1/4)	88058	2
2	SCREW- Hex sems (10-24 x 2)	88057	1
3	CAP- Muffler	96090-1	1
4	SPACER- Muffler	93983-02	1
5	SPACER- Muffler	93983-04	1
6	BAFFLE- Muffler	96091	1
7	SCREEN- Spark arrestor	96094	1
8	BAFFLE- Muffler	96092	1
9	PLATE- Reinforcing	94501	1
10	BODY- Muffler	A-96815-1	1
11	DEFLECTOR- Exhaust	96093-A	1
12	CAP- Muffler (units prior to Lot #C201)	93856-1A	1
	CAP- Muffler (units prior to Lot #C201) (330W)	A-96069-1	1
13	BAFFLE- Muffler (outer) (prior to Lot #C201) (330W)	93855	1
14	SCREEN- Spark arrestor (330W) (prior to Lot #C201)	93504	1
15	BAFFLE- Muffler (330W) (prior to Lot #C201)	93515	1
16	PLATE- Reinforcing (prior to Lot #C201)	94501	1
17	BODY- Muffler (330W) (prior to Lot #C201)	93857-1	1
18	MODULE- Ignition	A-94361	1
	Includes:		
19	TERMINAL- High tension	A-94754	1

NO. DESCRIPTION

20	LEAD- high tension	94362	1
21	SLEEVE- Insulation	95098	1
22	SPARK PLUG	96169-S	1
23	RETAINER- Reed valve	93836-B	1
24	VALVE- Reed	93834-1	2
25	SEAT- Reed stop	93835-A	1
26	BOOT- Connector	93838-B	1
27	RETAINER- Boot	93847	1
28	SCREW- (8-32 x 1/2)	80983	4
29	LEAD- Electrical	A-94668-A	1
30	SCREW- (10-24 x .875)	88052	2
31	STOP- Chain	70705	1
32	SHOE- Clutch	A-93632-A	3
33	WASHER- Thrust	65064	2
34	SPIDER- Clutch	94374	1
35	SPRING- Clutch	93814-A	3
36	WASHER- Thrust	93643	1
37	RACE- Inner	65746-B	1
38	BEARING- Roller	64124	1
39	SPROCKET & DRUM- 3/8" pitch 7T	A-95621	1
40	NUT- Hex (3/8-24)	81236	1
41	ROTOR	93844-A	1
42	WASHER- Flat	95479-A	1
43	NUT- Lock (rotor,nut)	81255	1
44	SCREW- Hex sems (10-24 x .625)	88050	5
45	SHROUD- Air	94341-2	1
46	CABLE TIE	46840	1

ALWAYS FURNISH MODEL AND SERIAL NUMBER WHEN ORDERING PARTS.

330 CHAIN SAW

FIGURE 4

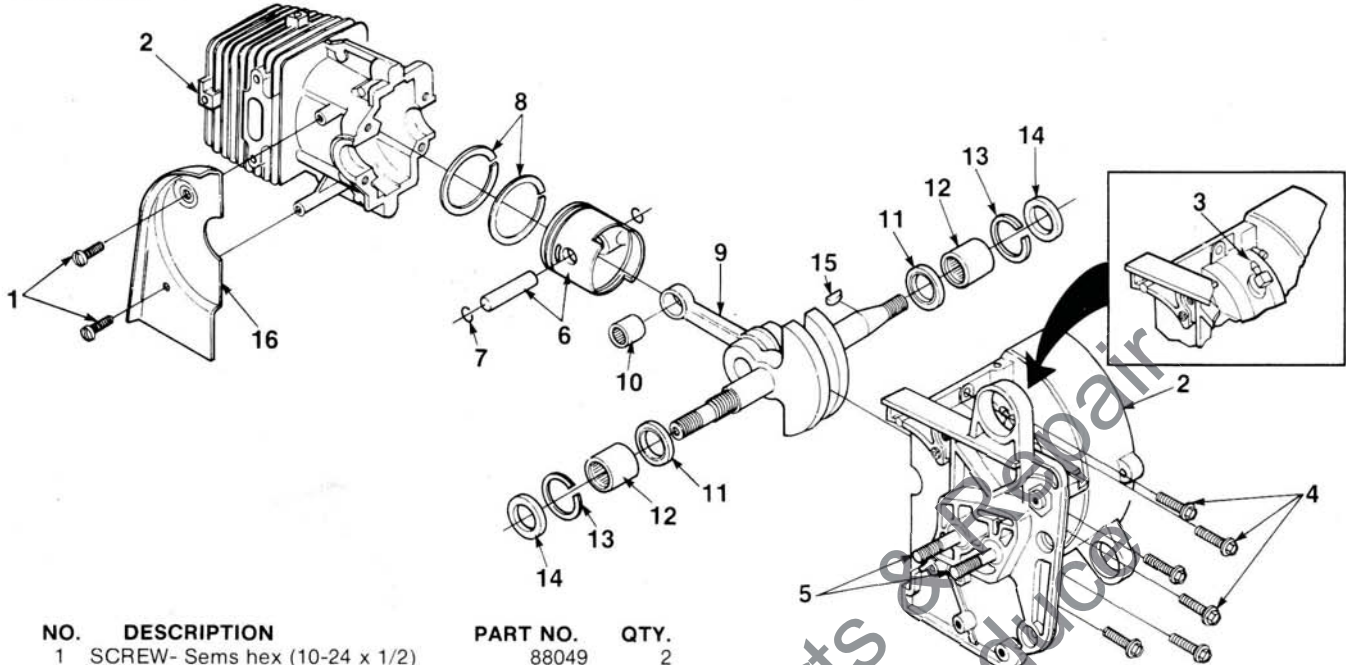

NO.	DESCRIPTION	PART NO.	QTY.
1	SCREW- Sems hex (10-24 x 1/2)	88049	2
2	CRANKCASE & CYLINDER	A-95884-A	1
Includes:			
3	FITTING- Tube	70204	1
4	SCREW- (10-24 x 1)	88053	6
5	BOLT- Guide bar	93859	2
	FITTING- Tube (L) not shown	94392	1
	FITTING- Tube (Not shown)	94619	1
6	PISTON	A-95882-A	1
Includes:			
7	RING- Retaining	64813	2
8	PISTON RING	96510	2

NO.	DESCRIPTION	PART NO.	QTY.
9	CRANKSHAFT	A-96418-B	1
Includes:			
10	BEARING- Rod	93369	1
11	WASHER- Thrust (see Note 1)	94860	2
12	BEARING- Needle	93846	2
13	RING- Retaining	93819	2
14	SEAL- Crankshaft	93858	2
15	KEY- Woodruff	75078	1
16	SHIELD- Sawdust	93832	1

330SL

FIGURE 5

CHAIN BRAKE AND CHAIN STOP

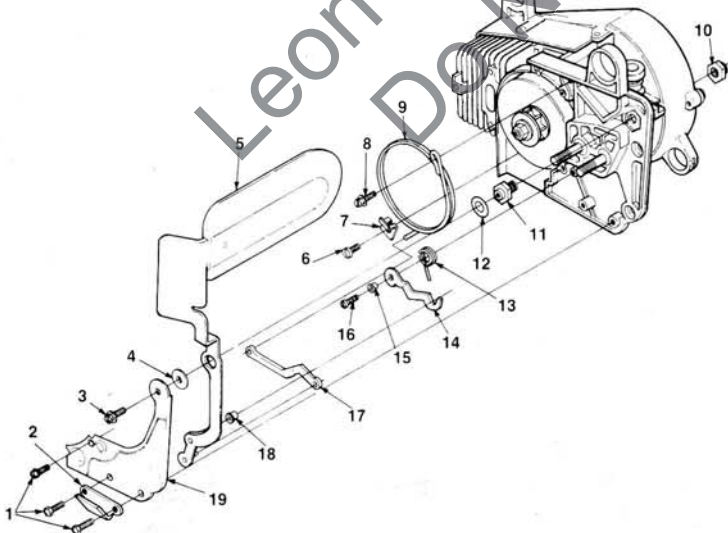

NO.	DESCRIPTION	PART NO.	QTY.
1	SCREW- (8-32 x 1/2)	80983	3
2	STOP- Chain	70705	1
3	SCREW- (10-24 x 3/8)	88048	1
4	WASHER- Flat	70632	1
5	GUARD- hand	A-95409-A	1
6	SCREW- Pan hd.	80672	1
7	BRACKET	95411	1
8	SCREW (12-24 x 1/2)	80821	1
9	BAND- Brake	95283	1
10	NUT- Hex (3/8-24)	81192	1
11	INSERT- Chain brake	95376	1
12	WASHER- Spring	95410	1
13	SPRING- Torsion	95284-A	1
14	DETENT- Brake lever	95287	1
15	SPACER- Flanged	95295	1
16	SCREW- Mach. pan. hd. (8-32 x 1/2)	82254	2
17	LINK- Chain brake	95286	1
18	BUSHING	95494	1
19	SHIELD- Chain brake	95394-1	1
	BUMPER- Spike (not shown)	95838	1
	CARBURETOR SHIELD (not shown)	96062-1	1

NOTE 1: Units prior to lot #D223 using A-96418 or A-96418-A crankshaft will use 93825 thrust washer.

CARBURETORS

**WALBRO
WT-4
A-94380-A**

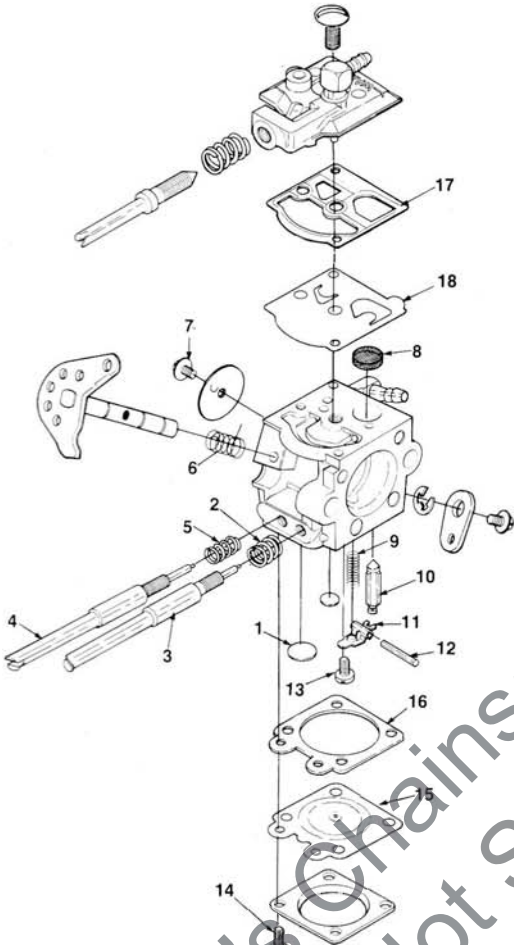

96943 Repair Kit (1-18)
96944 Gasket/Diaphragm Kit (15-18)
64229 Needle (10)

**ZAMA
C-1S-H3
A-96421**

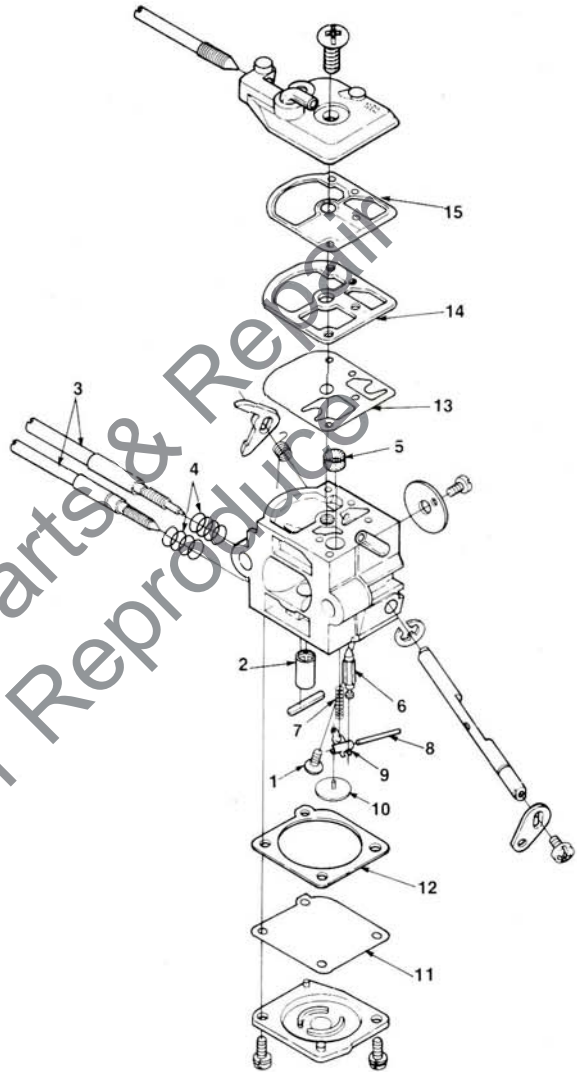

96482 Repair Kit (1-15)
96483 Diaphragm Repair Kit (11-15)

ACCESSORIES & TOOLS

GREASE- Multi use	17193
KIT- Bumper plate (330 & 330W)	A-12272-D
Includes:	
SCREW- (10-24 x 3/8)	88048
SCREW	88051
LACQUER- Touch up (red)	23475
LOCTITE	23488-B
PLUG- Bearing installation	23756
PLUG- Piston pin removal	A-23949
Includes:	
"O" RING (1)	67900
KIT- Sprocket nose repair	A-94851
Includes:	
BEARING- Guide bar	94852

SPANNER WRENCH- Clutch removal	A-24060
WRENCH- Combination	A-24284
SHIM- Black plastic (.012") rotor air gap	24306
PULLER- Rotor removal	A-24544
SEALANT	24823
CORD- Starter (250 ft. reel)	68848
SAFE•T•TIP (standard with unit)	A-70790-A
Includes:	
SCREW	82335
TUBING- Rubber (10 ft.)	93112-99
TUBING- Rubber (10 ft.)	93157-99

330 WINTER UNITS

DESCRIPTION	PART NO.	QTY.
RESTRICTER- Air (seal)- small	95846	1
RESTRICTER- Air (seal)- large	95845	1
FITTING- Tube (straight)	94619	3
COVER- Cylinder (fuel heater)	96220	1
GASKET- (Fuel heater)	96221	1
SCREW- (Fuel heater)	95922	4
TUBING- Rubber (10-3/4")		
Carburetor to cylinder	93157-43	1
TUBING- Rubber (7 1/2")		
Cylinder to valve	93157-30	1
TUBING- Rubber "TEE" to valve 2 3/4"	93112-11	1
TUBING- Rubber "TEE" to carburetor	93112-10	1
"TEE" Fitting	96840	1
PLATE- Bottom (carburetor chamber)	A-96087	1
SPACER- Carburetor (head dam)	96061	1
SHIELD- Carburetor (top plate)	96062-1	1
CARBURETOR- ZAMA	A-96421-1	1
KIT- Repair	96482	1
KIT- Diaphragm repair	96483	1
FILTER- Air	95811	1
VALVE- (Fuel line)	A-96827	1
Includes:		
"O" RING	59074	1
TUBING- Fitting	70204	1
VALVE- Check	96217	1
TUBE- Fitting	96219	1
TOGGLE SWITCH	96571	1
SPROCKET & DRUM (.325P. 8T)	A-97175	1

HOMELITE DIVISION OF TEXTRON INC.

P.O. BOX 7047
 14401 CAROWINDS BOULEVARD
 CHARLOTTE, N.C. 28217

33811BNZ

HOMELITE TEXTRON

Homelite Division of Textron Inc.