

150

**UT10432 UT10432-A UT10432-B
UT10439**

150E

UT10452 UT10452-A UT10452-B

150W

UT10513 UT10513-A UT10513-B

Leo's Chainsaw Parts & Repair
Do Not Sell or Reproduce

150 SERIES

FIGURE 1

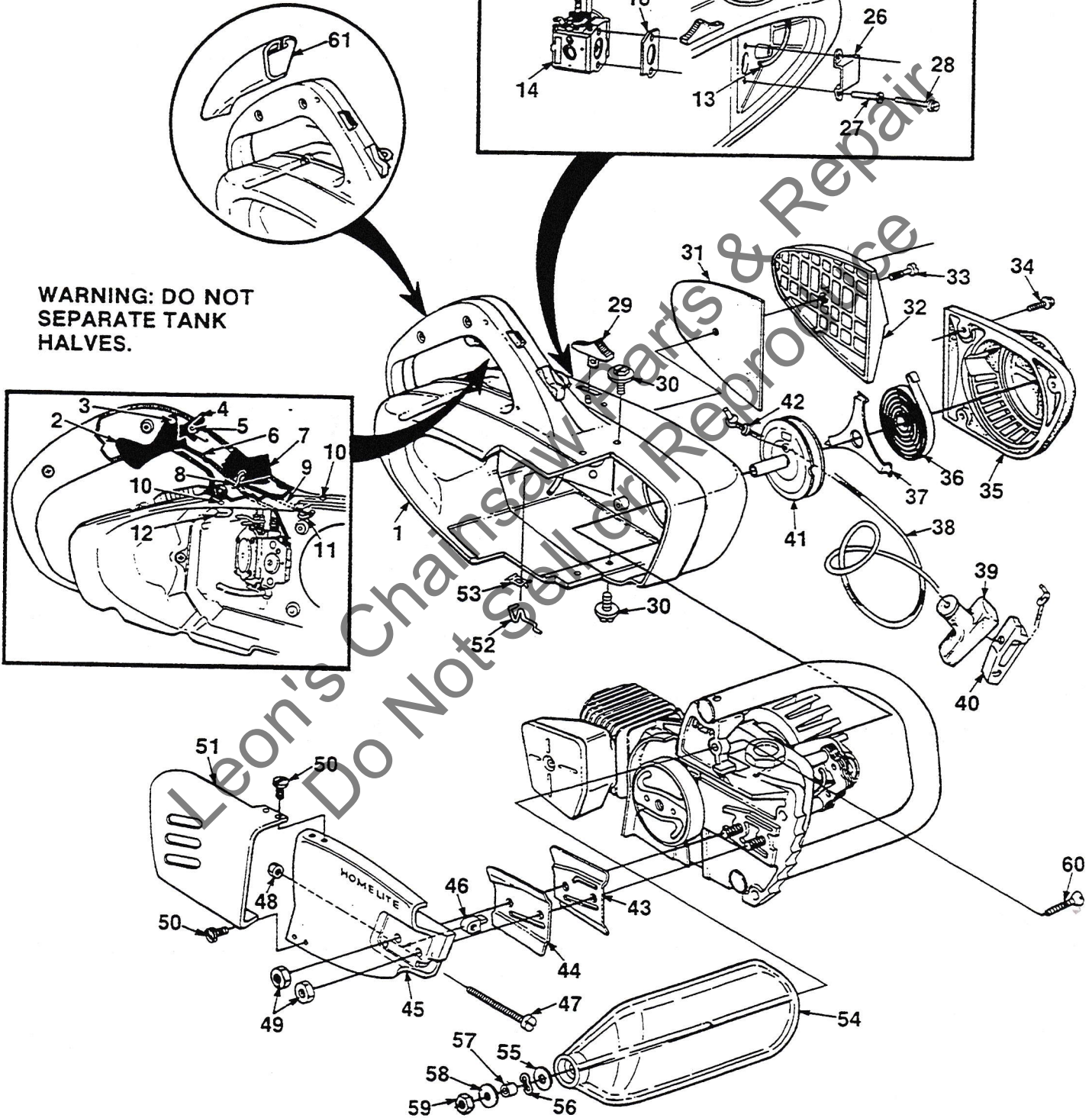

WARNING: DO NOT SEPARATE TANK HALVES.

150 SERIES FIGURE 1

No.	Description	Part No.	Qty.	No.	Description	Part No.	Qty.
1	ENGINE COVER	A-68644-1A	1	32	COVER- Air filter	68531-A	1
	ENGINECOVER (150-E)	A-69549-A	1	33	SCREW- Cover retaining	68535	1
	Includes:			34	SCREW- Hex washer hd.. 8-32 x 1/2	80983	2
2	TRIGGER- Throttle	A-93044	1		STARTER- Complete	A-68611-A	1
3	PIN- Trigger	68548	1		Includes:		
4	SPRING- Trigger latch	68626	1	35	HOUSING- Starter	A-68523-A	1
5	PIN- Grooved	68641	1	36	SPRING- Rewind	65107	1
6	LINKAGE- Throttle	68550	1	37	RETAINER- Rewind spring	68612	1
7	BUTTON- Stop switch	68580	1	38	ROPE- Starter #4 (42" long)	A-93876	1
8	SPRING- Stop switch	68581	1	39	GRIP- Starter rope	A-69962-B	1
9	LINK- Grounding switch	68576	1	40	INSERT- Rope retaining	70018-A	1
10	RIVET	85061	1	41	PULLEY- Starter	A-68645-A	1
11	CONTACT- Grounding switch	68577	1		Includes:		
12	CLAMP- High tension	68639	1	42	WASHER- Nylon	93862	1
13	TUBING- Rubber (fuel) 8"	94772-32	1	43	PLATE- Guide bar (inner)	67300-C	1
14	CARBURETOR- Walbro HDC-54	A-69957-B	1	44	PLATE- Guide bar (outer)	67299-C	1
	CARBURETOR- Till HK-30			45	COVER- Drivecase	A-68614-1A	1
	(alternate source)	A-95230-A	1		Includes:		
15	DETENT- Carburetor	A-70332	1	46	PIN- Guide bar adjusting	65112-1	1
16	SPACER- Carburetor	68537	1	47	SCREW- Guide bar adjusting	65175-A	1
17	CAP- Fuel filler	A-69500-A	1	48	NUT- Hex centerlock, 10-32	81206	1
	Includes:			49	NUT- Hex 5/16-18	81196	2
18	FILTER- Fuel cap	69454	1	50	SCREW- Pan hd.,		
19	VALVE- Check	69451	1		8-32 x 3/8 (150 AOW)	80939	2
20	GASKET- Fuel filler cap	69501	1	51	SHIELD MUFFLER- (150 AOW)		
21	CHAIN- Bead	69502	1		Included in A-94068	94071-1	1
22	RETAINER	69503	1	52	ROD- Choke	68552	1
23	SCREW- Pan hd., #6 x 1/4	82256	1	53	SPRING- Choke	68584-A	1
24	FILTER- Fuel	A-69923	1	54	HANDGUARD	A-95088	1
25	ELEMENT- Felt filter	64083	1	55	WASHER	95935	1
26	DEFLECTOR- Air	68534	1	56	WASHER	96757	1
27	BUSHING- Flanged	68560	1	57	SPACER	95937	1
28	SCREW- Hex washer hd., 8-32 x 2	82224	2	58	WASHER	84065-1	1
29	BUTTON- Choke	68551	1	59	NUT- Hex (12-24)	81225	1
30	SCREW- Sems hex hd., 10-24 x 5/8	69335-A	4	60	SCREW- Flat head	80945	1
31	FILTER- Element air	68532	1	61	COVER- Right hand (150-E)	69303	1

150 SERIES FIGURE 2

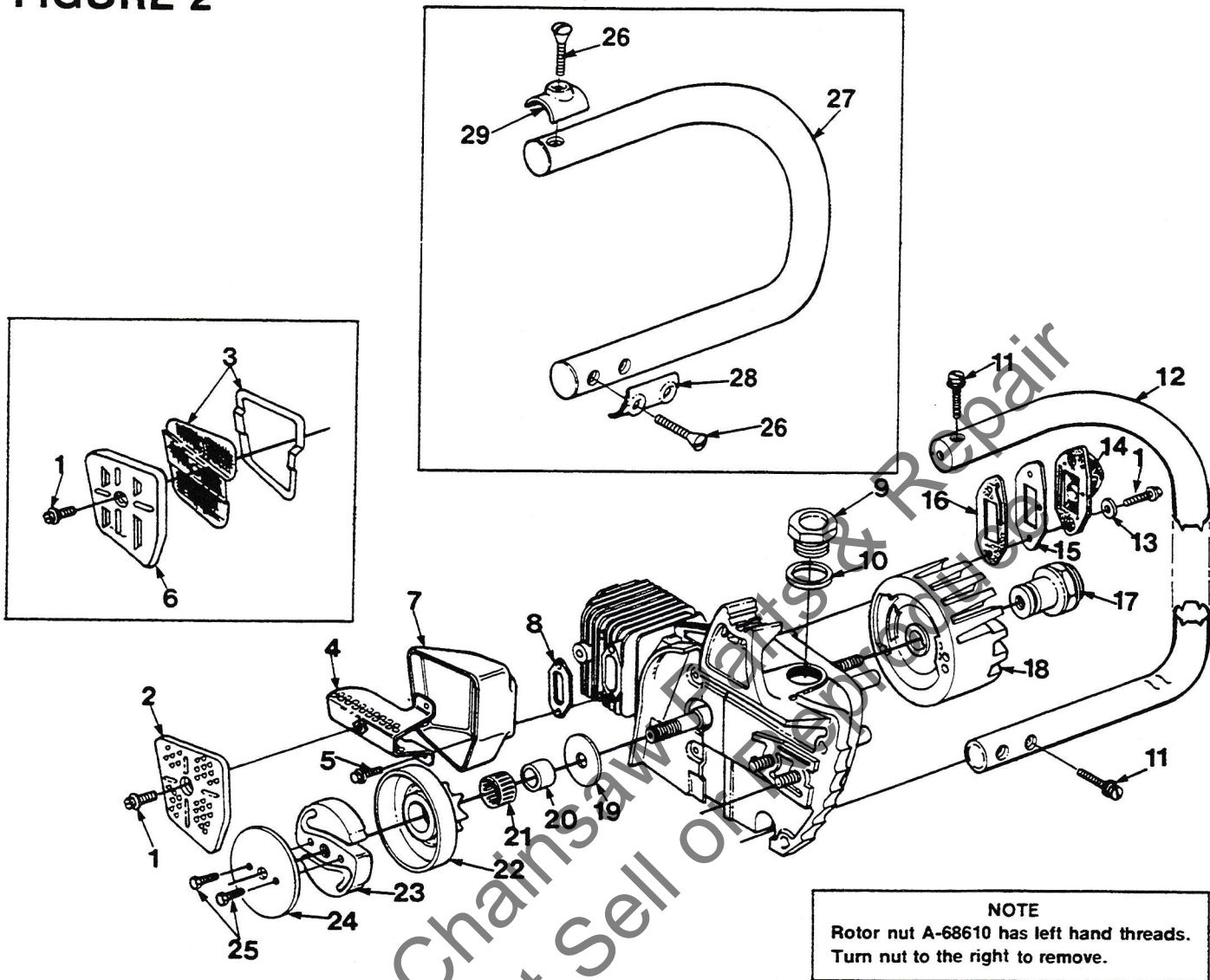

NOTE
Rotor nut A-68610 has left hand threads.
Turn nut to the right to remove.

No.	Description	Part No.	Qty.	No.	Description	Part No.	Qty.
1	SCREW- Hex washer hd., 8-32 x 1/2	80983	3	16	GASKET- Intake manifold	68464	1
2	CAP- Muffler (150 AO)	68596-1	1	17	NUT- Rotor (see note)	A-68610	1
3	ARRESTOR- Spark (150 AOW)	A-68666-1B	1	18	ROTOR (point ignition)		
4	BAFFLE- Muffler	A-68564	1		(prior to Lot #D005)	68530	1
	KIT- Muffler temp. (150 AOW)	A-94068	1		ROTOR (Solid state)		
	Includes:				(After Lot #D005)	96891	1
	#3 Arrestor	A-68666-1B	1	19	WASHER- Thrust	65064	1
5	SCREW- Hex washer hd., 8-32 x 3/8	80939	4	20	RACE- Inner	65746-B	1
	#51 SHIELD- Muffler			21	BEARING- Needle	64124	1
	(150 AOW) (Fig. 1)	94071-1	1	22	SPROCKET & DRUM- 7 tooth,		
6	CAP- Muffler (150 AOW)	94070	1		3/8" pitch	A-95619	1
7	BODY- Muffler	68545-1	1		CLUTCH & PLATE	A-69953-A	1
8	GASKET- Muffler	68542	1		Includes:		
9	CAP- Oil filler	A-68557	1	23	CLUTCH "S"	68362-7	1
	Includes:			24	PLATE- Clutch	69915	1
10	GASKET- Oil filler cap	68533	1	25	SCREW- Hex hd.,		
11	SCREW- Oval hd., 10-24 x 1 1/8	82218	3		10-32 x 1/2	80361-2	2
12	HANDLE BAR	A-70904-1	1	26	SCREW- 10-24 x 1 5/8		
13	WASHER- Flat				(150 E)	82378	2
14	MANIFOLD- Intake	A-68520-2	1	27	HANDLE BAR (150 E)	A-95291	1
15	COVER- Pulse	68671	1	28	CLAMP- Handle bar (lower)	69301	1
				29	CLAMP- Handle bar (upper)	69302	1

PRIOR TO LOT #D005

150 SERIES FIGURE 3

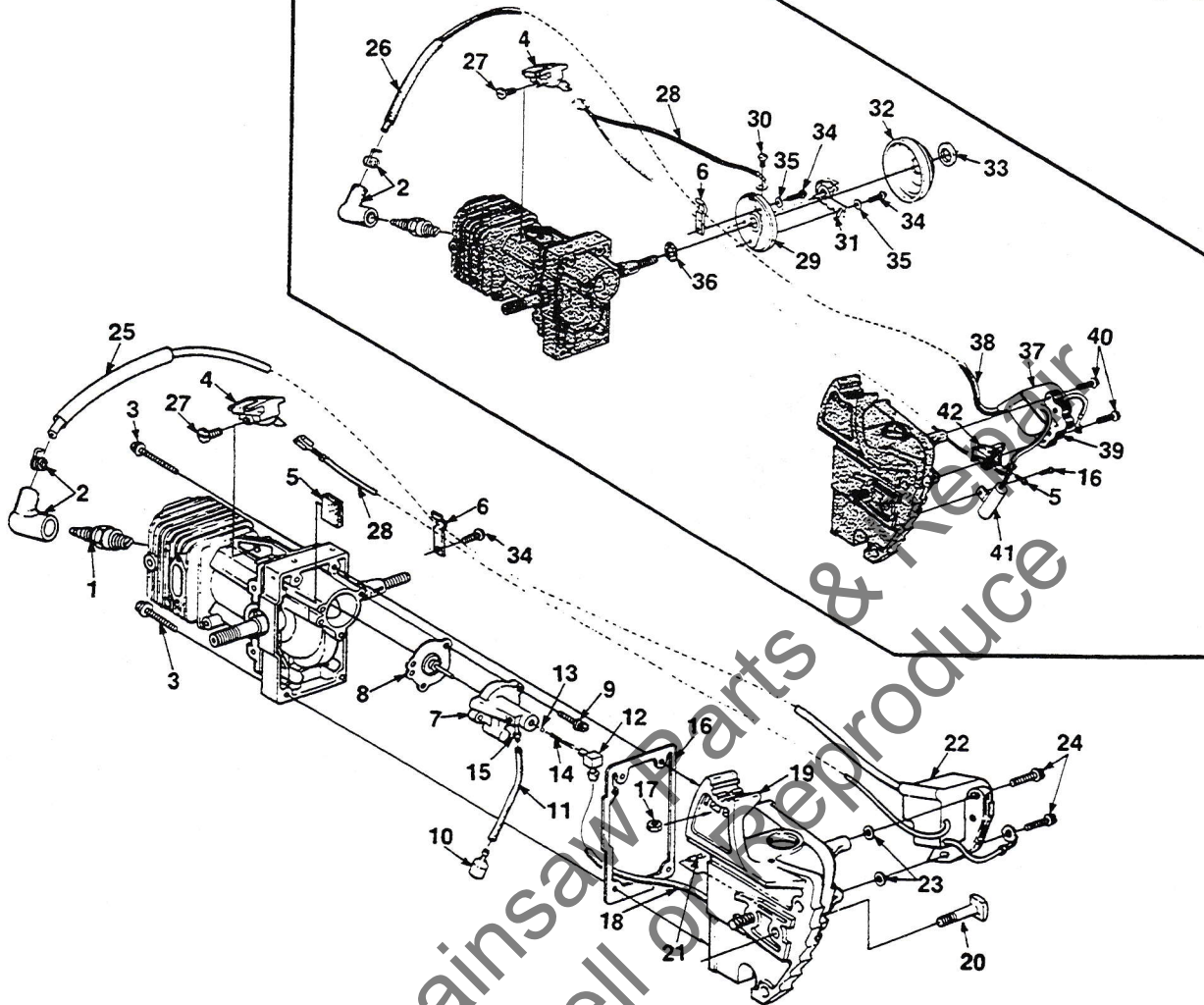

No.	Description	Part No.	Qty	No.	Description	Part No.	Qty.
1	SPARK PLUG	68616-S	1	24	SCREW- Mach	82248	2
2	TERMINAL- Spark plug	A-33055	1	25	SLEEVE- Insulating	96907	1
3	SCREW- Hex washer hd. 8-32 x 1.25	88045	4	26	SLEEVE- Wire (fiberglass)	68625	1
4	BUSHING & TERMINAL	A-69341	1	27	SCREW- Pan hd., plastite (6 x 1/4)	82256	2
5	COVER- Vent	68990-A	1	28	LEAD- Stop switch	A-93626	1
6	CLAMP- High tension lead	68623	1	29	BOX- Breaker	A-69533-A	1
7	PUMP- Automatic oil	A-70974-A	1		Includes:		
	Includes:			30	SCREW- Plastite #6 x 1/4	82256	1
8	PLUNGER- Oil pump	A-68583-B	1	31	POINTS- Breaker	A-94631	1
9	SCREW- 8-32 x .625	82291	2	32	COVER- Breaker box	A-94231	1
10	FILTER- Oil	A-68593	1		Includes:		
11	LINE- Oil pick-up 2 1/4"	70309-09	1	33	SEAL- Breaker box cover	68618-A	1
12	FITTING- Tube	70204	1	34	SCREW- Pan washer hd., 6-32 x 3/8	80571	2
13	BALL- Check friction	60051	1	35	WASHER- Flat #8	84025	2
14	SPRING- Choke valve	68570	1	36	SEAL	93849	1
15	FITTING- Tube	94619	1	37	COIL- Ignition	A-68649-A	1
16	GASKET- Oil tank	68589-C	1		Includes:		
17	NUT- Hex centerlock 10-24	81208	1	38	LEAD- Hi- tension	68629	1
18	RUBBER- Tubing 4 3/4	93112-19	1	39	CORE	A-68648	1
19	TANK- Oil	A-93743-1A	1		Includes:		
	Includes:				RETAINER- Coil (not shown)	68257	1
20	BOLT- Guide bar	58753	2	40	SCREW- Hex hd., 8-32 x 3/4	82248	2
21	FITTING- Tube	70972	1	41	CONDENSER	68543	1
22	KIT- Ignition conversion	A-97026	1	42	BLOCK- Terminal	68613	1
	Includes:						
23	WASHER- Flat	84101	2				

ALWAYS FURNISH MODEL AND SERIAL NUMBER WHEN ORDERING PARTS.

150 SERIES

FIGURE 4

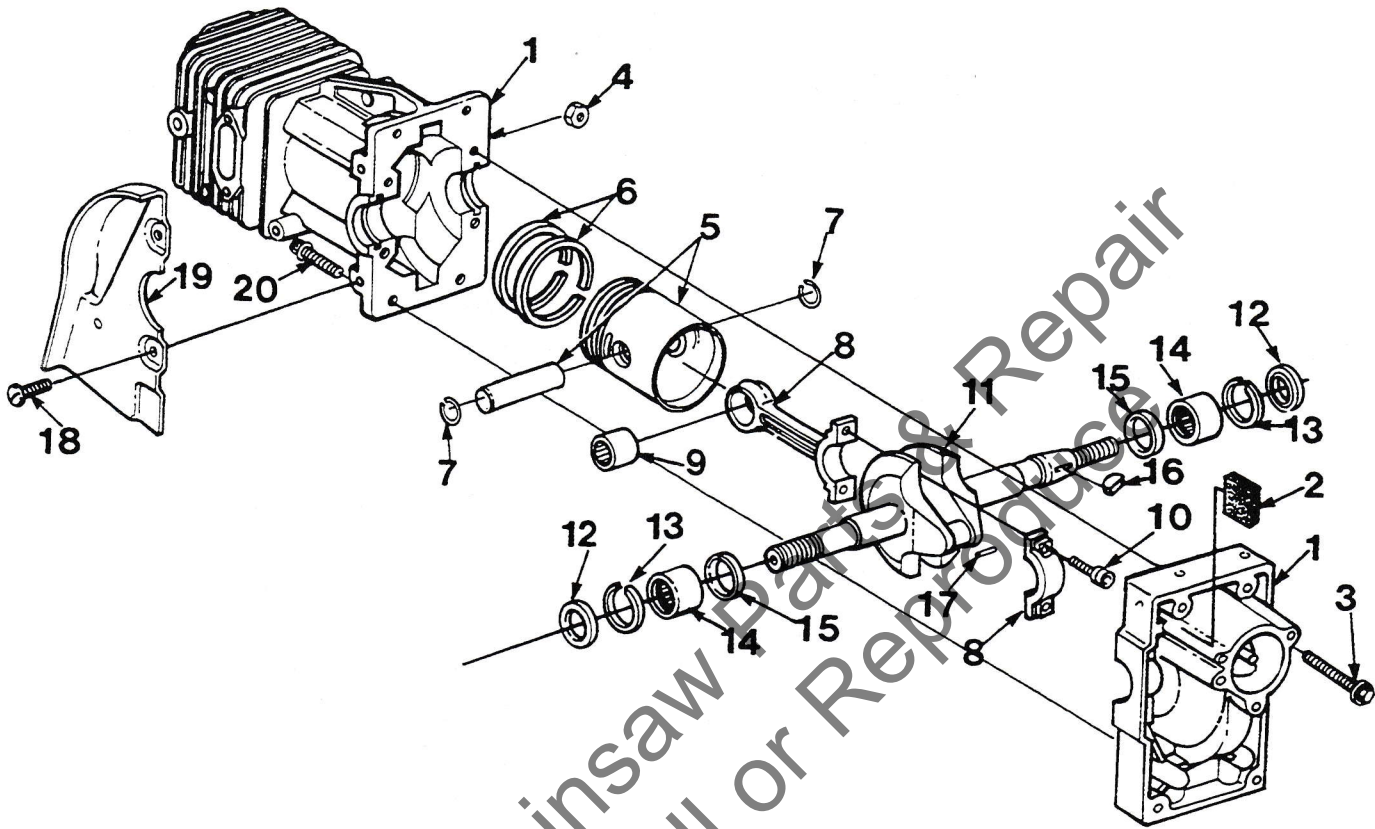

No.	Description	Part No.	Qty.	No.	Description	Part No.	Qty.
1	CRANKCASE & CYLINDER Includes:	A-68643-D	1	8	ROD- Connecting Includes:	A-68518	1
2	COVER- Vent	68990-A	1	9	BEARING- Needle	68512	1
3	SCREW- Hex washer hd. 8-32 x 1	88044	4	10	SCREW- Soc. hd.. 8-32 x 1/2	69919	2
4	NUT- Hex centerlock 8-32 CLAMP- (not shown)	81223	4	11	CRANKSHAFT	68507-1	1
	PIN- Dowel (not shown)	64309-1	1	12	SEAL	94638	2
	SCREW- Pan washer hd. 6-32 x 3/8 (not shown)	80571	2	13	RING- Retaining	68514	2
5	PISTON & PIN	A-68642	1	14	BEARING- Roller	12530	2
	Includes:			15	BEARING- Thrust	68509-A	2
6	PISTON- Ring	68508	2	16	KEY- Woodruff	65126	1
7	RING- Piston retaining	64813	2	17	ROLLER- Needle (set of 18)	A-68511	1
				18	SCREW- Pan tapite 8-32 x 5/16	95922	3
				19	SHIELD- Sawdust	68596	1
				20	SCREW- Hex hd. 8-32 x 3/4	82248	4

**(Primary)
CARBURETOR
HDC-54
A-69957-B**

**(Alternate)
CARBURETOR
HK-3D
A-95230-A**

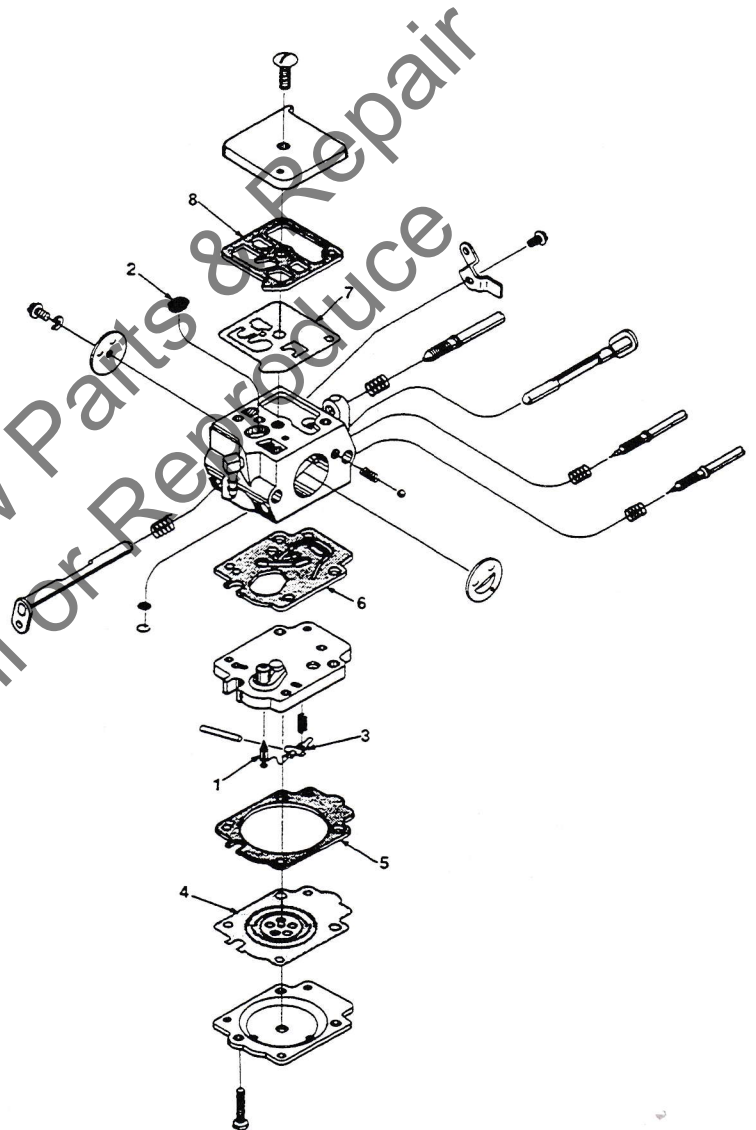
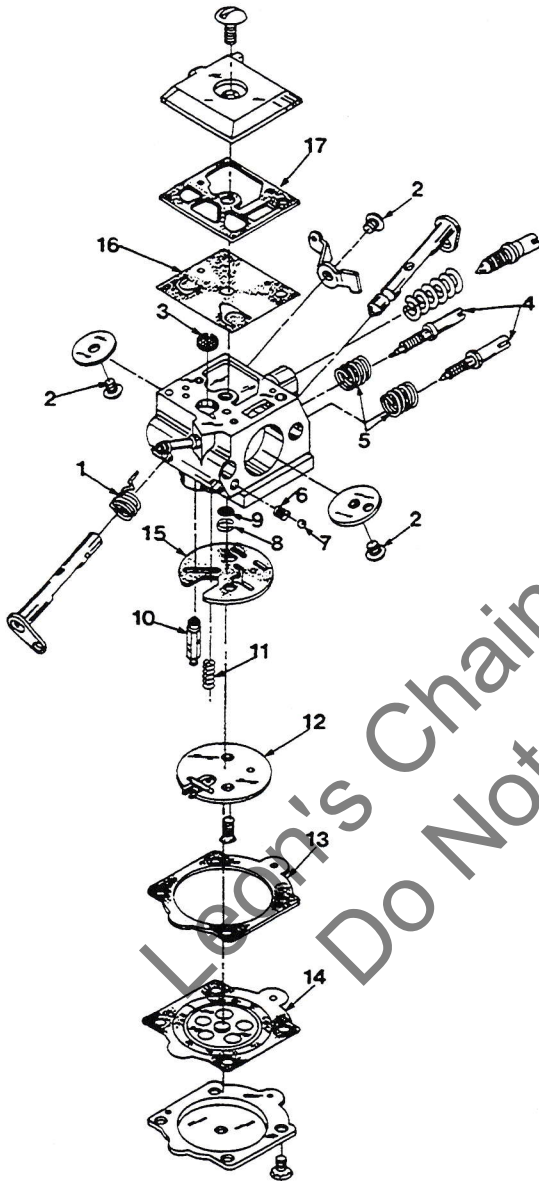

REPAIR KIT (includes #1-17)
GASKET- Diaphragm Kit
 Includes #13-17)
REPAIR KIT- Check valve

93200-B
94701
65386

REPAIR KIT (1-8)
GASKET- Diaphragm Kit (4-8)
NEEDLE- Inlet

95697
70094
70109

ACCESSORIES

GREASE	17193
KIT- Spike bumper	A-68655
Includes:	
SCREW (2)	80648
NUT (2)	81206
REEL- 250 Ft. starter rope #4	68848
TUBING- Rubber 10 ft.	70309-99
TUBING- Rubber 10 ft.	94772-99
TUBING- Rubber 10 ft.	93112-99
PAINT- Red- 12oz.	23475
CASE- Carrying	94216
DECALS- Set of four	A-69048-A

TOOLS

TOOL- Check valve	24972
GAUGE- (.015 pink plastic feeler)	22486
LOCTITE	23488-C
PLUG- Needle bearing installation	23756
PULLER- Magneto rotor	A-24544
Includes:	
SCREW- Hex 10-32 x 1 3/8 (4)	82162
WASHER- Flat #10 (4)	84003-1
NUT- Hex centerlock 10-32 (4)	81206
SCREWDRIVER	24541
SHIM (.012 black plastic) Magneto air gap	24306
SPACER- Plug	24548
WRENCH- Spanner (clutch)	A-93791
Includes:	
PIN- Clutch spanner (2)	23717-A
WRENCH- Socket	68651

HOMELITE DIVISION OF TEXTRON INC.

P.O. Box 7047
14401 Carowinds Boulevard
Charlotte, N.C. 28217

Overseas Office

Homelite Division of Textron
Korenaarstraat 1
2153 BM Nieuw Vennepe
The Netherlands

Homelite Division of Textron
Pacific Limited
P.O. Box 209
Blackburn, 3130
Victoria, Australia

HOMELITE TEXTRON

Homelite Division of Textron Inc.

1384BNZ